

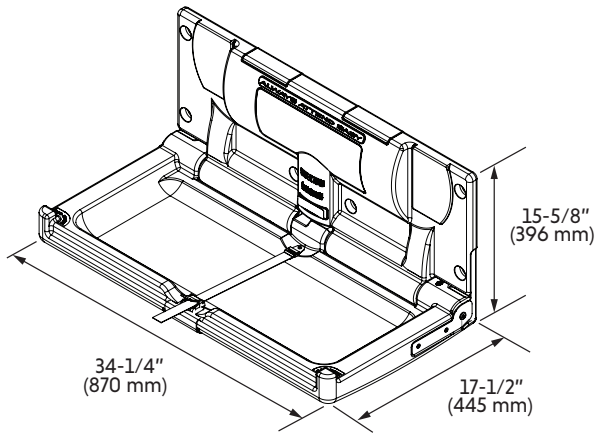

# Submittal Sheet

## Model: 10HS020X Origin Horizontal Diaper Changing Station with EZMount™ Backer Plate



### Recommended Blocking

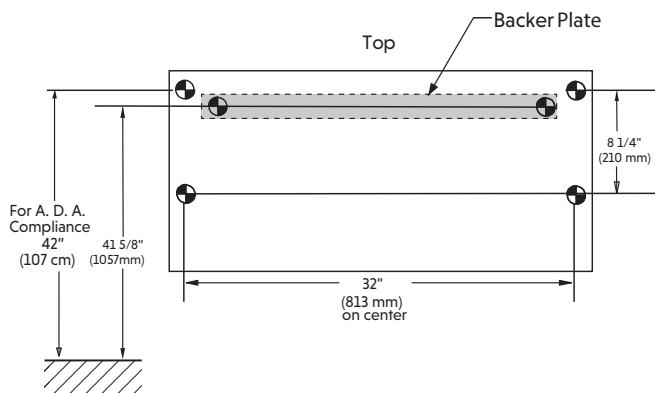

### Short Specifications

Polyethylene Diaper Changing Stations:

1. Acceptable product: The Sova Company™; Model: Origin (10HS020X).
2. Characteristics:
  - a. Type: Molded FDA approved high-density polyethylene (HDPE) body.
  - b. EZ Mount™ Backer Plate eliminates need for structural backing.
  - c. Smooth nylon belt with Thermoplastic Polyurethane coating. Easy to sanitize and adjustable with one hand.
  - d. Warning labels printed in English, Spanish and French.
  - e. Meets ASTM F2285 requirements for weight bearing Commercial Changing Stations.
3. A.D.A. Compliance:
 

306.3	Knee Clearance
307.2	Maximum Protruding Objects
308.2	Forward Reach
308.3	Side Reach
309.4	Operation
902.3	Work Surface

Compliant when properly installed.
4. ANSI compliant safety labels.
5. CPSIA compliant to applicable sections.



- Exclusive EZ Mount™ Backer Plate reduces installation time and enables unit to be attached to wall with only one installer. Also facilitates difficult and retrofit installations by eliminating the need for structural blocking and ensuring connection with two studs.
- Easy to clean, high-density polyethylene which is naturally bacteria resistant.
- Standard with molded-in dual liner dispensers.
- Each liner dispenser holds approximately 50 of the 05XX0107 or 05XX0207 liners.
- Smooth nylon belt with Thermoplastic Polyurethane coating. Easy to sanitize and adjustable with one hand.
- Convenient bag hooks clearly labeled on both sides.
- Easy to read ANSI compliant labels (ANSI Z535.3 and ANSI Z535.4), utilizing universal safety symbols.
- Compact, slim profile meets A.D.A when properly installed. Only protrudes 4 inches or 102 mm from wall.
- Includes universal baby changing station door sign.
- Pneumatic gas shock mechanism to ensure smooth, safe open and close motions.
- Steel-to-steel support hinges.
- Includes easy to install, step-by-step instructions plus all mounting hardware.
- ASTM G21 Anti-Bacterial: No measurable bacterial growth.
- Meets or exceeds ASTM F2285 Safety Specifications for Commercial Changing Stations.
- Standard pack: 1 unit.
- Limited Warranty: This product is warranted against manufacturing defects for a period of 5 years.

### Installation Information

- Closed unit projects 4 inches (101 mm) from wall.
- Open changing surface projects 17-1/2 inches (445 mm) from wall during use.
- Overall closed dimensions are 34-1/4 inches (870 mm) wide and 15-5/8 inches (396 mm) tall.
- Hardware allows for mounting to current or new construction applications.