

Wooden Ladder Back Barstool

ASSEMBLY INSTRUCTIONS



LANCASTER™
TABLE & SEATING

PARTS LIST:

A Frame 1/PC

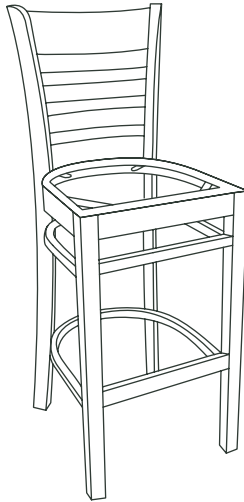

B Seat

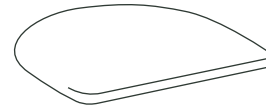

C Long Screws 2/PC

D Short Screws 2/PC

REQUIRED TOOLS: • Screwdriver

NOTES:

1. Inspect all pieces for damage before assembly. Do not assemble if any pieces are broken or damaged. Ensure you have all required pieces before assembly.
2. Power drill is optional for assembly.
3. There are two options for assembly, please reference both steps for your preference.

STEP 1

Option 1: Place chair frame (A) on its back. Center seat (B) on the frame with four screw holes, push cushion against frame, ensuring front of seat is parallel with the front of the frame.

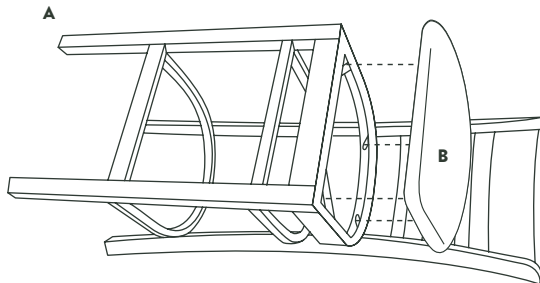

OR

Option 2: Place seat (B) upside down on flat surface, preferably a table. Align chair frame (A) on top of seat (B). Center seat with four screws holes on frame, push seat against the back of the frame and ensure seat is parallel to the front of the frame.

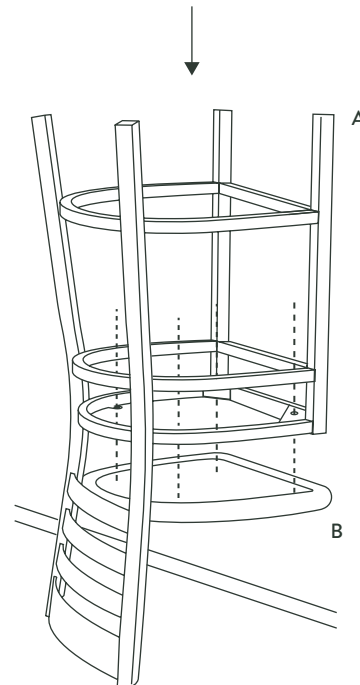

Wooden Ladder Back Barstool

ASSEMBLY INSTRUCTIONS



LANCASTER™
TABLE & SEATING

STEP 2

Attach seat (B) to frame (A) with four screws using a screwdriver or power drill. Secure long screws (C) in the wooden screw hole slots at the front of the chair frame. Secure short screws (D) in the metal brackets towards the back of the chair frame.

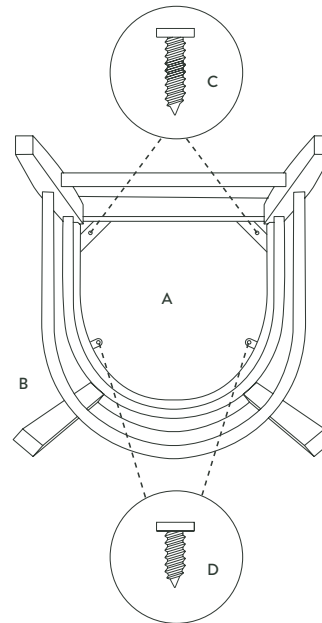

STEP 3

Ensure all screws are tightened fully.
Stand chair upright for usage.

