

# User Manual



## Countertop Electric Fryers



351EF300, 351EF302



REVISED 08/2023

## IMPORTANT FOR FUTURE REFERENCE:

Please complete this information and retain this manual for the life of the equipment. For Warranty Service and/or other parts, this information is required.

\_\_\_\_\_

Model Number	Serial Number	Date Purchased
--------------	---------------	----------------

### WARNING:

For your safety, do not store or use gasoline or other flammable vapors or liquids in the vicinity of this or any appliances. Keep the area free and clear of combustible materials. (See ANSI Z83. 14B, 1991.)

### WARNING:

Improper installation, adjustment, alteration, service, or maintenance can cause property damage, injury, or death. Read the installation, operating, and maintenance instructions thoroughly before installing or servicing this equipment.

### CAUTION:

These models are designed, built, and sold for commercial use only. If these models are positioned so the general public can use the equipment, make sure that cautions, warnings, and operating instructions are clearly posted near each unit so that anyone using the equipment will use it correctly and not injure themselves or harm the equipment.

### WARNING:

A factory authorized agent should handle all maintenance and repair. Before doing any maintenance or repair, contact your authorized service representative

### WARNING:

An earthing cable must connect the appliance to all other units in the complete installation and from there to an independent earth connection.

### NOTICE:

When installed the unit must be electrically grounded and comply with local codes, or in the absence of local codes, with the national electrical code ANSI/NFPA70- latest edition. Canadian installation must comply with CSA-STANDARD C.22.2 Number 0 M1 982 General Requirements-Canadian Electrical Code Part II, 109-M1981- Commercial Cooking Appliances.

### WARNING:

**SHOCK HAZARD** - De-energize all power to equipment before cleaning the equipment.



Congratulations on your purchase of Cooking Performance Group commercial cooking equipment! At Cooking Performance Group, we take pride in the design, innovation, and quality of our products. To ensure optimal performance, we have outlined the following instructions and guidelines in this manual carefully for your review. Cooking Performance Group declines any responsibility in the event users do not follow the instructions or guidelines stated here.

## Contents

Serial Plate . . . . .	3
Safety Precautions . . . . .	4
Installation Instructions . . . . .	4
Operating Instructions . . . . .	5
Cleaning . . . . .	5
Technical Specifications . . . . .	6
Troubleshooting . . . . .	7
Parts List . . . . .	8
Basket Assembly . . . . .	8
Parts Diagram . . . . .	9

## Serial Plate

The serial plate is located on the side panel.

**IMMEDIATELY INSPECT FOR SHIPPING DAMAGE.**

All equipment should be examined for damage before and during unloading. The freight carrier has assumed responsibility for its safe transit and delivery. If equipment is received damaged, either apparent or concealed, a claim must be made with the delivering carrier.

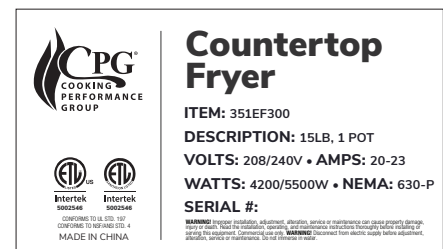

- A) Apparent damage or loss must be noted on the freight bill at the time of delivery. It must then be signed by the carrier representative (Driver). If this is not done, the carrier may refuse the claim. The carrier can supply the necessary forms.
  
- B) If concealed damage is not apparent until after equipment is uncrated, a request for inspection must be made to the carrier within 5 days. The carrier should arrange an inspection. Be certain to hold all contents and packaging material.

## Safety Precautions

### **DANGER:**

This symbol warns of imminent hazard which will result in serious injury or death.

### **WARNING:**

This symbol refers to a potential hazard or unsafe practice, which could result in serious injury or death.

### **CAUTION:**

This symbol refers to a potential hazard or unsafe practice, which could result in minor or moderate injury or product or property damage.

### **NOTICE:**

This symbol refers to information that needs special attention or must be fully understood, even though it is not dangerous.

### **NOTICE:**

This product is intended for commercial use only. Not for household use.

### **NOTICE:**

Local codes regarding installation vary greatly from one area to another. The National Fire Protection Association, Inc., states in its NFPA96 latest edition that local codes are “Authority Having Jurisdiction” when it comes to requirements for installation of equipment. Therefore, installation should comply with all local codes.

## Installation Instructions

Installation and service should be performed by a qualified installer who thoroughly reads, understands, and follows these instructions.

If you have questions concerning the installation, operation, maintenance, or service of this product, visit Cooking Performance Group’s website at [www.CookingPerformanceGroup.com](http://www.CookingPerformanceGroup.com).

1. Always clean equipment thoroughly before first use.
2. Check rating label for your model designation & electrical rating. Consult with your electrician before using any electrical equipment. Failure to do so will void the warranty.
3. For best results, use stainless steel countertops that are even and free of debris/liquids.
4. Attach the four legs to the bottom of the unit and place the fryer on the countertop. Use a level to ensure the adjustable feet are all even.

## Operating Instructions

1. All food service equipment should be operated by trained personnel. Improper use of fryers can result in serious injury or death, since temperatures reach in excess of 350°F.
2. Do not allow your customers to come into contact with any part of the fryer.
3. Before operating, check to ensure your power supply is correct to match the data plate.
4. Once the fryer is installed on a level surface and connected to a power source, add oil to the oil pan. DO NOT fill above the max fill line. It is recommended to start at the MIN line and then add more if needed to prevent any chances of overfill.
5. With the oil in the pan, turn the fryer on and move temperature knob to desired temperature.
6. Allow the Fryer 15-30 min to reach desired temp.
7. Do not overload the basket with product.
8. Drop the basket in slowly and fry for desired time.
9. If using tongs to separate product, you must also wear high heat gloves to prevent burns.
10. Once product is done, lift the basket and use the side mounted hanger to drain the additional grease off the product.

## Cleaning

1. Always turn unit off, unplug, and allow to cool completely before cleaning.
2. Never clean unit by immersing it in water.
3. Tilt the fryer head back which lifts the element. Remove the oil pan and safely drain the oil using the side handles on the pan. Oil should be drained nightly at a minimum and more depending on frequency of use.
4. Replace the pan and move the heating head/element back into operating position.
5. Add water to the "MAX" Line.
6. Add Noble Chemical Fryclone Cleaner or other food grade cleaner and follow cleaner instructions.
7. Turn the thermostat to 250°F. Let the heating unit bring the solution to a boil.
8. Boil long enough to loosen or dissolve all varnish or carbon deposits. This should take approximately 30 minutes.
9. Turn the unit off.
10. Rinse with clean water to remove all cleaning mixture.
11. Rinse the inside of the tank with 2 cups of vinegar.
12. Rinse with clean water until the vinegar odor is gone. The fry tank must be thoroughly rinsed since even a trace of cleaner left inside the tank will contaminate the fry compound.
13. Dry thoroughly.
14. Cover the tank if compound will not be added until a future date.
15. Clean all exterior surfaces of unit on a regular basis with a damp cloth.
16. To remove discolorations or oil film, use a non-abrasive cleaner such as Noble Chemical QuikSan.

## Technical Specifications

Name	15LB Deep Fryer	30LB Deep Fryer
Model	EF300	EF302
Voltage	208/240V	208/240V
Power	5200/5500W	8,400/11,000W
Plug	Nema 6-30P	2x Nema 6-30P
Number of Oil Tanks	1	2
Size of Oil Tanks	14" x 12" x 9"	14" x 12" x 9"
Number of Frying Baskets	1	2
Size of Frying Baskets	11¼" x 9¾" x 5½"	11¼" x 9¾" x 5½"
Cooking Temperature Range	120°F - 375°F	120°F - 375°F
Temperature Safety Cut-Off	446°F	446°F
Overall Dimensions	13¼" x 21½" x 14"	27" x 21½" x 14"

## Troubleshooting Guide

PROBLEM	PROBLEM CAUSE							
	Frying Temperature Too High/Overheating (Check Thermostat)	Frying Temperature Too Low/Underheating (Check Thermostat)	Overloading Fryer	Improper Draining of Food After Frying	High Moisture Content in Food Being Fried	Inadequate Frying Compound Turnover	Improper Preparation of Food	Contamination of Fryer Compound (Due to salt or other foreign material)
Excessive & Premature Foaming	●		●			●		●
Greasy Food / Excessive Frying Compound Absorption		●	●	●	●	●	●	
Objectionable Odor or Flavor of Frying Compound					●	●		●
Objectional Flavor of Fried Food				●		●	●	
Excessive Smoking of Frying Compound	●					●	●	●
Excessive Darkening of Frying Compound	●					●	●	●
Frying Compound Won't Hold Heat		●	●		●		●	
Food Crust Color Not Brown		●	●		●		●	
Rapid Breakdown of Frying Compound	●				●		●	●

## Parts List

ITEM #	PART	PART #
351PEF1	Power Cord 208/240V	1
351PEF2	Power Cord Connector	2
351PEF3	Terminal Block	3
351PEF6	Microswitch	6
351PEF7	Thermostat	7
351PEF10	Temp Limiter	10
351PEF12	Knob Control Metal	12
351PEF13	Element	13
351PEF14	Element Cover	14
351EFBASK	Basket Fryer 11" x 9.75" x 5.5"	15
351PEF16	Oil Tank Fryer	16
351PEF18	Adjustable Leg	18

## Basket Assembly

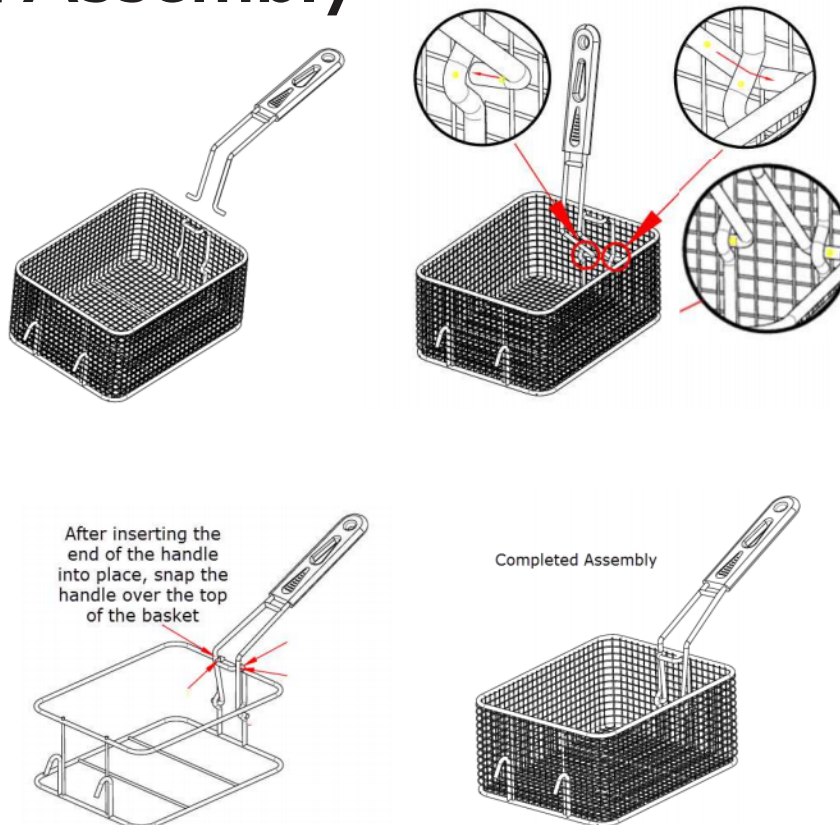



## Parts Diagram

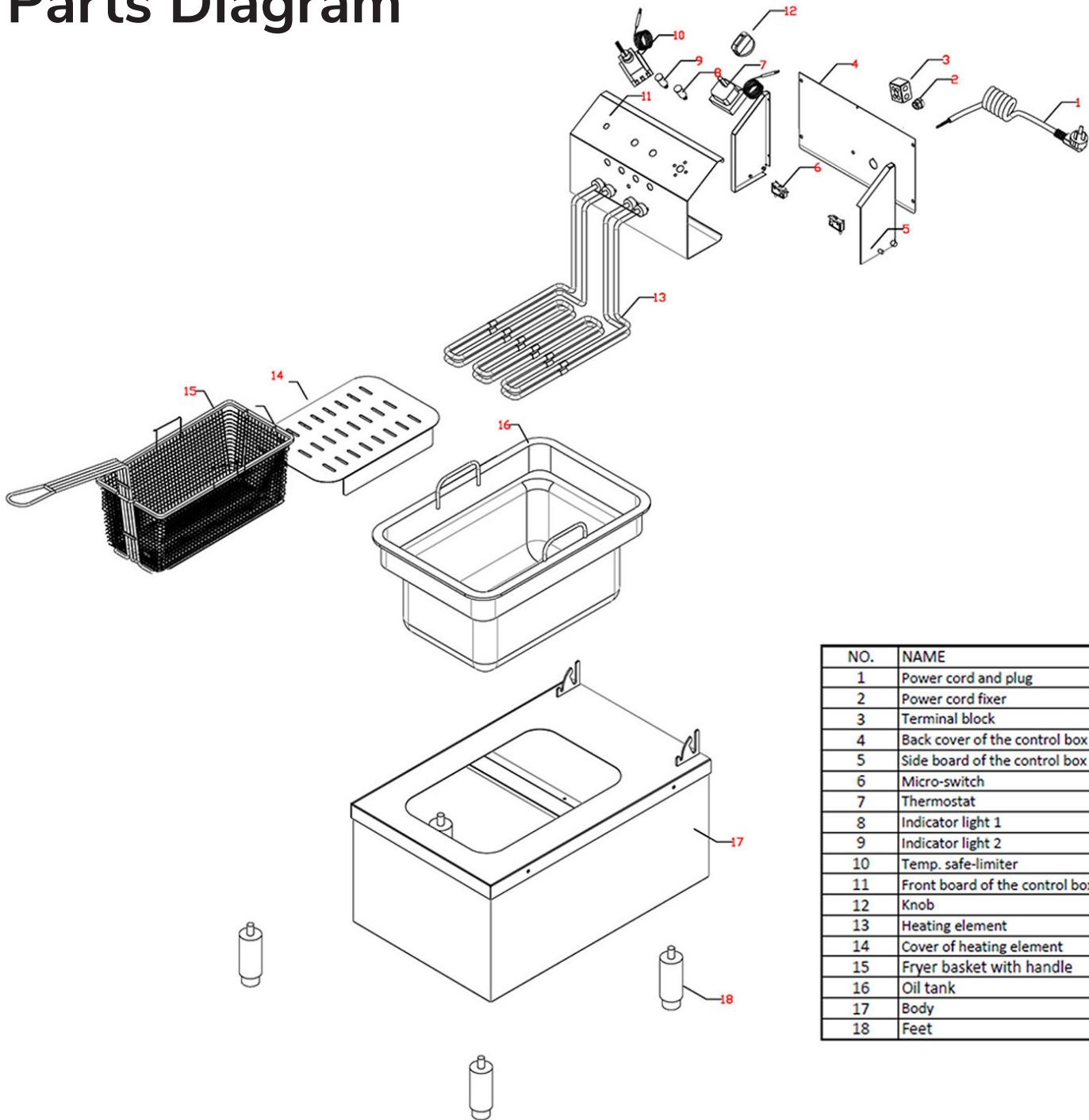

NO.	NAME
1	Power cord and plug
2	Power cord fixer
3	Terminal block
4	Back cover of the control box
5	Side board of the control box
6	Micro-switch
7	Thermostat
8	Indicator light 1
9	Indicator light 2
10	Temp. safe-limiter
11	Front board of the control box
12	Knob
13	Heating element
14	Cover of heating element
15	Fryer basket with handle
16	Oil tank
17	Body
18	Feet