

Slat Back Barstool

ASSEMBLY INSTRUCTIONS



LANCASTER
TABLE & SEATING

SPARTAN Series

PARTS LIST:

A Frame 1/PC

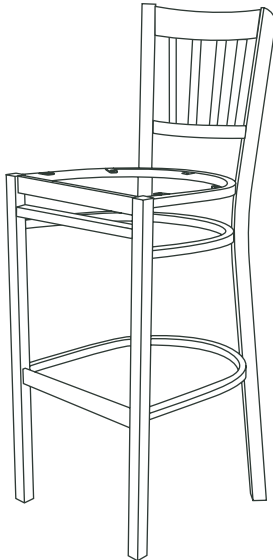

B Vinyl Cushion 1/PC

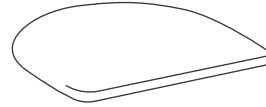

C Screws 5/PC



REQUIRED TOOLS: Screwdriver

NOTES:

1. Inspect all pieces for damage before assembly. Do not assemble if any pieces are broken or damaged. Ensure you have all required pieces before assembly.
2. Power drill is optional for assembly.
3. There are two options for assembly, please reference both steps for your preference.

STEP 1

Option 1: Place chair frame (A) on its back. Center cushion (B) on the frame with five screw holes, push the cushion against frame, ensure front of cushion is parallel to the front of the frame.

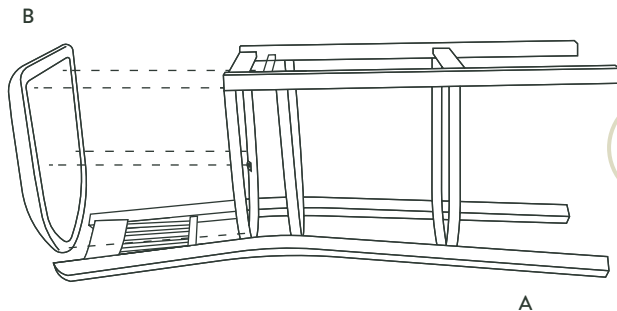

OR

Option 2: Place seat (B) upside down on a flat surface, preferably a table. Align chair frame (A) on top of cushion (B). Center cushion with five screw holes on frame, push cushion against the back of the frame and ensure front of cushion is parallel to the front of the frame.

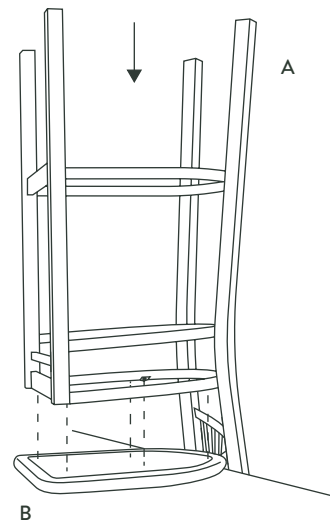

Slat Back Barstool

ASSEMBLY INSTRUCTIONS



LANCASTER™
TABLE & SEATING

SPARTAN *Series*

STEP 2

Attach cushion (B) to frame (A) with five screws (C) using a screwdriver or powerdrill.

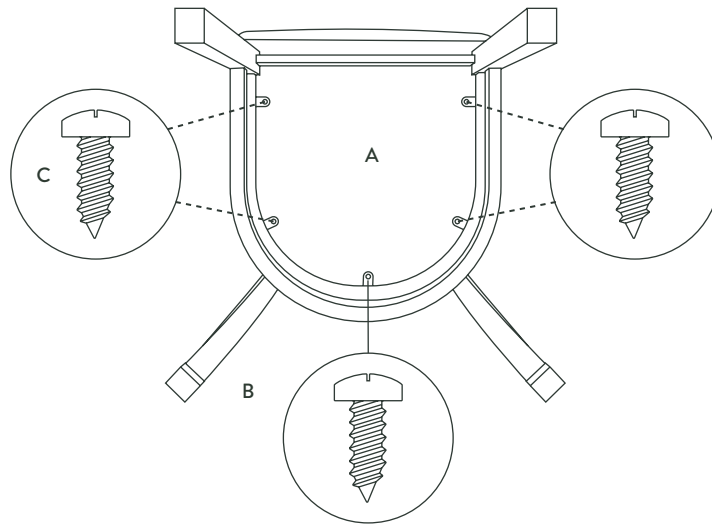

STEP 3

Ensure all screws are tightened fully.
Stand chair upright for usage.

