

## Work Table with Undershelf

### Assembly Instructions

#### TOOLS REQUIRED

Allen wrench (included)

#### 4 Leg Table

##### PARTS:

- (A) (1) Stainless Steel Top
- (B) (1) Undershelf
- (C) (4) Legs
- (D) (8) Tightening Screws

#### 6 Leg Table

##### PARTS:

- (A) (1) Stainless Steel Top
- (B) (1) Undershelf
- (C) (6) Legs
- (D) (16) Tightening Screws

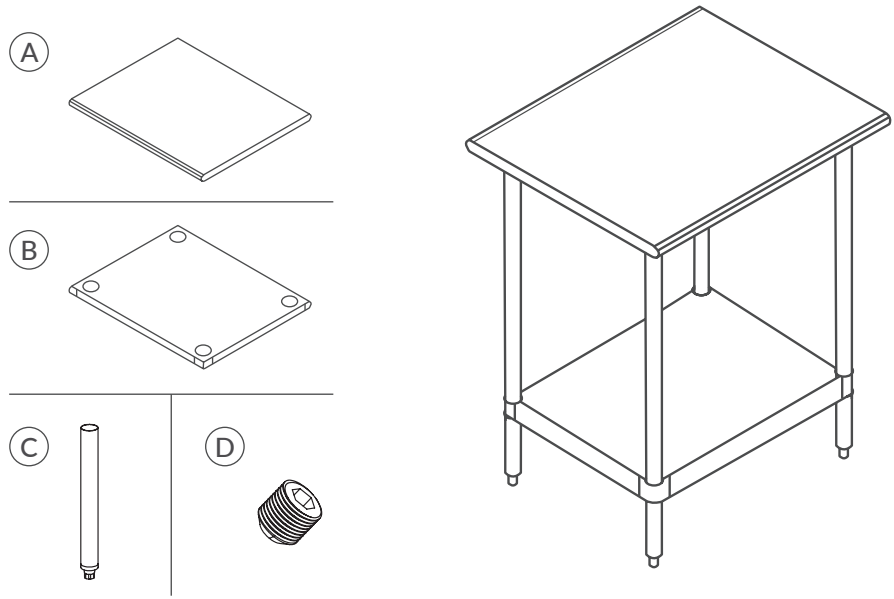

### Assembly Instructions

1. Make sure the assembly area is a clean and level surface. Carefully remove all the contents from the box. Place the table top face down on a rug, carton, or other protected surface.
2. Determine the undershelf placement by marking the desired height on the legs. Place the undershelf on its side and insert the legs through the bottom of the undershelf with the gusset end first (opposite end of the bullet feet). **NOTE:** The undershelf needs to be at least 6" off the ground to be NSF certified.
3. Tighten set screws on undershelf to attach legs. **NOTE:** Don't tighten completely until Step 4 is complete.
4. Insert the legs into the table top gussets. You may need to loosen the set screw if one leg isn't lining up exactly.
5. Once all legs are inserted into the gussets, tighten all set screws.
6. Adjust the feet as needed to meet height requirements or to compensate for uneven flooring.
7. With assistance, turn the table over and remove any protective films. The table is now ready to be used.

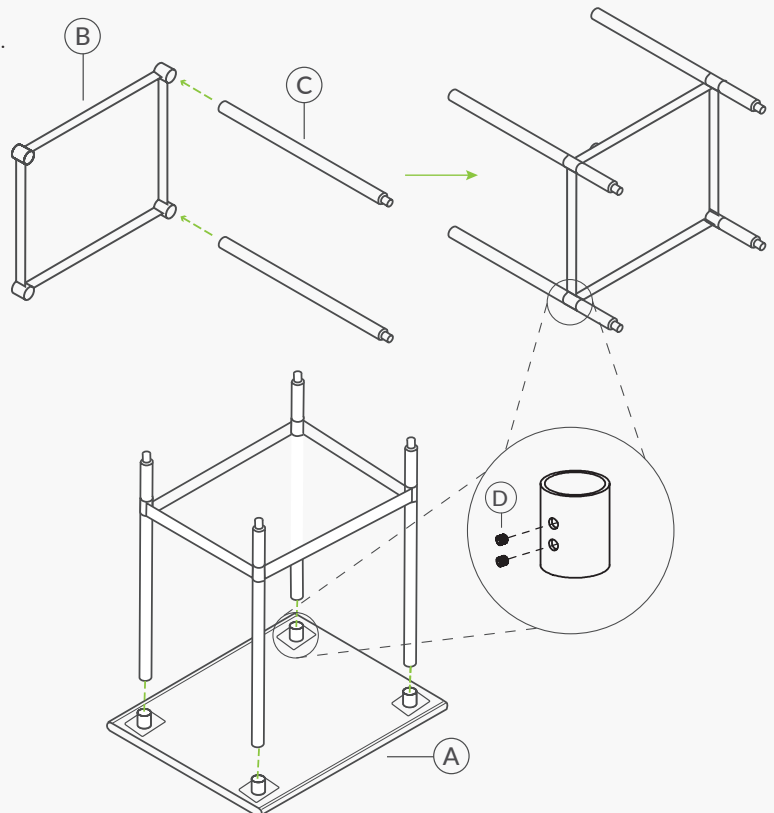

**WARNING!** Risk of personal injury. Stainless steel edges are sharp and can cause cuts. Wear gloves during installation and handle with care. The table undershelf must be installed for proper table stability.