



compactSchwank

Series P40-R

GAS-FIRED VENTED ROOM HEATER
VENTED OVERHEAD RADIANT TYPE

Compact Series

Series P40-IR

GAS-FIRED VENTED ROOM HEATER
VENTED OVERHEAD RADIANT TYPE

INSTALLATION / OWNER'S MANUAL



WARNING: If the information in these instructions is not followed exactly, a fire or explosion may result causing property damage, personal injury or loss of life.

- Do not store or use gasoline or other flammable vapours and liquids in the vicinity of this or any other gas fired appliance.

WHAT TO DO IF YOU SMELL GAS:

- Do not try to light any appliance
- Do not touch any electrical switch; do not use any phone in your building
- Immediately call your gas supplier from a neighbor's phone. Follow the gas supplier's instructions.
- If you cannot reach your gas supplier, call the fire department.

Installation and service must be performed by a qualified installer, service agency or the gas supplier.



INSTALLER: Leave this manual with the appliance.

CONSUMER: Retain this manual for future reference.

FIELD CONVERTIBILITY:
This appliance is field convertible to LP gas.
Use only the optional gas conversion kit available from the manufacturer.

Keep this manual in a secure place .
Record for future reference:

Model #: _____

Serial #: _____

(located on heater rating label)

GAS-FIRED



NOTICE:

This manual is current for this product.

This publication, or parts thereof, may not be reproduced in any form, without prior written consent from The Manufacturer. Unauthorized use or distribution of this publication is strictly prohibited.

Schwank Group

Schwank and InfraSave brands

5285 Bradco Boulevard

Mississauga, Ontario, L4W 2A6

PO Box 988, 2 Schwank Way

Waynesboro, Georgia 30830

Customer & Technical Services

Phone: 877-446-3727

Fax: 866-361-0523

e-mail: csr@schwankgroup.com

www.schwankgroup.com

www.infrasave.com

INSPECT PRODUCT UPON RECEIPT

Inspect the carton and heater for concealed damage. Note any damage on the Bill of Lading and make any damage claim to the transport company as soon as possible.

P40-R, P40-IR GAS-FIRED VENTED OVERHEAD HEATER

TABLE OF CONTENTS

TOPIC PAGE	TOPICPAGE
<u>IMPORTANT INFORMATION - READ FIRST</u>			
OPERATING INSTRUCTIONS	4	16. HIGH ALTITUDE INSTALLATION.....	27
SAFETY WARNINGS	5	17. LIGHTING INSTRUCTIONS	27
START UP 'SMOKE'	6	18. RECOMMENDED MAINTENANCE	28
FLUE VENTING	6, 19	19. FENWAL DSI: WIRING DIAGRAM	29
THERMOSTAT COMFORT SETTING	5	20. MULTIPLE HEATERS/T-STAT: WIRING DIAGRAM	30
GAS CONNECTION	7, 25	21. SEQUENCE OF OPERATION: FENWAL DSI	31
CLEARANCE TO COMBUSTIBLES	7 - 10	22. HONEYWELL DSI: WIRING DIAGRAM	34
Clearances: Figures & Table	8 - 9	23. SEQUENCE OF OPERATION: HONEYWELL DSI	35
STACKING HEIGHT SIGN	9	24. CHANNEL MICRO 50N DSI: WIRING DIAGRAM	37
VENT CLEARANCE	10, 20 - 22	25. SEQUENCE OF OPERATION: MICRO 50N DSI	37
1. APPLICATION	11	26. SPARK IGNITION CIRCUIT	40
2. LABOR REQUIREMENTS.....	12	27. SPARK IGNITER ADJUSTMENT	40
3. INSTALLATION IN AIRCRAFT HANGARS... ..	12	28. TROUBLESHOOTING GUIDE	41
4. INSTALLATION IN COMMERCIAL GARAGES	12	29. START- UP / COMMISSIONING SHEET	43
5. INSTALLATIONS OTHER THAN SPACE HEATING	12	<u>PRODUCT DIMENSIONS & DATA</u>	
6. PRE-INSTALLATION SURVEY	13	30. HEATER DIMENSIONS / WEIGHTS	45
7. MOUNTING CLEARANCES	13	31. HIGH ALTITUDE & ORIFICE CHART	46
8. SERVICE CLEARANCE	13	32. OPTIONAL ACCESSORIES	47 - 49
9. HEATER PLACEMENT GUIDELINES	14	33. REPLACEMENT PARTS LIST	50 - 52
10. HEATER INSTALLATION.....	15	WARRANTY STATEMENT.....	BACK PAGE
10-A SEISMIC RESTRAINT.....	18		
10-B HIGH WIND RESTRAINT	18		
11. FLUE VENTING	19		
Side Wall Horizontal Vent	20 - 21		
Horizontal Vent Terminal Location	22		
Vertical Vent Through Roof	23		
12. COMBUSTION AIR REQUIREMENTS.....	24		
13. GAS SUPPLY & CONNECTION.....	25		
ORIENTATION OF FLEXIBLE GAS CONNECTION (<i>if applicable</i>)	26		
14. GAS CONVERSION	27		
15. ELECTRICAL AND THERMOSTAT	27		

FOR YOUR SAFETY READ BEFORE OPERATING

WARNING: If you do not follow these instructions exactly, a fire or explosion may result causing property damage, personal injury or loss of life.

- A. This appliance does not have a pilot. It is equipped with an ignition device which automatically lights the burner. Do not try to light the burner by hand.
- B. BEFORE OPERATING smell all around the appliance area for gas. Be sure to smell next to the floor because some gas is heavier than air and will settle on the floor.

WHAT TO DO IF YOU SMELL GAS

- Do not try to light any appliance.
- Do not touch any electric switch; do not use any phone in your building
- Immediately call your gas supplier from a neighbor's phone. Follow the gas supplier's instructions.



• If you cannot reach your gas supplier, call the fire department.

- C. Use only your hand to push in or turn the gas control knob. Never use tools. If the knob will not push in or turn by hand, don't try to repair it, call a qualified service technician. Force or attempted repair may result in a fire or explosion.
- D. Do not use this appliance if any part has been under water. Immediately call a qualified service technician to inspect the appliance and to replace any part of the control system and any gas control which has been under water

OPERATING INSTRUCTIONS

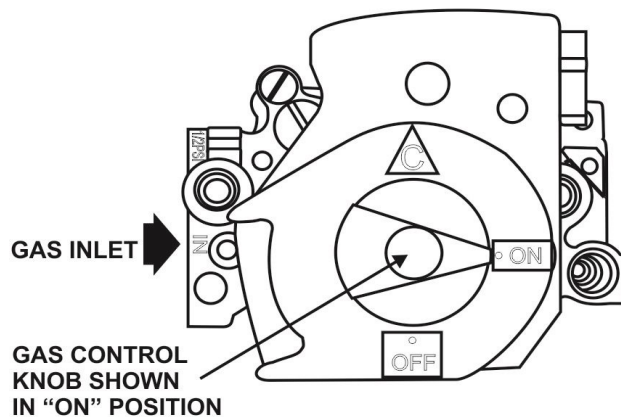
1. STOP! Read the safety information above on this label.
2. Set the thermostat to lowest setting.
3. Turn off all electric power to the appliance.
4. This appliance is equipped with an ignition device which automatically lights the burner. Do not try to light the burner by hand.



5. Remove screw at upper juncture of burner housing and fold down.
6. Turn gas control knob clockwise  to "OFF". Do not force.
7. Wait five (5) minutes to clear out any gas. Then smell for gas, including near the floor. If you smell gas, STOP! Follow "B" in the safety information above on this label. If you don't smell gas, go to the next step.
8. Turn gas control knob counterclockwise  to "ON".
9. Re-fasten Burner housing in closed position.
10. Turn on all electric power to the appliance.
11. Set thermostat to desired setting.
12. If the appliance will not operate, follow the instructions "To Turn Off Gas To Appliance" and call your service technician or gas supplier.

TO TURN OFF GAS TO APPLIANCE

1. Set the thermostat to lowest setting.
2. Turn off all electric power to the appliance if service is to be performed.
3. Remove screw at upper juncture of burner housing and fold down.
4. Turn gas control knob clockwise  to "OFF". Do not force.
5. Re-fasten Burner housing in closed position.



WARNING



- Improper installation, adjustment, alteration, service or maintenance can cause property damage, injury or death. Read and understand this installation and operation manual thoroughly prior to assembly, installation, operation or service to this appliance.



- Installation and repair must be done by a qualified service person. The appliance should be inspected before use and at least annually by a qualified service person. More frequent cleaning may be required due to excessive dust from activities in the heated space. It is imperative that control compartments, burners and air circulating passageways of the appliance be kept clean.



- Do not store or use gasoline or other flammable vapours and liquids in the vicinity of this or any other gas fired appliance.
- Due to high temperatures, this appliance should be located out of traffic and away from furniture and draperies.
- Children and adults should be alerted to the hazards of high surface temperatures and should stay away to avoid burns or clothing ignition.
- Young children should be carefully supervised when they are in the same room as the heater.
- Clothing or other flammable material must not be placed on or near the appliance.
- Any safety screen or guard removed to service an appliance must be replaced prior to operating the appliance.
- This appliance has a blocked vent shut-off system (pressure switch). If the vent becomes blocked, the heater will not ignite. Do not tamper with this system. In the event that the appliance fails to operate, contact a qualified service agency.
- Do not use this appliance if any part has been under water. Immediately call a qualified service technician to inspect the appliance and to replace any part of the control system and any gas control which has been under water.
- Failure to comply to these instructions could result in personal injury, death, fire and/or property damage.
- This appliance may have sharp edges and corners. Wear protective clothing such as gloves and protective eye wear when installing or servicing this appliance.



WARNING

Improper installation, adjustment, alteration, service or maintenance can cause property damage, injury or death. Read and understand this installation and operation manual thoroughly prior to assembly, installation, operation or service to this appliance.



This heater must be installed and serviced only by a trained gas service technician.



Do not store or use gasoline or other flammable vapours and liquids in the vicinity of this or any other gas fired appliance.

Failure to comply could result in personal injury, death, fire and/or property damage.



Do not store or use gasoline or other flammable vapours and liquids in the vicinity of this or any other gas fired appliance.

This appliance may have sharp edges and corners. Wear protective clothing such as gloves and protective eye wear when installing or servicing this appliance.

California Proposition 65:



WARNING: This product can expose you to chemicals including carbon monoxide, which is known to the State of California to cause birth defects or other reproductive harm. For more information, go to www.P65Warnings.ca.gov



CAUTION

Start Up 'SMOKE' Condition

During start up, the heating of material coatings used in the production process of tubes and reflectors will create smoke during the initial period of operation. This condition is normal and temporary .

Ensure that there is sufficient ventilation to adequately clear any smoke from the space.

Check to ensure that any alarm system is not unduly activated during start up.



WARNING

Venting



Inadequate venting of a heater may result in asphyxiation, carbon monoxide poisoning, injury or death. Combustion products from this heater must be vented from the space. Venting must be in accordance with all local, state, provincial, and national codes (ANSI Z223.1/NFPA 54 in USA; B149.1 in Canada) and as indicated in this manual.

Refer to Sections 11 & 12



IMPORTANT

THERMOSTAT SETTING FOR COMFORT

Infrared radiant (IR) heating system provide comfort with the effect of radiant heat and ambient air heat.

If your IR system is controlled with a TruTemp thermostat that senses radiant heat, then set the thermostat to the desired comfort temperature (ie: 65°; 68°; 20°C).

If your IR system is controlled with a standard 24V or 120V thermostat that senses only air temperature, then start with a thermostat setting that is 5° to 7°F (3° to 5°C) lower than the desired comfort temperature. Some trial and error setting may be required to 'fine tune' the comfort temperature that best suits your site and provides most economical operation.



WARNING

Gas Connection



Improper installation, connection, or adjustment can result in property damage, toxic gases, asphyxiation, injury or death. The gas supply must be connected and tested in accordance with all local, state, provincial, and national codes (*ANSI Z223.1/NFPA 54* in USA; *CSA B149.1* in Canada).

Refer to Section 13



WARNING

Clearance to Combustibles

Location of flammable or explosive objects, liquids or vapors close to the heater may cause fire or explosion and result in property damage, injury or death. Do not use, store or locate flammable or explosive objects, liquids or vapors in the proximity of the heater.



The clearance to combustible material represents the minimum distance that must be maintained between the outer heater surface and a nearby surface. The stated clearance to combustibles represents a surface temperature of 117F° (65C°) above room temperature. It is the installer's responsibility to ensure that building materials with a low heat tolerance which may degrade at lower temperatures are protected to prevent degradation. Examples of low heat tolerance materials include vinyl siding, fabrics, some plastics, filmy materials, etc.

IMPORTANT: A peel and stick sign is included with this heater to specify the required clearances from the heater to any combustible materials or vehicle. **The sign must be posted either adjacent to the heater thermostat or in the absence of such thermostat in a conspicuous location.** In addition to stored or stationary material, consideration must also be given to moveable objects such as vehicles and overhead doors, and structural objects such as shelving, sprinkler heads, electrical and gas lines, and electrical fixtures.

Do not store any combustible materials or install shelving or other projections within the "Clearance to Combustibles" box - see Figure 1 and Table 1 on the next pages.

It is beyond the scope of these instructions to consider all conditions that may be encountered.

Consult local authorities such as the Fire Marshall, insurance carrier, or safety authorities if you are uncertain as to the safety or applicability of the proposed installation.

Refer to Figure 1 and Table 1 in this manual, and/or the rating label affixed to the burner housing for the certified clearances to combustibles for the heater.

FIGURE 1 MINIMUM CLEARANCES TO COMBUSTIBLES* 3D VIEW - Table 1 also lists values next page



Always maintain at least the minimum clearance from any combustible material or vehicle.

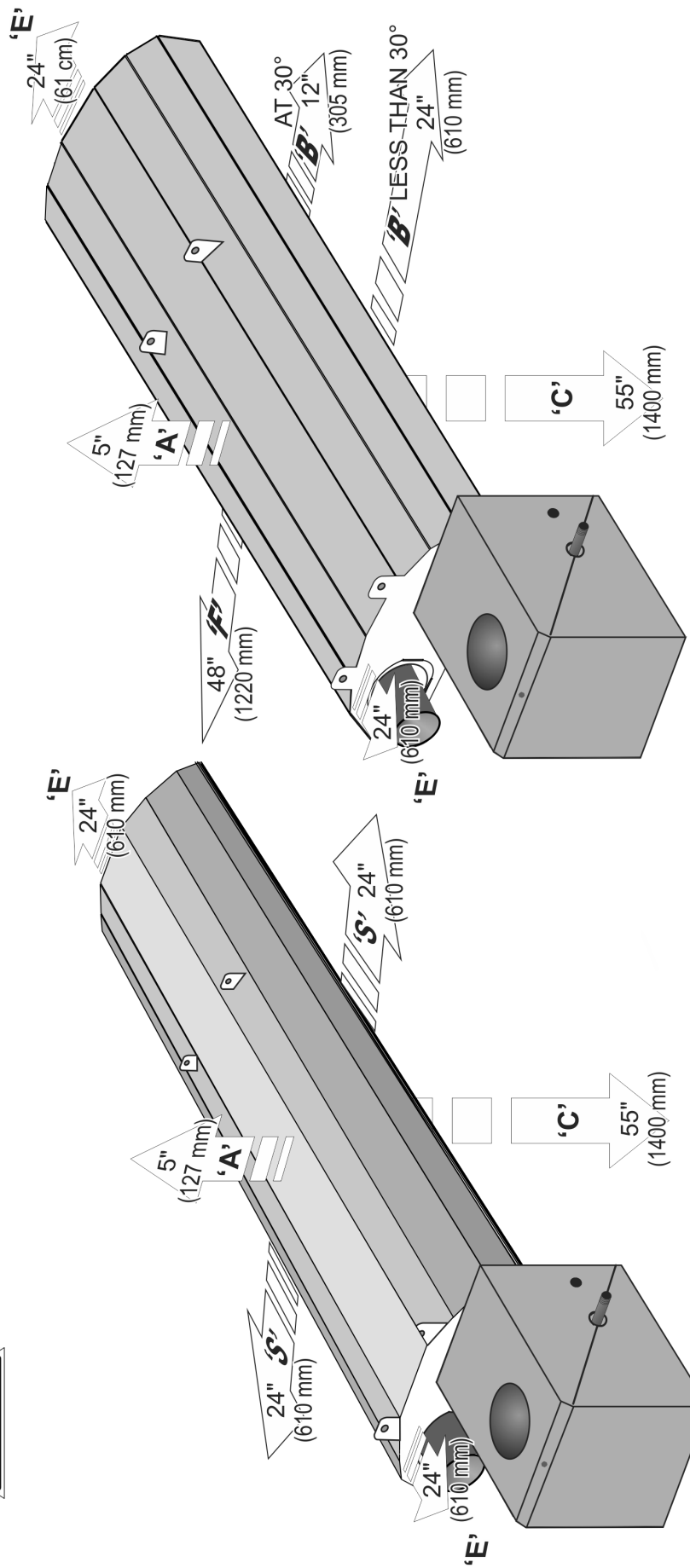

TUBE/REFLECTOR MOUNTED HORIZONTALLY

TUBE/REFLECTOR MOUNTED UP TO 30° ANGLE (EITHER DIRECTION)

TABLE 1 MINIMUM CLEARANCES TO COMBUSTIBLE SURFACES OR MATERIALS*

MODEL	SUSPENDED HORIZONTALLY			SUSPENDED AT AN ANGLE UP TO 30 DEGREES				
	A: TOP inches (mm)	C: BELOW inches (mm)	S: SIDES inches (mm)	A: TOP inches (mm)	C: BELOW inches (mm)	F: FRONT inches (mm)	B: BACK AT 30° inches (mm)	B: BACK < 30° inches (mm)
P40-R	5 (127)	53 (1350)	24 (610)	5 (127)	53 (1350)	48 (1220)	12 (305)	24 (610)
	E: ENDS of Reflector : 24" (610 mm) (horizontal or angled)							

*The clearance to combustibles materials represents the minimum distance that must be maintained between the heater and a nearby surface. **The stated clearance to combustibles represents a surface temperature of 117F° (65C°) above room temperature.**

It is the installer's responsibility to ensure that building materials with a low heat tolerance which may degrade at lower temperatures are protected to prevent degradation. Examples of low heat tolerance materials include vinyl siding, fabrics, some plastics, filmy materials, some coatings and laminated finishes, etc.

FIGURE 2 MINIMUM CLEARANCES TO COMBUSTIBLES* END VIEW - See Table 1 above

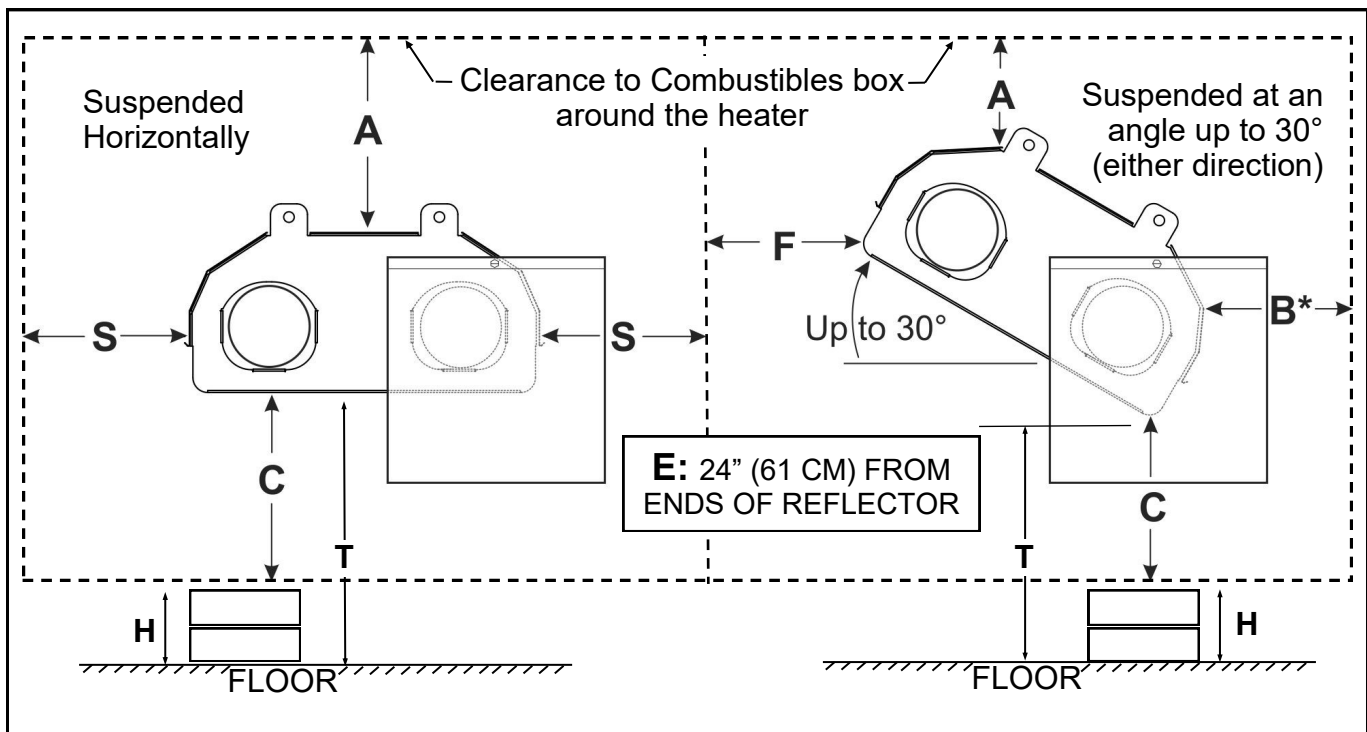

Calculate Maximum Stack Height 'H': (Enter value 'H' on the peel and stick label supplied)

- 53 inches (135 cm) is the required minimum clearance below the heater ('C')
- 'T' is measured on site = distance from the bottom of the heater hanger to the floor
- $H = T - 53$ inches (135 cm): Do not stack or store higher than 'H' under the heater
- Do not place or store materials or shelving within the Clearance to Combustibles Box represented by the dotted lines in Figure 2 above



WARNING

For your convenience a “peel and stick” sign is provided with this heater. This sign must be posted either adjacent to the IR heating system thermostat or in the absence of such thermostat, in a conspicuous place specifying the required clearances from the heater to the combustibles.

Use a permanent marker to record the required clearance dimensions on the sign.

‘H’ is a value calculated at site: $(H = T - C)$ Refer to Figure 1 and Table 1 above

- Measure the on site distance between bottom of the heater and the floor = ‘T’ inches (cm).
- The minimum clearance to combustibles below this heater ‘C’ is **53 inches (1346 cm)**
- Subtract ‘C’ 53 inches (1346 mm) from ‘T’ (Height above floor) to get value ‘H’.
- Enter the calculated value ‘H’ on the sign

Enter the values as required for the other dimensions:

‘S’ = 24” (610 mm)

‘F’ = 48” (1120 mm)

‘B’ = 12” (305 mm) at 30°

Or ‘B’ = 24” if mount angle less than 30°

POST THIS SIGN ADJACENT TO THE HEATER THERMOSTAT OR IN A PROMINENT LOCATION.

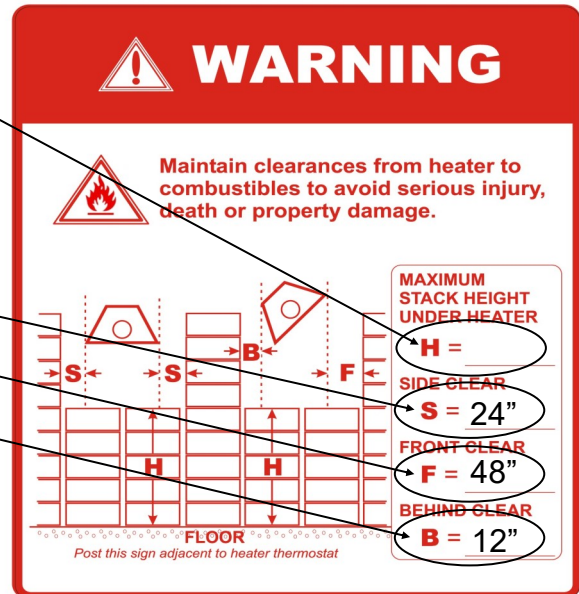

VENT CLEARANCE: Clearance from single wall ‘C’ vent pipe inside the building is determined by local or national installation codes, but must not be less than 6 inches (150 mm).

Clearance from the vent terminal outside the structure are indicated in Section 11 Flue Venting and Figures 9 to 12, pages 19 to 23 for details and requirements for venting.

1. APPLICATION

Model P40-R has been design certified to ANSI Z21.86 / CSA 2.32 Vented Gas-Fired Space Heating Appliances (Vented Overhead Heater).

Model P40-R may be installed for heating of an indoor residential garage, workshop, or greenhouse. This heater can also be installed in light commercial / industrial locations. **CAUTION:** If outside combustion air is required for commercial / industrial application, use model P40U ... by the approval standard outside combustion air cannot be connected to model P40-R.

This heater must **not be installed in any dwelling area** of a residence, nor in a basement, mobile home, or recreational vehicle.

This heater is not for installation in a Class 1 or Class 2 explosive environment. If the application is in question, consult with local authorities having jurisdiction (Fire Marshall, inspection department, insurance underwriter, or other authority having jurisdiction).



- **Due to high temperatures, the appliance should be located out of traffic and away from furniture and draperies.**
- **Children and adults should be alerted to the hazards of high surface temperatures and should stay away to avoid burns or clothing ignition**
- **Young children should be carefully supervised when they are in the same room as the appliance**
- **Clothing or other flammable material should not be placed on or near the appliance**
- **Any safety screen or guard removed to service an appliance must be replaced prior to operating the appliance**
- **Installation and repair should be done by a qualified service person. The appliance should be inspected before use and at least annually by a qualified service person. More frequent cleaning may be required due to excessive dust or contaminants from activities in the area of the appliance. It is imperative that control compartments, burners and air passageways of the appliance be kept clean.**

It is beyond the scope of these instructions to consider all conditions that may be encountered.

Installation must conform with local building codes or, in the absence of local codes, with the National Fuel Gas Code, ANSI Z223.1/NFPA 54 in the U.S.A. or the Natural Gas and Propane Installation Code, CSA B149.1 in Canada. The latest edition Electrical Code ANSI/NFPA N0 70 in the U.S.A. and PART 1 CSA C22.1 in Canada must also be observed.

Installation of this heater must conform to all heating installation procedures in this manual including suspension, maintenance of clearance to combustibles, connection to the gas and electrical supplies, and ventilation.

Revisions to codes and/or standards, may require revision to equipment and installation procedures. In case of discrepancy, the latest codes, standards, and installation manual will take priority over prior releases.

2. LABOR REQUIREMENTS

Two persons are required to safely install this equipment. SHARP EDGES - Wear gloves and other required safety protection.

3. INSTALLATION IN COMMERCIAL AIRCRAFT HANGARS

Low intensity radiant tube heaters are suitable for use in aircraft hangars when installed in accordance with the latest edition of the Standard for *Aircraft Hangars*, ANSI/NFPA No 409 in the USA, or the Canadian *Natural Gas and Propane Installation Code*, B149.1.

- A. A minimum clearance of 10 ft (3 m) above either the highest fuel storage compartment or the highest engine enclosure of the highest aircraft which may occupy the hangar. The clearance to the bottom of the heater shall be measured from the upper surface of either the fuel storage compartment or the engine enclosure, whichever is higher from the floor.
- B. A minimum clearance of 8 ft (2.4 m) must be maintained from the bottom of the heater to the floor in other sections of the aircraft hangar, such as offices and shops, which communicate with areas for servicing or storage. Refer to Table 1 for proper mounting clearances to combustibles.
- C. Heaters must be located so as to be protected from damage by aircraft and other objects, such as cranes and movable scaffolding.
- D. Heaters must be located so as to be accessible for servicing and adjustment.

4. INSTALLATION IN COMMERCIAL GARAGES AND PARKING STRUCTURES

Low Intensity Heaters are suitable for use in commercial garages when installed in accordance with the latest edition of the Standard for *Parking Structures*, ANSI/NFPA 88A, or the Standard for *Repair Garages*, ANSI/NFPA No. 88B, or the Canadian *Natural Gas and Propane Installation Code*, B149.1.



WARNING

An overhead heater shall be located high enough to maintain the minimum distance to combustibles, as shown on the heater rating plate, from the heater to any vehicles parked below the heater.

Overhead heaters shall be installed at least 8 ft (2.4 m) above the floor in commercial garages and parking structures.

5. INSTALLATIONS OTHER THAN SPACE HEATING

Use for process or other applications that are not space heating will void the heater certification and product warranty. Process application requires field inspection and/or certification by local authorities having jurisdiction.

6. PRE INSTALLATION SURVEY

Carefully survey the area to be heated. It is recommended that a full heating design including heat loss calculation be conducted on the structure or area to be heated. Heater sizing, quantity, and placement must consider available mounting height, sources of greatest heat loss.

The certified clearances to combustibles must always be maintained with respect to stored material, moveable objects (vehicles, lifts, overhead doors, etc), sprinkler system heads, furniture and draperies, and other obstructions at the site. Consideration must also be given to vent placement and the allowable length of vent . (see section 11, page 19)

Installation must conform with all local, state, provincial and national code requirements including the current latest edition ANSI Z223.1 (NFPA 54) in the U.S.A. and B149.1 installation code in Canada, for gas burning appliances and equipment. The latest edition Electrical Code ANSI/NFPA N0 70 in the U.S.A. and PART 1 CSA C22.1 in Canada must also be observed.

The heating system must have gas piping of the correct diameter, length, and arrangement to provide adequate fuel supply and function properly. A dimensioned layout drawing is advised.

7. MOUNTING CLEARANCES

This heater must be mounted with at least the minimum clearances between the heater and combustibles as shown in FIG-1, TABLE 1, Pages 8 & 9. **It is the installer's responsibility to ensure that building materials with a low heat tolerance which may degrade at lower temperatures are protected to prevent degradation. Examples of low heat tolerance materials include vinyl siding, fabrics, some plastics, filmy materials, some coatings and laminated finishes, etc.**

Ensure adequate clearance around the air intake at the burner to allow sufficient combustion air supply to the heater.

Proximity of lights, sprinkler heads, overhead doors, storage areas, gas and electrical lines, parked vehicles, cranes and any other possible obstruction or hazard must be evaluated.

Place the heater so as not to cause a hazard to a wall, floor, shelving, curtains, furniture, or door when open, or impede the free movement of people.

It is recommended that Protective Guard JS-0502-UR-GK be installed on any heater mounted with less than 8 feet from floor to bottom of heater (See Accessories - Page 47).

8. SERVICE CLEARANCE: The lower 'jaw' of the burner cabinet swings down to provide convenient service access to burner components. Provide a minimum clearance from any wall or obstruction of 6 inches (15 cm) to the access end of the burner housing, and a minimum of 24 inches (61 cm) to any ONE side to allow burner service. (see Figure 2 below)

The minimum clearances to combustibles must always be maintained.

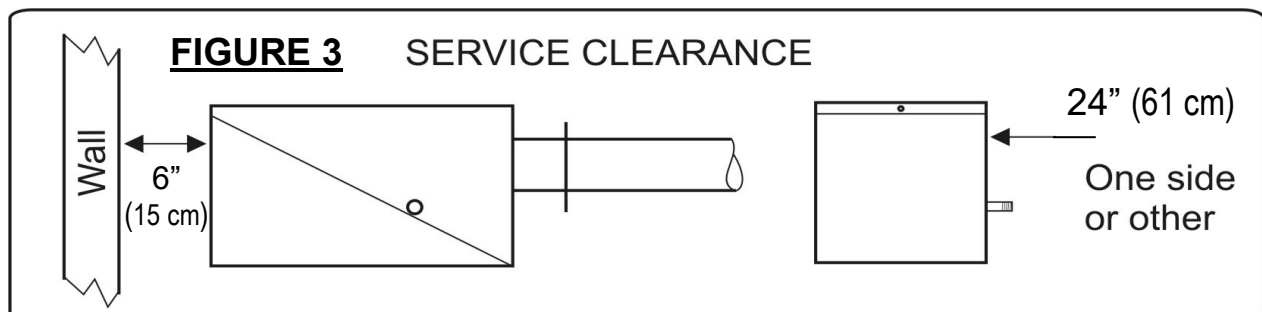

9. SUGGESTED GUIDELINES FOR HEATER PLACEMENT*
- SPACE HEATING APPLICATION

MODEL	GUIDELINE * MOUNTING HEIGHT ft (m)	DISTANCE – HEATER LONG AXIS PARALLEL TO WALL	
		HORIZONTAL ft (m)	ANGLE MOUNTED
P40-R	8 – 12 (2.4 - 3.7)	5 – 12 (1.5 - 3.7)	MINIMUM: COMBUSTIBLE CLEARANCE BEHIND 12” to 24” (305 to 610 mm)

* SUGGESTED GUIDELINE MOUNTING HEIGHTS are typical to provide optimum comfort in general space heating applications. Variance from these typical heights can occur in some applications:

- Higher mounting height due to structure or application requirements
- For ‘area’ or ‘spot’ heat, or in areas with greater infiltration rates (near overhead doors, etc) where more intense heat is needed to provide better comfort then lower mounting heights are recommended (minimum 8 ft [2.4 m] mounting height)
- It is recommended that Protective Guard JS-0502-UR-GK be installed on any heater mounted with less than 8 feet from floor to bottom of heater (See Accessories - Page 41)



IMPORTANT: Single or multiple heater placement must be such that continuous operation of heaters will not cause combustible material or materials in storage to reach a temperature in excess of ambient (room) temperature plus 117F° (65C°).

It is the installer’s responsibility to ensure that building materials with a low heat tolerance which may degrade at lower temperatures than the clearance temperature are protected to prevent degradation.

Examples of low heat tolerance materials include vinyl siding, fabrics, some plastics, filmy materials, etc.

Refer to “Clearance to Combustibles” information on pages 7 to 10, and Figure 1 and Table 1, and listed on the heater rating plate (on burner housing).

10. HEATER INSTALLATION



Inadequate or improper suspension of the tube heater can result in collapse of the system, property damage, and personal injury or death. Suspend the heater from a structural member that can adequately support the weight of the heater. Always maintain the required minimum clearances to combustible materials and vehicles (see pages 7 to 10).

It is the installer's responsibility to ensure that the hardware and structural supports from which the heater is suspended are sound and of adequate strength to support the weight [86 lb (39 kg)] and expansion forces of the heater.



USE CARE & CAUTION WHEN LIFTING HEATER FROM CARTON

1. DO NOT LIFT THE HEATER BY THE REFLECTOR

2. AT LEAST 2 PERSONS ARE REQUIRED TO LIFT AND INSTALL THIS HEATER

3. CHAINS ARE PROVIDED FOR TON AND FOR HANDLING PURPOSES

4. WHEN HANDLING HEATER HANDLE BY TUBE NOT REFLECTOR

5. LIFT BOTH ENDS FROM CARTON AT THE SAME TIME. KEEP THE HEATER HORIZONTAL / LEVEL THROUGHOUT ITS LENGTH WHILE HANDLING AND INSTALLATION.

6. LIFT SAFELY - LIFT WITH YOUR LEGS / KNEES - KEEP BACK STRAIGHT - DO NOT BEND OR TWIST.

7. BEWARE - SHARP EDGES! WEAR PROTECTIVE GLOVES AND CLOTHING WHEN HANDLING

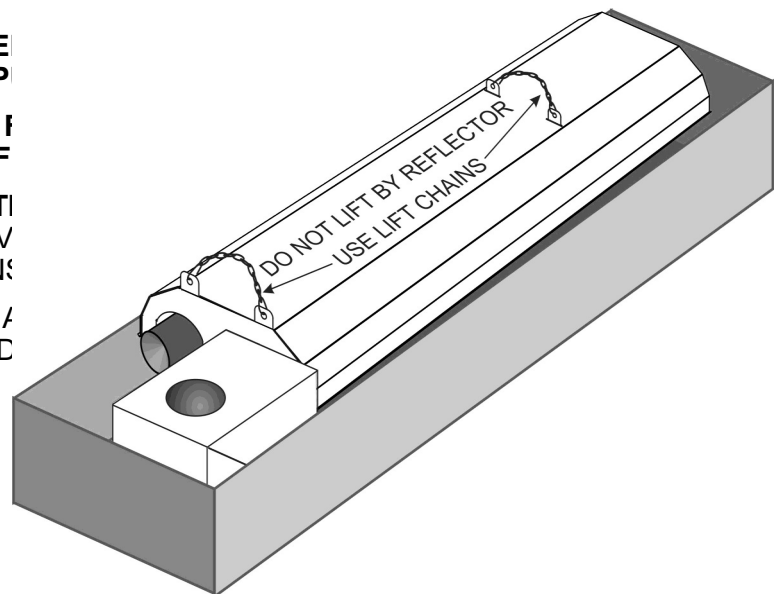
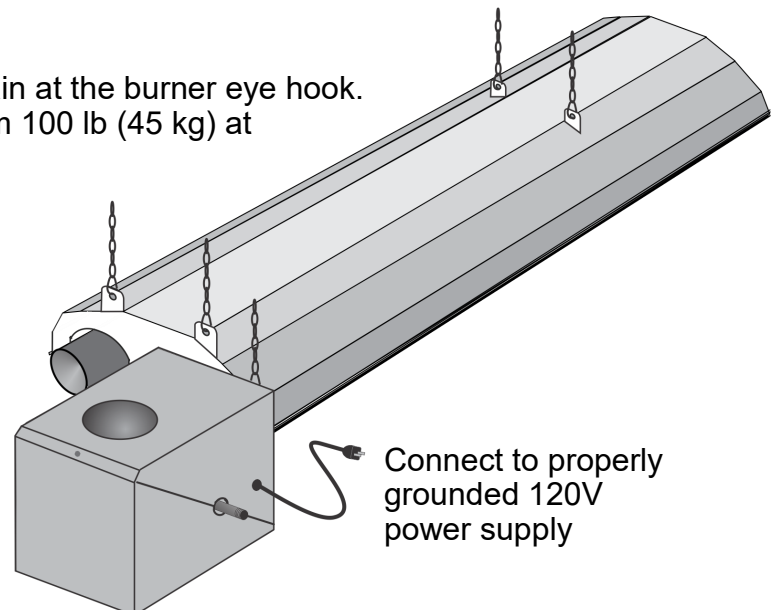

FIGURE 4 TYPICAL SUSPENSION

Use all four suspension points *plus* a chain at the burner eye hook. Hardware capable of supporting minimum 100 lb (45 kg) at each suspension point. For seismic and high wind restraint see Sections 10-A & 10-B.

SERVICE ACCESS: ALLOW A MINIMUM OF 6 INCHES (15 cm) FROM THE ACCESS END OF THE BURNER AND A MINIMUM OF 24 INCHES (60 cm) FROM EITHER SIDE OF THE BURNER TO A WALL OR ANY OBSTRUCTION THAT WOULD RESTRICT OR LIMIT ACCESS TO THE BURNER (SEE SECTIONS 6 & 7 - PRE-INSTALLATION SURVEY AND MOUNTING CLEARANCES)



IMPORTANT: READ FIRST: Review the information on pages 4 to 10 and ensure that installation adheres to the instructions in this manual, and all national and local codes.

Refer to pages that follow for illustrations and dimensions that assist in installation.

1. Survey the available structural support, considering the system configuration and heat requirements of the area to establish the optimum heater location.
2. Hardware with a minimum 100 lb. (30 kg) work load must be used at each heater suspension point. A #2 Lion Chain or equivalent is typically used to suspend the heater.
 - b) If rigid hardware such as 3/8" threaded rod is used for suspension, swing joints or other means must be provided to allow for system expansion - approximately 1/2 inch
3. The heater must be supported at all four mounting tabs on the hangers that are located 72 inches (183 cm) apart .
4. Locating a heater directly under joists or beams, and/or installing supplemental support such as angle iron can ensure the integrity of the installation.
5. The heater can be mounted with the tube/reflector in a horizontal position, or at 30° facing toward the area to be heated. The burner must always be level (length and width) to ensure proper operation of air switches and gas valve.
6. Install the structural fastening hardware and any suspension hardware (chain, etc) prior to removing heater from the carton. Ensure that the support hardware system is firmly fastened to a structural member(s) of sufficient strength and integrity to support the weight of the heater.
7. The heater comes fully assembled from the factory. For locations where there is constrained access for installation, removal of the burner assembly may assist in the installation of the tube/reflector assembly. Disconnect the spark wire from the igniter and remove the four nuts that fasten the burner to the tube flange. Re-install the burner after the tube system is installed. If the tube/reflector system is to be oriented up to a 30° mounting angle (see below), the burner must be adjusted to a horizontal position for operation.

Up to 30° Angle Mounting: See Figure 6 *next page*

8. The tube/reflector system can be oriented on the short axis from horizontal to an angle up to 30 degrees in either direction with the burner in the upper or lower position. The heater must be level along its length, and the burner positioned level across its width.
9. If the tube/reflector assembly is to be suspended at an angle up to 30°, the burner mounting flange has a slot pattern that allows adjustment (rotation) of the burner to a horizontal position for proper operation - **BURNER MUST BE HORIZONTAL ACROSS THE WIDTH** (see Figure 6 below).
 - Install the tube/reflector system as above, with tube/reflector assembly angled up to 30°
 - Loosen the 4 nuts (2 or 3 turns) until burner studs can rotate within the flange slots
 - CAUTION: Use care to ensure that the gasket between burner and flange rotates with the burner and is not damaged
 - Rotate burner to level position across its width
 - Tighten the 4 nuts to secure the burner in the horizontal position
10. For seismic and high wind restraint see Sections 10-A & 10-B, page 19.

FIGURE 5 HEATER DIMENSIONS

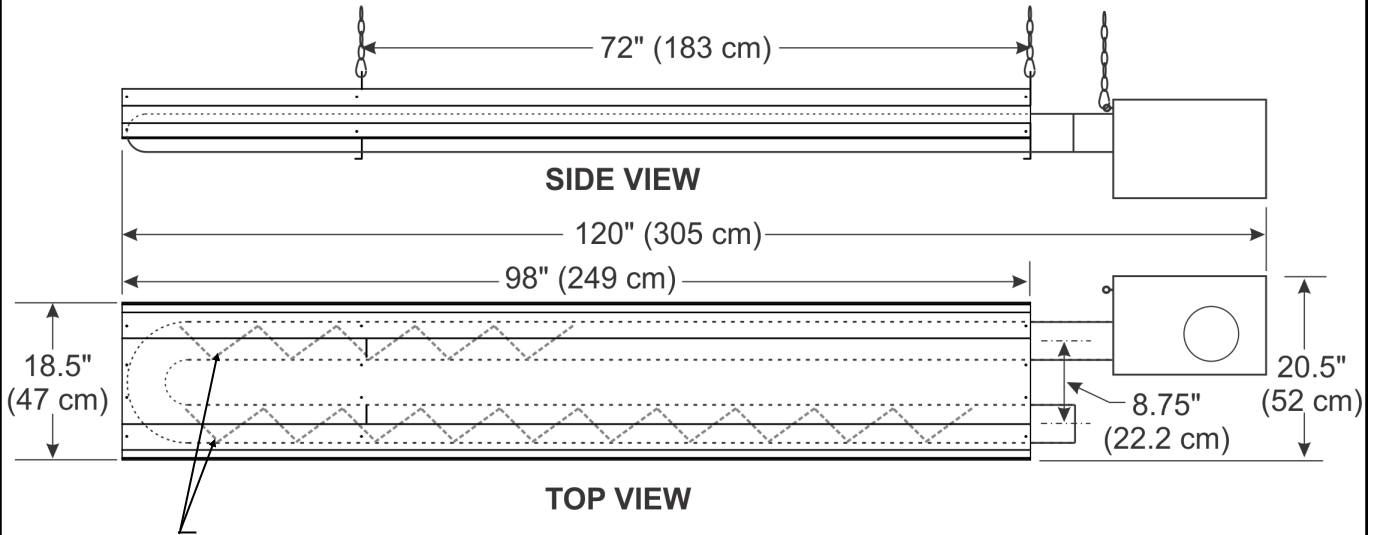

Turbulators (factory installed in tube): Burner side tube: 39" (99 cm)

FIGURE 6 HEATER SUSPENSION: HORIZONTAL; UP TO 30° ANGLE

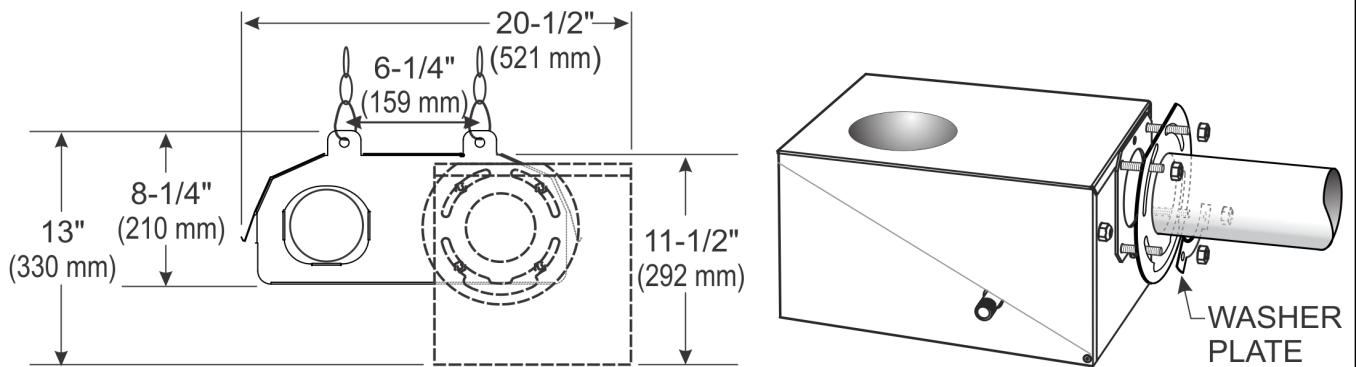

SLOTS IN TUBE FLANGE ALLOW BURNER ROTATION & HEATER SUSPENSION UP TO 30°

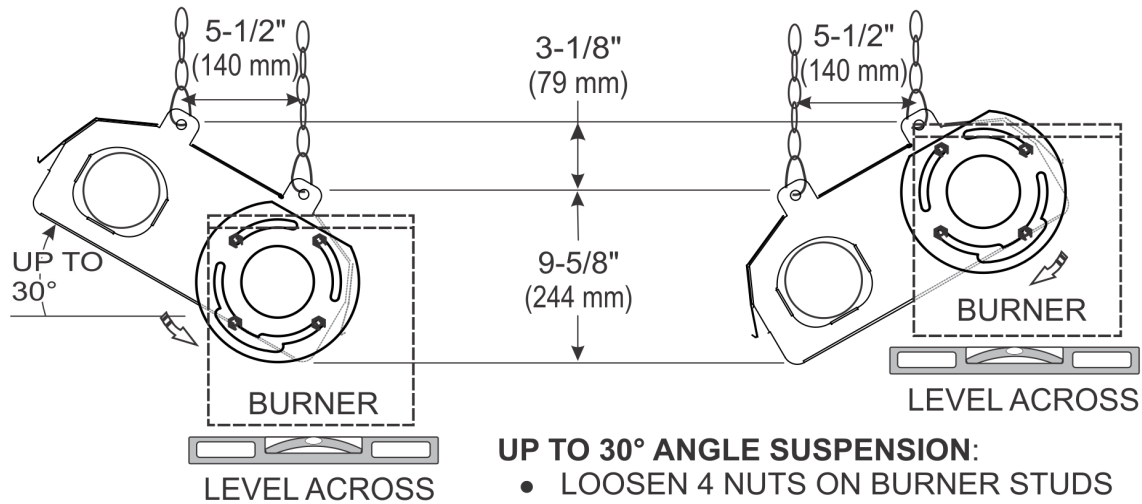

UP TO 30° ANGLE SUSPENSION:

- LOOSEN 4 NUTS ON BURNER STUDS
- USE CARE NOT TO DAMAGE GASKET
- ROTATE BURNER TO LEVEL POSITION
- TIGHTEN NUTS TO SECURE

10-A SUGGESTED SEISMIC RESTRAINT - Lateral and Longitudinal Planes

NOTE: Seismic restraint requirements vary greatly by geographic region or area. The information below is a guideline only for suspension of the heater. Adhere to specific seismic requirements and specifications of local engineering authority.

In areas prone to earthquake, or specified on a project, install lateral and longitudinal seismic restraints as suggested in Figure 7. If the heater location can be impacted by wind (near overhead doors, aircraft hangars, outdoors, etc) refer to High Wind Restraint section **10-B** below.

These guidelines indicate attachment of suspension and restraint hardware to the heater. The attachment of suspension hardware to the structure will be as required by site structural conditions, installation codes, and/or local engineering specifications. Other types or systems of restraint that are specified by local or national codes, or by project engineering design specifications may be required .

All required seismic mounting hardware is field supplied by the installer according to local specifications.

FIGURE 7

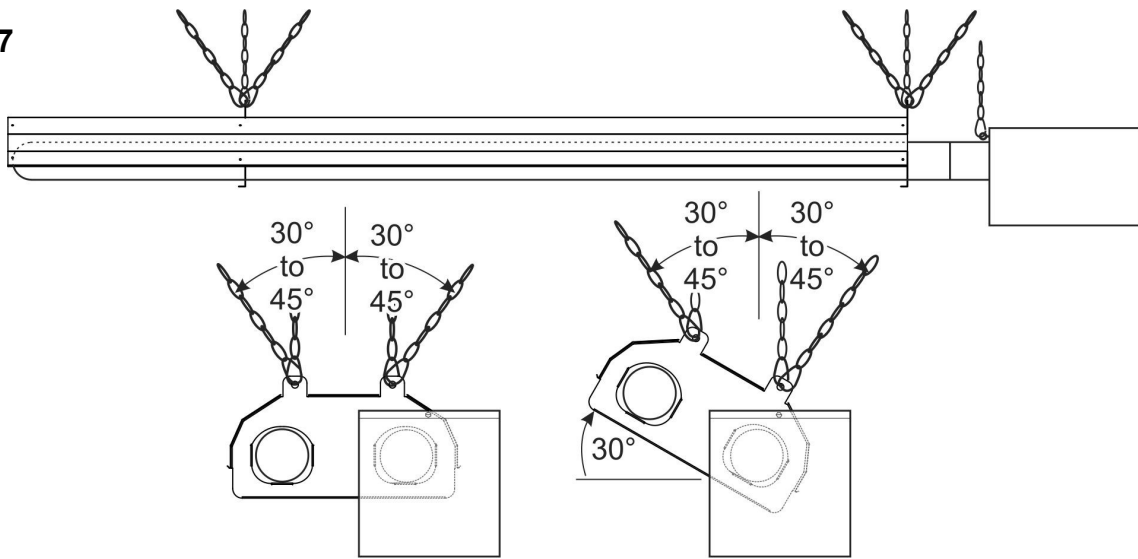

10-B SUGGESTED HIGH WIND RESTRAINT: Lateral, Longitudinal, and Vertical Planes

In areas with wind conditions that can impact the heater (outdoor, aircraft hangars, etc): in addition to lateral and longitudinal restraint the heater should be restrained from vertical movement (lift).

FIGURE 8

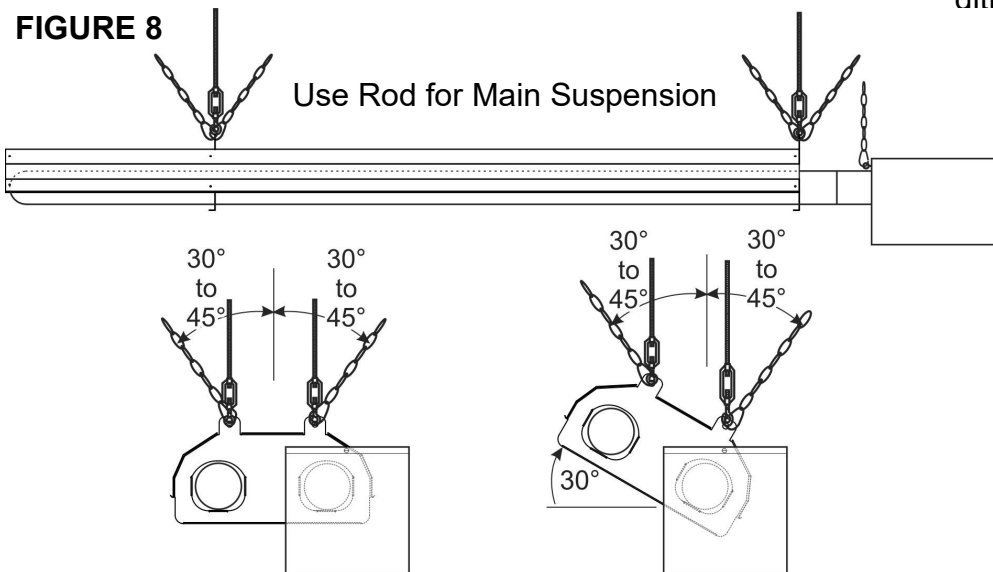

Use Rod for Main Suspension

In addition to lateral and longitudinal restraint the heater should be restrained from vertical movement (lift).

Suspend the heater using 3/8" threaded rod with 3" adjustment turnbuckle at each hanger location to restrain up-and-down movement.

Install angled chains for lateral and longitudinal restraint.



WARNING

11. FLUE VENTING



Inadequate venting of a heater may result in asphyxiation, carbon monoxide poisoning, injury or death. This heater must be connected to a vent to remove products of combustion from the space. Seal all vent connections with high temperature sealant. Venting must be in accordance with all local, state, provincial, and national codes (ANSI Z223.1/NFPA 54 in USA; B149.1 in Canada) and as indicated below in this manual.

THIS HEATER MUST BE VENTED DIRECTLY TO THE OUTSIDE. THE SYSTEM MUST NOT BE OPERATED WITHIN A NEGATIVE AIR CONDITION. ENSURE ADEQUATE AIR SUPPLY TO THE SPACE TO ENSURE THERE IS NO NEGATIVE AIR CONDITION (NEGATIVE PRESSURE IN THE SPACE BEING HEATED).

THIS GAS APPLIANCE MUST NOT BE CONNECTED TO A CHIMNEY FLUE SERVING A SEPARATE SOLID-FUEL BURNING APPLIANCE.

GENERAL FLUE VENTING REQUIREMENTS

It is the sole responsibility of the installer to adhere to all current local codes and/or ANSI Z223.1 / CSA.B149.1 latest editions for all venting requirements, and practices.

It is a normal condition that during heat-up and cool-down a tube heater will expand and contract. Allowances for heater expansion must be made in the venting. Improper installation can result in property damage, injury or death.

- This heater has a positive vent pressure
- A vent termination cap is recommended for use with horizontal side wall vent
- All vent pipe and adapters will be supplied locally by others
- Vent pipe must be minimum 26 gauge single wall type “C” vent pipe of 4” (10 cm) diameter except that portion of vent passing through the wall or roof shall be 4” type “B” vent
- A minimum 12 inch (30 cm) length of minimum 26 gauge single walled 4” (10 cm) diameter “C” vent pipe is to be installed on the swaged end of the tube before any vent elbow is fitted.
- **Seal all vent connections with high temperature sealant.** Vent connections must be secured with three (3) #8 sheet metal screws uniformly spaced around the circumference of the vent pipe.
- When the vent pipe passes through a cold or unheated area where the ambient temperature is likely to produce condensation of the flue gases, the vent pipe will be insulated with a suitable material as approved and specified by the insulation manufacturer to withstand temperature up to 460°F (238°C).
- The vent system must **always** be adequately supported to prevent sagging.
- Refer to next pages for minimum and maximum vent length requirements:
 - Horizontal side wall vent: Pages 20 - 21
 - Vertical roof vent: Page 23

FIGURE 9 - Horizontal Vent - ALL vent pipe and adapters are field supplied

Through Combustible Wall
Using Schwank/InfraSave
Horizontal Vent Terminal JA-0528-XX

A wall thimble is not required through a non-combustible wall. Seal pipe penetration.

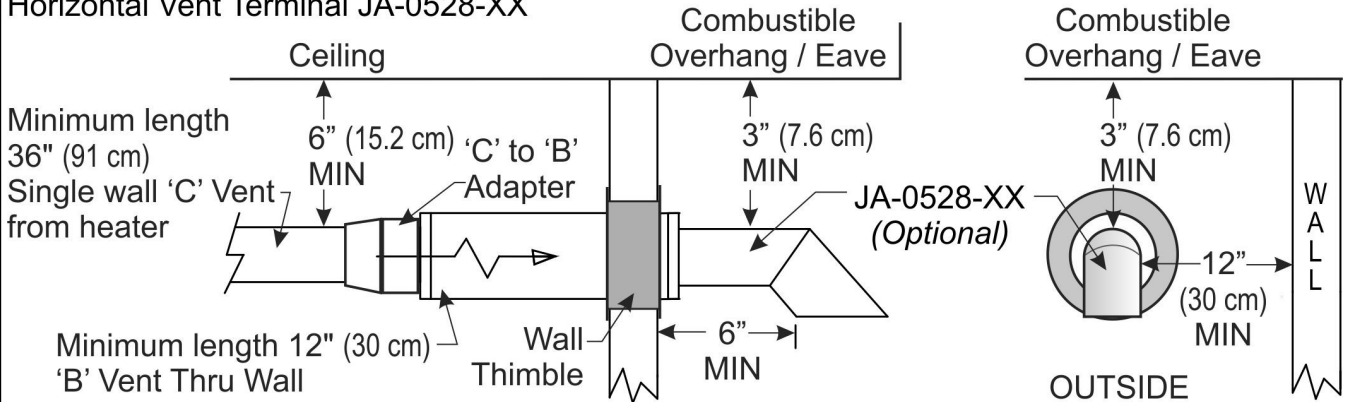

Seal all vent connections with high temperature sealant.

Through Combustible Wall
Using "High Wind" Vent Terminal

Minimum length 36" (91 cm)
Single wall 'C' Vent from heater
PLUS
Minimum length 12" (30 cm)
'B' Vent Thru Wall

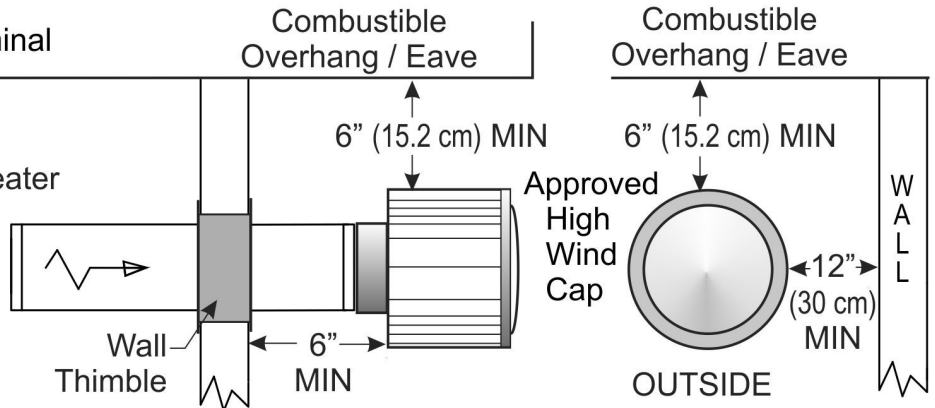
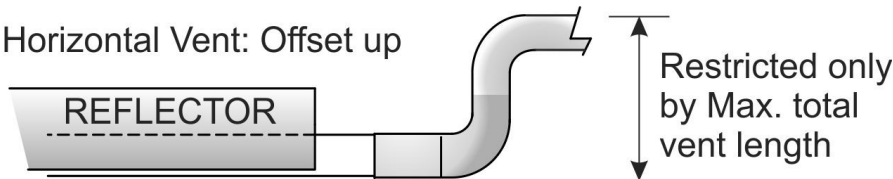

FIGURE 10 - Horizontal Vent Offset

SIDE VIEWS

Horizontal Vent: Offset up



Allow free expansion and contraction of the system, and free flow of vent gas.

Horizontal Vent: Offset down

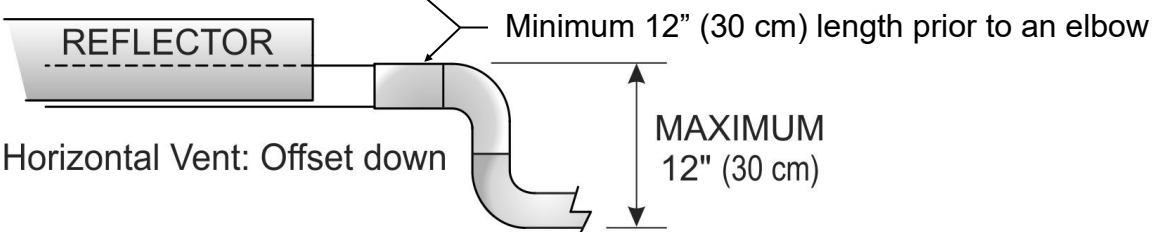

All Vent Pipe & Adapters Field Supplied

Seal all vent connections with high temperature sealant.

continued

HORIZONTAL VENT THROUGH A SIDE WALL: (*Vertical vent through roof is on page 23*)

- Refer to General Venting Requirements on page 19
- **Seal all vent connections with high temperature sealant.**
- Minimum length of a horizontal side-wall vent:
 - Regardless if a 90° elbow is installed, a Minimum linear 36 inch (3 ft; 91 cm) single wall 'C' vent *plus* minimum 12 inch (30.5 cm) double wall 'B' vent through wall
 - Total minimum linear vent length of 48 inches (4 ft; 122 cm)
- Maximum length of a horizontal side-wall vent:
 - Total Maximum vent length is 15 ft (4.6 m)
 - Each 90° or 45° elbow is equivalent to 5 ft
 - A minimum 12 inch (30.5 cm) double wall 'B' vent must be used through the wall
- The flue vent system must slope downwards approximately 1/4" per foot (63 mm / 300 mm) toward the vent terminal, from the termination of the tube - radiant tube must be level.
- A maximum of two elbows (90° or 45°; each = equivalent 5 ft) can be installed in a horizontal vent
- For side wall venting use either Schwank/InfraSave 4" (10 cm) horizontal vent terminal (Part Number: JA-0528-XX - available as an option) or an approved 4" (10 cm) "High Wind" vent termination cap (see clearance information previous page and next page)
- Install the termination cap a minimum of 6 inches (15 cm) from the outside wall to the inside edge of terminal opening to minimize back pressure caused by turbulent wind conditions (See Fig. 9 above). This also ensures flue gases are directed away from the structure to help protect building materials from degradation by the exhausted flue gases.
- The vent must be installed to prevent blockage by snow, undue wind pressure on the termination, and to protect building materials from degradation by flue gases.

Clearances Required for Horizontal Side Wall Vent :

- Refer to Figure 9 above, and in particular to Figure 11 and Table 3 next page for specific requirements of codes in the USA and Canada
- Any values not listed in Table 3 shall be in accordance with local installation codes and the requirements of the gas supplier

Footnotes for Table 3 (next page)

- ¹ *Installations in Canada in accordance with current CSA B149.1, Natural Gas and Propane installation Code*
 - ² *Installations in the USA in accordance with the current ANSI Z223.1 / NFPA 54, National Fuel Gas Code*
- † *A vent shall not terminate directly above a sidewalk or paved driveway that is located between two single family dwellings and serves both dwellings*
- ‡ *Permitted only if veranda, porch, deck, or balcony is fully open on a minimum of two sides beneath the floor*
- ** *Clearance in accordance with local installation codes and the requirements of the gas supplier.*

FIGURE 11: LOCATION OF HORIZONTAL (SIDE WALL) VENT TERMINAL

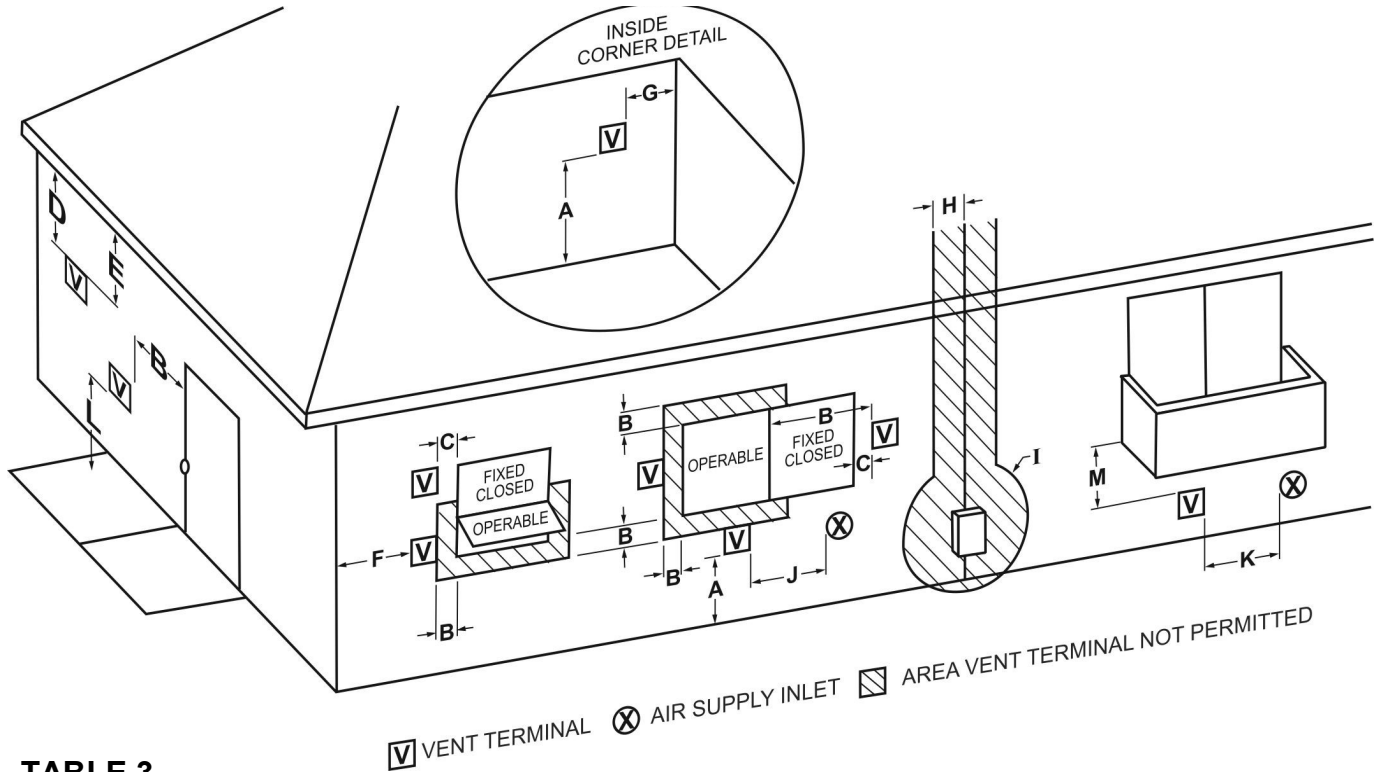

TABLE 3

	Clearance required:	Canada¹	USA²
A	Above grade, veranda, porch, deck, balcony	12" (30 cm)	12" (30 cm)
B	To a window or door that may be opened	12" (30 cm)	9" (23 cm)
C	To a permanently closed window	**	**
D	Below a ventilated soffit within 2 ft horizontal from center of terminal	12" (30 cm)	9" (23 cm)
E	Below an unventilated soffit	3" (7.6 cm)	3" (7.6 cm)
F	To an outside corner	12" (30 cm)	12" (30 cm)
G	To an inside corner	12" (30 cm)	12" (30 cm)
H	To each side of centerline extended above a meter/regulator assembly	3 ft (91 cm) within 15 ft (4.5 m) height above meter/regulator	**
I	To a service regulator vent outlet	3 ft (91 cm)	**
J	To non-mechanical air supply inlet or combustion air inlet to other appliance	12" (30 cm)	9" (23 cm)
K	To mechanical air supply inlet	6 ft (1.83 m)	3 ft (91 cm) above if within 10 ft (3 m) horizontally
L	Above sidewalk or paved drive on public property	7 ft (2.13 m) †	**
M	Under veranda, porch, deck, balcony	12" (30 cm) ‡	**

See Table footnotes previous page

VERTICAL VENT THROUGH THE ROOF: (*Horizontal vent through side wall is on pages 20 - 21*)

It is the sole responsibility of the installer to adhere to all current local codes and/or ANSI Z223.1 / CSA.B149.1 latest editions for all venting requirements, and practices.

- Refer to General Venting Requirements on page 19

Seal all vent connections with high temperature sealant.

- Any horizontal portion of vent must be minimum 26 gauge single wall type “C” vent pipe of 4” (10 cm) diameter (seal all connections); vertical portion of vent can be 4” type “B” vent
- When the vent pipe passes through a cold or unheated area where the ambient temperature is likely to result in condensation of the flue gases, the vent pipe will be type ‘B’ vent or insulated with a suitable material as approved and specified by the insulation manufacturer to withstand temperature up to 460°F (238°C).

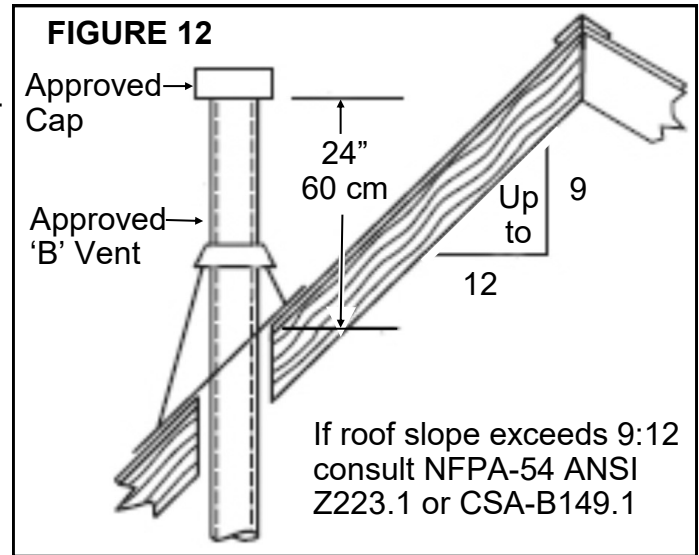

- Use an approved ‘B-vent’ termination cap as supplied by the manufacturer of the listed ‘B-vent’.

Minimum length of a vertical roof vent:

- Minimum 12 inch length (1 ft; 30 cm) single wall ‘C’ vent
- *Plus* one 90° “C” vent elbow
- *Plus* minimum 36 inch (3 ft; 92 cm) double wall ‘B’ vent
- Total minimum linear vent length of 48 inches (4 ft; 122 cm) *plus* one 90° ‘C’ elbow

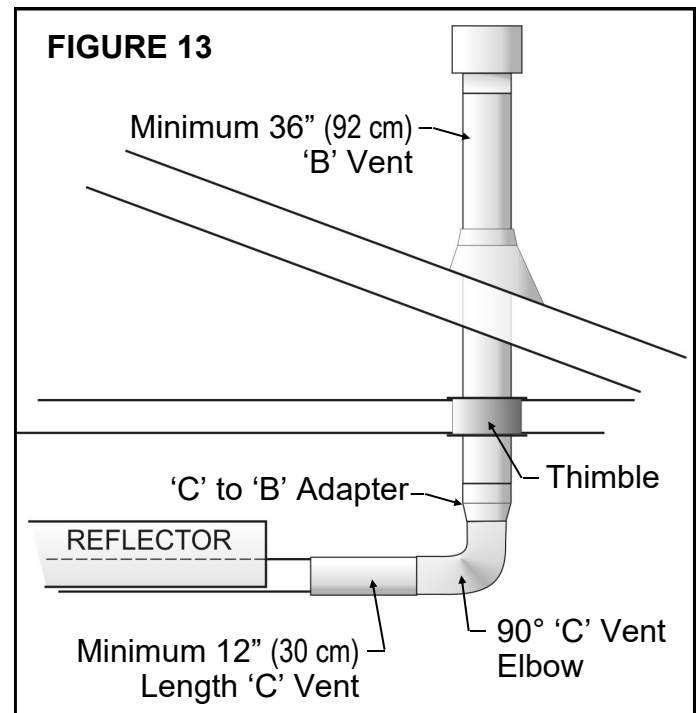

Maximum length of a vertical roof vent:

- Above minimum requirements must be met
- A maximum of one 90° elbow (equivalent 5 ft) *plus* two 45° elbows (each equivalent to 2.5 ft) can be installed in a vertical vent system
- Refer to local and national codes for maximum allowable venting

12 COMBUSTION AIR REQUIREMENTS



**Outside combustion air must not be ducted directly to this appliance.
Do not install a filter at the combustion air inlet.**

Make provision to ensure adequate combustion and ventilation air in the space:

- **USA:** In accordance with Section 9.3 ANSI Z223.1 / NFPA-54 for a fan-assisted appliance.
- **Canada:** In accordance with CSA B149.1: 4 in² (2,600 mm²) required free area of air-supply opening [acceptable round opening of approximate 2.25 in (57 mm) diameter].

Ensure adequate clearance around the air intake (at top of burner cabinet) to allow sufficient combustion air supply to the heater. Keep the area around the air intake free and clear of debris or other material.

Regularly check that the bird-screened air inlet on top of blower is not clogged with dust or fibrous material. Clean away any foreign matter build-up regularly.

13. GAS SUPPLY - GAS CONNECTION

CAUTION: It is the responsibility of the installer to ensure correct gas connection. Confirm local requirements for gas connection with local authority.

All gas supply piping and appliance connection must be in accordance with local and national codes, *ANSI Z223.1 (NFPA 54)* in the USA, and the *CSA B149.1 Natural Gas and Propane Installation Code* in Canada. Model P40-R is an appliance approved as a Vented Overhead Heater under ANSI Z21.86 / CSA 2.32 Vented Gas-Fired Space Heating Appliances.



TEST FOR LEAKS: All gas piping and connections must be tested for leaks after the installation is completed.

Apply soap suds solution to all connections and joints and if bubbles appear, a leak has been detected and must be corrected.



DO NOT USE A MATCH OR OPEN FLAME OF ANY KIND TO TEST FOR LEAKS. NEVER OPERATE THE HEATER WITH LEAKING CONNECTIONS.



Provide an 1/8 in (3.2 mm) NPT plugged tapping, accessible for test gauge connection, immediately upstream of the gas supply connection to the heater. The gas supply should be checked first with heater turned "OFF" followed by another check with heater turned "ON".

This appliance and its main gas valve must be disconnected from the gas supply piping system during any pressure testing of the gas supply piping system at test pressure in excess of 1/2 psi (3.5 kPa).



This appliance must be isolated from the piping system by closing the equipment shut off valve (field supplied) during any pressure testing of the gas piping system at test pressure equal to or less than 1/2 psi (3.5 kPa).

13. GAS SUPPLY - GAS CONNECTION ... continued



Provide a 1/8 in (3.2 mm) NPT plugged tapping, accessible for test gauge connection, immediately upstream of the gas supply connection to the heater. The gas supply should be checked first with heater turned "OFF" followed by another check with heater turned "ON".



This appliance and its main gas valve must be disconnected from the gas supply piping system during any pressure testing of the gas supply piping system at test pressure in excess of 1/2 psi (3.5 kPa).

This appliance must be isolated from the piping system by closing the equipment shut off valve (field supplied) during any pressure testing of the gas piping system at test pressure equal to or less than 1/2 psi (3.5 kPa).‡

IMPORTANT: Minimum supply line pressure at the inlet to the heater regulator must not be lower than 5.0 inches of water column pressure for natural gas, and not be lower than 10.0 inches of water column pressure for LPG. The supply gas pressure must be checked with all heaters in operation.

Installation of a gas line (trap) "drip leg" is required at the inlet connection tee following the pipe drop to the heater. Failure to provide a "drip leg" could result in condensation and foreign matter passing into the gas valve. Failure to install a "drip leg" in the gas line can cause property damage, injury or death and will void the heater warranty.

GAS TYPE	LINE PRESSURE INCHES WATER COLUMN		MANIFOLD PRESSURE (tap at gas valve outlet) INCHES WATER COLUMN
	MINIMUM	MAXIMUM	
Natural Gas	5.0	14.0	3.5
LP Gas	11.0	14.0	10.0

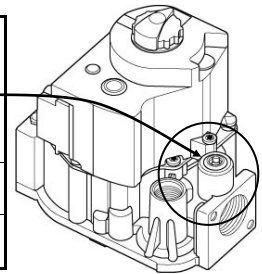

NOTE: Access to the manifold pressure test port is located on the top of the valve. A 3/16" Allen Key is required. A **manometer** should be used to check the manifold pressure. Gauges which measure in ounces or PSI are not accurate enough to measure or set the pressure.

GAS CONNECTION

Connection between the gas supply piping and the appliance must be in accordance with local and national codes, *ANSI Z223.1 (NFPA 54)* in the USA, and the *CSA B149.1 Natural Gas and Propane Installation Code* in Canada.

The P40-R is approved as a Vented Overhead Heater and may be rigid piped to the building gas supply (*also see Flexible Gas Connection Option, next page*). Check with local authority for locally required gas connection.

WHEN USING A FLEXIBLE GAS CON-

All gas pipe and fittings are field supplied.

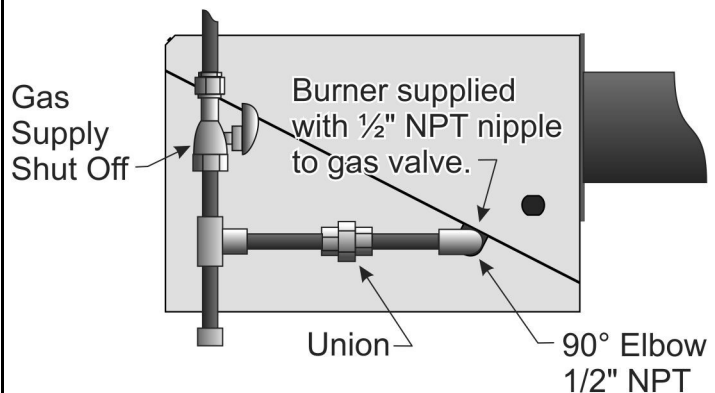

Provide a 1/8 in (3.2 mm) NPT plugged tapping, accessible for test gauge connection, immediately upstream of the gas supply connection to the heater

**SECTION TO THE APPLIANCE:
REQUIRED ORIENTATION OF FLEXIBLE GAS CONNECTOR**

It is the responsibility of the installer to ensure correct gas connection. Confirm local requirements for gas connection with local authority.

Where allowed or required by local code, a flexible gas connector may be used. Refer and adhere to local code requirements and NFPA 54 Section 9.6 (in the USA), and B149.1 Sections 4.1, 4.2, 4.3, and 6.21 (6.21.3(b)) in Canada.

If a flexible gas connector is used, it must be installed in the orientation shown in Figure 14 below as required by approval standards and national installation codes. This orientation protects the flexible gas connector from damage due to movement during heater expansion. Failure to install the gas connector in the proper orientation can result in a hazardous condition, property damage, personal injury or death.

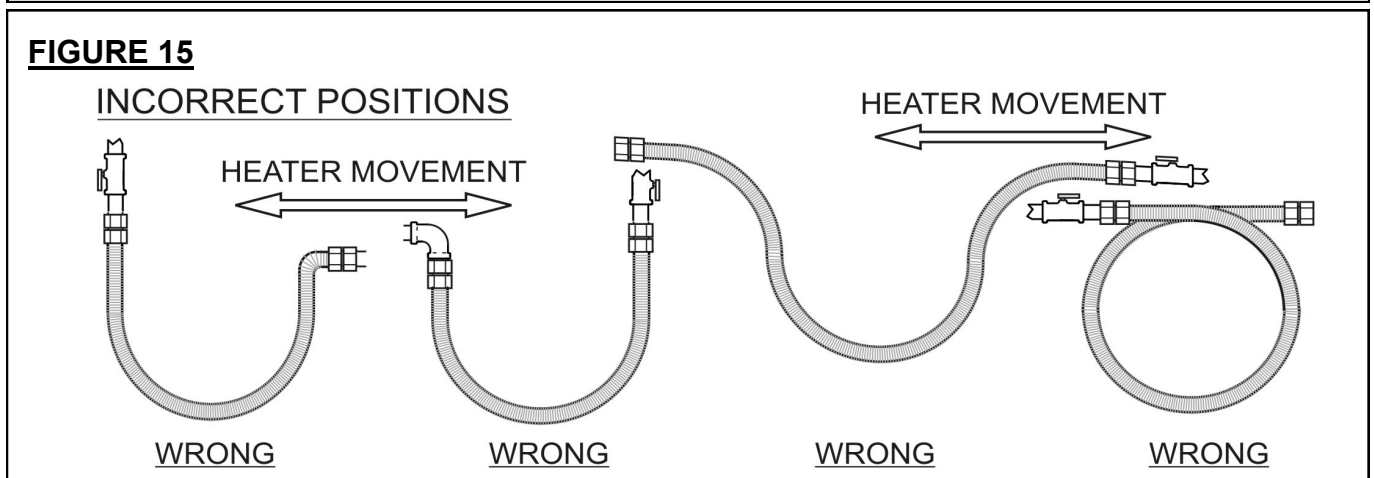
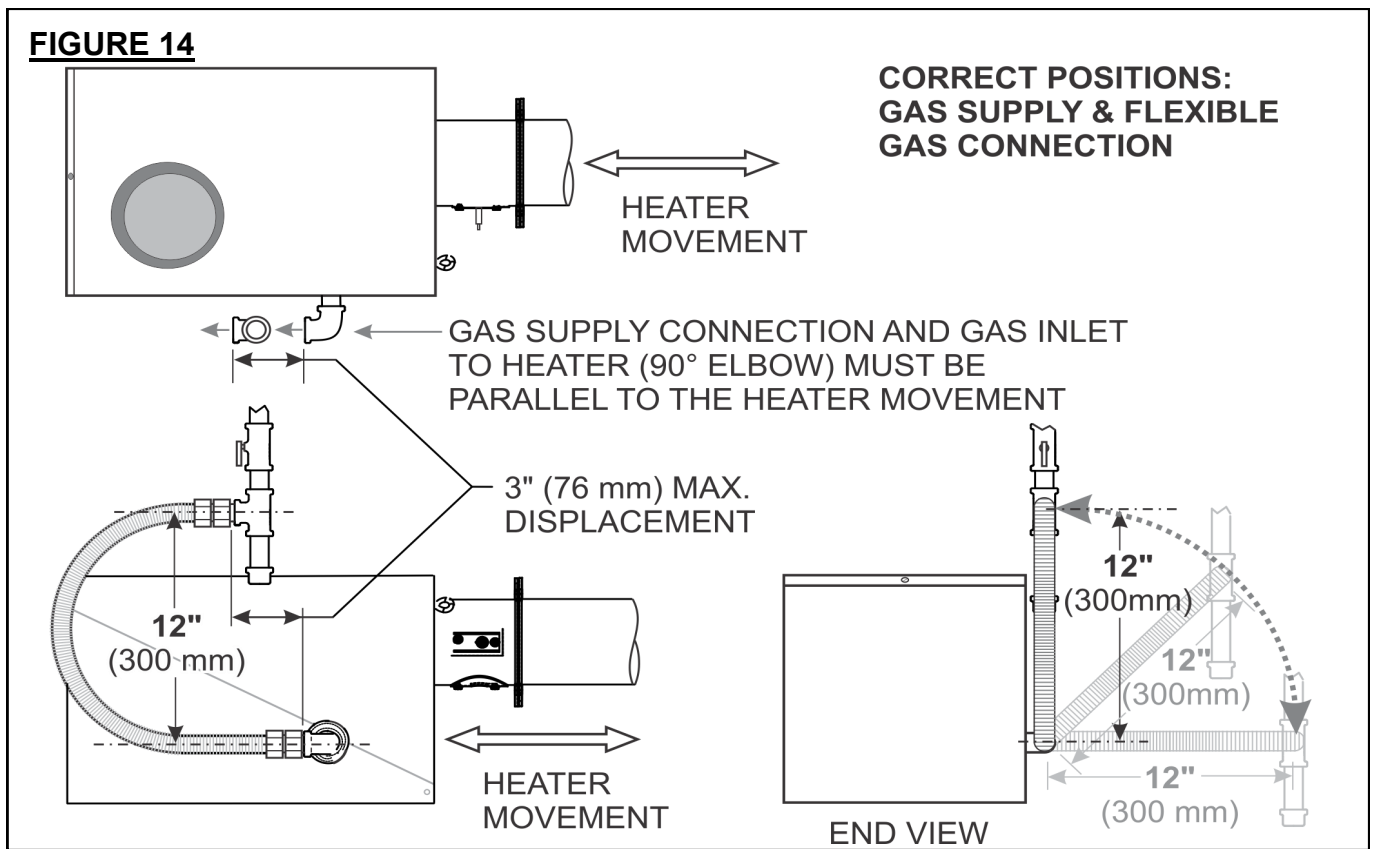

14. GAS CONVERSION



WARNING: Gas conversion must only be performed by a trained gas service technician.

Do not convert heater to alternate gas without using the proper kit listed below. Property damage, injury or death could result.

Standard production of this model heater is for use with natural gas. Field conversion between Natural Gas and Propane Gas must be accomplished using field conversion kits available from you local Schwank or InfraSave supplier:

- Part number: JS-0555-XA - Natural Gas to Propane Gas Conversion Kit P40-R
- Part number: JS-0555-XB - Propane Gas to Natural Gas Conversion Kit P40-R

15. ELECTRICAL AND THERMOSTAT WIRING (WIRING DIAGRAMS PAGE 29 & 30)



NOTICE

The heater must be electrically grounded in accordance with the National Electrical Code. ANSI / NFPA 70 or current Canadian Electrical code CSA C22.1.

Appliance and control wiring must be in accordance with all applicable local codes. The total load of all heaters must be considered in determining the required contact rating of the controlling thermostat or switch. Each tube heater requires 120V, 60 HZ electrical power sized for 145VA. Maximum power flow for internal 24V burner components is 21VA.

The ignition control includes a 24V/120V relay switch that provides a 45 second post-purge of the system. **A 24V Thermostat, TruTemp Thermostat, or 24V controller signal must be used for the post-purge feature to function.** A line voltage Thermostat or an "ON/OFF" switch will disable the post-purge feature.

A maximum night set-back of 9°F (5°C) is recommended for optimum economy and comfort. To maintain satisfactory comfort levels do not turn off the heating system over night/weekends.

16. HIGH ALTITUDE INSTALLATIONS - *also refer to chart in Section 26*

When installed above the altitude stipulated below for the USA or Canada, the input must be de-rated by 4% for each 1000 ft above the altitude listed . **If your local utility supplies gas with a de-rated heat content, no orifice change is required in the heater** . If the gas supply is not de-rated, the orifice must be changed according to the chart in Section 26. Check with your local utility regarding the gas supply and the de-rating of this appliance. Maintain gas supply pressures indicated in Table 4, page 25.

USA: The factory installed orifice for this appliance is approved for altitudes zero to 2000 feet above sea level. When installed above 2000 feet, **refer to Section 26.**

Canada: The factory installed orifice for this appliance is approved for altitudes zero to 4500 feet above sea level. When installed above 4500 feet, **refer to Section 26.**

17. LIGHTING INSTRUCTIONS

Refer to the lighting instructions label on the outside of the burner housing. If the unit locks out on safety, main power to the unit must be manually interrupted for a 30 second reset period before the heater can be restarted.

NOTE: On initial installation, the unit may lock out on safety owing to the length of time required to bleed air from the gas piping system.

18. RECOMMENDED MAINTENANCE



Improper adjustment, alteration, service or maintenance can cause property damage, injury or death. This heater must be installed and serviced only by a trained gas service technician.

At least annually inspect the entire heater system, venting, and gas supply connections prior to the heating season. Replace worn parts and repair deficiencies.

1. Periodically check the inlet air opening and the blower squirrel cage vanes, cleaning off any lint or foreign matter. It is important that the flow of combustion and ventilation air must not be obstructed.
2. Annually, prior to the heating season, lubricate the blower motor assembly by introducing several drops of oil to the top and bottom oil tubes located on the left hand side of the motor.
3. Periodically inspect the vent and vent termination to ensure no debris is blocking the vent, and that the integrity and construction of the vent piping is sound and no leakage is occurring.

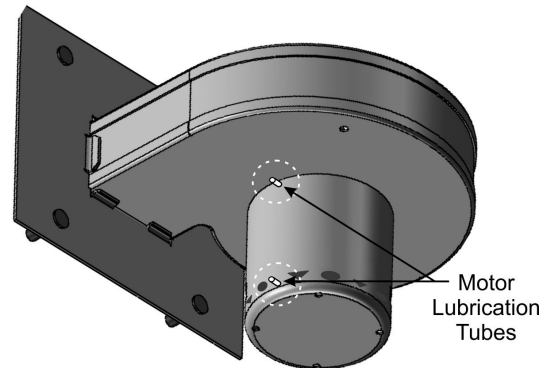

4. Visually inspect the burner flame periodically to ensure proper performance. The flame is visible through the sight glass assembly located on the bottom surface of the tube just downstream of the burner. The flame should be substantially blue - the occasional yellow fleck is normal. The flame should originate tight back to the burner cup face, and become cone shaped as it travels away from the burner cup. If the flame becomes yellow/orange, or if the flame is lifting away from the burner cup face, the burner requires cleaning or repair that must be conducted by a qualified gas service technician.

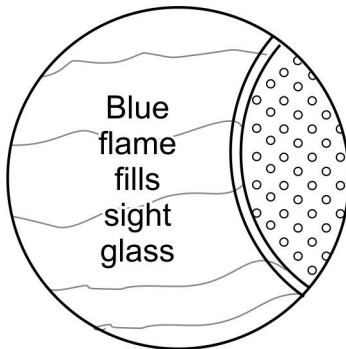

Correct Operation:
Blue flame fills
sight glass, tight
back to burner cup

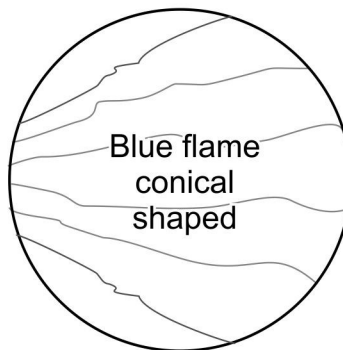

Correct Operation:
Blue flame becomes
cone shaped travelling
away from burner cup

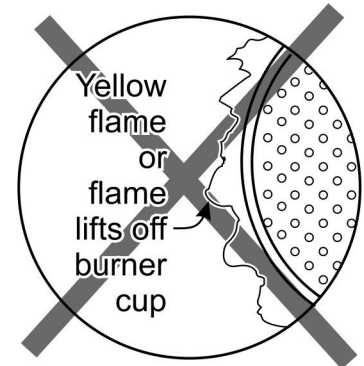

Incorrect Operation:
Yellow/orange flame or
blue flame lifts away
from burner cup.
Call service technician.

5. On an on-going basis, ensure that the area around the heater is kept clear and free from combustible materials, gasoline and other flammable liquids and vapors.
6. **CAUTION:** Label all wires prior to disconnection when servicing controls. Wiring errors can cause improper and dangerous operation.
7. Verify proper operation after servicing.

19. FENWAL DSI WIRING DIAGRAM: (HONEYWELL S87J - PAGE 30; CHANNEL MICRO 50N - PAGE 31)

24V OR 120 VOLT THERMOSTAT - SINGLE HEATER PER THERMOSTAT

NOTE: Heater must be controlled by 24Vac Thermostat to enable post-purge by the ignition control. Line voltage control disables the post-purge feature.

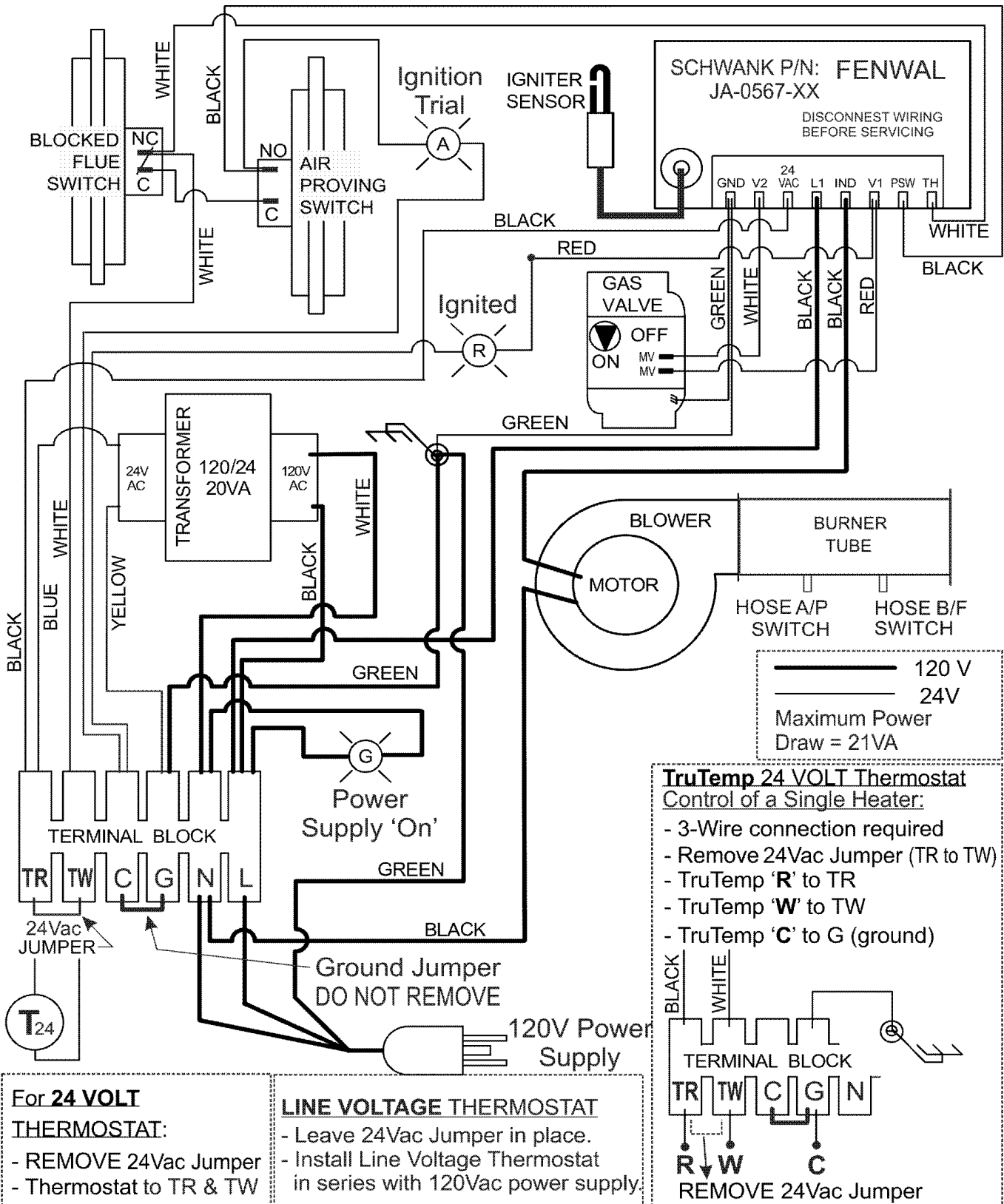

20. MULTIPLE TUBE HEATERS per THERMOSTAT: Fenwal DSI

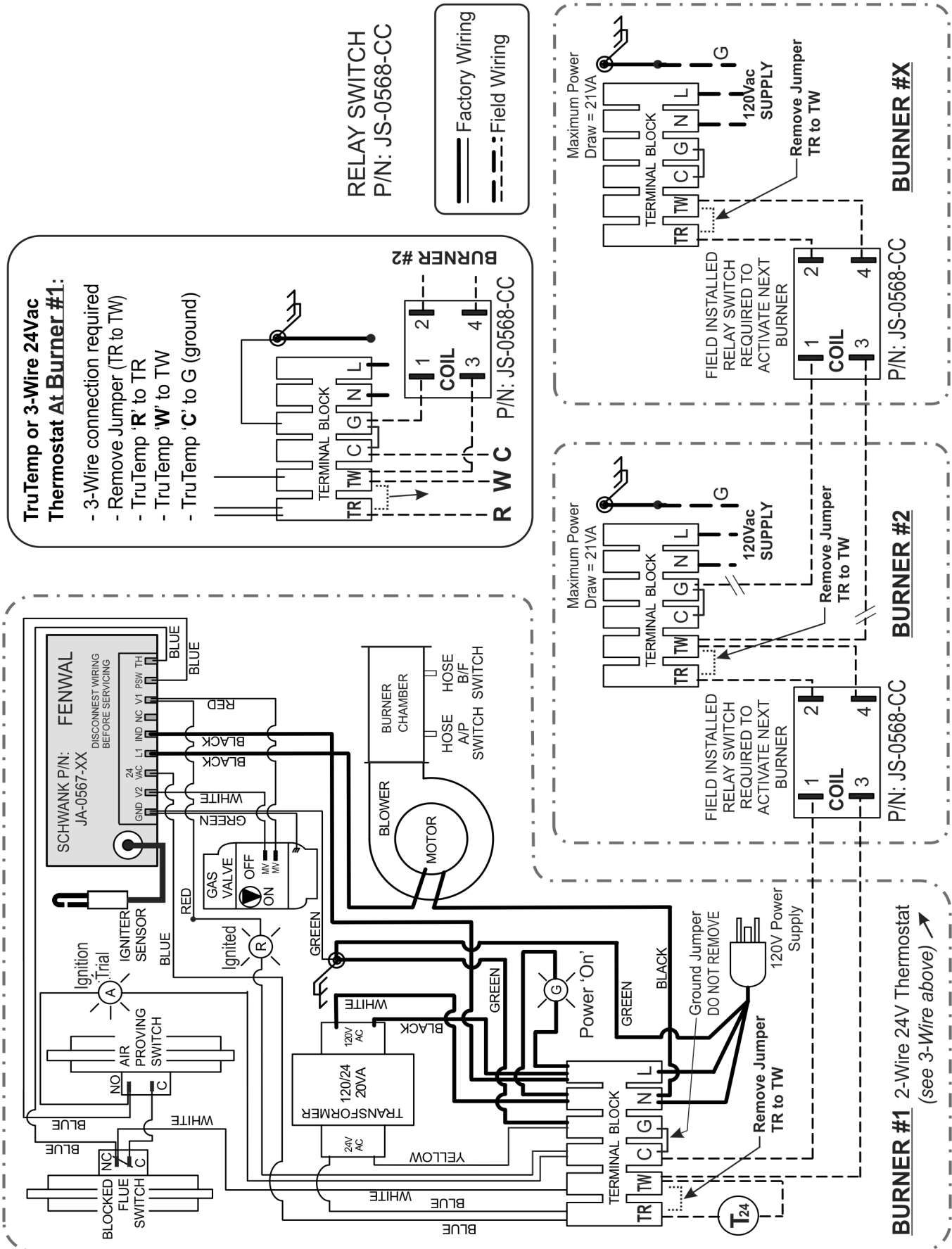

- Tru Temp or 3-Wire 24Vac Thermostat At Burner #1:**
- 3-Wire connection required
 - Remove Jumper (TR to TW)
 - Tru Temp 'R' to TR
 - Tru Temp 'W' to TW
 - Tru Temp 'C' to G (ground)

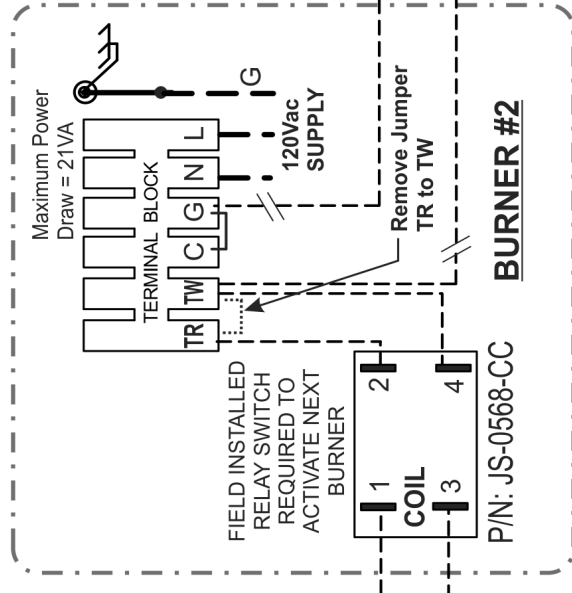
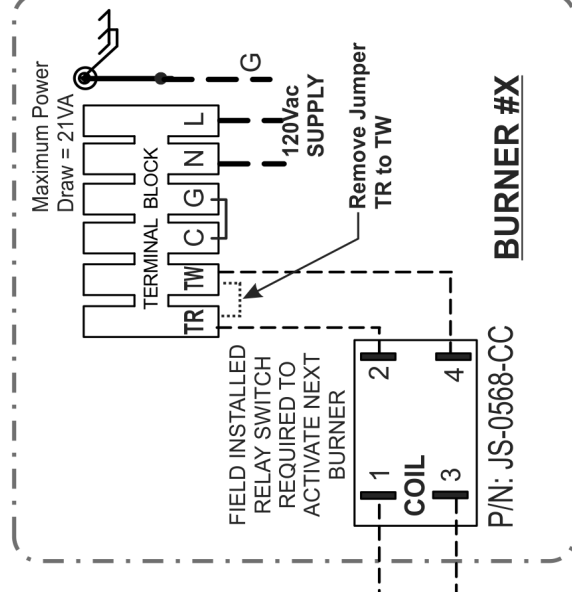
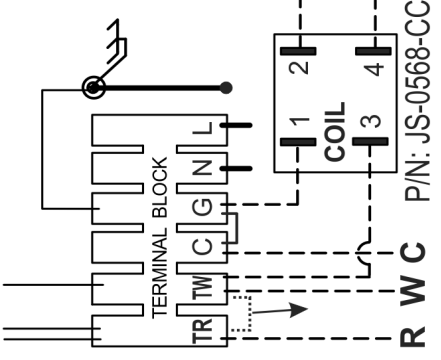

BURNER #1 2-Wire 24V Thermostat
(see 3-Wire above)

21. FENWAL DSI: SEQUENCE OF OPERATION / FLAME RECOVERY / SAFETY LOCKOUT

Power Up / Stand By

Upon applying 24 volts power to 24VAC, the control will reset, perform a self check routine, initiate full time flame sensing, flash the diagnostic LED for up to four seconds, and enter the thermostat scan state.

Heat Mode

When a call for heat is received from the thermostat supplying 24 volts to TH, the control checks the pressure switch for normally open contacts. The combustion blower is then energized and once the pressure switch contacts close, a 30 second purge delay begins. Following the purge period the gas valve is energized and spark commences for the 15 second trial for ignition.

When flame is detected during the trial for ignition, spark is shutoff immediately and the gas valve combustion blower remains energized. The thermostat, pressure switch, and main burner flame are constantly monitored to assure the system continues to operate properly. When the thermostat is satisfied and the demand for heat ends, the main valve is de-energized immediately, the control senses the loss of flame signal and initiates a 30 second post-purge period before de-energizing the combustion blower.

Failure to Light - Lockout (THREE TRIAL MODEL)

This three-try control will attempt two additional ignition trials with a 30 second inter-purge between trials, before going into 'soft' lockout. The valve relay will be de-energized immediately, and the combustion blower will be turned off following the 30 second post purge period.

If the thermostat continues to call for heat after one hour the control will automatically reset and attempt to ignite the burner again (three trials).

At any time less than the 1 hour auto-reset, recovery from lockout requires a manual reset by either resetting the thermostat or removing 24 volts for a period of 5 seconds.

Flame Failure - Re-Ignition

If the established flame signal is lost while the burner is operating, the control will respond within 0.8 seconds. The HV spark will be energized for a trial ignition period in an attempt to relight the burner. If the burner does not light the control will de-energize the gas valve. Two more attempts will be made to relight the burner. If the burner does not relight the control will go into 'soft' lockout as noted above in "Failure to Light". If flame is re-established, normal operation resumes.

Combustion Airflow Problems -Lockout

Combustion air flow is continually monitored during an ignition sequence by the air flow switch (PSW). If during the initial call for heat the pressure contacts are in the closed position for 30 seconds without an output to the Combustion Blower, an air flow fault will be declared and the control will remain in this mode with the combustion blower off.

If the air flow switch remains open for more than 30 seconds after the combustion blower output (L1 & IND) is energized, an air flow fault will be declared and the control will stay in this mode with the combustion blower on, waiting for the air flow switch to close.

When proper air flow is detected from the air flow switch input (PSW) the control begins the pre-purge period followed with a 15 second ignition sequence.

If the air flow signal is lost while the burner is firing, the control will immediately de-energize the gas valve and the combustion blower will remain on. If the call for heat remains, the control will wait for proper air flow to return. If proper air flow is not detected after 30 seconds an air flow fault signal will be declared. If proper air flow is detected at any time, a normal sequence will

Flame Fault

If at any time the main valve fails to close completely and maintains a flame, the full time flame sense circuit will detect it and energize the combustion blower. Should the main valve later close completely removing the flame signal, the combustion blower will power off following the optional post purge period.

Fault Conditions

The LED will flash on for 1/4 second, then off for 1/4 second during a fault condition. The pause between fault codes is 3 seconds.

Error Mode	LED Indication
Internal Control Failure	Steady on
Air Flow Fault	1 flash
Flame with No Call for heat	2 flashes
Ignition Lockout	3 flashes

MOUNTING AND WIRING

The Series 35-61 is not position sensitive and can be mounted vertically or horizontally. The case may be mounted on any surface with #6 sheet metal screws. All wiring must be done in accordance with local and national electrical code. Refer to wire diagram page 35 when connecting the Series 35-61 to other components in the burner.



WARNING

The Series 35-61 DSI Control uses voltages of shock hazard potential. Wiring and initial operation must be done by a qualified service technician. The control must be secured in an area that will experience a minimum of vibration and remain below the operating temperature of 160°F. All connections should be made with UL approved 105°C rated 18 gauge, stranded, .054 thick insulated wire. Refer to wire diagram page 35 when connecting the Series 35-61 to other components in the burner.

TERMINAL	SPADE	DESIGNATION
TH	1/4"	Thermostat Input
PSW	1/4"	Pressure Switch Input
V1	1/8"	Valve Power (MV)
IND	1/4"	Inducer Blower Output
NC	-	Alarm (Not used)
L1	1/4"	120/240 VAC Input (Hot)
24 VAC	1/4"	24 VAC Supply to Processor
V2	1/8"	Valve (MV)
GND	1/8"	Valve & System Ground
Spark	1/4"	Spark & Local Flame Sense

CAUTION:

Label all wires prior to disconnection when servicing controls. Wiring errors can cause improper and dangerous operation. A functional checkout of a replacement control is recommended.

PROPER ELECTRODE LOCATION

Proper location of the electrode assembly is important for optimum system performance. The electrode assembly should be located so that the spark gap is inside the flame envelope about 1 inch (2.5 cm) from the base of the flame at the burner cup.

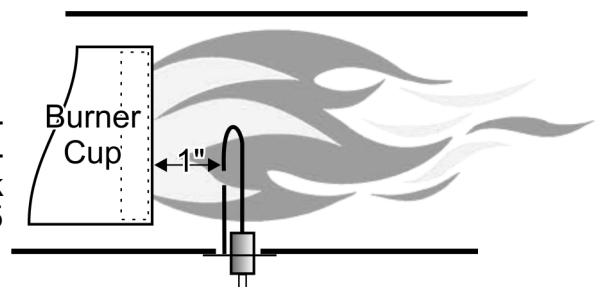

Electrodes should have a gap spacing of 3/16" (0.188" ± 0.031" or 4.76 mm ± 0.81 mm). If this spacing is not correct, the assembly must be adjusted or replaced. DO NOT adjust the curved igniter/sensor prong. Adjust/bend only the ground prong (**More Detail Page 32**).

SERVICE CHECKS

Flame current passes through the flame from the sensor to ground. The minimum flame current necessary to keep the system from lockout is 0.7 microamps. To measure flame current, connect an analog DC microammeter to the FC- FC+ terminals per figure at right.

Meter should read 0.7 μ A or higher. If the meter reads below "0" on analog scale, meter leads are reversed. Disconnect power and reconnect meter leads for proper polarity.

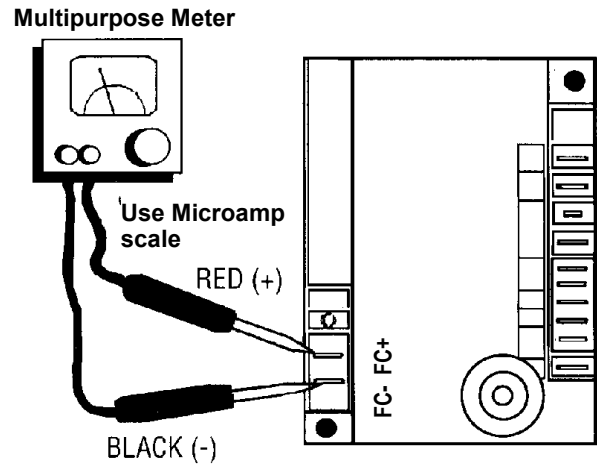

TROUBLESHOOTING - FENWAL DSI

(also see Heater Troubleshooting Page 38)

SYMPTOM	RECOMMENDED ACTION(S)
1. Dead	<ul style="list-style-type: none"> A. Miswired - check electrical supply (120Vac \pm 5%) B. Transformer bad (24Vac \pm 10%) C. Fuse/Circuit breaker bad D. Bad control (check LED for steady on)
2. Thermostat on - no blower output	<ul style="list-style-type: none"> A. Miswired B. Bad thermostat no voltage @ terminal W C. Bad control (check LED for steady on)
3. Pressure switch input okay, but no Trial-for-Ignition after purge delay	<ul style="list-style-type: none"> A. Miswired (check PSW terminal voltage: 24Vac \pm 10%) B. Flame sense problem (existing flame: check LED - 2 flashes) C. Bad control (check line voltage between L1 & IND)
4. Valve on, no spark	<ul style="list-style-type: none"> A. Shorted electrode B. Open HV cable C. Bad control
5. Spark on, no valve	<ul style="list-style-type: none"> A. Valve coil open B. Open valve wire C. Bad control (check 24Vac voltage between V1 & V2)
6. Flame ok during TFI, no flame sense (after TFI)	<ul style="list-style-type: none"> A. Bad electrode B. Bad HV igniter wire C. Poor ground at burner D. Poor flame (check flame current)

**22. HONEYWELL S87J DSI WIRING DIAGRAM:
24V OR 120 VOLT THERMOSTAT - SINGLE HEATER PER THERMOSTAT**

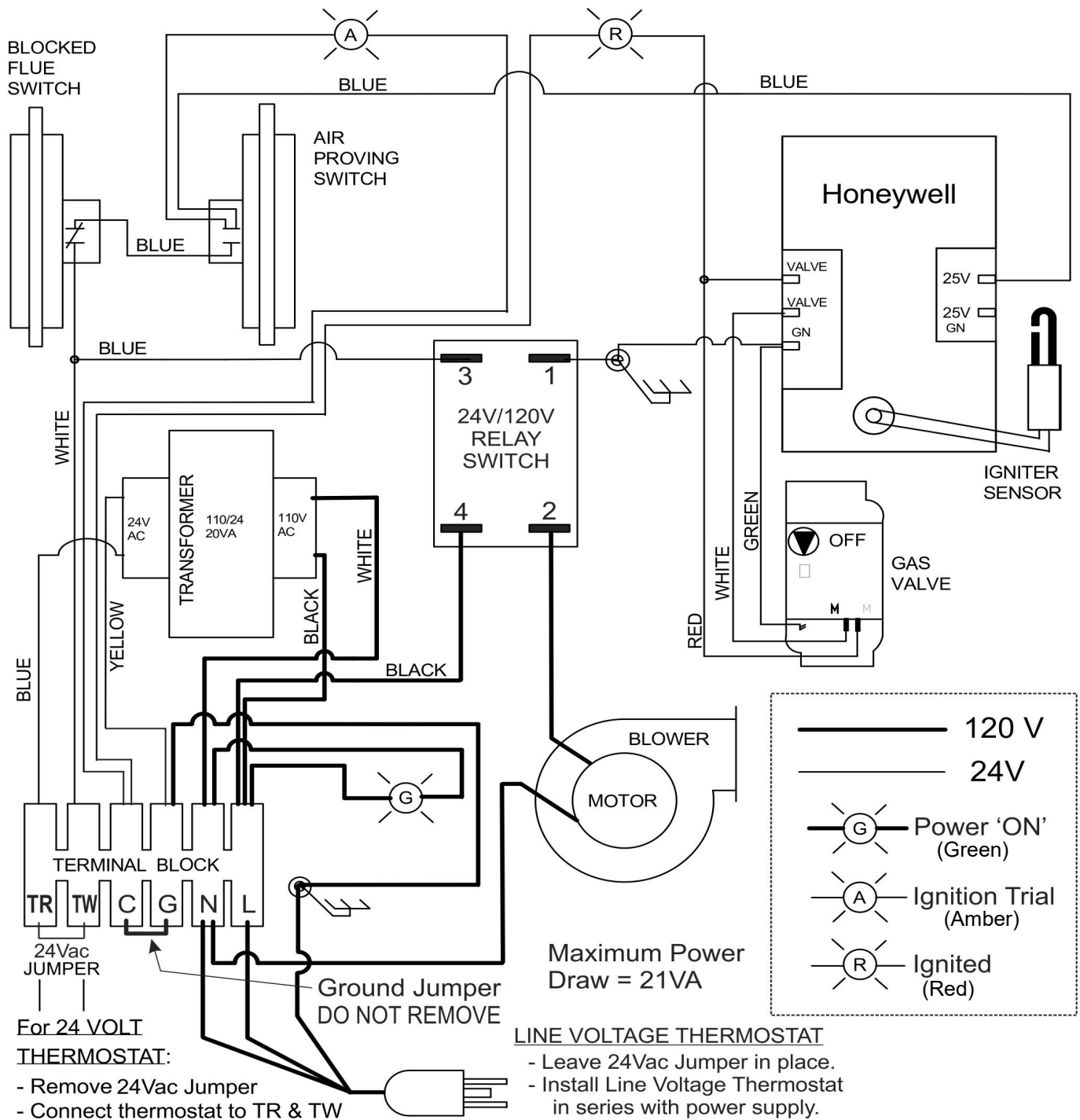

Each tube heater requires 120V, 60 HZ electrical power sized for 145VA. The heater includes a 24V/120V relay switch . Maximum power draw for internal 24V burner components is 21VA.

The heater must be electrically grounded in accordance with the National Electrical Code. AN-SI / NFPA 70 or current Canadian Electrical code CSA C22.1.

A maximum night set-back of 9°F (5°C) is recommended for optimum economy and comfort. To maintain satisfactory comfort levels do not turn off the heating system over night/weekends.

23. SEQUENCE OF OPERATION HONEYWELL S87J DSI CONTROL

The S87 ignition control module is powered by a 24Vac transformer and activated when the thermostat calls for heat. On every call for heat the S87J will delay start-up to provide a 30 second system pre-purge. When the S87 is activated by a thermostat or call for heat an internal transformer provides power to the electronic generator circuit for Spark Ignition and the safety lockout timing begins. At the same time, the S87 opens the gas controls main valve allowing gas to flow to the main Burner.

The S87 Control Module performs the following basic functions:

- Provides a 30 second system pre-purge
- Supplies power to the electronic pulse-generator circuit for the Spark Igniter (30,000 volts open circuit).
- Allows 21 seconds for Ignition trial (TFI) before system safety lockout occurs.
- Senses the Burner flame for safe lighting
- Shuts off the spark after the Burner is lit.

Burner with direct spark ignition, sequence is as follows :

- 1a. **Line Voltage Thermostat:** Upon a call for heat by the line voltage Thermostat or “ON/OFF” switch, the Blower and the 120/24 volt Transformer are powered simultaneously with 115 volts.
- 1b. **24 Volt Thermostat:** The 120 volt supply to heater will power the 120v/24v Transformer and the 120V side of the Blower switching relay simultaneously. A call for heat by the 24 volt Thermostat energizes the 24 volt control circuit and the 24v/120 volt relay powering the Blower.
2. The 24 volt control circuit powers the DSI control in series through the normally open Air Pressure Switch (APS) and the normally closed Blocked Flue Switch (BFS).
3. The Blower creates a positive pressure and closes a normally open contact inside the Air Proving Switch (APS).
4. 24 volts supplied to the DSI control initiates the 30 second pre-purge cycle.
5. After completing the 30 second pre-purge cycle the DSI control generates high voltage to the Spark Igniter, and 24 volts to energize the Gas Valve.
6. The Burner will light and establish a steady flame.
7. Once the flame sensor determines there is a steady flame established, with a minimum flame signal of 1.5 μ A the spark igniter is then de-energized.
8. In the event ignition does not occur, the safety circuit will function to interrupt gas flow after approximately 21 seconds and lock the system out. No further gas will flow until the power has been manually interrupted for a period of 30 seconds. This will reset the ignition module and the operating sequence will restart at step #1
9. If the blower does not run, the blower air pressure switch (normally open contact) does not close and power is not supplied to the ignition control.

FLAME SENSING CIRCUIT - HONEYWELL S87 DSI

The output of the flame sensing circuit cannot be checked directly on the S87 body. Check the flame sensing circuit directly by checking the flame sensing current from the sensor to the S87 as follows.

1. Connect a meter (dc microammeter scale) in series with the flame signal ground wire as shown below. Using the Honeywell W136A Test Meter or equivalent. Disconnect the ground wire from the S87. Connect the red (positive) meter lead to the free end of the ground wire. Connect the black (negative) meter lead to the quick-connect ground terminal on the S87.
2. Restart the system and read the meter. The flame sensor current must be at least 1.5 μA and steady. If the reading is less than 1.5 μA or unsteady, see LOW OR UNSTEADY FLAME CURRENT section, below.

If a flame is present at sensor and a reading of zero μA is obtained, check for a secondary ground connection to the 24V (GND) terminal. If secondary connection exists, temporarily remove connection and measure flame current.

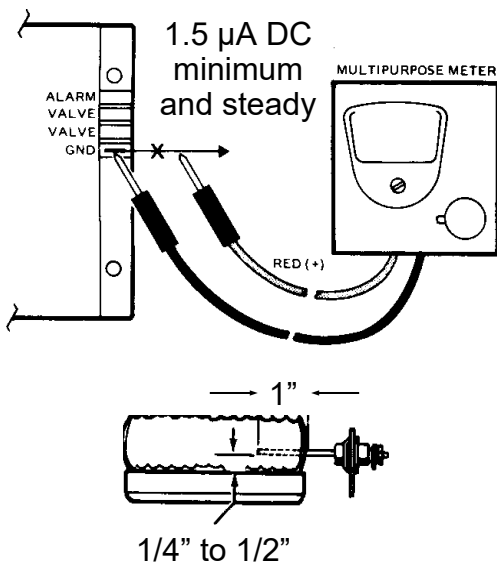

A good rectifying flame is achieved with approx 1" of sensor in a strong blue flame, positioned 1/4" to 1/2" away from flame source surface.



A lazy or weak flame is not a good rectifying flame. Check gas pressure and gas orifice for insects, and spider webs.

LOW/ UNSTEADY FLAME CURRENT

If the current to the S87 flame circuit is less than 1.5 μA or is unsteady, check the burner flame, flame sensor location and electrical connections as follows.

Electrical Connections and Shorts

Connections at the flame sensor must be clean and secure. If wiring needs replacement, use moisture resistant #18 wire rated for continuous duty up to 221^o F [105^o C].

Flame Sensor

The flame signal is best when about 1 in. [25 mm] of flame rod is immersed in the burner flame. A bent flame rod, bent mounting bracket or cracked ceramic insulator will affect flame signal.

Replace flame sensor if necessary.

Burner Flame

The flame sensor must be constantly immersed in flame. Check burner flame condition as shown opposite. Observe burner rating plate for the correct gas pressure, and check with a manometer. If gas pressure is correct check line and orifice for obstructions.

**24. CHANNEL MICRO 50N DSI WIRING DIAGRAM:
24V OR 120 VOLT THERMOSTAT - SINGLE HEATER PER THERMOSTAT**

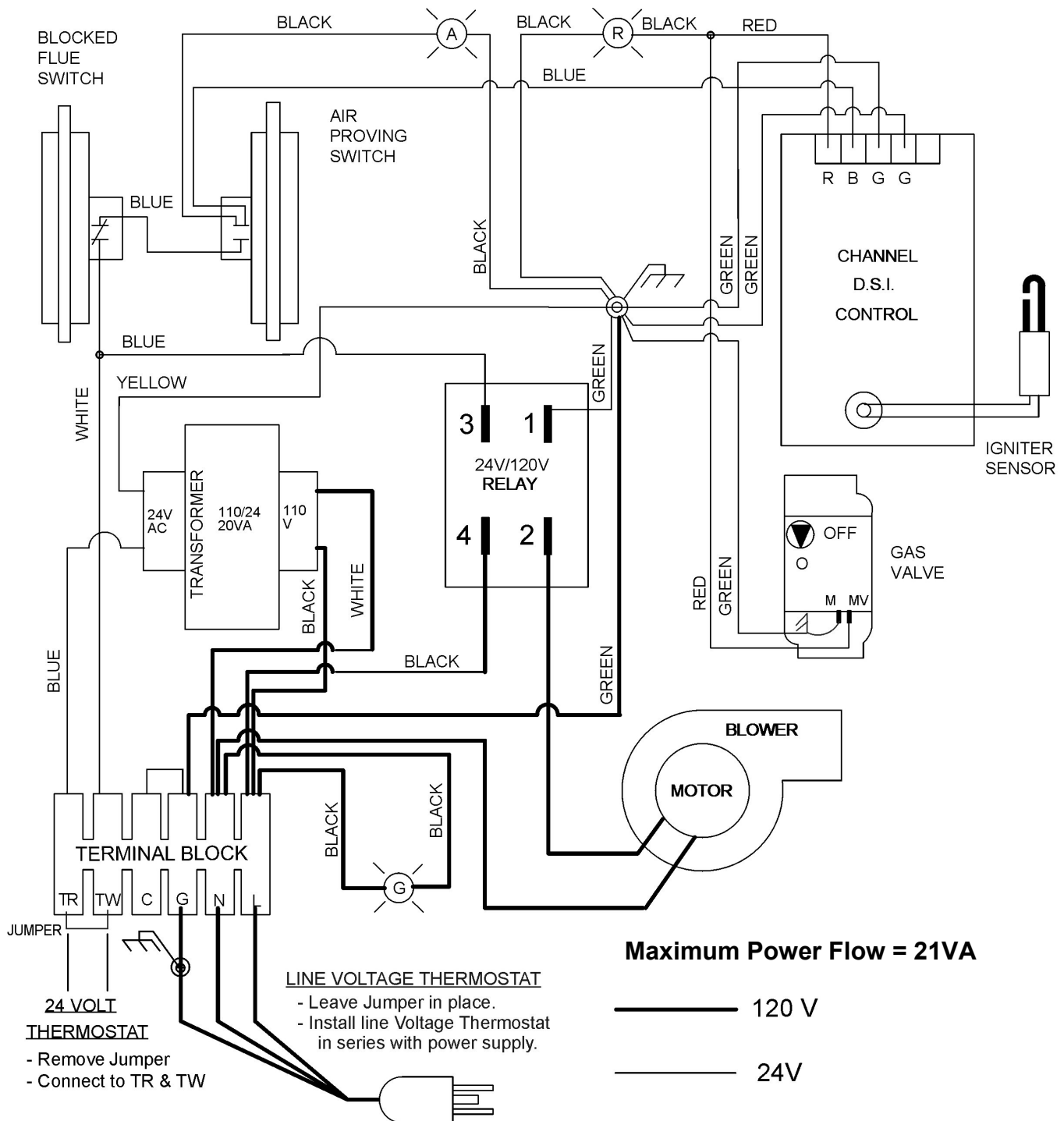

Each tube heater requires 120V, 60 HZ electrical power sized for 145VA. The heater includes a 24V/120V relay switch. Maximum power draw for internal 24V burner components is 21VA.

The heater must be electrically grounded in accordance with the National Electrical Code. AN-SI / NFPA 70 or current Canadian Electrical code CSA C22.1.

A maximum night set-back of 9°F (5°C) is recommended for optimum economy and comfort. To maintain satisfactory comfort levels do not turn off the heating system over night/weekends.

25. SEQUENCE OF OPERATION GASLITER MICRO 50N DIRECT SPARK IGNITION (DSI)

The MICRO 50N is a three trial ignition control module with a 30 minute soft lockout/reset. It is powered through a safety control circuit by a 24v transformer that is activated when the thermostat calls for heat. On every call for heat the MICRO 50N will delay start-up with a 30 second system pre-purge. After pre-purge an electronic generator powers the spark igniter and retrial/safety lockout timing begins. At the same time, the gas control valve is opened allowing gas to flow to the burner.

The MICRO 50N Control Module performs the following basic functions:

- Provides a 30 second system pre-purge
- Supplies power to the electronic pulse-generator circuit for the spark igniter (30,000 volts open circuit).
- Allows up to three 20 second trials for ignition before a 'soft' system safety lockout of 30 minutes occurs.
- Three time trial for ignition and soft 30 minute lockout repeat
- Senses the burner flame for flame maintenance
- Shuts off the spark sequence after flame is established

Burner operation sequence:

- 1a. **Line Voltage Thermostat:** A call for heat by the line voltage Thermostat or an "ON/OFF" switch, powers the blower and 120/24 volt Transformer simultaneously ... *continue to 2.*
- 1b. **24 Volt Thermostat:** *NOTE: A 24Vac thermostat can control only a single heater using the 120/24V transformer in the burner as the 24Vac source of power to the thermostat. Multiple heaters per 24Vac thermostat require optional Control Center JM-0303-KT (see page 39).*

The 120 Vac supply to the burner simultaneously provides power to a 120/24V transformer and the 120V terminal of a relay switch (open). When the 24 Vac thermostat calls for heat the coil of the 24/120 volt relay switch is energized and closes 120Vac to the blower.
2. 24 Vac is provided to the proving air switch. The blower air supply creates a positive pressure and closes the normally open proving air switch, closing 24 Vac to the normally closed blocked flue switch.
3. Provided there is no blockage in the system (tube and vent), the blocked flue switch remains in a normally closed position.
5. 24 Vac is supplied to the DSI control and the 30 second pre-purge cycle is initiated.
6. After completing the 30 second pre-purge cycle, the DSI control generates high voltage to the spark igniter, and 24 Vac to energize the Gas Valve.
7. The burner ignites and establishes a steady flame.
8. Once the flame sensor (part of the spark igniter) determines there is a steady flame established, with a minimum flame signal of 1.5 μ A to the control, ignition spark is de-energized.
9. In the event ignition does not occur, the DSI control will retry the ignition sequence up to an additional two trials. If ignition does not occur after the third ignition trial, the system will enter a 30 minute 'soft' lock-out. This will reset the ignition module and the operating sequence will restart at step #1 after the 30 minute soft lock-out period.
10. If there is a loss of flame during the run mode, the unit will energize the spark within 0.8 seconds and perform a trial for ignition without the gas valve being closed first (Spark Restoration). If a flame is not established during Spark Restoration the unit will repeat the process in step number 9 (above).

GASLITER MICRO 50N IGNITION CONTROL

The MICRO 50N is a microprocessor-based DSI (Direct Spark Ignition) control which continuously monitors the entire system to ensure safe operation under all conditions.

Features of the MICRO 50N DSI Control include 30 second purge and 20 second ignition trial, with three ignition attempts, a diagnostic alarm output, automatic recycle on lockout (soft lockout).

SPECIFICATIONS

Operating Voltage:	24 VAC, 50/60Hz
Power Consumption:	200mA maximum, exclusive of valve/alarm loads
High Voltage:	15kV minimum with 50 pF load
Spark Gap:	3/16" [4.8 mm]; 0.150 inches +/- 0.050 inches [3.8 mm +/- 1.2 mm]
Spark Rate:	60 sparks per second
Gas Valve Output:	2A maximum
Alarm Output:	2A maximum, dependent on optional alarm type
Operating Temperature:	-40°F to +185°F (-40°C to +85°C)
Environmental Protection:	Polyurethane encapsulated units pass 500 hour salt spray test to ASTM 117
Mating Connectors: 6 Pin:	MOLEX 08-50-8063 or equivalent

NORMAL OPERATING SEQUENCE

Power up / Pre-purge

When powered up, the unit performs a series of diagnostic checks to determine if the system is in working order.

Trial for Ignition

After a pre-purge, the unit will power the valve solenoid and begin a trial for ignition. The spark will be enabled for the first 80% of the trial period and then suppressed for the last 20% of the trial period to allow the unit to sense weak flame signals.

Run

When a flame is sensed, the unit suppresses the spark and keeps the valve powered. Power is removed from the unit when the thermostat is satisfied.

ABNORMAL CONDITION OPERATING SEQUENCE

No Flame Established - Soft Lockout Mode

If a flame is not established during the trial for ignition, the unit will perform an inter-purge and retriial for ignition. This protocol is followed for the number of tries specified. If a flame is not established during the final ignition attempt, the unit will enter the soft lockout mode, which includes a reset delay before another normal trial for ignition series begins.

Loss of Flame - Spark Restoration Retrial

If there is a loss of flame during the run mode, the unit will energize the spark within 0.8 seconds and perform a spark restoration trial for ignition. In this mode, the ignition means is restored without the gas valve being closed. If a flame is not established during the restoration trial, the unit will perform as in "No Flame Established" fault operation above.

Leaking Valve - Hard Lockout Mode

If a flame is present when the gas valve is not energized, the unit will enter the hard lockout mode.

Internal Fault - Hard Lockout Mode

If an internal fault is detected within the unit, the unit will enter the hard lockout mode.

System or External Fault - Hard Lockout Mode

If the unit detects a system fault or an external fault, the unit enters the hard lockout mode.

26. SPARK IGNITION CIRCUIT

The step-up transformer in the ignition control provides spark ignition at 30,000 volts (open circuit). To check the spark ignition circuit, proceed as follows.

- Shut off gas supply to the gas control
- Disconnect the ignition cable at the ignition control stud terminal to isolate the circuit from the Spark Igniter or Igniter / Sensor
- Prepare a short jumper lead, using heavily insulated wire such as ignition cable



CAUTION

In the next step, **DO NOT** allow fingers to touch either the stripped end of the jumper or the stud terminal. This is a very high voltage circuit and electrical shock, personal injury, or death can result.

- Perform this test immediately upon energizing the system before the Ignition Control goes into safety lockout and interrupts the spark circuit. Touch one end of the jumper firmly to the ignition control GND terminal. (DO NOT remove the existing ground lead.) Slowly move the other end of the jumper wire toward the stud terminal on the Ignition Control to establish a spark.
- Pull the wire away from the stud and note the length of gap at which spark discontinues.
- A spark length of 1/8 in. (3 mm) or more indicates satisfactory voltage output. If no arc can be established, or the maximum spark is less than 1/8 in. (3 mm), and power to the Ignition Control input terminals was proved, replace the Ignition Control.

TURN OFF THE POWER AND RECONNECT THE IGNITION WIRE TO THE IGNITION CONTROL STUD. DISCONNECT THE IGNITION WIRE FROM THE IGNITER AND REPEAT THE STEPS ABOVE BY GROUNDING THE WIRE OUT TO THE TUBE BODY THIS TIME. TURN ON THE POWER AND PULL THE WIRE AWAY FROM THE TUBE AND NOTE THE LENGTH OF GAP AT WHICH THE SPARK DISCONTINUES. IF THERE IS NO SPARK OR WEAK SPARK REPLACE THE IGNITION WIRE.

27. SPARK IGNITER ADJUSTMENT

Use the following diagram to check the Igniter gap. If the gap is incorrect all adjustments should be made with the **GROUND PRONG/PIN ONLY!** **DO NOT BEND THE IGNITER PRONG!!!!**

USE THE BLACK BARS BELOW AS A GUIDE FOR ADJUSTMENT. USE THE BARS THAT COINCIDE WITH THE FORMAT & SIZE OF THIS PUBLICATION.

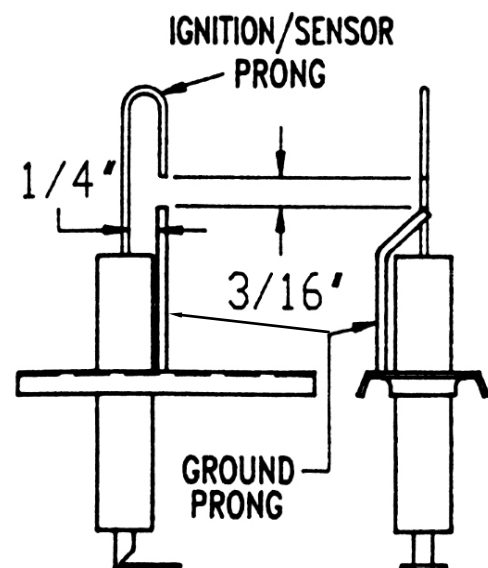
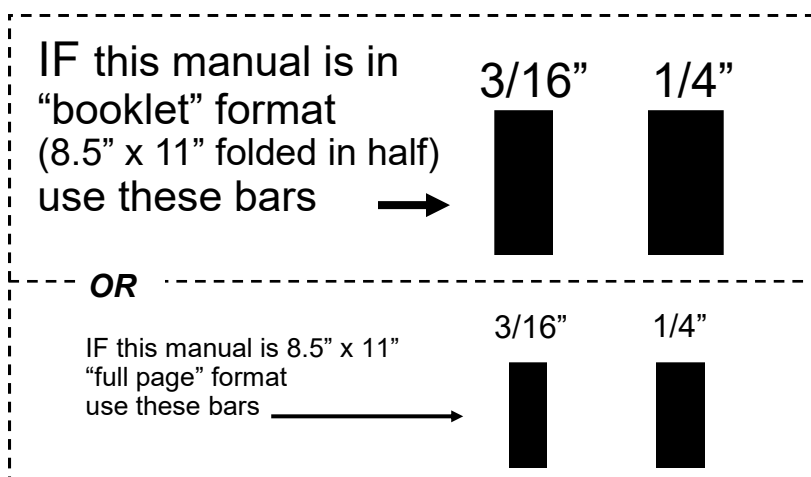

28. TROUBLESHOOTING GUIDE



WARNING

Improper adjustment, alteration, service or maintenance can cause property damage, injury or death. This heater must be installed and serviced only by a trained gas service technician.

SEQUENCE OF EVENTS

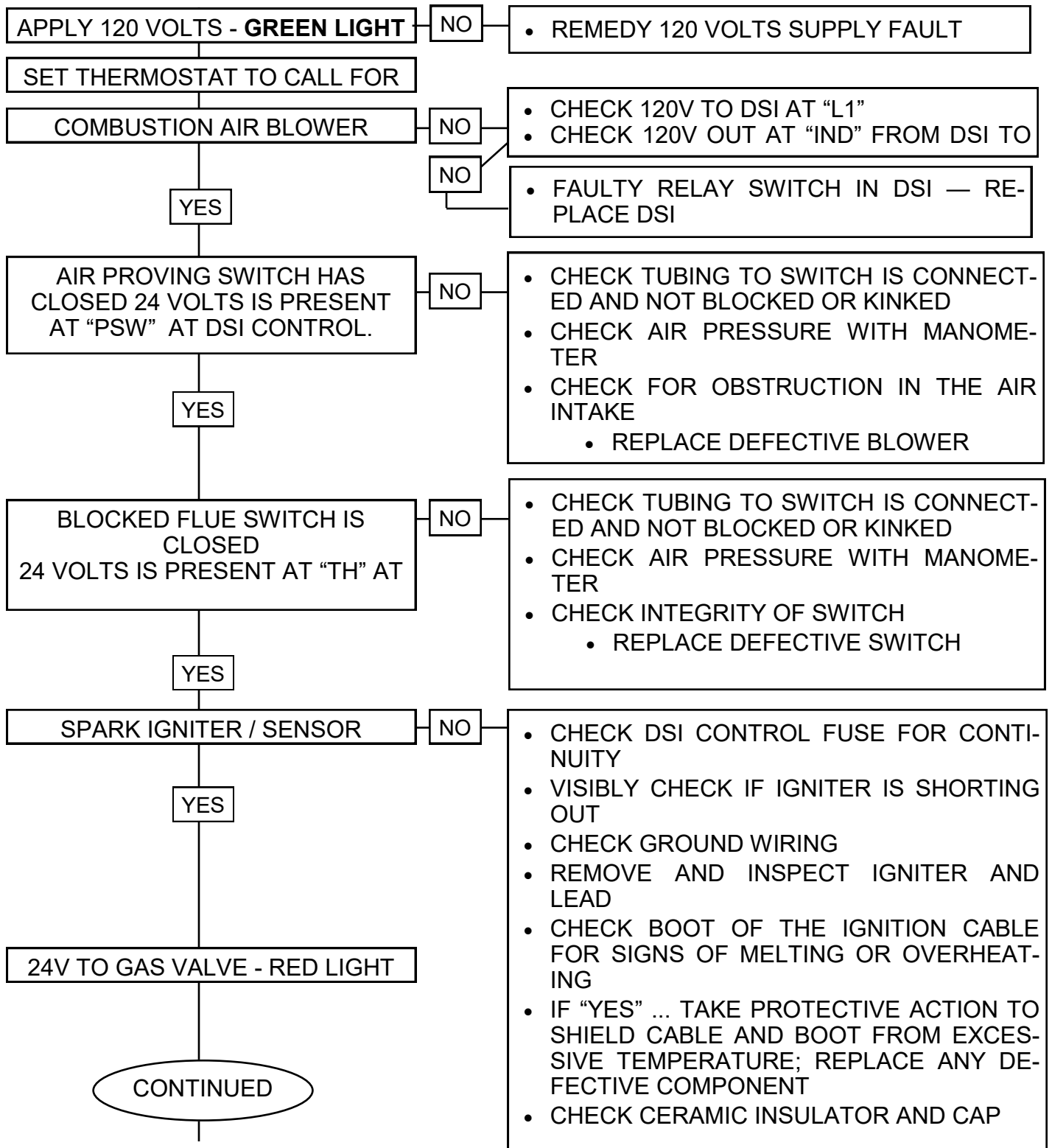

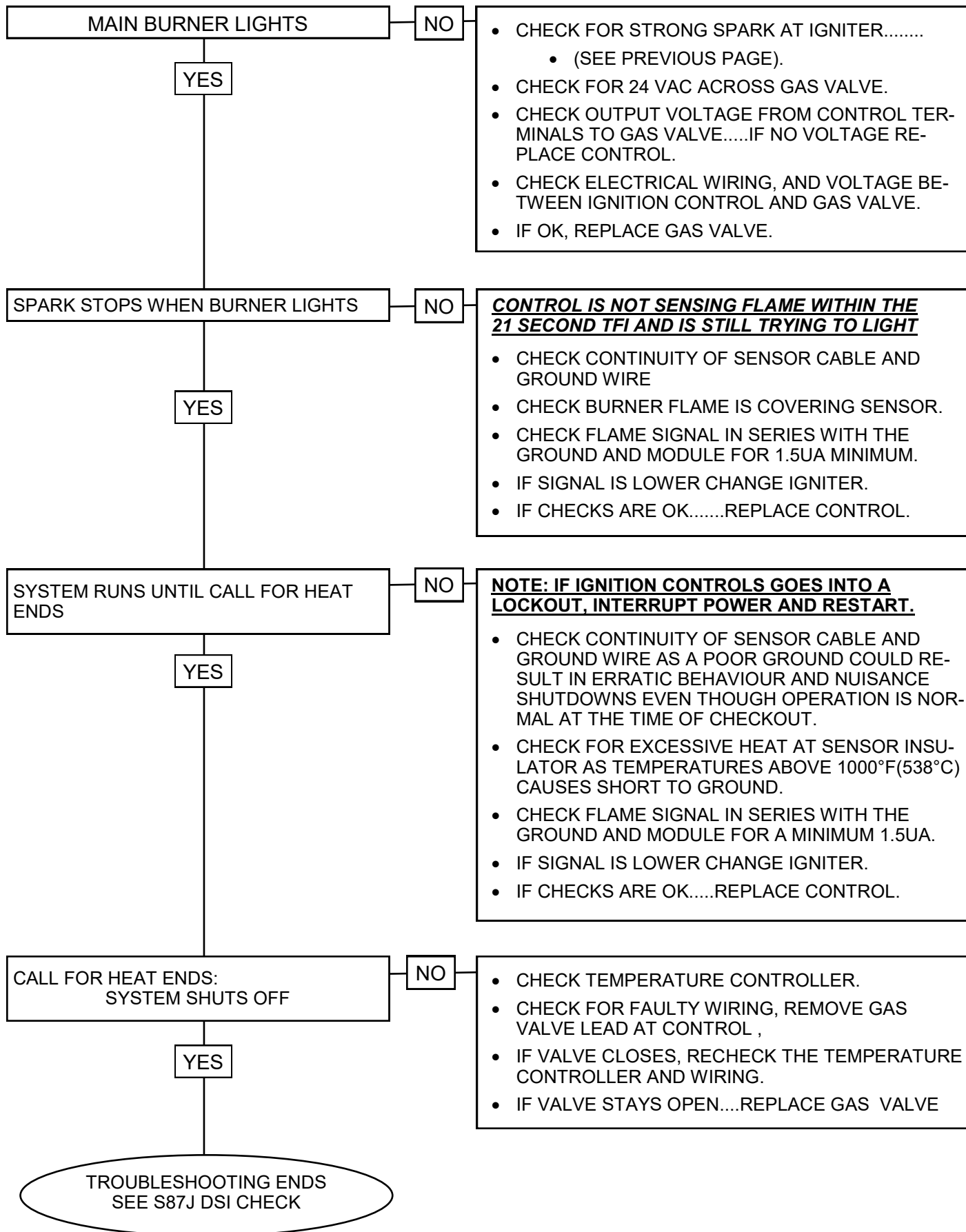

29. START-UP / COMMISSIONING SHEET



THIS EQUIPMENT HAS BEEN FACTORY FIRED AND TESTED PRIOR TO SHIPMENT. HOWEVER, THIS APPLIANCE IS NOT “PLUG & PLAY”. IT REQUIRES COMMISSIONING AND FIELD ADJUSTMENT / SPECIFICATIONS CONFIRMATION TO ENSURE SAFE AND EFFICIENT OPERATION.

**COMMISSIONING REPORT
AS PER I&O MANUAL AND LOCAL CODES**

CONTRACTOR NAME:DATE.....

ADDRESS:.....
.....

CITY:.....

PHONE:.....

CELL:

JOB SITE.....CITY.....

HEATER MODEL NUMBER:.....
Located on burner rating plate

HEATER SERIAL NUMBER:

TO ENSURE THAT SITE CONDITIONS ARE COMPATIBLE WITH THE HEATER’S PERFORMANCE AND TO ALLEVIATE NUISANCE CALL-BACKS, THE FOLLOWING START-UP NEEDS TO BE COMPLETED BY THE QUALIFIED GAS INSTALLER.

A TECHNICIAN CALLING FOR TECHNICAL SUPPORT MUST PROVIDE THE INFORMATION FROM THE COMPLETED COMMISSIONING REPORT ON THE NEXT PAGE

**FAX COMPLETED REPORT TO TECHNICAL SERVICES:
FAX 1-866-361-0523,
VOICE 1-877-446-3727**



WARNING

START UP ‘SMOKE’

During start up, material coatings used in the production process of tubes and reflectors will “burn off” and create smoke during the first hour of operation. This is temporary and normal. Please ensure that there is sufficient ventilation to adequately clear the smoke from the space. Notify site and safety personnel to ensure that alarm systems are not unduly activated.

**QUALIFIED INSTALLER TO COMPLETE THIS
TUBE HEATER COMMISSIONING REPORT**

TYPE OF GAS: NG LP

DOES BUILDING HAVE A NEGATIVE CONDITION: YES NO

IF THIS IS A HIGH ALTITUDE AREA WHAT IS THE ALTITUDE ABOVE SEA LEVEL Ft

DOES APPLICATION REQUIRE FRESH AIR TO BURNER YES NO

IS HEATER EXPOSED TO CHEMICAL OR CORROSIVE ATMOSPHERE: YES NO

ARE ACTUAL MINIMUM CLEARANCES AS PER TABLE 3 YES NO

CAN HEATER BE AFFECTED BY OVERHEAD CRANES / VIBRATION YES NO

ARE GAS SUPPLY LINES ADEQUATELY SIZED FOR SYSTEM YES NO

GAS LINES AND BRANCHES HAVE BEEN PURGED OF AIR: YES NO

THIS HEATER FIRED WITHOUT ANY MALFUNCTION: YES NO

INLET GAS SUPPLY PRESSURE WITH HEATER OPERATING : WC"

GAS VALVE OUTLET (Manifold) PRESSURE WITH HEATER OPERATING: WC"

WHAT IS THE LINE VOLTAGE READING AT THE HEATER VOLTS

WHAT IS THE VOLTAGE READING AT THE IGNITION MODULE VOLTS

WHAT IS THE FLAME SIGNAL STRENGTH IN uA FROM SENSOR: uA (microamps)

IS HEATER CONTROLLED BY A THERMOSTAT YES NO

IS THE THERMOSTAT STRATEGICALLY LOCATED YES NO

WHAT IS TOTAL LENGTH OF INSTALLED THERMOSTAT WIRE FEET

WHAT IS THE GAUGE OF THE THERMOSTAT WIRE GAUGE

WHAT IS THE HEATER TUBE LENGTH (10ft per Tube section) FEET

WHAT IS THE TOTAL LENGTH OF THE VENT (add 10ft for each bend) FEET

WHAT LENGTH IS COMBUSTION AIR INTAKE (add 10ft for each bend) FEET

IF REQUIRED....WHAT IS THE LENGTH OF THE TURBULATOR(S) FEET

IF INSTALLED....IS TURBULATOR AT FLUE END OF SYSTEM YES NO

"MAXIMUM STACKING HEIGHT" SIGN(S) - POSTED AT THERMOSTAT(S)

THIS HEATER MUST BE ELECTRICALLY GOUNDED

FAX COMPLETED REPORT TO TECHNICAL SERVICES: FAX 1-866-361-0523, VOICE 1-877-446-3727

30. DIMENSIONS AND WEIGHT

Assembled System:

- Weight: 96 pounds (44 kg)
- Dimensions: 119.5" L x 20" W x 12" H (3035 mm x 508 mm x 305 mm)

Burner:

- Weight: 26 pounds (11.8 kg)
- Dimensions: 16" L x 10.25" W x 10.75" H (406 mm x 260 mm x 273 mm)

Tube Reflector System:

- Weight: 60 pounds (27 kg)
- Dimensions: 103.5" L x 16.5" W x 7.5" H (2629 mm x 420 mm x 190 mm)

FIGURE 16 P40-R DIMENSIONS

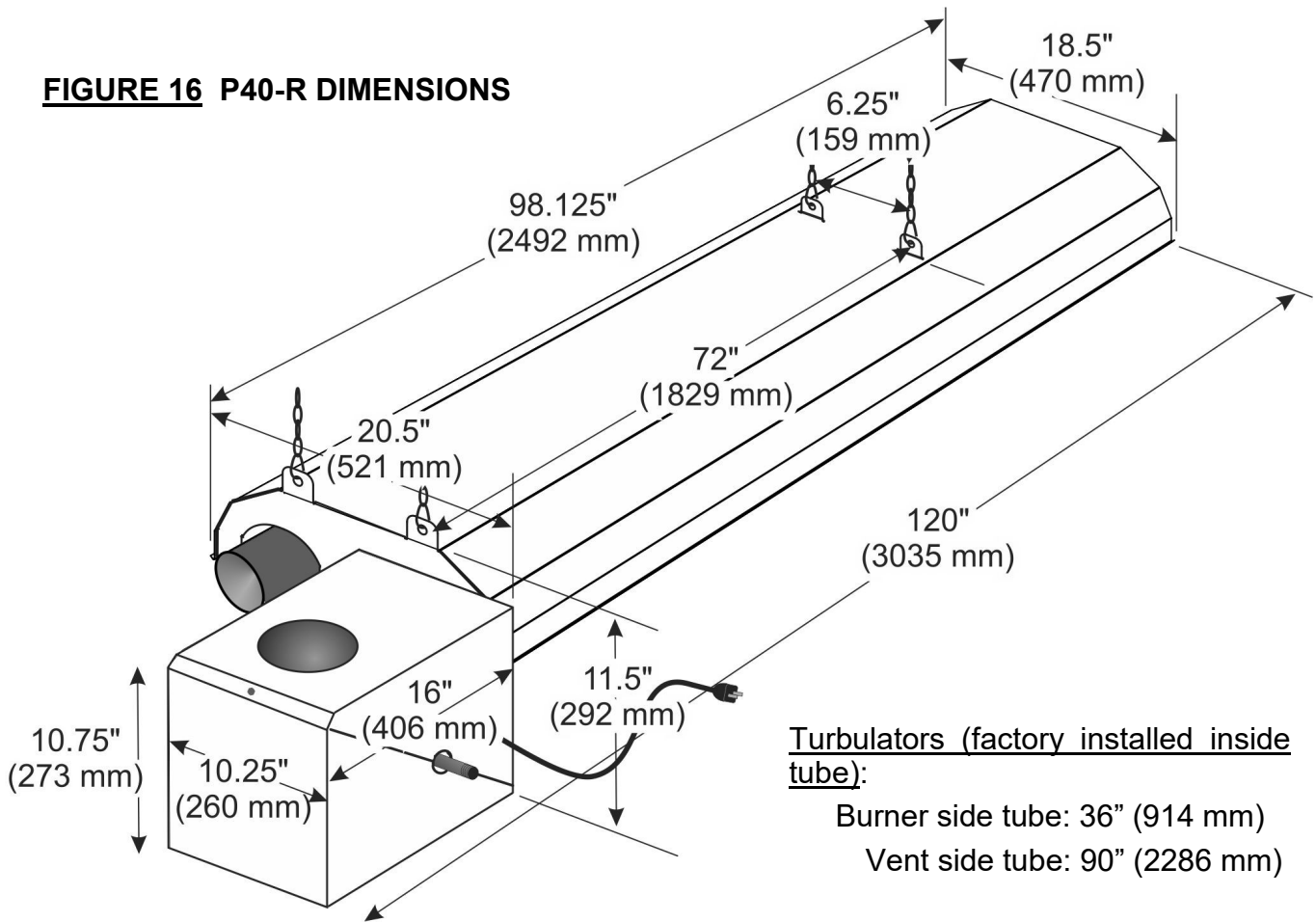

31. HIGH ALTITUDE INSTALLATION

When this appliance is installed above the altitude stipulated below, the input must be de-rated by 4% for each 1000 ft . **If your local utility supplies gas with a de-rated heat content, no orifice change is required in the heater** . Check with your local utility regarding de-rating.

USA: The factory installed orifice for this appliance is approved for altitudes zero to 2000 feet above sea level. Above 2000 feet, refer to table below.

Canada: The factory installed orifice for this appliance is approved for altitudes zero to 4500 feet above sea level. When installed above 4500 feet, refer to the table below

ORIFICE CHART - ALTITUDE CONVERSION

MODEL NO	FOR USE AT ALTITUDES ABOVE (FEET) Gas Orifice Drill Size / Part #							
	Supplied	USA Only			USA & CANADA*			
	0	2000	3000	4000	5000	6000	7000	8000
P40-R / P40-IR NG	31 DMS JS-0731-DM	3 mm JS-0730-MM	32DMS JS-0732-DM	32DMS JS-0732-DM	33DMS JS-0733-DM	34DMS JS-0734-DM	7/64 JS-0731-IN	36DMS JS-0736-DM
P40-R / P40-IR LPG*	49 DMS JS-0749-DM	50 DMS JS-0750-DM	50 DMS JS-0750-DM	50 DMS JS-0750-DM	51 DMS JS-0751-DM	51 DMS JS-0751-DM	51 DMS JS-0751-DM	52 DMS JS-0752-DM

* Field Conversion Kit required to convert between fuel gas types:

- Part number: JS-0555-XA P40U - Natural Gas to Propane Gas Conversion Kit
- Part number: JS-0555-XB P40U - Propane Gas to Natural Gas Conversion Kit

32. OPTIONAL ACCESSORIES

Flue Vent Terminal

4" wall horizontal

6" wall horizontal

JA-0528-XX

JA-0529-XX



Clearance Sign - Metal 18" x 6"

- Required in some jurisdictions:

- Vehicle service garages
- 3/4" high red lettering on white background

JL-0798-CS



#2 Lion Chain (115 lb work load)
- 200 ft roll

JL-0800-XX

Safety Snap Hooks - 2" - pkg of 25
- pkg of 100



JL-0800-SH

JL-0800-SH-B



TruTemp Infrared Setback Thermostat

True comfort control for radiant heating systems - senses and averages ambient and radiant temperatures.

Occupancy sensor with auto set-back of 9°F (5°C).

Do not use in wet or corrosive environments

JM-0150-XX



24 Volt Option: Control Center

Use when Multiple Tube Heaters are controlled by a single 24V Thermostat or TruTemp (for field mounting)

JM-0303 -KT

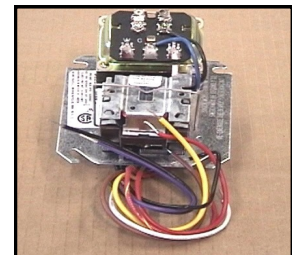

Check local codes for compliance:

Stainless Steel Flexible Gas Connector
1/2" x 24"

JL-0771-XX



JS-0502-UR-GK PROTECTIVE GUARD SCREEN OPTION

– Recommended for heater mounted with less than 8 feet [2.4 m] between floor and bottom of heater



Two sections make up the protective guard assembly that installs on the underside of the P40-R heater. Near the bottom edge at each side of the reflector are two sets of three holes. Each set of holes has one round hole at the center of the reflector, the other two holes are elongated and positioned between the center and the ends of the reflector. The pins that extend from each side of the two guard sections are inserted into these sets of holes.



Fig. 1



Fig. 2

Step 1: On ONE SIDE of the reflector, remove the bottom screws (Qty 3) that fasten the reflector to the end and center hanger brackets, Fig. 1. Retain screws for re-attachment of reflector .

Step 2: On the side of the reflector that remains securely fastened to the hangers, insert a pin located at the end of the Protective Guard into one of the 1/8" round holes located at the center of the reflector, Fig. 2



Fig. 3



Fig. 4

STEP 3: Continue installing pins into the reflector until all three pins on one side of the heater are inserted, Fig 3.

STEP 4: Swing the guard up to the opposite side of the reflector that was loosened from the hangers, Fig.4.



Fig.5



Fig. 6

STEP 4: On the second side of the reflector, first Insert a guard pin into the center hole, Fig 5. Insert remaining guard pins in the reflector holes, Fig 6.

Step 5: Repeat the process with the second guard section.



Fig. 7

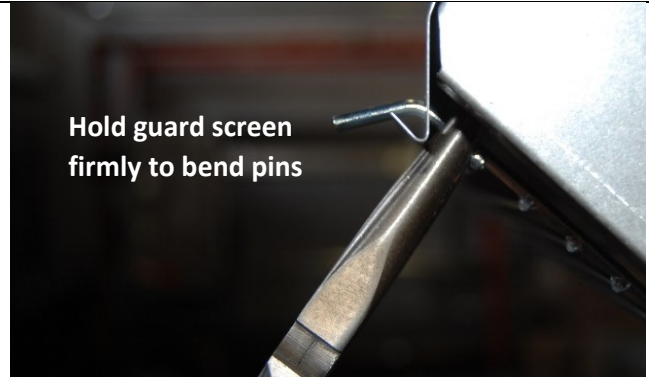

Fig. 8

Step 6: Re-install the screws at the bottom edge of the reflector into the three hangers, Fig. 7.

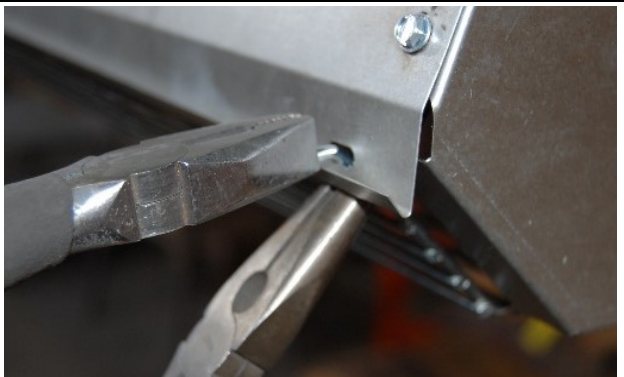

Fig. 9



Fig. 10 (Center)

Fig. 11 (End)

Notes:

- 1) To bend the pins, use needle nose pliers to hold the guard screen securely, Fig.8 and another set of pliers to bend the pin sideways, Fig.9.
- 2) DO NOT bend the pins downwards, it can damage the edge of the reflector.

STEP 7: To secure the guard in place bend the end pins of each guard section sideways and towards each other, Fig. 10 & 11. The center pin does not require bending.

33. REPLACEMENT PARTS LIST

P40-R BURNER

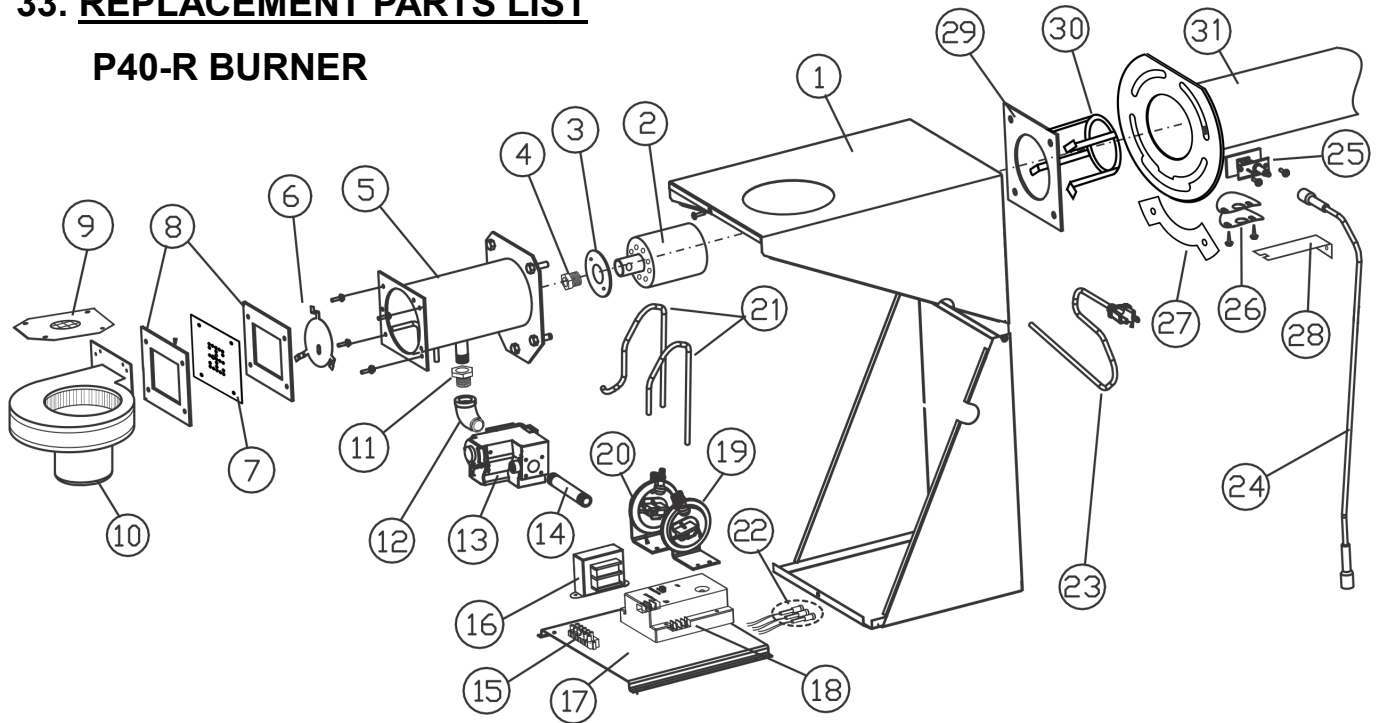

#	PART DESCRIPTION	PART #	PART DESCRIPTION PRIMARY	MODEL
1	BURNER HOUSING:	JS-0582-XX	Burner housing coated gray	P40-R, P40-IR
2	BURNER CUP	JS-0510-LP	Burner Cup 40,000	40 NG & LP
3	AIR RESTRICTOR RING	JS-0596-AA	Burner Cup air restrictor ring - 9/32"	40 NG & LP
4	MAIN BURNER ORIFICE NG	JS-0731-DM	Gas orifice low intensity HR 31 DMS	40,000 NG
	MAIN BURNER ORIFICE LPG	JS-0749-DM	Gas orifice low intensity HR 49 DMS	40,000 LP
5	BURNER CHAMBER	JS-0504-XX	Burner Chamber	All
6	AIR RESTRICTOR	JS-0592-RF	Burner air restrictor P40-R	40 NG & LP
7	EQUALIZER PLATE NG	JS-0593-EP-R	Outlet equalizer plate 40,000 - 13 Holes	40 NG & LP
8	BLOWER GASKET	JS-0578-XX	Blower gasket - Outlet	Each
9	AIR INTAKE SCREENED RESTRICTOR	JS-0595-AC	Air Intake Restrictor - 1.5" Hole	40 NG & LP
10	BLOWER	JS-0579-AA	Blower Assembly Tube Burner	
11	MANIFOLD BUSHING	JM-0589-XX	Manifold bushing	
12	90 DEGREE ELBOW FITTING 1/2"	JS-0588-XX	Street elbow fitting 90 deg	
13	GAS VALVE - NG	JL-0701-AA	Gas Valve comb 3.5" WC 24VAC VR8 NG	40,000 NG
	GAS VALVE - LPG	JL-0703-AA	Gas Valve comb 10" WC 24VAC VR8 LP	40,000 LPG
14	4" NIPPLE	JS-0590-XX	Nipple 4"	
15	TERMINAL BLOCK	JM-0455-DD	Terminal block - Electrical Connections	
16	STEP DOWN TRANSFORMER	JA-0775-XX	Transformer 120/24V, 20VA	
17	COMPONENT PLATE	JS-0581-SE	Component mounting plate SE	
18	IGNITION CONTROL	JA-0567-XX	Fenwal 3-Trial 24Vac with blower relay	<i>Also see kit</i>
19	COMBUSTION AIR PROVING SWITCH	JS-0576-UG	Air Proving Switch 1.00" WC	
20	BLOCKED FLUE PROVING SWITCH	JS-0577-RR	Blocked Flue Switch 0.46" WC	
21	PRESSURE SWITCH TUBING	JS-0572-SE	Tubing set 2 x 20" PVC SE	
22	INDICATOR LAMPS	See Next Page		

Burners with FENWAL IGNITION CONTROL - Models: P40U-F; P40U-I-F

18	FENWAL DSI CONTROL	JA-0567-XX	Fenwal 3-Trial 24Vac with blower relay	"-F" Models
	REPLACEMENT KIT: FENWAL & S87J	JA-0568-KT	Fenwal Control + Wire Harness + Cable + Igniter: Replaces S87J	
24	IGNITION CABLE	JS-0518-SA	Hi voltage wire (24") STW - 2 x 1/4" Spades	

Burners with HONEYWELL S87-J IGNITION CONTROL - Models: P40U; P40U-I

18	HONEYWELL IGNITION CONTROL	JA-0568-XX	DISCONTINUED - NO LONGER AVAILABLE	
	REPLACEMENT KIT: FENWAL CONTROL	JA-0568-KT	Fenwal Control + Wire Harness + Cable + Igniter	
24	IGNITION CABLE HONEYWELL S87J	JS-0518-XX	Wire hi voltage (24") S87J Bullet Connection	

Burners with CHANNEL GASLITER MICRO 50N IGNITION CONTROL

18	IGNITION CONTROL	JB-0568-AA	Control - DSI 3 Try potted Gasliter MICRO 50N	
24	IGNITION CABLE	JS-0518-SA	Hi voltage wire (24") STW - 2 x 1/4" Spades	
	MICRO 50N WIRING HARNESS	JB-0568-WH	3 Try potted spark DSI control wiring harness	Not Shown
	WIRING KIT (not shown)	JW-WXXX-HX	Wiring kit w/ Harness - Micro 50N	Not Shown

#	PART DESCRIPTION	PART #	PART DESCRIPTION PRIMARY	
	WIRING KIT (not shown)	JW-SUXX-HX	Low Voltage Wiring Kit w/ Harness	
22	INDICATOR LAMPS	JW-0519-AM	Indicator light amber	
		JW-0519-GR	Indicator light green	
		JW-0519-RE	Indicator light red	
23	ELECTRICAL CORD	JB-0567-XX	Cord - electrical 6'	
24	IGNITION SPARK CABLE	See Above		
25	IGNITER KIT	JA-0571-KT	Spark Igniter & Gasket Kit	
26	SIGHT GLASS ASSEMBLY	JS-0536-XX	Sight glass assembly - tube heater	
27	FLANGE WASHER PLATE	JS-0501-UW	Washer plate - Bottom 2 Burner studs	
28	TUBE FASTENING BRACKET	JS-0502-UV	Positions tube in hanger / reflector assembly	
29	FLANGE GASKET	JS-0591-XX	Flange Adapter Gasket	
30	FLAME RECTIFIER	JS-0592-RR	Flame Rectifier	

Contact your local Schwank or InfraSave distributor for replacement parts.

P40-R TUBE / REFLECTOR SYSTEM

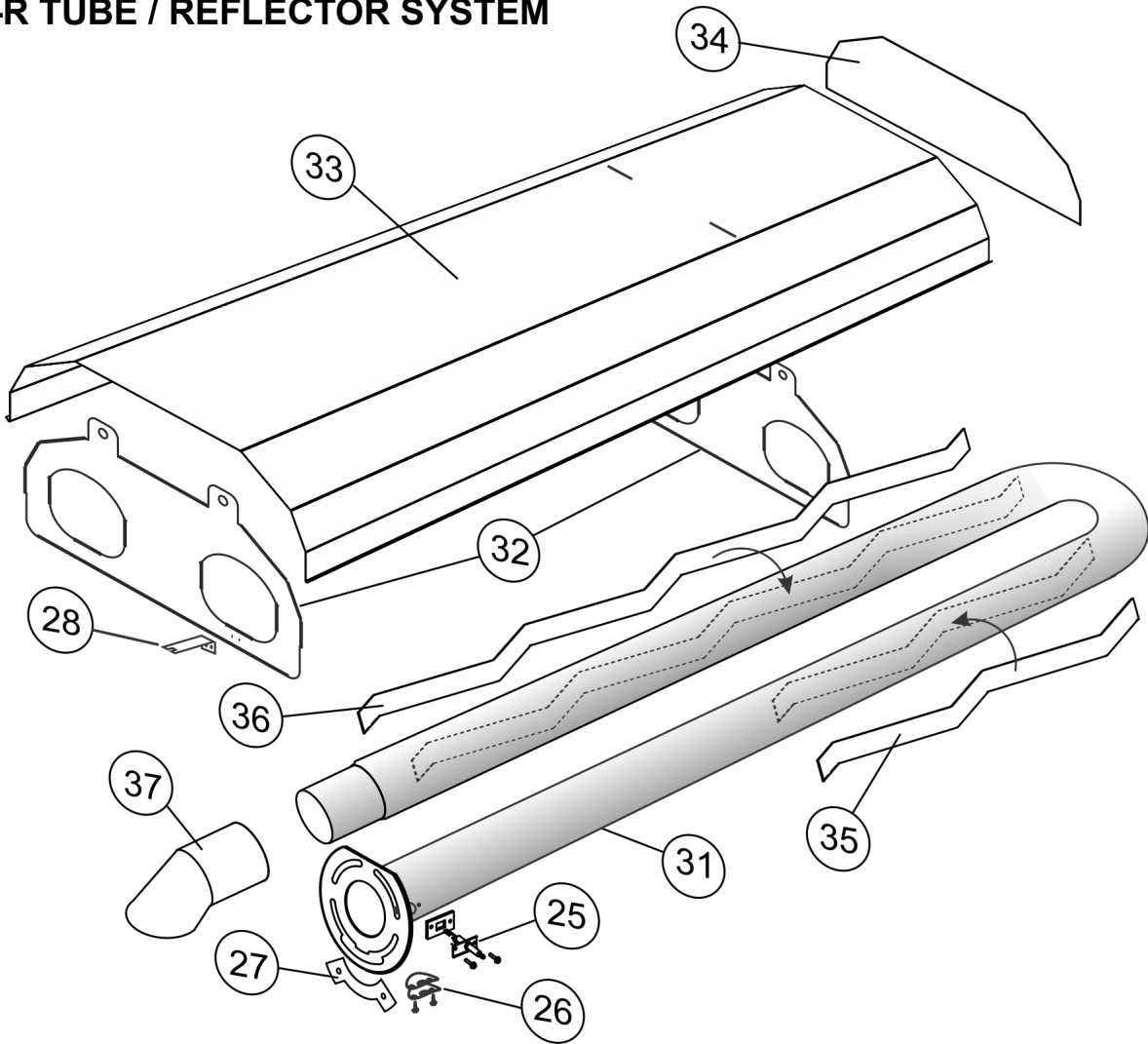

25	IGNITER KIT	JA-0571-KT	Spark Igniter & Gasket Kit	
26	SIGHT GLASS ASSEMBLY	JS-0536-XX	Sight glass assembly - tube heater	
27	FLANGE WASHER PLATE	JS-0501-UW	Washer plate - Bottom 2 Burner studs	
28	TUBE FASTENING BRACKET	JS-0502-UV	Positions tube in hanger / reflector system	
31	PREFORMED U-TUBE	JS-0501-UT-R	Preformed U-Tube: 17 ft tube length	
32	P40-R HANGER	JS-0506-UH-R	P40-R System Hanger	
33	P40-R REFLECTOR	JS-0502-UR-R	Reflector for P40-R	
34	REFLECTOR END PLATE	JS-0502-UT-R	Reflector End Plate	
35	P40-R TURBULATOR 39"	JS-0533-SK	39" S/S Turbulator In Burner Side Tube	
36	P40-R TURBULATOR 90"	JS-0533-UT	90" Turbulator In Vent Side Tube	
37	OPTIONAL VENT CAP	JA-0528-XX	Horizontal side wall 4" vent terminal	Optional Item
	OPTIONAL GUARD SCREEN	JS-0502-UR-GK	2 Section Guard Screen fits below tube	Not Shown

Contact your local Schwank or InfraSave distributor for replacement parts.

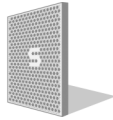

FOR GAS-FIRED OVERHEAD VENTED ROOM HEATER : P40-R & P40R-I SERIES

The Manufacturer warrants that this product is free from defects in material or workmanship under normal use and service subject to the terms of this document.

THREE YEAR WARRANTY

Subject to the conditions and limitations stated herein, during the term of this limited warranty, the manufacturer will supply any component part (at their option a new or repaired component part) of the heater as defined below, excluding any labor, which the Manufacturer's examination determines to be defective in workmanship or material for a period of three years (3 years) from the date of installation, unless otherwise specified below. This warranty applies to the heater's original owner, and subsequent transferees and only if the unit is installed and operated in accordance with the printed instructions accompanying the unit and in compliance with all applicable installation codes and good trade practices. Warranty of replacement parts is limited to a period of one year (1 year).

WHAT IS NOT COVERED

The Manufacturer shall not be responsible for any expenses, including service, labor, diagnosis, analysis, material or transportation charges incurred during removal or reinstallation of this product, or any of its components or parts. All labor or service charges shall be paid by the owner. This warranty does not cover heating products improperly installed, misused, exposed to or damaged by negligence, accident, corrosive or contaminating atmosphere, water, excessive thermal shock, impact, abrasion, normal wear due to use, alteration or operation contrary to the owner's manual or if the serial number has been altered, defaced or removed. This warranty shall not apply if the input to the heating product exceeds by more than 2% of the rated input on the rating plate. The Manufacturer shall not be liable for any default or delay in performance by its warranty caused by any contingency beyond its control, including war, government restrictions, or restraints, strikes, fire, flood, acts of God, or short or reduced supply of raw materials or products.

WARRANTY PROCEDURE

To establish the installation date for any purpose under this Limited Warranty, you must retain the original records that can establish the installation date of your unit. If you do not provide such documents, the start date of the term of this Limited Warranty will be based upon the date of unit manufacture, plus thirty (30) days. Failure to maintain the equipment through regular annual service maintenance by a qualified service technician shall void the warranty.

LIMITATIONS AND EXCLUSIONS

This document contains all warranties made by the Manufacturer and may not be varied, altered or extended by any person. There are no promises, or agreements extending from the Manufacture other than the statements contained herein. THIS WARRANTY IS IN LIEU OF ALL WARRANTIES EXPRESSED OR IMPLIED, TO THE EXTENT AUTHORIZED BY THE LAWS OF THE JURISDICTION, INCLUDING SPECIFICALLY THE WARRANTIES OR MERCHANTABILITY OF FITNESS FOR A PARTICULAR PURPOSE.

It is understood and agreed that the Manufacturer's obligation hereunder is limited to repairing or replacing parts determined to be defective as stated above. In no event shall the Manufacturer be responsible for any alleged personal injuries or other special, incidental or consequential damages. As to property damages, contract, tort or other claim the Manufacturer's responsibility shall not exceed the purchase priced paid for the product.

All replacement parts will be warranted for the unused portion of the warranty coverage period remaining on the applicable unit.

Some Authorities do not allow certain warranty exclusions or limitations on duration of warranty or the exclusions or limitations of incidental or consequential damages. In such cases, the above limitations or exclusions may not apply to you and are not intended to do so where prohibited by law. This warranty gives you specific legal rights. You may also have other rights which vary by jurisdiction.

SCHWANK GROUP
2 SCHWANK WAY, WAYNESBORO, GEORGIA. 30830
5285 BRADCO BLVD. MISSISSAUGA, ON, L4W 2A6

Ph: 1-877-446-3727 Fax: 1-866-361-0523
www.SchwankGroup.com www.InfraSave.com