



INSTALLATION, OPERATION, AND SERVICE MANUAL

**NOBLE CG-115
NOBLE CG-1200**



REVISION HISTORY

Revision	Date	Made by	Process	Details
A	7-23-15	KAP	QOF-386	Initial release of manual.
B	1-19-16	JH	QOF-386	Added CG-115 and associated views, parts lists, and schematics to the manual.
C	4-26-16	JH	8379	Updated schematic on pg. 48.
D	9-21-16	JH	N/A	Updated manual to new format. Removed "iodine" and "type of sanitizer used" from pg. 8. Replaced exploded views throughout with more legible views. Updated P/N of Power Disconnect Decal on pgs. 35 and 36. Updated P/N of item #8 on pg. 37. Updated P/N of item #1 on pg. 40. Updated P/N and description of item #13 on pg. 43. Updated P/N and description of item #15 on pg. 43.
E	7-12-17	JH	8453	Corrected pg. 2, switched "Hot" and "Cold." Corrected flow pressure on pg. 3. Added Iodiphor as a sanitizer on pg. 3 and updated the reference to sanitizers on pg. 8. Corrected P/N of item #4 on pg. 35 and item #6 on pg. 36. Changed P/N of item #7 and added P/N for entire bottom inlet manifold assembly on pg. 39. Added view and image of drain o-ring installation to pg. 41. Added rinse strainer, wash tank, and o-ring to pgs. 41 and 42. Changed P/N of item #10b on pg. 42.
F	6-18-18	JH	8593 8633	Updated instructions on pgs. 11-14 to show stop caps. Added delimiting instructions to pg. 15. Added bottom stop cap and top stop cap with hardware to pgs. 39-40. Changed P/N of item #7 on pg. 40. Added optional accumulator tray kit to pg. 42. Added deflector strainer to pgs. 43-44.
G	11-9-18	JH	8644 8645 8666	Updated drawing on pg. 2. Added minimum inlet water temperature on pg. 3. Updated plumbing assemblies on pgs. 39-40. Updated manifold injection assembly on pgs. 39-40. Added link to accumulator tray install instructions on pg. 42.
H	2-26-21	JH	8709 8788 8799	Updated dimensional drawing. Revised peri-pumps assemblies. Updated schematics.
J	10-4-21	JH	N/A	Updated electrical requirements.
K	2-25-22	JH	22-10872	Consolidated two schematics into one.
L	5-18-22	JH	22-1202	Updated Chemical Feeder Pump Assembly section with black dot roller.
M	12-12-22	JH	8901 22-1424	Corrected data plate location on pg. 7. Changed P/N of relay on pg. 36. Updated peri-pumps to black components. Added P/Ns for elbow and fitting to Wash System section.
N	1-29-24	JH	23-2021	Updated drain line size. Corrected footnote on Item #18 in Wash System section. Corrected Item #7 in Chemical Feeder Pump Assembly section. Added foam gasket to tub. Updated manifold assembly. Changed hinge on gear box to tilt hinge and updated spring P/N. Added conveyor guards. Updated schematic.



CG-115

115 V glasswasher dishmachine; chemical-sanitizing, carousel-type, electric tank heat, with detergent, rinse-aid, and sanitizer chemical feeder pumps.

CG-1200

208 V glasswasher dishmachine; chemical-sanitizing, carousel-type, electric tank heat, with detergent, rinse-aid, and sanitizer chemical feeder pumps.

The manufacturer provides technical support for all of the dishmachines detailed in this manual. We strongly recommend that you refer to this manual before making a call to our technical support staff. Please have this manual open when you call so that our staff can refer you, if necessary, to the proper page. Technical support is not available on holidays. Contact technical support toll free at 1-888-800-5672.

Technical support is available for service personnel only.

TABLE OF CONTENTS

GUIDES

Symbols.....	1
Abbreviations & Acronyms	1

SPECIFICATIONS

Machine Dimensions	2
Operating Parameters	3
Electrical Requirements	4

INSTALLATION

Installation Instructions.....	5
<i>Inspection</i>	5
<i>Unpacking</i>	5
<i>Leveling</i>	5
<i>Plumbing</i>	5
<i>Water Supply Connection</i>	6
<i>Pressure Regulator</i>	6
<i>Shock Absorber</i>	6
<i>Connecting the Drain Line</i>	6
<i>Plumbing Check</i>	6
<i>Electrical Power Connections</i>	7
<i>Voltage Check</i>	7
<i>Surrounding Area</i>	7
<i>Thermostats</i>	8
<i>Chemical Feeder Equipment</i>	8
<i>Preparing Chemical Feeder Pumps</i>	8
<i>Priming Chemical Feeder Pumps</i>	8

OPERATION

Operating Instructions	9
<i>Preparation</i>	9
<i>Filling the Wash Tub</i>	9
<i>Ware Preparation</i>	10
<i>Washing a Rack of Ware</i>	10
<i>Operational Inspection</i>	10
<i>Shutdown & Cleaning</i>	11
<i>After Cleaning</i>	13
<i>Detergent Control</i>	15
<i>Deliming</i>	15

TABLE OF CONTENTS

MAINTENANCE

Preventative Maintenance.....	16
-------------------------------	----

TROUBLESHOOTING

Common Problems.....	17
----------------------	----

SERVICE PROCEDURES

Chemical Feeder Pump Motor Replacement	21
Wash Tank Heater Replacement.....	24
Thermostat Replacement.....	29
Wash Motor Replacement.....	32

PARTS

Control Box Assembly - CG-115.....	35
Control Box Assembly - CG-1200	36
Chemical Feeder Pump Assembly	37
Rinse Assembly.....	39
Wash System	41
Conveyor & Drive System	43
Door Assembly	45
Outer Shell Assembly	46
Plumbing Options	47

SCHEMATICS

Glasswasher Schematic.....	48
----------------------------	----

SYMBOLS



- Risk of Injury to Personnel



- Risk of Damage to Equipment



- Risk of Electrical Shock



- Caustic Chemicals



- Reference Data Plate



- Lockout Electrical Power

NOTICE

- Important Note



- Instructions Hyperlink

ABBREVIATIONS & ACRONYMS

ANSI - American National Standards Institute

GHT - Garden Hose Thread

GPH - Gallons per Hour

GPM - Gallons per Minute

GPG - Grains per Gallon

HP - Horse Power

Hz - Hertz

ID - Inside Diameter

kW - Kilowatts

NFPA - National Fire Protection Association

NPT - National Pipe Thread

PPM - Parts per Million

PSI - Pounds per Square Inch

V - Volts

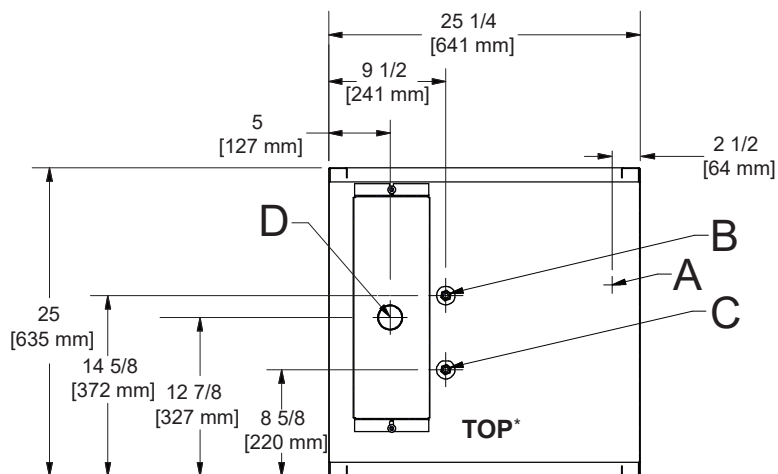

LEGEND

- A - Electrical Connection
- B - Water Inlet, Hot, 1/2"
- C - Water Inlet, Cold, 1/2"
- D - Drain Connection, 2"

All dimensions from the floor can be increased $1 \frac{1}{4}$ " using the machine's adjustable feet.

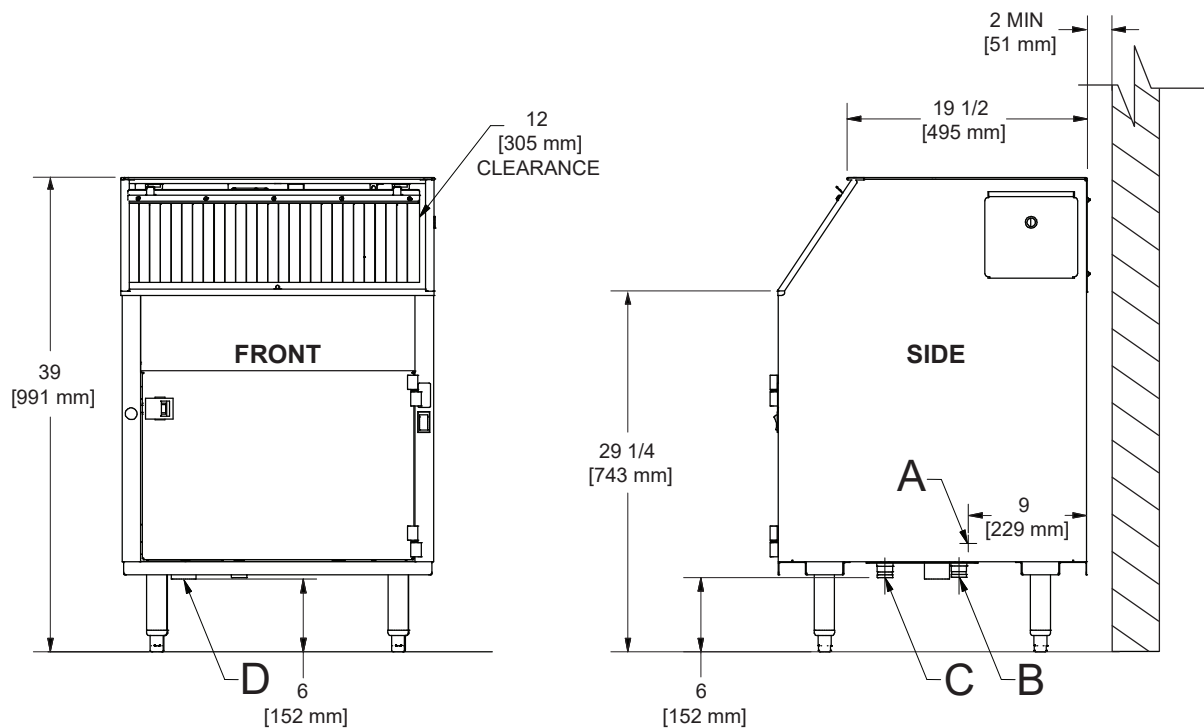

NOTICE All dimensions are for reference only and are subject to change without notice.

*Cut view showing machine base from top.

	CG-115	CG-1200
Operating Capacity:		
Glasses per Hour	1200	1200
Operating Cycle (Seconds):		
Total Cycle Time	120	120
Tank Capacity (Gallons):		
	3.0	3.0
Wash Pump Capacity (GPM):		
	55	55
Water Temperatures (°F):		
Minimum Inlet Temperature	120	130
Minimum Wash Temperature	120	130
Minimum Rinse Temperature	75	75
Other Water Requirements:		
Cold Water Flow Pressure (PSI)	20 ± 5	20 ± 5
Hot Water Flow Pressure (PSI)	20 ± 5	20 ± 5
Gallons per Hour	10.0	10.0
Water Line Size (NPT)	1/2"	1/2"
Drain Line Size (NPT)	2"	2"
Minimum Chlorine Required (PPM)	50	50
Minimum Iodiphor Required (PPM)	12.5	12.5
Electrical Loads (as applicable):		
Wash Motor (HP)	0.1	0.1
Wash Heater (kW)	1.3	2.7 (208 V)/3.3 (230 V)



NOTICE *Always refer to the machine data plate for specific electrical and water requirements. The material provided on this page is for reference only and is subject to change without notice.*

NOTICE



All electrical ratings provided in this manual are for reference only. Always refer to the machine data plate to get exact electrical information for this machine. All electrical work performed on machines should be done in accordance with applicable local, state, territorial, and national codes. Work should only be performed by qualified electricians and authorized service agents.

Amperage loads for motors and heaters are indicated on the machine data plate.

The electrical configurations are as follows:

Available Electrical Characteristics:

CG-115

- 115 V, 60 Hz, Single-phase

CG-1200

- 208 V, 60 Hz, Single-phase
- 230 V, 60 Hz, Single-phase

CG-115
Electrical Characteristics

VOLTS	115
PHASE	1
FREQ	60
WASH MOTOR AMPS	2.5 A
WASH HEATER AMPS	10.4 A
TOTAL LOAD	12.9 A
MCA	13.5 A
MOP	15 A

CG-1200
Electrical Characteristics

VOLTS	208	230
PHASE	1	1
FREQ	60	60
WASH MOTOR AMPS	0.5 A	0.4 A
WASH HEATER AMPS	12.9 A	14.3 A
TOTAL LOAD	13.4 A	14.7 A
MCA	13.5 A	14.8
MOP	15 A	15 A

INSPECTION

Do not throw away container if damage is evident!

Before installing the machine, check packaging and machine for damage. Damaged packaging might be an indication of damage to the machine. If there is any type of damage to both packaging and machine, do not throw away the packaging. The machine has been inspected at the factory before shipping and is expected to arrive in new, undamaged condition. However, rough handling by carriers or others might result in damage to the machine while in transit. If this occurs, do not return the machine to the manufacturer. Instead, contact the carrier and ask them to send a representative to the site to inspect the damage and request that an inspection report be completed.

Contact the carrier within 48 hours of receiving the machine as well as the dealer that sold you the machine.

UNPACKING

The machine should be unpacked and removed from the pallet before installing. Remove all of the materials from inside. Once unpacked, verify there are no missing parts. If a part is missing, contact the manufacturer immediately.

LEVELING

The machine is designed to operate while level. This is important to prevent any damage to the machine during operation and to ensure the best possible results. The machine comes equipped with adjustable bullet feet which can be turned using a pair of pliers. Verify the machine is level from front-to-back and side-to-side before making any electrical or plumbing connections.

PLUMBING

The plumber must flush the incoming water line!

All plumbing connections must be made to adhere to local, state, territorial, and national codes. The installing plumber is responsible for ensuring the incoming water lines are flushed of debris before connecting to the machine. Note that chips and materials from cutting processes can become lodged in the solenoid valves and prevent them from opening or closing. Any valves that are found to be fouled or defective because of foreign matter left in the water line, and any subsequent damage, are not the responsibility of the manufacturer.

Cold water supply must be a minimum of 75 °F with a capacity of 180 GPH at 8-12 PSI. Hot water supply must be a minimum of 120 °F (CG-1200)/130 °F (CG-115) with a capacity of 10 GPH at 20 ± 5 PSI. Incoming hot and cold water service connections (supplied by customer) must be a 1/2" NPT pipe size minimum. Install the water supply line to the machine using copper pipe. A water shut-off valve should be installed in the water line between the main supply and the machine to allow access for service.

A water hardness test must be performed. If water hardness is higher than 3 GPG, install a water softener or install the optional Scale Prevention System (SPS). See the next section and the Plumbing Options page for more information on the SPS.

A water hardness test must be performed.

**WATER SUPPLY CONNECTION:
WATER HARDNESS HIGHER THAN 3 GPG**

If water hardness is higher than 3 GPG and a water softener is not being used, install the SPS into the water line between the facility water line and the machine water line. Observe proper inlet/outlet water directions (flow directions are molded into the top of the head). A water shut-off valve should be installed before installing the SPS to allow access for service.

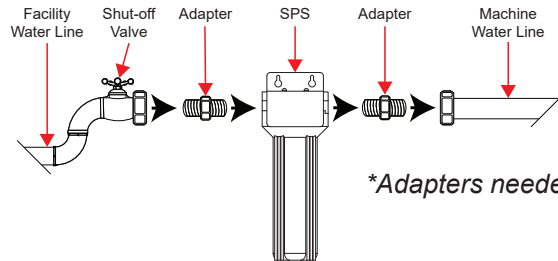

**WATER SUPPLY CONNECTION:
WATER HARDNESS LOWER THAN 3 GPG**

If water hardness tests at 3 GPG or lower, connect the machine water line to the facility water line. A water shut-off valve should be installed in the water line between the facility supply and the machine to allow access for service.

PRESSURE REGULATOR

The manufacturer has an optional water pressure regulator (see Plumbing Options page) to accommodate areas where water pressure fluctuates or is higher than the recommended pressure. Take care not to confuse static pressure with flow pressure: static pressure is line pressure in a “no flow” condition (all valves and services are closed); flow pressure is the pressure in the fill line when the valve is opened during the cycle.

Take care not to confuse static pressure with flow pressure!

SHOCK ABSORBER

An optional shock absorber (see the Plumbing Options page) should be installed on the incoming water line. This prevents water hammer (hydraulic shock)—induced by the solenoid valve as it operates—from causing damage to the equipment.

CONNECTING THE DRAIN LINE

The CG glasswashers have a gravity drain (2” NPT connection). All piping from the machine to the drain must be a minimum 2” NPT and must not be reduced. There must also be an air-gap between the machine drain line and the floor sink or drain. If a grease trap is required by code, it should have a flow capacity of 5 GPM.

PLUMBING CHECK

After installing the incoming fill line and the drain line, slowly turn on the water supply to the machine. Check for any leaks and repair as required. All leaks must be repaired before operating the machine.

ELECTRICAL POWER CONNECTIONS



Disconnect electrical power at the breaker or disconnect switch and tag-out in accordance with procedures and codes.

Electrical and grounding conductors must comply with the applicable portions of the National Electric Code ANSI/NFPA 70 (latest edition) and/or other electrical codes.

The data plate is behind the door. Refer to the data plate for machine operating requirements, machine voltage, total amperage, and serial number.

Remove the electrical box cover. This will require removing the screws at the bottom with a phillips screwdriver and lifting it up and off. Install 3/4" conduit from the underside of the machine to the hole in the rear of the electrical box. Route power wires and connect to power block and grounding lug. Install the service wires (L1 and L2) to the appropriate terminals as they are marked on the terminal block. Install the grounding wire into the lug provided. It is recommended that "DE-OX" or another similar anti-oxidation agent be used on all power connections.

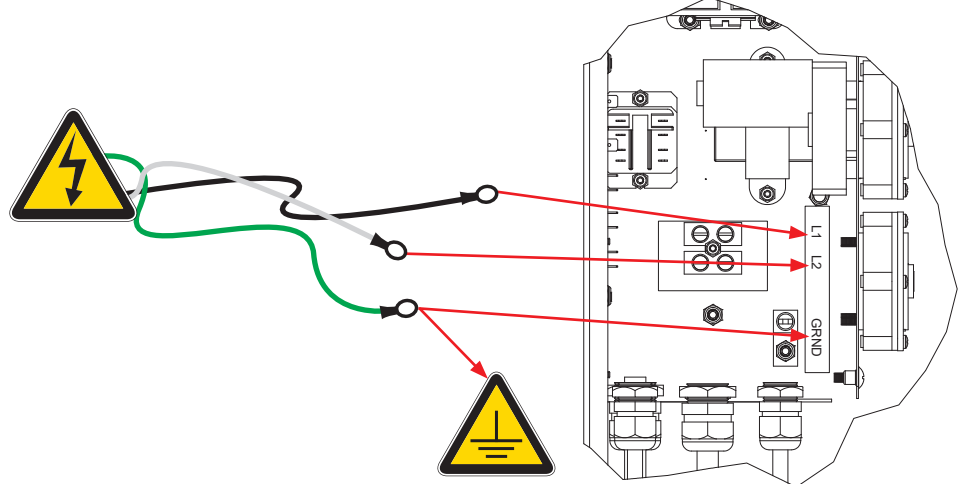

VOLTAGE CHECK



Ensure that the "Power" switch is in the "OFF" position and apply power to machine. Check the incoming power at the terminal block and ensure it corresponds with the voltage listed on the data plate. If not, contact a qualified service agency to examine the problem. Do not run machine if voltage is too high or too low. Shut-off the service breaker and advise all proper personnel of the location of the breaker and any problems. Replace the electrical box cover and tighten-down the screws.

SURROUNDING AREA

This is a commercial machine and reaches temperatures that can exceed those generated by a residential machine. Surrounding countertops, cabinets, flooring material, and subflooring material must be designed and/or selected with these higher temperatures in mind.



CAUTION! Any damage to surrounding area that is caused by heat and/or moisture to materials that are not recommended for higher temperatures will not be covered under warranty or by the manufacturer.

THERMOSTATS The thermostats on this machine have been set at the factory. They should only be adjusted by an authorized service agent.

CHEMICAL FEEDER EQUIPMENT



CAUTION! Chlorine-based sanitizers can be detrimental to this machine if the chemical solution is too strong. See a chemical professional to ensure the dispenser is set-up correctly.

It is important to remember that if you decide to operate the machine in chemical-sanitizing mode, you must ensure an appropriate sanitizer (chlorine or iodophor, see Operating Parameters page for concentrations) is used in the final rinse line.

PREPARING CHEMICAL FEEDER PUMPS

The CG glasswashers are supplied with detergent, rinse-aid, and sanitizer chemical feeder pumps.

Locate the open ends of the chemical tubes with the tube stiffeners and place each one in the appropriate container.

- A. Red Tubing = Detergent
- B. Blue Tubing = Rinse-aid
- C. White Tubing = Sanitizer

PRIMING CHEMICAL FEEDER PUMPS

Chemical feeder pumps need priming when the machine is first installed or if the chemical lines have been removed and air is allowed to enter.



CAUTION! Water must be in the sump and wash tank before chemicals are dispensed. This equipment is not recommended for use with deionized water or other aggressive fluids.

WARNING! Some of the chemicals used in dishwashing might cause chemical burns if they come in contact with skin. Wear protective gear when handling these chemicals. If any contact with skin occurs, immediately follow the treatment instructions provided with the chemicals.

1. Verify the proper chemical tube stiffener inlet is in the proper container.
2. Use the push buttons on the right side of control box to prime each pump.
3. To prime the pumps, hold down each prime switch until the chemical can be seen flowing through the chemical tubes.
4. Detergent is dispensed as required during the wash tank fill. The amount of detergent might need to be increased or decreased depending on water quality and type of detergent. It is adjusted by turning the potentiometer on the speed control board clockwise to increase, counter-clockwise to decrease.
5. Rinse-aid is dispensed proportionally into the final rinse water line. The amount of rinse-aid might need to be adjusted depending on water quality and results. It is adjusted by turning the potentiometer on the speed control board clockwise to increase, counter-clockwise to decrease.
6. Sanitizer is dispensed proportionally into the final rinse water line. The amount of sanitizer might need to be adjusted depending on concentration. It is adjusted by turning the potentiometer on the speed control board clockwise to increase, counter-clockwise to decrease.

PREPARATION Before operating the machine, verify the following:

1. Wash strainer is clean and in place.

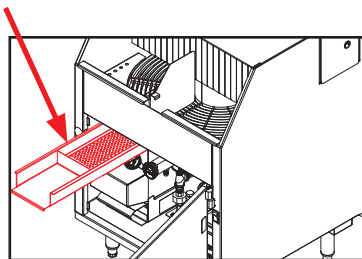

2. Rinse strainer is clean and in place.

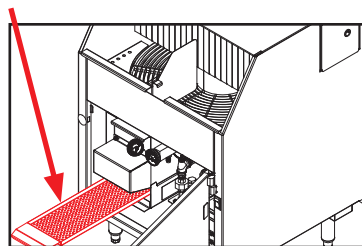

3. The drain stopper is installed.

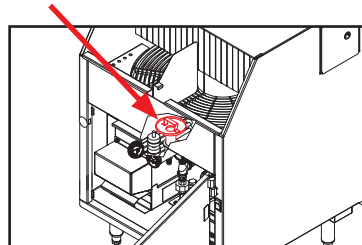

4. Chemical levels in chemical containers are correct.

FILLING THE WASH TUB

1. Place the power switch in the "FILL" position.

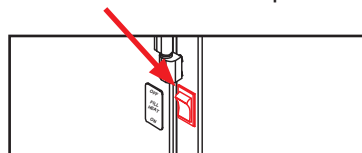

2. The machine will automatically begin to fill.
3. Verify temperatures before operating the machine.

WARE PREPARATION

Proper preparation of ware will help ensure good results and fewer re-washes. If not done properly, ware might not come out clean and the efficiency of the machine will be reduced. Scraps should always be removed from ware before being loaded onto the carousel. Pre-rinsing and pre-soaking are good ideas.

Place cups and glasses upside-down on the carousel so they don't hold water during the cycle. The machine sanitizes as well as cleans. To do this, ware must be properly prepared before being placed in the machine.

WASHING A RACK OF WARE

1. Turn the power switch to the "ON" position; the carousel will begin to rotate.

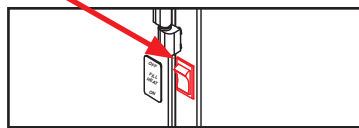

2. Place glasses upside-down on the carousel.

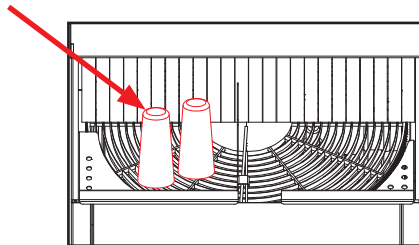

3. When the glasses have completed the cycle, the paddle switch will activate, turning off the water and carousel.
4. Remove clean glasses which are against the paddle switch.

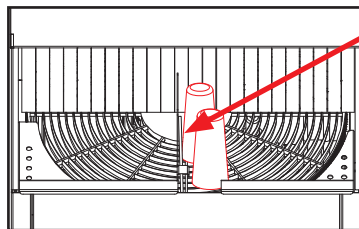

5. The carousel will begin to rotate again.

OPERATIONAL INSPECTION

Strainers can become clogged with soil and debris as the workday progresses. Operators should regularly inspect strainers to ensure they have not become clogged. Clogged strainers reduce the washing capability of the machine and should be cleaned at regular intervals or as required by workload. See the next section.

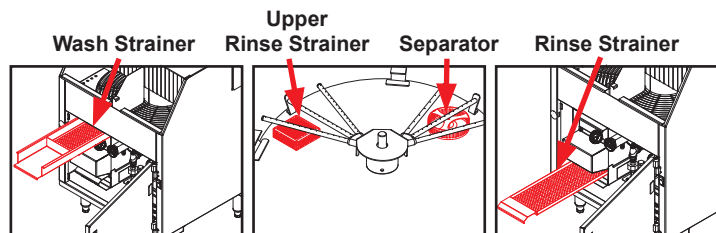

SHUTDOWN & CLEANING



Disconnect electrical power at the breaker or disconnect switch and tag-out in accordance with procedures and codes.



CAUTION!
Do NOT beat strainers to remove debris!

1. Turn power switch to the "OFF" position.

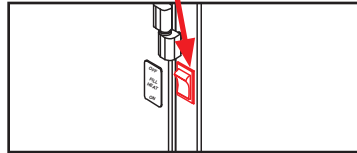

2. Ensure glasses are removed from carousel.

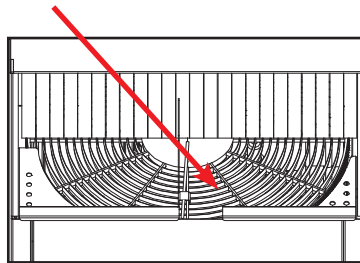

3. Remove and clean wash strainer.

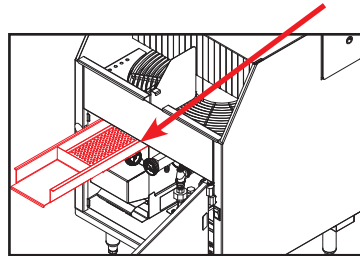

4. Remove and clean drain stopper.

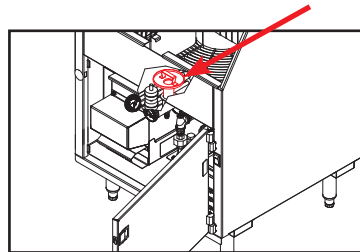

5. Remove curtain, clean with a mild soap, and rinse.

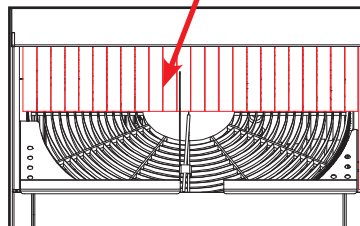

6. Remove and clean drain boards.

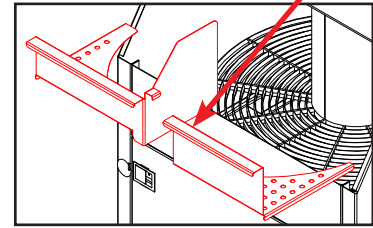

7. Remove and clean rack cylinder.

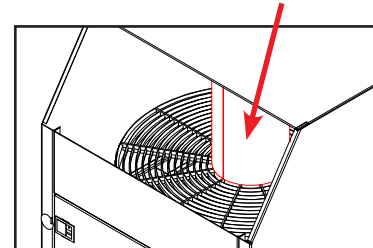

8. Hold paddle switch against wall of machine with one hand.

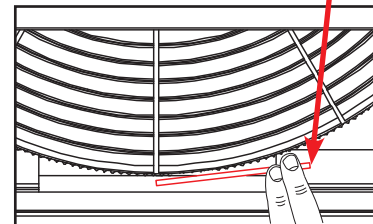

9. Remove carousel with other hand

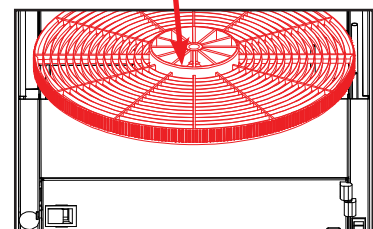

and clean.

10. Rotate top stop cap counter-

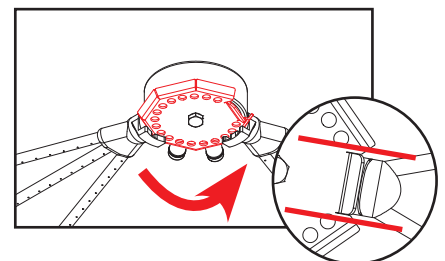

SHUTDOWN & CLEANING

clockwise until opening aligns with top rinse arm.

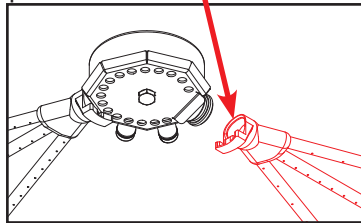

- 11. Remove top rinse arm.
- 12. Rotate top stop cap counter-clockwise until opening aligns with

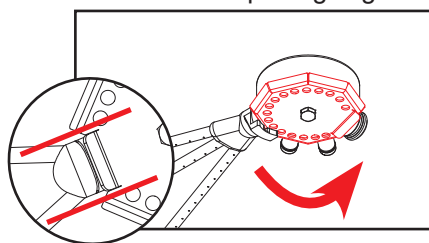

top wash arm.

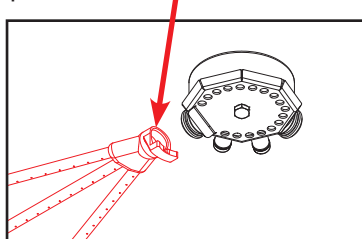

- 13. Remove top wash arm.

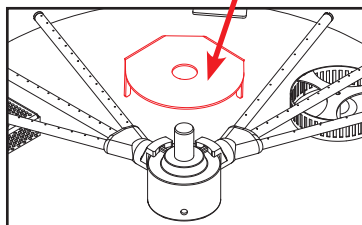

- 14. Remove bottom stop cap.

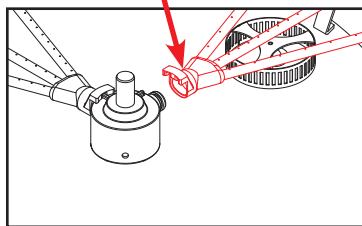

- 15. Remove bottom rinse arm.

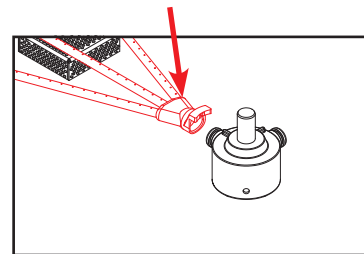

- 16. Remove bottom wash arm.
- 17. On all arms: remove end-caps, clean with a brush, and flush with fresh water.

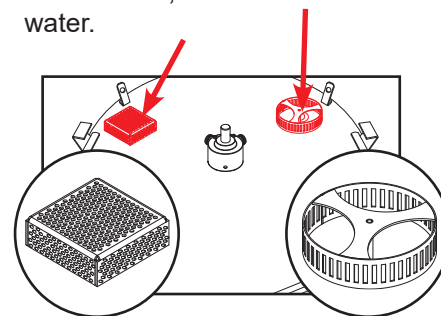

- 18. Remove and clean separator and

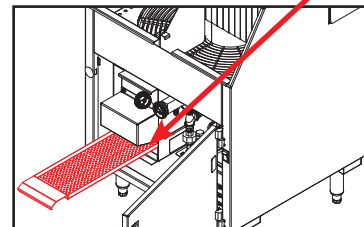

upper rinse strainer.

- 19. Remove and clean rinse strainer.



CAUTION!
Do NOT beat strainers to remove debris!

Bottom stop cap simply lifts off the manifold.

AFTER CLEANING



CAUTION!
Ensure all components are clean before replacing them in the machine!

1. Spray or wipe out interior of machine.
2. Replace rinse strainer.
3. Replace separator and upper rinse strainer.
4. Insert middle of bottom wash arm into support bracket.
5. Push bottom wash arm onto manifold.
6. Insert middle of bottom rinse arm into support bracket.
7. Push bottom rinse arm onto manifold.
8. Replace bottom stop cap.
9. Insert middle of top wash arm into support bracket.
10. Push top wash arm onto manifold.

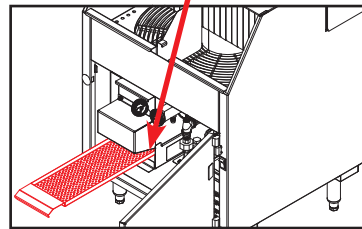
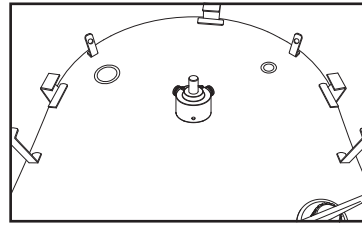

3. Replace separator and upper rinse strainer.

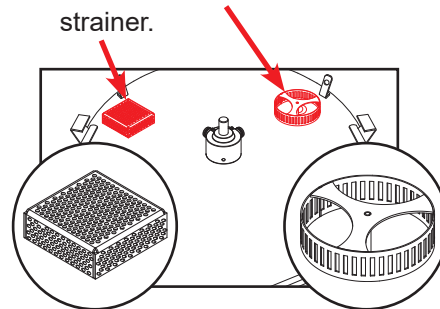

4. Insert middle of bottom wash arm into support bracket.

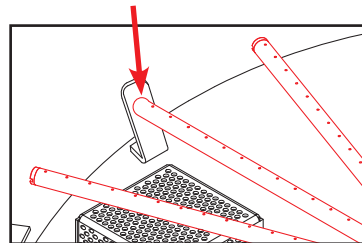

5. Push bottom wash arm onto manifold.

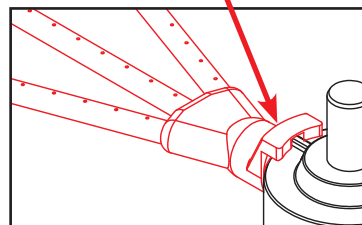

Top stop cap opening has a guide tab which allows the opening to easily be located during arm install.

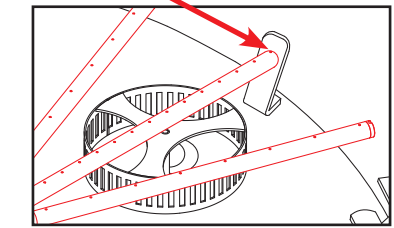

7. Push bottom rinse arm onto manifold.

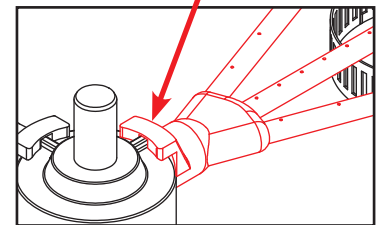

8. Replace bottom stop cap.

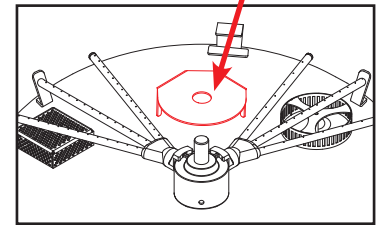

NOTICE

Stop cap must be oriented as shown!

9. Insert middle of top wash arm into support bracket.

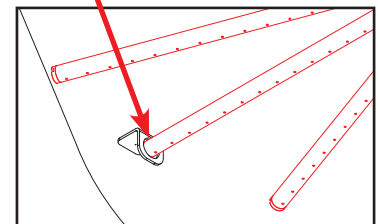

10. Push top wash arm onto manifold.

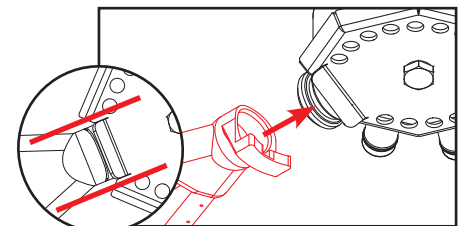

Align bottom of arm with guide tab on stop cap for easy install.

**AFTER
CLEANING**

11. Turn top stop cap counter-clockwise until opening aligns with wash arm location on manifold.

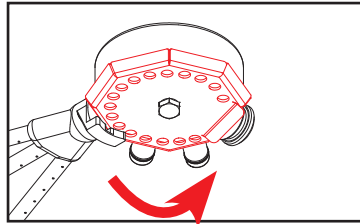

12. Insert middle of top rinse arm into support bracket.

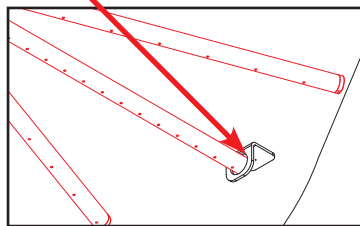

13. Push top rinse arm onto manifold.

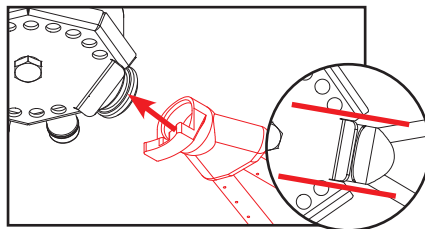

Align bottom of arm with guide tab on stop cap for easy install.

14. Turn top stop cap counter-clockwise until the opening does NOT align with either arm.

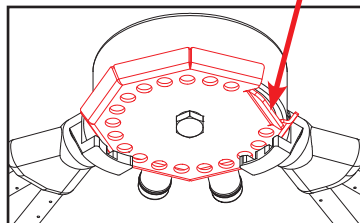

15. Replace carousel.

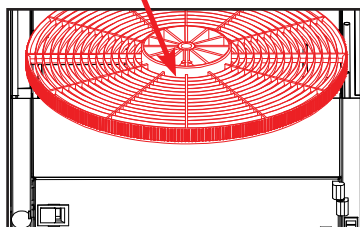

16. Replace rack cylinder.

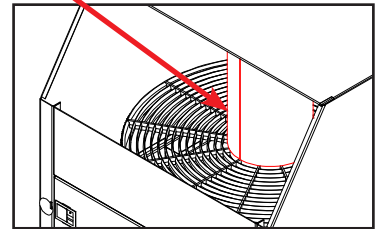

17. Replace drain boards.

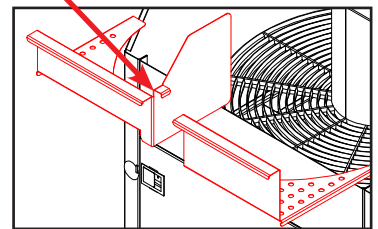

18. Replace curtain.

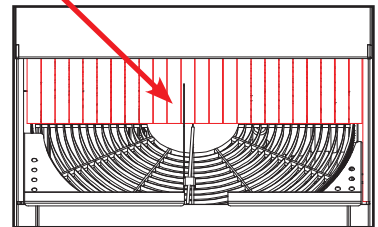

19. Replace drain stopper.

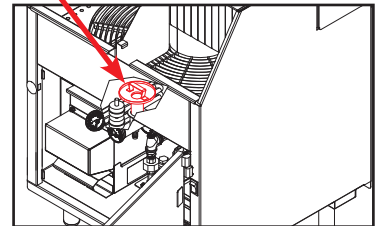

20. Replace wash strainer.

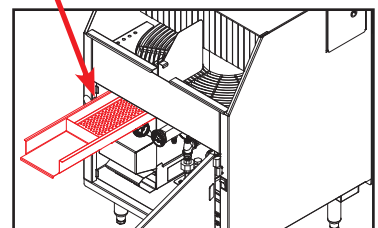

21. Use stainless steel polish to clean and protect outside of machine.

Top stop cap opening has a guide tab which allows the opening to easily be located during arm install.

DETERGENT CONTROL

Detergent usage and water hardness are two factors that contribute greatly to how efficiently this machine will operate. Using detergent in the proper amount can become a source of substantial savings. A qualified water treatment specialist can determine what is needed for maximum efficiency from the detergent.

1. Hard water greatly affects the performance of the machine, causing the amount of detergent required for washing to increase. If the machine is installed in an area with hard water, water treatment equipment should be installed.
2. Deposited solids from hard water can cause spotting that will not be removed with a drying agent. Treated water will reduce this occurrence.
3. Treated water might not be suitable for use in other areas of operation and it might be necessary to install a water treatment unit for the water going to the machine only. Discuss this option with a qualified water treatment specialist.
4. Operators should be properly trained on how much detergent is to be used per cycle. Meet with a water treatment specialist and detergent vendor to discuss a complete training program for operators.
5. This machine requires chemicals be provided for proper operation and sanitization. Contact a chemical supplier with any questions.
6. Water temperature is an important factor in ensuring that the machine functions properly, and the machine's data plate details what the minimum temperatures must be. If minimum requirements are not met, there is a possibility that dishes will not be clean or sanitized.
7. Instruct machine operators to observe the required temperatures and to report when they fall below the minimum allowed. A loss of temperature can indicate a larger problem.

**DELIMING**

In order to maintain the machine at its optimum performance level, lime and corrosion deposits must be removed. The frequency for deliming will be based on water conditions. A deliming solution is available from your chemical supplier. Read and follow all instructions on the label.

1. Disconnect the detergent pump.
2. Drain and refill the wash tank.
3. Add deliming solution per supplier's instructions.
4. Run machine the period of time recommended by chemical supplier.
5. Wait five minutes, then inspect the inside of the machine. If the machine is not delimed, run again.
6. Run two cycles to remove residual deliming solution.

PREVENTATIVE MAINTENANCE

The manufacturer highly recommends that any maintenance and repairs not specifically discussed in this manual be performed only by **QUALIFIED SERVICE PERSONNEL**. Performing maintenance on your machine may void your warranty, lead to larger problems, or even cause harm to the operator.

By following the operating and cleaning instructions in this manual, you should get the most efficient results from your machine. As a reminder, here are some steps to take to ensure that you are using the machine the way it was designed to work:

**CAUTION!**

Do NOT beat strainers to remove debris!

1. Ensure that the water temperatures match those listed on the machine data plate. There can be a variety of reasons why your water temperature could be too low.
2. Ensure that all strainers are clean and securely in place before operating the machine. When cleaning out strainers, do NOT beat them on waste cans. Wipe out strainers with a rag and rinse under a faucet if necessary. Use a toothpick to dislodge any stubborn debris.
3. Ensure that all wash and rinse arms are secure in the machine before operating.
4. Ensure that the drain stopper is installed correctly (seated vertically in the center of the wash sump).
5. Remove as much soil from glasses as possible before loading onto carousel.
6. Do not overfill the carousel.
7. Ensure that glasses are placed upside-down on the carousel.
8. Ensure that all chemicals being injected into machine have been verified at the correct concentrations.
9. Clean the machine at the end of every workday per the Shutdown and Cleaning and After Cleaning sections of this manual.
10. Follow all safety procedures, whether listed in this manual or put forth by local, state, or national codes/regulations.



WARNING! Inspection, testing, and repair of electrical equipment should only be performed by qualified service personnel. Certain procedures in this section require electrical tests or measurements while power is applied to the machine. Exercise extreme caution at all times. If test points are not easily accessible, disconnect power, attach test equipment, and reapply power to test. When replacing electrical parts, disconnect power at source circuit breaker.

OBSERVATION	POSSIBLE CAUSE	REMEDY
Machine will not run; no voltage at wash relay terminals L1 and T1.	<ol style="list-style-type: none"> 1. Electrical power not installed to machine, service (main) disconnect off. 2. Branch circuit breaker tripped or fuse is blown. 3. Loose or broken connection to dish machine. 	<ol style="list-style-type: none"> 1. Ensure electrical wiring is run to machine and service (main) disconnect is on. 2. Reset or replace as required. Have an electrician check machine amp draw if problem recurs. 3. Tighten, replace, or repair as required.
Machine cycles continuously.	<ol style="list-style-type: none"> 1. Limit switch actuator is loose or has fallen off. 2. Faulty limit switch. 	<ol style="list-style-type: none"> 1. Reassemble/bend metal lever if necessary. 2. Replace switch.
Machine will not fill; other functions work.	<ol style="list-style-type: none"> 1. No water supply to machine. 2. Faulty hot water solenoid valve diaphragm or coil. 3. Faulty float switch. 	<ol style="list-style-type: none"> 1. Ensure that water is hooked-up properly to machine and is turned on. 2. Replace diaphragm and clean-out valve. Measure continuity on coil; if there is none, replace the coil. 3. Ohm-out the switch to ensure that upper and lower floats are working. If not, check float wiring to see if it is correct; if so, replace float.
Machine fills continuously, even with no power to the machine.	<ol style="list-style-type: none"> 1. Solenoid valve jammed/stuck in the open position. 2. Faulty float switch. 	<ol style="list-style-type: none"> 1. Check diaphragm and coil; replace as required. 2. Ohm-out the switch to ensure that upper and lower floats are working. If not, check float wiring to see if it is correct; if so, replace float switch.



WARNING! Inspection, testing, and repair of electrical equipment should only be performed by qualified service personnel. Certain procedures in this section require electrical tests or measurements while power is applied to the machine. Exercise extreme caution at all times. If test points are not easily accessible, disconnect power, attach test equipment, and reapply power to test. When replacing electrical parts, disconnect power at source circuit breaker.

OBSERVATION	POSSIBLE CAUSE	REMEDY
Wash motor does not run; other functions work.	<ol style="list-style-type: none"> Loose wire connection to limit switch or relay. Faulty pump motor. Mechanical binding in the pump. High or low voltage problem. Faulty limit switch. 	<ol style="list-style-type: none"> Tighten wires. Replace pump motor. If motor has correct incoming voltage and the overload is tripping, repair or replace the pump. Check voltage at motor and at power terminal block. Ensure it meets the electrical voltage specifications for the machine. Replace limit switch.
Wash motor runs continuously.	<ol style="list-style-type: none"> Wash relay stuck closed. 	<ol style="list-style-type: none"> Turn machine off. If wash relay does not release, replace.
Low water pressure.	<ol style="list-style-type: none"> Drain clogged. Defective drain valve. 	<ol style="list-style-type: none"> Remove obstruction. Replace.
No indication of pressure.	<ol style="list-style-type: none"> Water level is too low. Wash arms clogged. Obstruction in pump housing. O-ring at wash tank drain cut or missing. 	<ol style="list-style-type: none"> Ensure that incoming water line pressure meets the requirements on machine data plate. Remove wash arms and clean. Disassemble and clear. Replace.
Low wash water pressure at wash arm spray nozzles.	<ol style="list-style-type: none"> Pump impeller worn or broken. Clogged jets in wash arms. Float stuck on float switch. Water level too low in the wash tank. 	<ol style="list-style-type: none"> Replace pump. Clean out wash arms. Remove, clean, and reinstall float switch. Ensure that the incoming water line flow pressure meets the requirements on the machine data plate.



WARNING! Inspection, testing, and repair of electrical equipment should only be performed by qualified service personnel. Certain procedures in this section require electrical tests or measurements while power is applied to the machine. Exercise extreme caution at all times. If test points are not easily accessible, disconnect power, attach test equipment, and reapply power to test. When replacing electrical parts, disconnect power at source circuit breaker.

OBSERVATION	POSSIBLE CAUSE	REMEDY
Machine keeps tripping service breaker.	<ol style="list-style-type: none"> 1. Power supply shorted to ground. 2. Pump impeller jammed. 3. Wash pump motor faulty. 4. Service breaker too small. 	<ol style="list-style-type: none"> 1. Check for loose wires/burned connection. Replace or repair as required. 2. Disassemble and remove obstruction. 3. Check motor voltage and amp draw. 4. Replace with correct-sized breaker.
Machine will not hold water.	<ol style="list-style-type: none"> 1. Drain stopper not in place. 2. Drain fitting O-ring cut or missing. 3. Drain stopper bent or deformed. 	<ol style="list-style-type: none"> 1. Set drain stopper correctly in drain. 2. Replace O-ring. 3. Replace.
Sanitizer pump runs continuously.	<ol style="list-style-type: none"> 1. Shorted prime switch. 2. Faulty speed control board. 	<ol style="list-style-type: none"> 1. If there is not line voltage between BLACK/YELLOW and ORANGE/BLUE wires to prime switch, replace. 2. Check operation of board. If not working properly, replace.
Sanitizer pump does not run during cycle, but runs when primed; even when turntable is off.	<ol style="list-style-type: none"> 1. Loose or broken wire. 2. Faulty speed control board. 3. Faulty prime switch. 	<ol style="list-style-type: none"> 1. Replace or tighten. 2. Check operation of board. If not working properly, replace. 3. Check continuity through each pole of the speed control board. If it fails, replace the speed control board.
Prime switch does not activate sanitizer pump.	<ol style="list-style-type: none"> 1. Faulty prime switch. 2. Loose wire to prime switch. 	<ol style="list-style-type: none"> 1. With the prime switch in the prime position, check for voltage between BLACK/YELLOW and ORANGE/BLUE wires. If there is line voltage, replace switch. 2. Tighten wire connection.



WARNING! Inspection, testing, and repair of electrical equipment should only be performed by qualified service personnel. Certain procedures in this section require electrical tests or measurements while power is applied to the machine. Exercise extreme caution at all times. If test points are not easily accessible, disconnect power, attach test equipment, and reapply power to test. When replacing electrical parts, disconnect power at source circuit breaker.

OBSERVATION	POSSIBLE CAUSE	REMEDY
Sanitizer pump doesn't run during cycle or through prime switch.	<ol style="list-style-type: none"> Loose motor terminal wires. Faulty sanitizer pump motor. Faulty prime switch. 	<ol style="list-style-type: none"> Tighten connections. If you read line voltage at the sanitizer motor terminals during the sanitizer feed cycle, replace the motor. Check the continuity through each pole of the switch. If faulty, replace the speed control board.
Detergent not feeding but rinse-aid feeds okay.	<ol style="list-style-type: none"> Faulty speed control board. 	<ol style="list-style-type: none"> Check operation of board. If not working properly, replace.
Rinse-aid not feeding but detergent feeds okay.	<ol style="list-style-type: none"> Faulty speed control board. Defective hose or squeeze tube. 	<ol style="list-style-type: none"> Check operation of board. If not working properly, replace. Replace hose or squeeze tube as needed.
Wash heater does not work. (NOTE: <i>push wash heater contactor bar down and take amperage reading. Amps should be correct as stated on machine data plate</i>).	<ol style="list-style-type: none"> If no amp draw, check wash heater for continuity. Wash heater relay will not energize (no voltage at contactor coil). Low voltage problem. 	<ol style="list-style-type: none"> If open or shorted, replace the heater. If closed, replace the heater contactor. Check for continuity at wash thermostat. If open, replace. Check incoming voltage to ensure it meets the requirements on machine data plate.

CHEMICAL FEEDER PUMP MOTOR REPLACEMENT

These machines come equipped with chemical feeder pumps to ensure proper warewashing results. Occasionally, the motors operating these pumps might need replacing. The instructions provided here are for maintenance personnel only. Unauthorized persons should not attempt any of the steps contained in these instructions.



CAUTION! Many of the instructions and steps within this document require the use of tools. Only authorized personnel should ever perform any maintenance procedure on the machine!

PREPARATION

- Power must be secured to the machine at the service breaker. Tag or lock-out the service breaker to prevent accidental or unauthorized energizing of the machine.



- Ensure that incoming water to the machine is secured either by use of a shut-off valve or disconnecting the incoming water line.
- The machine must be drained completely with the drain stopper removed.

TOOLS REQUIRED

- Phillips Screwdriver
- Needle-nose Pliers
- Wire Cutters
- Wire Strippers
- Crimping Tool

IMPORTANT NOTES

- Read these instructions thoroughly before attempting this maintenance task. Become familiar with the parts and what actions need to be taken. This will save time in the long run!
- These instructions show steps on only one of the three motors. However, the steps are the same for each one.

STEPS

1. Remove the front door.
2. Remove the electrical box cover with the phillipshead screwdriver.



3. The cover must be laid-down close to the control box because of the attached wires. Be careful not to yank out or damage any of the wires as you move the cover.

CHEMICAL FEEDER PUMP MOTOR REPLACEMENT

4. Determine which motor you wish to replace, or which one you wish to start with. Trace the wire leading from the motor to its corresponding prime switch. Trace the other wire from the motor to determine where it is connected.
5. With the needle-nose pliers, remove the motor wire from the prime switch, being careful not to damage the prime switch in the process. (If the prime switch is damaged, it will need to be replaced.)

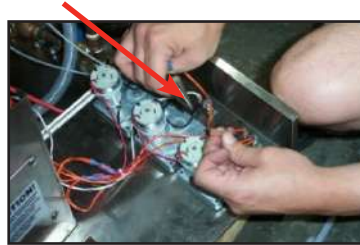

6. Turn the cover over and using the phillips screwdriver, remove the cover to the pump requiring a motor change.



7. With the cover removed, gently pull out the rubber tube from inside the pump.



8. Remove the roller by pulling it off of the shaft.



9. Using the phillips screwdriver, remove the four mounting screws for the motor.



CHEMICAL FEEDER PUMP MOTOR REPLACEMENT

10. Once the screws are removed, the motor should drop away.



11. Cut away any tie-wraps that are holding the power wires and remove the motor.
12. Take your new motor and attach new terminals to the wires as required.
13. Re-mount the motor to the pump.
14. Place the roller and the rubber tube back in the pump casing. Place the pump cover back on and tighten-down with the four screws previously removed.
15. Re-attach the power wire and the wire for the priming switch.
16. Put the cover back on the control box and secure with the two screws previously removed.
17. Ensuring that all non-essential personnel are clear of the area and restore power to the machine. Turn the machine on. Using the priming switch, verify that the feeder pump operates and pumps fluid.
18. Replace the front door.



NOTICE *Work performed on machines by unauthorized or unqualified personnel may void the warranty. Before beginning this or any other maintenance on a machine under warranty, you should contact a qualified service agency.*

WASH TANK HEATER REPLACEMENT



CAUTION! Many of the instructions and steps within this document require the use of tools. Only authorized personnel should ever perform any maintenance procedure on the machine!

These machines come equipped with heaters to ensure proper warewashing results. Occasionally, these components might need replacing. The instructions provided here are for maintenance personnel only. Unauthorized persons should not attempt any of the steps contained in these instructions.

PREPARATION

- Power must be secured to the machine at the service breaker. Tag or lock-out the service breaker to prevent accidental or unauthorized energizing of the machine.



- Ensure that incoming water to the machine is secured either by use of a shut-off valve or disconnecting the incoming water line.
- The machine must be drained completely with the drain stopper removed.

TOOLS REQUIRED

- 3/8" Nutdriver
- Ratchet
- 1/2" Socket/Wrench
- 3/8" Socket/Wrench
- Torque Wrench
- Amp Meter
- Phillips Screwdriver

IMPORTANT NOTES

- Read these instructions thoroughly before attempting this maintenance task. Become familiar with the parts and what actions need to be taken. This will save time in the long run!

STEPS

1. Remove the front door.
2. Remove the heater box cover with the 3/8" nutdriver. Set the cover and hardware to the side.



**WASH TANK HEATER
REPLACEMENT**

3. Remove the lower strainer.



4. Remove the ELAN thermostat using a phillips screwdriver. Either unplug the wires or cut the wire-tie and let the thermostat hang down out of the way.



5. Remove the thermostat bracket with the 3/8" nutdriver.



6. Remove the upper (wash) strainer. Set both strainers to the side where they will not be damaged or present a trip hazard.



7. Using the 3/8" nutdriver, remove the nuts securing the heater wires to the heater. Then carefully pull the wires out of the way.



**WASH TANK HEATER
REPLACEMENT**

8. Using a 1/2" socket or wrench, remove the heater mounting nuts.



9. Removing the heater might require that you reach into the wash tank, grasp it, and give it a push out of the wash tank.



10. Once the heater is pushed away from the tank wall, pull it out with your hands.



11. Remove the old heater gasket and throw away.
12. Apply the new heater gasket.



13. Take the new heater and slide it through the hole in the wash tank and line it up so the wash tank studs fit in the holes on the heater flange (Step 10 in reverse).
14. Place the mounting nuts and lockwashers on the studs and secure them with a 1/2" socket or wrench (Step 8 in reverse).



WASH TANK HEATER REPLACEMENT

15. Place the heater wires on the heater and tighten the nuts down using the 3/8" nutdriver (Step 7 in reverse).



16. Using the torque wrench or a torque nutdriver (if available) torque the nuts holding the wires, jumpers, and bus bars to 16 in-lbs.
17. Replace the thermostat bracket using the 3/8" nutdriver (Step 5 in reverse).



18. Replace the ELAN thermostat using a phillips screwdriver (Step 4 in reverse). If you unplugged the wires, reconnect them per the machine schematic on the back of the door. If not, move to the next step.



19. Replace the upper and lower strainers.
20. Ensuring that all non-essential personnel are clear of the area, place the drain stopper back in the wash tank and restore power and water to the machine. Turn the machine on and allow it to fill normally.
21. Verify that there are no leaks around the heater. If there are, attempt to tighten it down (with power secured to the machine at the service breaker to prevent injury) as the tank will change shape slightly as it heats up.
22. Use the amp meter to take readings off of the power lines to the heater, verifying they match the machine data plate. Be careful not to yank out or damage any of the wires as you move the cover.
23. Wait until the heater contactor kicks out (meaning that the tub has reached the appropriate temperature) and allow the machine to operate approximately ten minutes to verify that there are no leaks and that the heater is maintaining the tank temperature.

WASH TANK HEATER REPLACEMENT

24. Replace the heater cover (Step 2 in reverse).



25. Replace the front door.

AFTER MAINTENANCE ACTIONS

- Service personnel might want to drain the machine and allow it to cool down. Secure power to the machine at the service breaker and then verify the torque of all fasteners covered in this instruction.



NOTICE *Work performed on machines by unauthorized or unqualified personnel may void the warranty. Before beginning this or any other maintenance on a machine under warranty, you should contact a qualified service agency.*

THERMOSTAT REPLACEMENT



CAUTION! Many of the instructions and steps within this document require the use of tools. Only authorized personnel should ever perform any maintenance procedure on the machine!

These machines come equipped with a thermostat to ensure proper warewashing results. Occasionally, this component might need replacing. The instructions provided here are for maintenance personnel only. Unauthorized persons should not attempt any of the steps contained in these instructions.

PREPARATION

- Power must be secured to the machine at the service breaker. Tag or lock-out the service breaker to prevent accidental or unauthorized energizing of the machine.



- Ensure that incoming water to the machine is secured either by use of a shut-off valve or disconnecting the incoming water line.
- The machine must be drained completely with the drain stopper removed.

TOOLS REQUIRED

- 3/8" Nutdriver
- 7/16" Nutdriver
- 7/16" Wrench
- Needle-nose Pliers
- Phillips Screwdriver

IMPORTANT NOTES

- Read these instructions thoroughly before attempting this maintenance task. Become familiar with the parts and what actions need to be taken. This will save time in the long run!

STEPS

1. Remove the front door.
2. Remove the heater box cover with the 3/8" nutdriver. Set the cover and hardware to the side.



THERMOSTAT REPLACEMENT

- Using the pair of needle-nose pliers (if necessary), disconnect the terminals from the thermostat probe. Be careful not to damage the terminals or the wires or they will have to be replaced.



- Unplug all of the terminals/wires connected to the ELAN thermostat.



- Remove the ELAN thermostat using a phillips screwdriver.



- Remove the thermostat bracket with the 3/8" nutdriver.



- Use the 7/16" wrench to loosen and remove the imperial brass fitting.



THERMOSTAT REPLACEMENT

8. Pull the thermostat probe out of the wash tank.



9. Place the new thermostat probe in the new imperial brass fitting provided in your kit. Use the 7/16" wrench to tighten it down after getting the fitting hand-tight in the tank.
10. Replace the thermostat bracket with the 3/8" nutdriver (Step 6 in reverse).
11. Place the new ELAN thermostat on the bracket and secure it with the phillips screwdriver.
12. Reconnect the wires per the machine schematic on the back of the door.
13. Place the drain stopper back in the wash tank. Restore power and water to the machine. Then allow the machine to operate normally.
14. Verify the thermostat operates the heater contactor. Once you have determined the heater contactor is working, adjust the wash tank thermostat to ensure the temperature is maintained in accordance with the specifications on the machine data plate.
15. Replace the heater cover.
16. Replace the front door.



NOTICE *Work performed on machines by unauthorized or unqualified personnel may void the warranty. Before beginning this or any other maintenance on a machine under warranty, you should contact a qualified service agency.*

WASH MOTOR REPLACEMENT



CAUTION! Many of the instructions and steps within this document require the use of tools. Only authorized personnel should ever perform any maintenance procedure on the machine!

These machines come equipped with wash pumps with powerful motors to ensure proper warewashing results. Occasionally, these components might need replacing. The instructions provided here are for maintenance personnel only. Unauthorized persons should not attempt any of the steps contained in these instructions.

PREPARATION

- Power must be secured to the machine at the service breaker. Tag or lock-out the service breaker to prevent accidental or unauthorized energizing of the machine.



- Ensure that incoming water to the machine is secured either by use of a shut-off valve or disconnecting the incoming water line.
- The machine must be drained completely with the drain stopper removed.

TOOLS REQUIRED

- 3/8" Nutdriver
- 7/16" Nutdriver
- 7/16" Wrench
- Needle-nose Pliers
- Phillips Screwdriver

IMPORTANT NOTES

- Read these instructions thoroughly before attempting this maintenance task. Become familiar with the parts and what actions need to be taken. This will save time in the long run!

STEPS

1. To access the assembly, you need to get access to the rear of the machine. This might require that water, drain, and power lines be disconnected so that the machine can be moved for access.



**WASH MOTOR
REPLACEMENT**

- Using the 5/16" nutdriver, loosen the clamps on the suction hose.



- Using the same nutdriver, loosen the discharge hose where it connects to the tub weldment.



- Pull the discharge hose out and away from the tub.



- Remove the motor assembly mounting nuts using the 7/16" combination wrench.



- With the nuts removed, grasp the motor assembly and lift up on it to clear the mounting studs.



WASH MOTOR REPLACEMENT

7. Turn the motor so that you will have access to the wiring cover on the back. Be careful not to pull or yank too hard as the motor is still connected to the machine by way of the power lines.
8. Take the needle-nose pliers and remove the power wires from the terminals within the motor.
9. The motor should now be free. Replace with a new new motor by performing the removal steps in reverse.
10. Place the discharge hose assembly back on the discharge of the pump and tighten-down.
11. Lift the assembly into place within the machine, ensuring that the suction hose is attached and lines up. Move the assembly so the mounting bracket slides over the mounting studs. Position the assembly so that the suction hose is not kinked.
12. Replace and tighten-down the nuts securing the bracket to the frame.
13. Tighten the clamps for the suction hose.
14. Connect the discharge hose to the tub and tighten-down the hose clamp.

AFTER MAINTENANCE ACTIONS

Verify the operation of the new wash motor and pump assembly by running the machine for approximately 15 minutes. Check for leaks and correct as necessary.



NOTICE *Work performed on machines by unauthorized or unqualified personnel may void the warranty. Before beginning this or any other maintenance on a machine under warranty, you should contact a qualified service agency.*

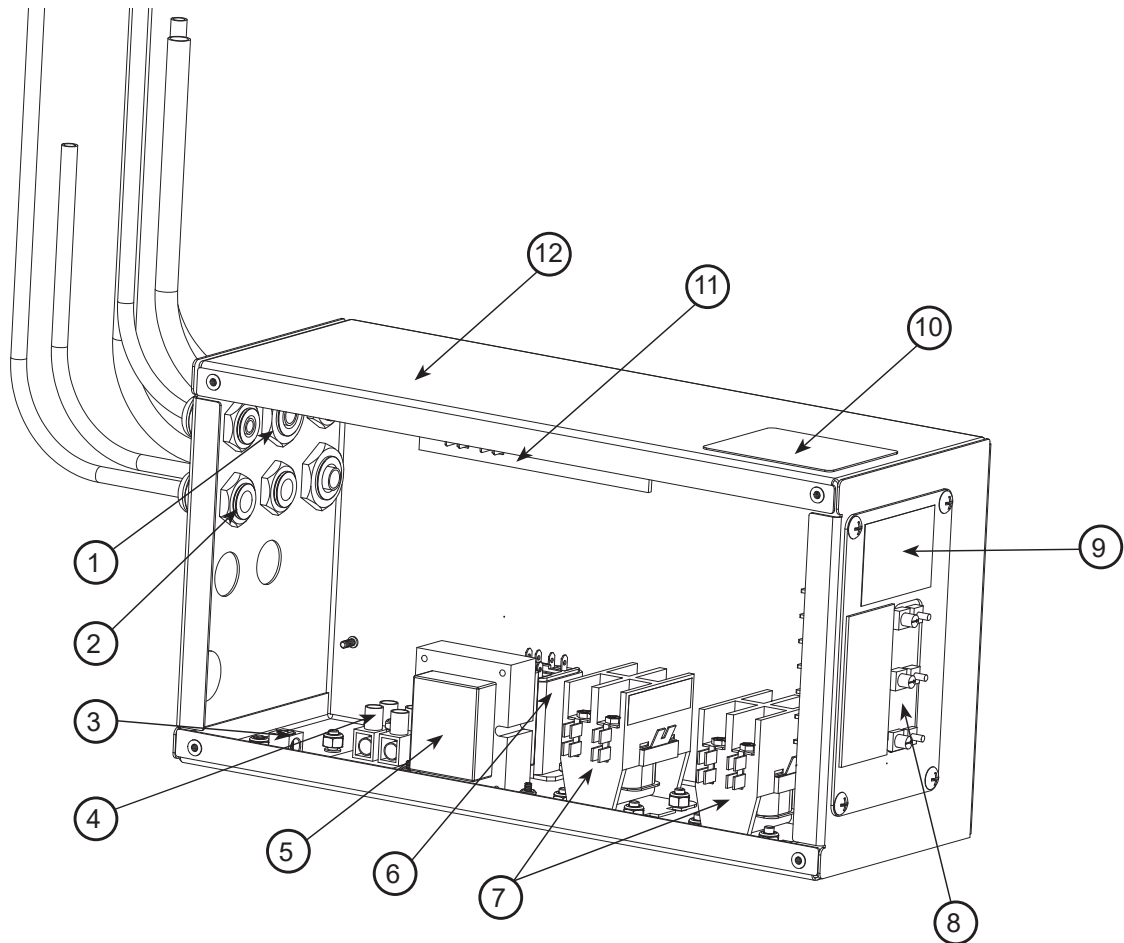

ITEM	QTY	DESCRIPTION	PART NUMBER
1	4	Fitting	05975-011-49-03
2	2	Fitting	05975-011-65-51
3	1	Ground Lug	05940-200-76-00
4	1	Separator	05940-500-09-61
5	1	Transformer	05950-002-16-78
6	1	Relay	05945-111-35-19
7	2	Contactors	05945-109-05-69
8	1	Access Panel	05700-003-55-38
9	1	Decal, Warning, Disconnect Power	09905-004-08-16
10	1	Decal, Caution	09905-011-68-99
11	1	Terminal Board	05940-002-78-97
12	1	Complete Assembly	05700-004-27-24

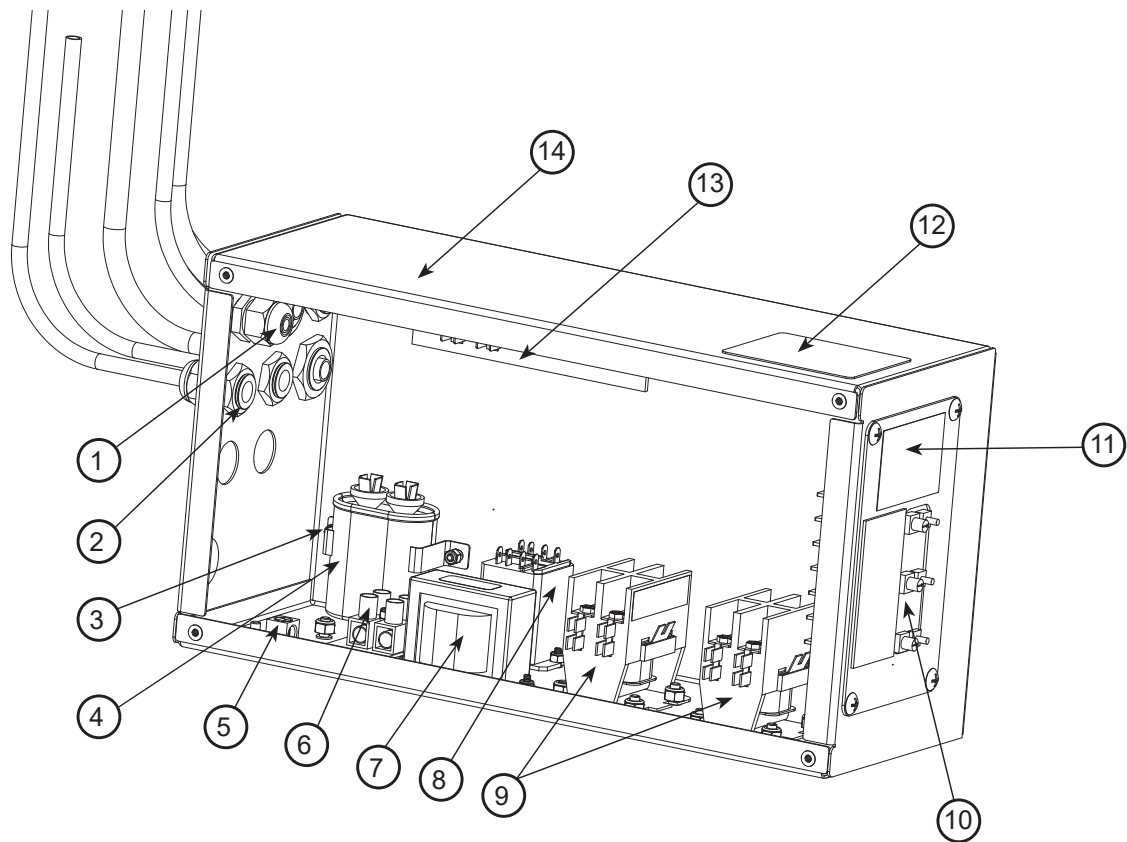

ITEM	QTY	DESCRIPTION	PART NUMBER
1	2	Fitting	05975-011-49-03
2	3	Fitting	05975-011-65-51
3	1	Bracket	05700-003-56-00
4	1	Capacitor	05910-003-43-01
5	1	Ground Lug	05940-200-76-00
6	1	Separator	05940-500-09-61
7	1	Transformer	05950-011-61-67
8	1	Relay	05945-002-47-74
9	2	Contactors	05945-002-74-20
10	1	Access Panel	05700-003-55-38
11	1	Decal, Warning, Disconnect Power	09905-004-08-16
12	1	Decal, Caution	09905-011-68-99
13	1	Terminal Board	05940-002-78-97
14	1	Complete Assembly	05700-003-55-37

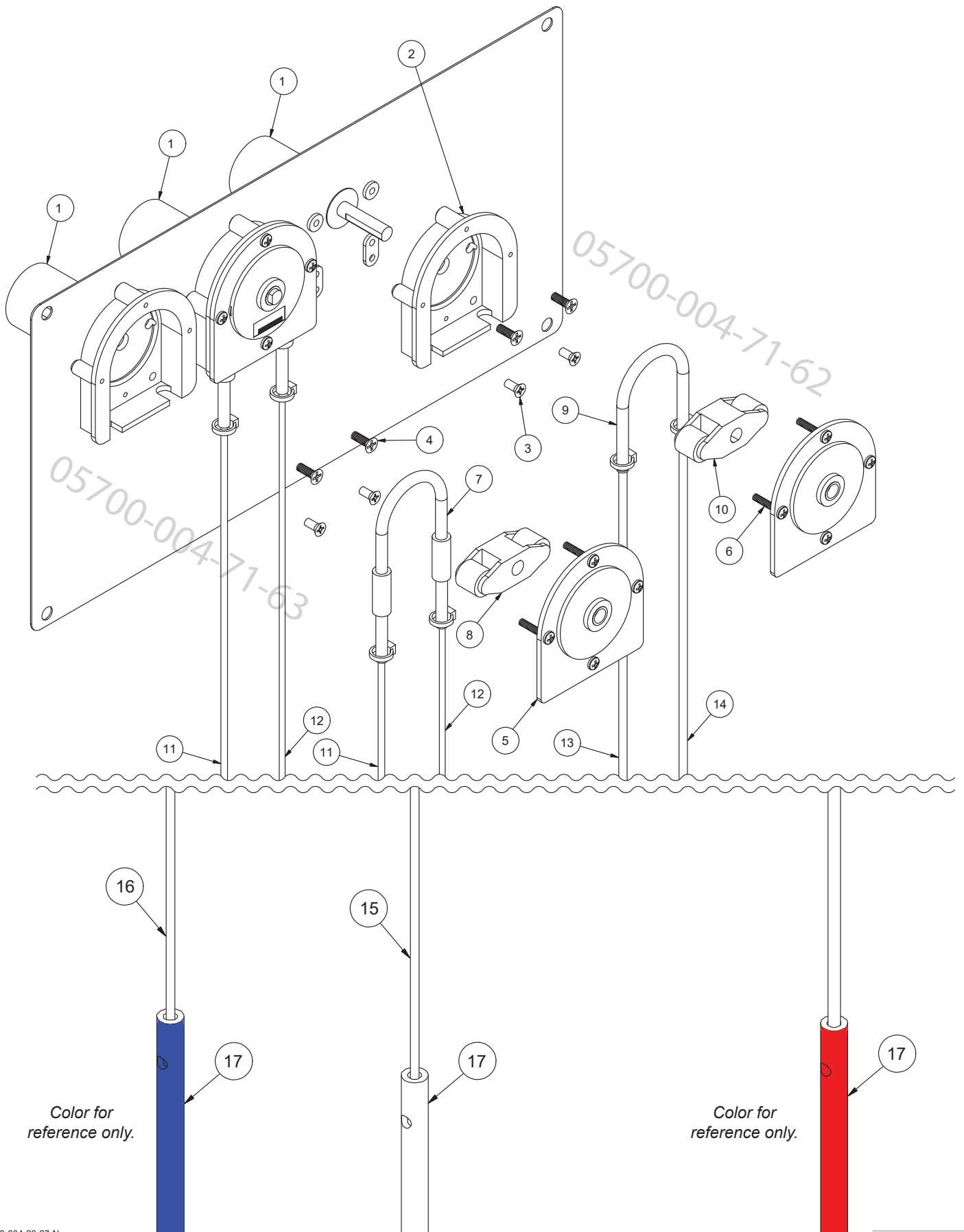

ITEM	QTY	DESCRIPTION	PART NUMBER
1	3	Motor, Peri-pump, 14 RPM	04320-011-63-33
2	3	Pump Housing, Rear	04320-111-37-09
3	6	Screw, 8-32 x 1/2"	05305-011-37-06
4	6	Screw, 8-32 x 3/8"	05305-011-37-07
5	3	Pump Housing, Cover	04320-111-37-08
6	9	Screw, 6-32 x 3/4"	05305-011-37-05
7	2	Tube, Squeeze	05700-011-65-21
8	2	Roller, Plastic	04320-111-65-27
9	1	Tube, Detergent Squeeze	05700-003-22-89
10	1	Roller, Plastic	04320-002-82-28
11	2	Tube, 1/8" x 60" Clear	05700-011-63-19
12	2	Tube, 1/8" x 35" Clear	05700-011-63-14
13	1	Tube, 1/4" x 60" Red	05700-011-63-18
14	1	Tube, 1/4" x 35" Red	05700-011-63-16
15	1	Tube, 1/4" x 15" Clear	05700-011-63-17
16	1	Tube, 1/4" x 15" Blue	05700-011-63-15
17	3	Tube Stiffener, 12"	05700-002-94-47

Complete Peri-pump Assembly, 1/8" Tube
Quantity 2 (Rinse-Aid and Sanitizer)
05700-004-71-63

Complete Peri-pump Assembly, 1/4" Tube
Quantity 1 (Detergent)
05700-004-71-62

Sanitizer Tube Replacement Kit
Contains Items 12, 13, 16, and 18
06401-003-61-21

Rinse-aid Tube Replacement Kit
Contains Items 12, 13, 17, and 18
06401-003-61-22

Detergent Tube Replacement Kit
Contains Items 14, 15, and 18
06401-003-61-23

Complete Bottom Inlet
Manifold Assembly
05700-003-60-49

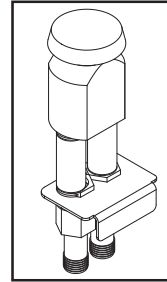
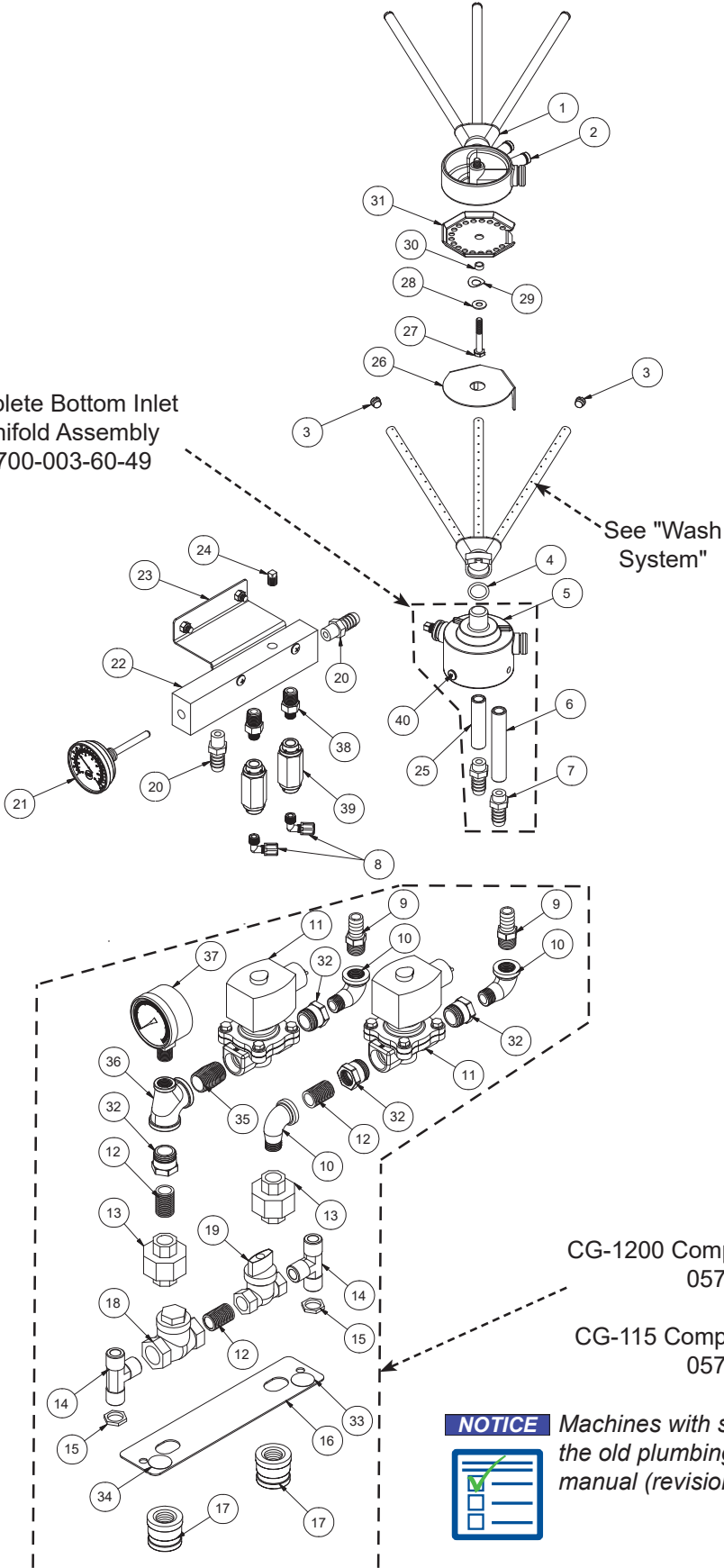

Vacuum Breaker Assembly
05700-003-55-31

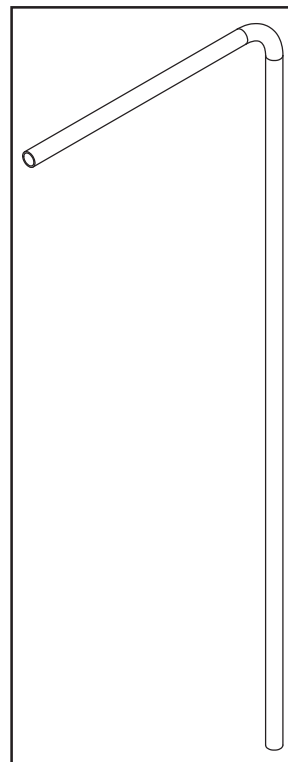

Rinse Tube
05700-003-49-32

CG-1200 Complete Plumbing Assembly
05700-004-59-38

CG-115 Complete Plumbing Assembly
05700-004-59-37

NOTICE Machines with serial numbers before 18J365663 have the old plumbing assembly. Click [here](#) to open the manual (revision M) which shows the old assembly.



ITEM	QTY	DESCRIPTION	PART NUMBER
1	2	Rinse Arm	05700-003-42-81
2	1	Top Manifold	09330-003-45-71
3	6	Rinse Arm End-cap	05700-003-55-57
4	2	Rinse Arm O-ring	05330-011-74-55
5	1	Bottom Manifold	09330-003-45-67
6	1	Bottom Manifold Inlet	04710-003-60-46
7	2	Adapter, 1/2" Barb x 1/4"	04730-004-55-02
8	2	Elbow, 90-degree 1/8" x 1/8"	85635332
9	2	Fitting, 3/8" NPT x 1/2" Barbed	04730-002-18-54
10	3	Elbow, 3/8" 90-degree Street	04730-002-15-36
11	2	Solenoid Valve, CG-1200	04810-003-71-56
		Solenoid Valve, CG-115	04810-003-71-55
12	3	3/8" Close Nipple	04730-002-18-00
13	2	Union, 3/8" NPT Straight Brass	04730-003-60-57
14	2	Tee, 3/8" x 3/8" x 3/8" MNPT	04730-011-61-53
15	2	Jam Nut	05310-011-61-45
16	1	Mounting Plate	05700-003-60-21
17	2	Coupling, 1/2" FNPT x 3/8" FNPT	04730-011-61-52
18	1	Check Valve, 3/8" FNPT	04820-011-61-56
19	1	Ball Valve, 3/8" FNPT	04820-011-61-58
20	2	Fitting, 1/4" MNPT	04730-011-61-62
21	1	Thermometer	06685-111-35-30
22	1	Injection Manifold	05700-031-60-37
23	1	Bracket	05700-003-58-79
24	1	Plug, 1/4" Brass	04730-209-01-00
25	1	Bottom Manifold Inlet	05700-003-60-45
26	1	Stop Cap, Bottom	05700-004-58-32
27	1	Screw, 1/4-20 x 1 3/4" Hex Head	05305-274-10-00
28	1	Washer, 1/4-20	05311-174-01-00
29	1	Spring, Curved Disk	05311-004-58-34
30	1	Spacer	05700-000-29-40
31	1	Stop Cap, Top	05700-004-58-31
32	4	Reducer Bushing, 1/2" x 3/8"	04730-003-40-26
33	1	Decal, Red Dot	09905-011-65-46
34	1	Decal, Blue Dot	09905-011-65-47
35	1	Nipple, 1/2" Close Brass	04730-207-15-00
36	1	Fitting, Brass, Reducing Tee	04710-004-59-87
37	1	Pressure Gauge	06685-111-88-34
38	2	Reducer Nipple, 1/4" to 1/8"	04730-005-05-78
39	2	Check Valve, 1/8"	85244077
40	3	Screw, 10-32 x 1/2" with Sealing O-ring	05305-004-26-70

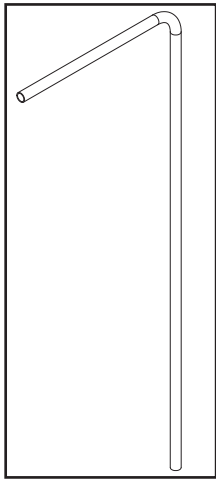

Wash Tube
05700-003-49-32

See "Rinse Assembly"

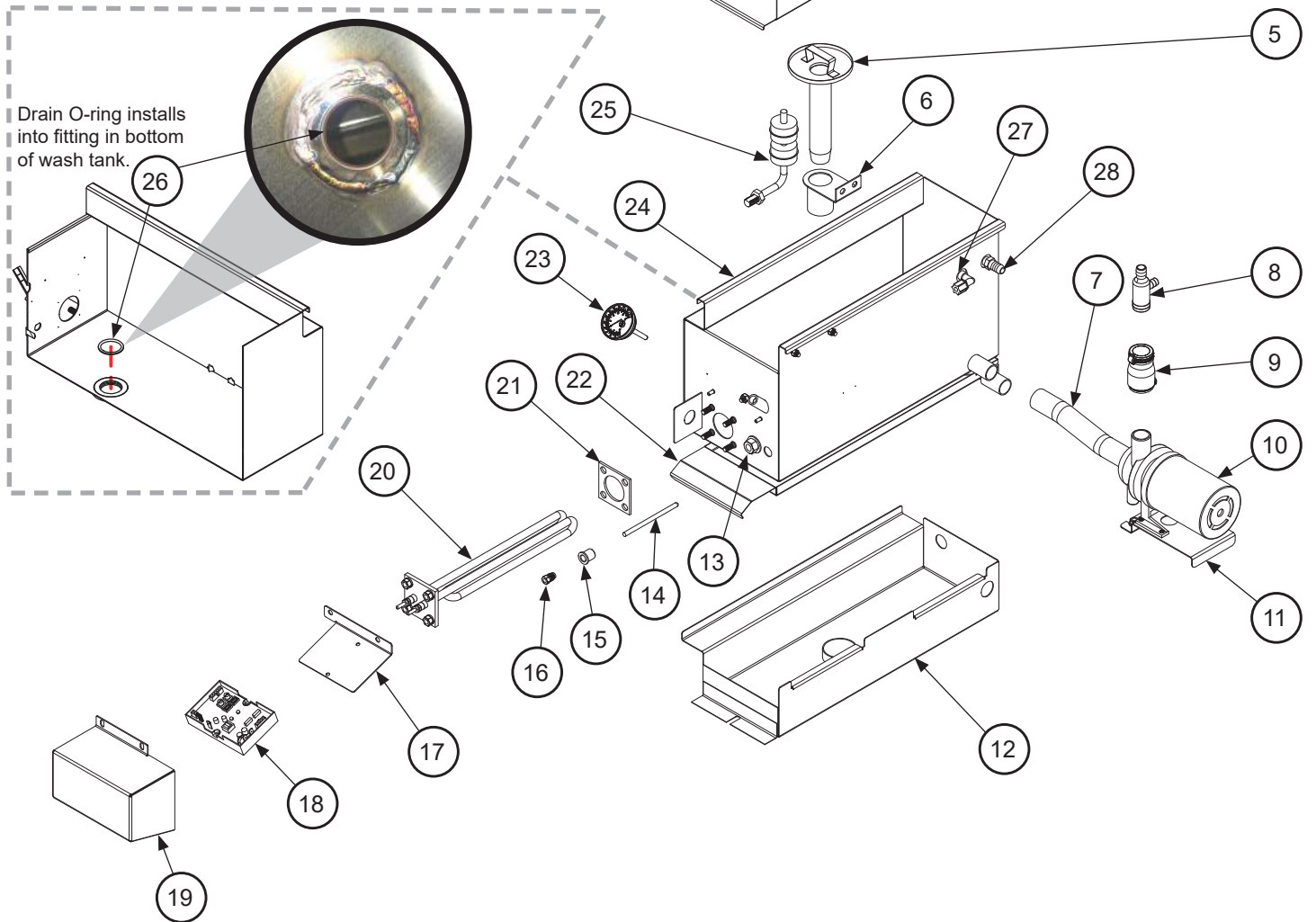

ITEM	QTY	DESCRIPTION	PART NUMBER
1	2	Wash Arm	05700-003-42-83
2	6	Wash Arm End-cap	05700-003-55-57
3	2	O-ring, 13/16" OD	05330-011-74-55
4	1	Wash Tank Strainer	05700-021-61-78
5	1	Drain Stopper	05700-021-62-22
6	1	Support, Drain Stopper	05700-003-59-21
7	1	Pump Suction Hose	05700-003-60-25
8	1	Pump Hose Connector	04730-003-40-64
9	1	Pump Discharge Hose	05700-003-59-96
10	1	Wash Pump, Delta 1200	06105-003-44-22
		Wash Pump, Delta 115	06105-004-25-01
11	1	Bracket, Wash Pump	05700-003-56-41
12	1	Drain Weldment	05700-003-60-00
13	1	Hexnut, 1/2"-13 S/S	05310-011-72-58
14	1	Thermostat Probe	06685-004-17-26
15	1	Washer, 1/2" Flat	05311-011-71-93
16	1	Thermostat Probe Fitting	05310-924-02-05
17	1	Thermostat Bracket	05700-004-28-56
18 ¹	1	Thermostat, Electronic Dual	06685-004-17-27
19	1	Heater Cover	05700-004-28-55
20	1	Wash Heater, CG-1200	04540-021-61-66
		Wash Heater, CG-115	04540-004-25-61
21	1	Wash Heater Gasket	05330-011-61-34
22	1	Rinse Strainer	05700-021-61-79
23	1	Thermometer	06685-111-35-30
24	1	Wash Tank	05700-003-60-12
25	1	Float	06680-121-70-16
26	1	Drain O-ring	05330-400-05-00
27	1	Elbow, 1/4" x 1/4"	04730-111-48-87
28	1	Fitting, 1/4", 1/2" OD	04730-011-61-62
29	1	Tub Bottom Gasket, Foam (Not Shown)	05700-003-60-41

Optional Accumulator Tray Kit
06401-031-66-21

Click [here](#) or on the instructions icon for install instructions.



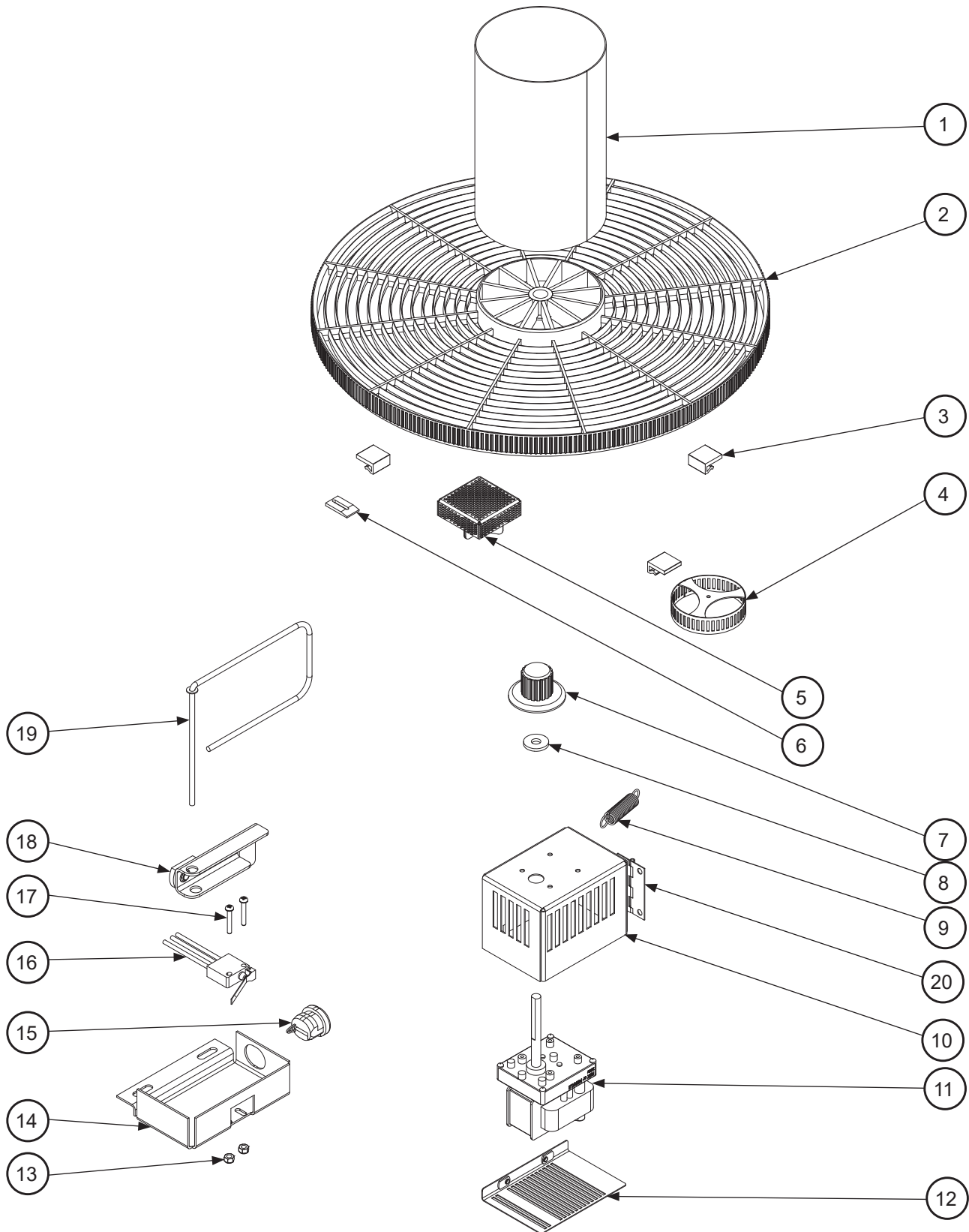

ITEM	QTY	DESCRIPTION	PART NUMBER
1	1	Cylinder	05700-003-49-10
2	1	Rack	09330-003-45-66
3	3	Guide Block	09330-003-51-17
4	1	Separator	05700-003-59-93
5	1	Strainer, Deflector	05700-004-35-13
6	1	Plate, Skid	09330-003-58-52
7	1	Drive Gear	09330-003-58-32
8	1	Washer	05330-003-41-75
9	1	Extension Spring	05340-005-11-64
10	1	Gear Motor Box	05700-003-48-87
11	1	Gear Motor, Delta 1200	06105-003-44-23
		Gear Motor, Delta 115	06105-004-26-30
12	1	Gear Motor Box Cover	05700-003-48-57
13	2	Lock Nut, 6-32	05310-373-03-00
14	1	Switch Mounting Bracket	05700-003-60-13
15	1	Liquidtite Fitting	05975-011-49-03
16	1	Limit Switch	05930-303-38-00
17	2	Limit Switch Mounting Screws	05305-171-10-00
18	1	Activator Weldment	05700-003-58-50
19	1	Limit Switch Actuator	05700-003-58-54
20	1	Hinge, Tilt Plate	05700-005-11-49

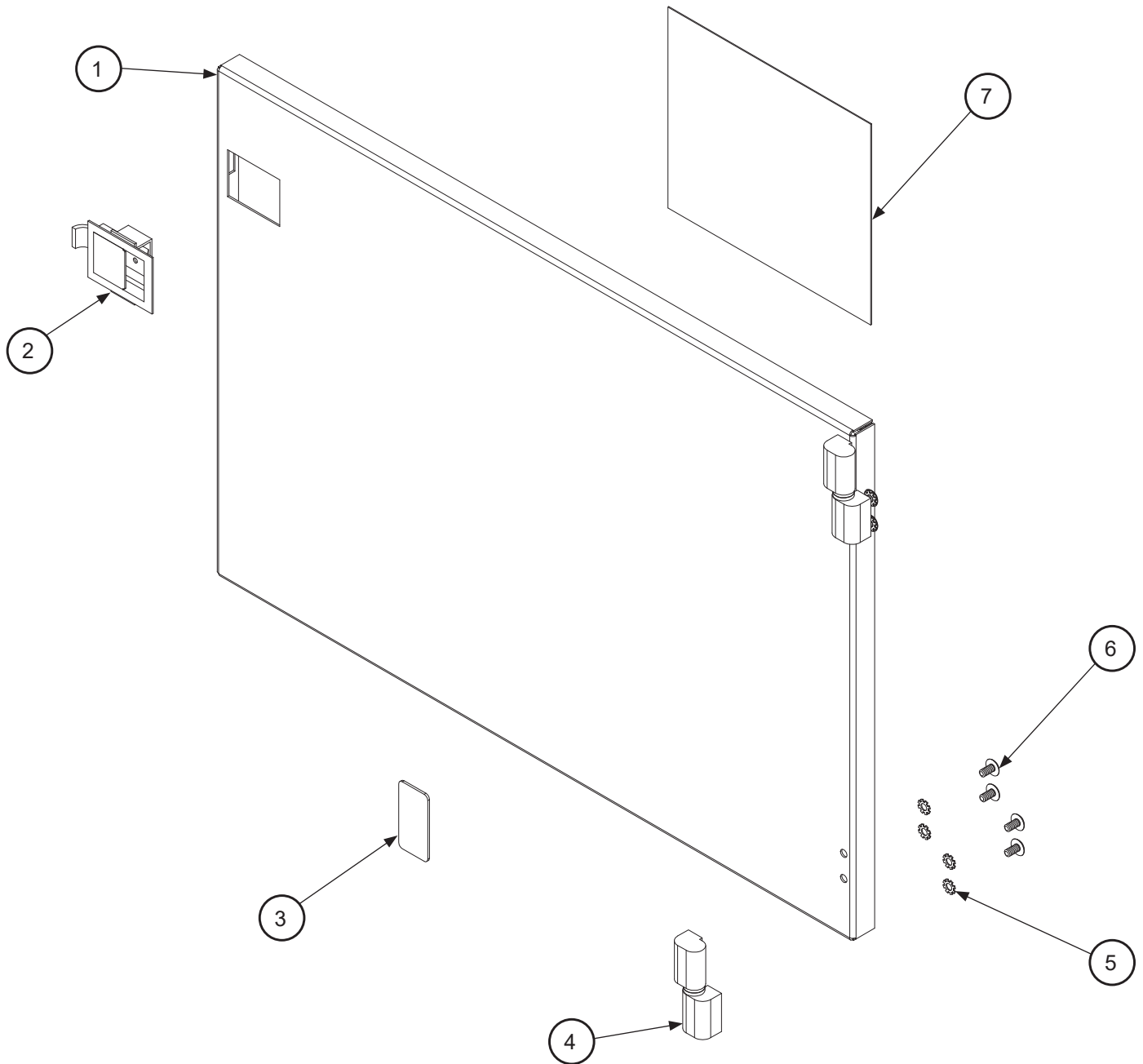

ITEM	QTY	DESCRIPTION	PART NUMBER
1	1	Door Weldment	05700-002-24-40
2	1	Handle, Door Glasswasher	05340-001-96-30
3	1	Decal - Off/Fill/On	09905-011-61-70
4	2	Hinge	05340-021-62-04
5	8	Starwasher, External Tooth	05311-273-02-00
6	8	Screw 10-24 X 3/8	05305-173-03-00
7	1	Decal, Operating Instructions	09905-021-64-88

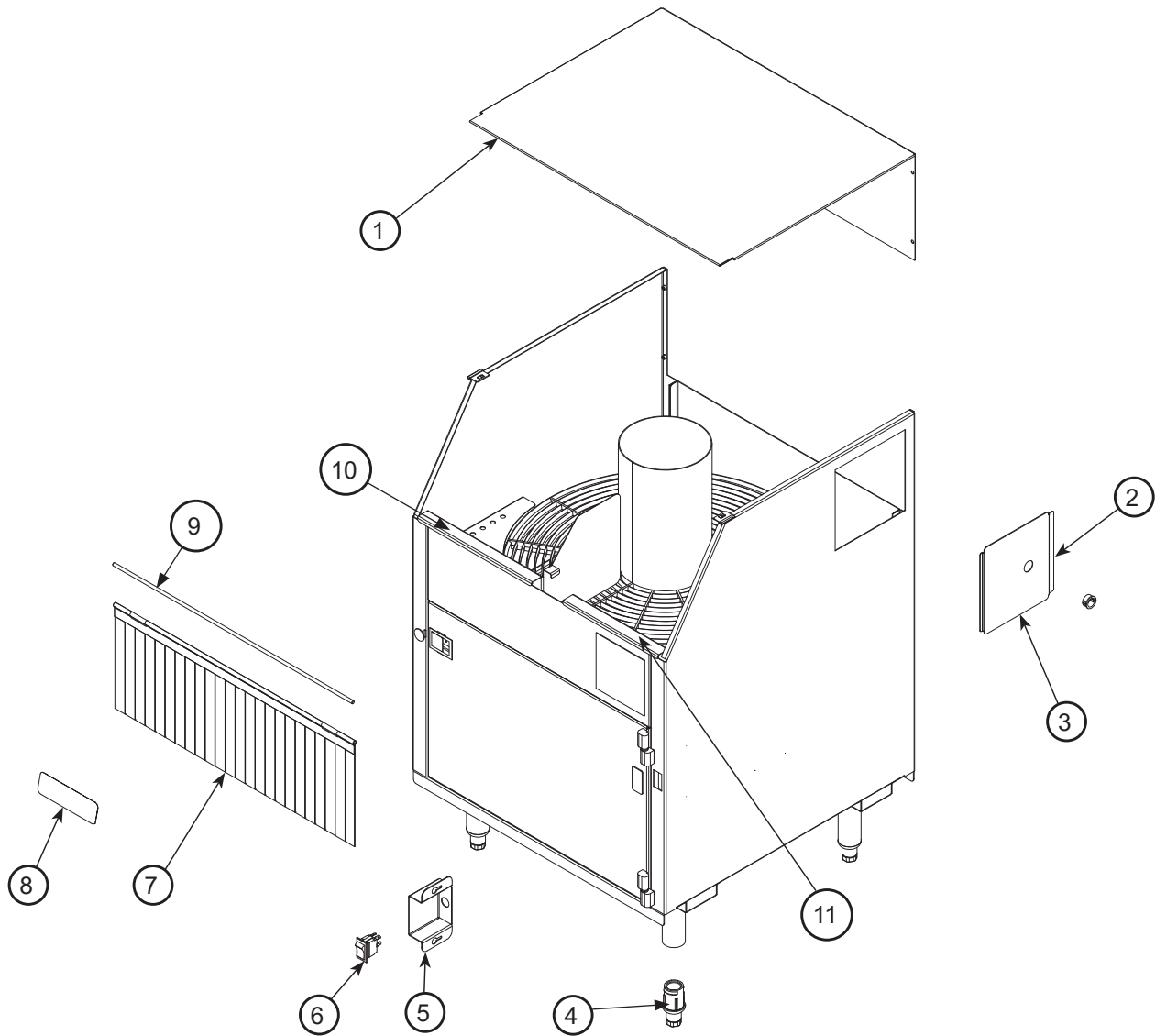

ITEM	QTY	DESCRIPTION	PART NUMBER
1	1	Outer Cover	05700-003-57-95
2	1	Bushing	05975-210-03-00
3	1	Access Cover	05700-003-58-73
4	4	Bullet Foot	05340-108-01-03
5	1	Switch Cover	05700-003-60-39
6	1	Power Switch	05930-011-61-69
7	1	Curtain	08415-003-60-35
8	1	Jackson Decal	09905-004-03-02
9	1	Curtain Rod	05700-003-60-38
10	1	Conveyor Guard, Left	05700-003-42-96
11	1	Conveyor Guard, Right	05700-003-42-91

SHOCK ABSORBER (WATER ARRESTOR) OPTION

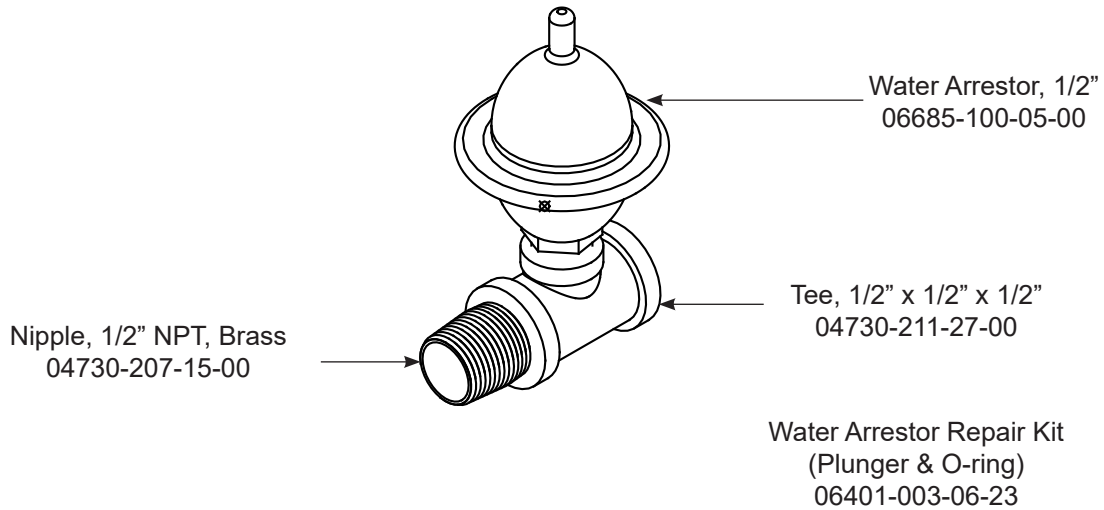

PRESSURE REGULATOR OPTION

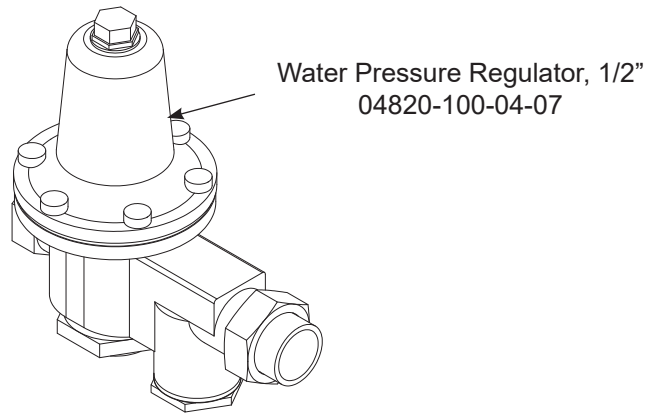

SCALE PREVENTION SYSTEM (SPS) OPTION

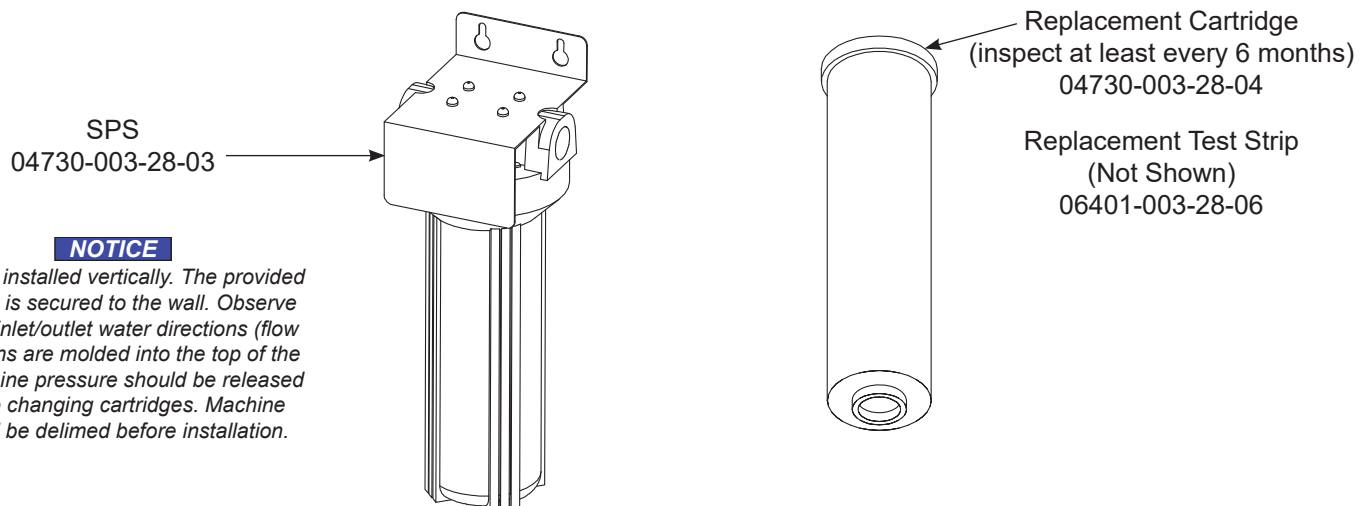

NOTICE

Must be installed vertically. The provided bracket is secured to the wall. Observe proper inlet/outlet water directions (flow directions are molded into the top of the head). Line pressure should be released before changing cartridges. Machine should be delimed before installation.

ROTARY GLASSWASHER SCHEMATIC

115/208/230 VOLTS, 50/60 Hz, 1-PHASE
(REFER TO DATA PLATE FOR MACHINE VOLTAGE)

N (WHT) (115V)
L2 (RED) (208/230V)

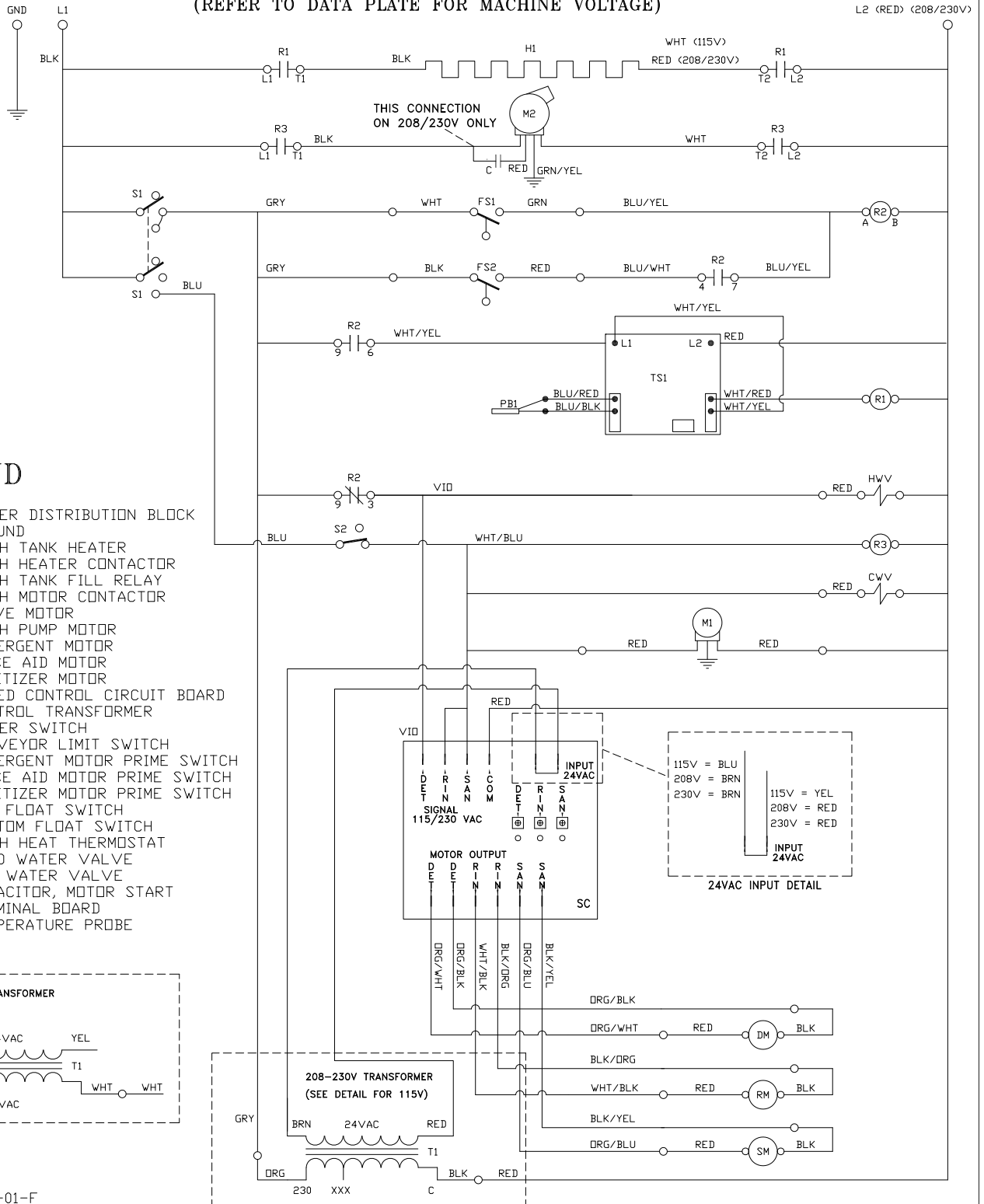

LEGEND

- L1 L2 POWER DISTRIBUTION BLOCK
- GND GROUND
- H1 WASH TANK HEATER
- R1 WASH HEATER CONTACTOR
- R2 WASH TANK FILL RELAY
- R3 WASH MOTOR CONTACTOR
- M1 DRIVE MOTOR
- M2 WASH PUMP MOTOR
- DM DETERGENT MOTOR
- RM RINSE AID MOTOR
- SM SANITIZER MOTOR
- SC SPEED CONTROL CIRCUIT BOARD
- T1 CONTROL TRANSFORMER
- S1 POWER SWITCH
- S2 CONVEYOR LIMIT SWITCH
- S3 DETERGENT MOTOR PRIME SWITCH
- S4 RINSE AID MOTOR PRIME SWITCH
- S5 SANITIZER MOTOR PRIME SWITCH
- FS1 TOP FLOAT SWITCH
- FS2 BOTTOM FLOAT SWITCH
- TS1 WASH HEAT THERMOSTAT
- CWV COLD WATER VALVE
- HWV HOT WATER VALVE
- C CAPACITOR, MOTOR START
- TB TERMINAL BOARD
- PB1 TEMPERATURE PROBE

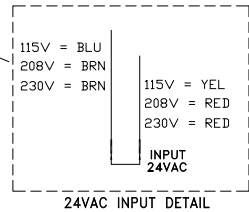
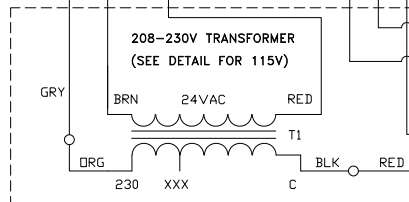
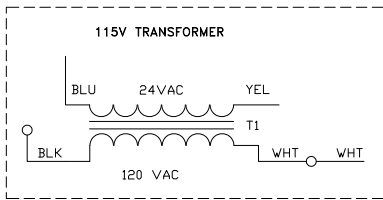

09905-003-56-01-F



Noble Warewashing • Lancaster, Pennsylvania
www.nobleproducts.biz
For Service Call 1-888-800-5672