

Continental

Refrigerator

INSTALLATION AND OPERATIONS MANUAL



Milk Coolers

Forced Air & Cold Wall

Please fill in the following information for your NEW unit, carefully read the instructions in this manual and file it for future reference.

MODEL NO. _____

SERIAL NO. _____

PURCHASED FROM _____

INSTALL DATE _____

1-800-523-7138

Continental Refrigerator
*A Division of National Refrigeration
& Air Conditioning Products, Inc.*
539 Dunksferry Road
Bensalem, PA 19020-5908
P 215-244-1400
F 215-244-9579
www.continentalrefrigerator.com

TABLE OF CONTENTS

	Page
Receiving Your New Model	3
Uncrating Your New Model	3
General Information and Important Operating Facts	3
Serial Data Tag.....	3
Installation and Location	4
Ventilation.....	4
Floor Loads.....	4
Floor Drain.....	4
Evaporator Condensate Removal.....	5
Cabinet Washout Drainage Hose	5
Initial Cleaning Procedure	6
Start-Up Procedure	6
Electrical Connections	6
Start-Up Checklist.....	7
Operation	7
Door Latch and Lid Lock	7
Latch Adjustment and Lock Replacement.....	7
Dial Thermometer and Calibration	7
Cold Wall Refrigeration System and Adjustment.....	8
Forced Air Refrigeration System and Adjustment.....	8
Removal of Top Assembly.....	9
Interior Accessories	9
Maintenance	10
Periodic Cleaning Procedure.....	10
General Preventative Maintenance.....	10
Care and Cleaning of Stainless Steel	11
Parts and Service	12
Placing a Service Call.....	12
Obtaining Replacement Parts Under Warranty	12
Obtaining Replacement Compressor Under Warranty.....	12
Optional Accessories	13
Digital Thermometer and Calibration.....	13
Troubleshooting and Servicing Guide	14
Wiring Diagrams	16
Limited Extended Protection Warranty	17

RECEIVING YOUR NEW MODEL

Congratulations on your purchase of Continental Refrigerator's superior milk cooler! When your shipment arrives, thoroughly examine the packaging for any punctures, dents, or signs of rough handling. It is in your best interest to partially remove or open the shipping container to examine the contents for any missing accessories or concealed damage which may have occurred during shipment. If the cabinet is damaged, it must be noted on the carrier's delivery slip or bill of lading. A Freight Claim must be filed with the shipping company. **FREIGHT DAMAGE IS NOT COVERED UNDER WARRANTY.**

UNCRATING YOUR NEW MODEL

The shipping carton should remain on your cabinet to protect against dents or scratches while transporting to the actual set-up location. Remove the shipping container only at the last possible moment by using a pry bar to take out all the staples from around the bottom of the crate. Slide the cardboard carton up and off the unit, being careful not to rub against the cabinet. Remove any accessories or boxes on the skid or in the cabinet. Dispose of all packaging materials properly.

Your milk cooler comes with the casters pre-installed. Two (2) bolts secure the cabinet to the wooden skid. The bolts are located at each end on the underside of the cabinet. Using a 3/4" socket or open end wrench, remove the bolts. You can now lift the cabinet off the skid, or carefully knock the wood supports off each end of the skid and roll your milk cooler off.

IMPORTANT NOTE: Do not under any circumstances, lay your new model on its front or sides. For a brief period of time, you may lay the cabinet on its back, but only when it's properly blocked so as not to crush the back or end panels and also to allow provision for your hands, in order to set it in its upright position without damaging the cabinet. **Do not plug in and operate model for at least three (3) hours after cabinet is set upright from being on its back as this can damage the compressor.**

GENERAL INFORMATION AND IMPORTANT OPERATING FACTS

This manual has been compiled to aid in the installation, operation and maintenance of your new equipment. Please take the time to read it and familiarize yourself with your equipment and its operation, to enjoy optimum performance.

Continental Refrigerator offers a variety of accessories for your model (see **"Optional Accessories"** section towards the back of this manual or contact your dealer for more information).

SERIAL DATA TAG

A serialized data tag is permanently attached to the inside right-hand wall of your unit. (see **Figure 1**). In addition to identifying the specific product, this label provides important information regarding electrical requirements and refrigeration charge, as well as agency listings and factory contacts.

FIGURE 1: Data Tag

Continental Refrigerator					
539 Dunksferry Road • Bensalem, PA 19020-5908					
215-244-1400 • 800-523-7138 • FAX: 215-244-9579					
Division of National Refrigeration and Air Conditioning Products, Inc.					
MODEL			SERIAL		
POWER SUPPLY	WIRES		VOLTS	HZ.	PH.
	VOLTS	HERTZ	PHASE	AMPS.	
CABINET			COND. UNIT		
DEFROST			AMOUNT OZS.		
REFRIGERANT TYPE					
DESIGN PRESSURE LIMIT		PSI LOW SIDE	PSI HIGH SIDE		
COMMERCIAL REFRIGERATOR FREEZER					
CONFORMS TO U.L. STANDARD 471					
					
<small>IMPORTANT NOTICE: FOR WARRANTY PARTS AND SERVICE AUTHORIZATION CALL THE SERVICE DEPARTMENT AT 1-800-523-7138</small>					

IMPORTANT NOTE: The model and serial number should be noted on the front cover of this manual, in the spaces provided. If parts or service are ever needed for your unit, this information will be required to verify warranty status and to properly identify any parts that may be needed.

All cabinets must be given sufficient time to reach normal operating temperature before placing any pre-chilled milk inside cabinet. Approximately 1 hour of operation is required to lower the cabinet temperature to 38°F (4°C). During pull-down, doors and lids should be kept closed (see **"Operation"** section for further information).

IMPORTANT NOTE: It is strongly recommended that top lids and doors be kept in the closed position when the unit is not in use or between rush periods. This is extremely important during the summer months and in hot kitchens. **Do not** keep the top lids and doors open for prolonged periods of time and **never** operate forced air models for longer than four hours with lids and doors open as evaporator coil can ice and may have to be manually defrosted.

Prior to factory shipping, all products are performance-run tested for a minimum of 12 hours providing a highly sophisticated temperature recording exclusive to each individual cabinet. This recording is supplied within this manual packet. A final evaluation, including analysis of cabinet performance, leak check, vibration, noise level and visual examination is made by a qualified quality control team to assure a superior product. The carrier signs to this effect when they accept the product for shipping. To insure the maximum in safety and sanitation, all models are listed under the applicable standards of Underwriters Laboratories and the National Sanitation Foundation.

INSTALLATION AND LOCATION

Before moving the cabinet to its final point of installation, measure all doorways or passages to assure sufficient clearance.

VENTILATION

The final location site of your forced air or cold wall refrigerator **must** provide a large quantity of cool, clean air. All refrigeration systems operate most efficiently and trouble-free with cool, dry air circulation. Avoid locations near heat and moisture generating equipment including ovens, cooking ranges, fryers, dishwashers, steam kettles, etc., or in direct sunlight (where temperatures can exceed 100°F). Do not select a location in an unheated room or area where temperatures may drop below 55°F. Air supply to the condensing unit is equally important. Restricting the air places an excessive heat load on the condensing unit and adversely affects its operation.

IMPORTANT NOTE: To assure maximum operating efficiency, your new cabinet should be located where an unrestricted air supply can be circulated to the condensing unit. For optimum performance, a minimum clearance of 3" on each side and rear of the cabinet should be

provided. Your model has been designed to operate only with the casters supplied. **Do not** at any time obstruct the area below the grill in the front or rear of the cabinet in any way, and never place or store anything inside of the cabinet machine compartment. These rules are essential for maximum cooling capacity and long life of refrigeration parts.

FLOOR DRAINS AND LOADS

Your milk cooler should be located over top of, or close to, a building floor drain. The floor should provide level positioning, be free of vibration and strong enough to support the total combined weights of your new model plus the maximum product load which might be placed into it. Keep in mind that all the weight is concentrated at the casters. To estimate the possible product weight, assume that each cubic foot of storage space weighs approximately 35 pounds. Multiply 35 pounds by the amount of cubic feet in the cabinet to obtain the product load weight.

For example, a 20 cubic foot refrigerator can hold approximately 700 pounds of product (35 x 20). Assuming the cabinet itself weighs 300 pounds, the total combined weight of cabinet and product is approximately 1000 pounds. Therefore, the floor in this example must be able to support up to 1000 pounds.

CABINET CLEAN OUT DRAIN AND HOSE

All forced air and cold wall models contain a 1" diameter clean out drain with a drain stopper and 3' long ¾" ID drain hose. The floor drain is located on the bottom right hand floor in the storage compartment. The external drain connection and hose are accessible behind either the front or rear grill (**see Figure 3 for location**). A flexible hose, attached to the drain line under the cabinet, is located behind the front grill, toward the right hand side (**see Figure 3**). The clean out drain hose should be routed directly to a building floor drain. Never place the hose in the condensate pan of your milk cooler. The hose must be positioned safely so any liquid flows directly into the floor drain and does not spill onto the floor, to avoid any tripping or slipping hazards.

IMPORTANT NOTE: It is very important that your milk cooler is properly level during operation. If it is not level, doors won't close properly and gaskets won't provide a good seal, which will cause your unit to run excessively. Excess ice will accumulate inside the cabinet, around the door openings and on the forced air evaporator coil. If allowed to continue, ice will eventually block the coil and the refrigeration system won't be able to maintain proper temperature, resulting in loss of product stored inside. In addition, a cabinet that is not level will allow condensation water to overflow the pan and spill into the storage compartment.

EVAPORATOR CONDENSATE REMOVAL

(Forced Air Models)

All forced air models have a built-in electric condensate vaporizer located on the underside of the cabinet (**see Figure 3**) and are completely self-defrosting. To clean the vaporizer, disconnect the power by unplugging the cabinet power cord from the supply. Remove the front grill by taking out the 2 screws at each end. Gently pull the grill forward, away from the cabinet, being careful not to damage the tubing from the thermometer to the sensing bulb. The electric vaporizer is provided with a cord, that must be securely plugged into the proper receptacle on the control box.

IMPORTANT NOTE: It is extremely important to ensure the condensate pan is plugged into the receptacle labeled "vaporizer" and that the condensing unit is plugged into the receptacle labeled "condensing unit." **DO NOT** connect the floor drain to the condensate pan. The electric vaporizer is provided to eliminate condensation moisture only. Placing the floor drain hose in the electric vaporizer will create unsanitary and unpleasant odors. Water from the floor drain will also overflow the condensate pan and spill onto the floor, creating unsafe conditions.

FIGURE 2: Milk Cooler Components (Forced Air Models)

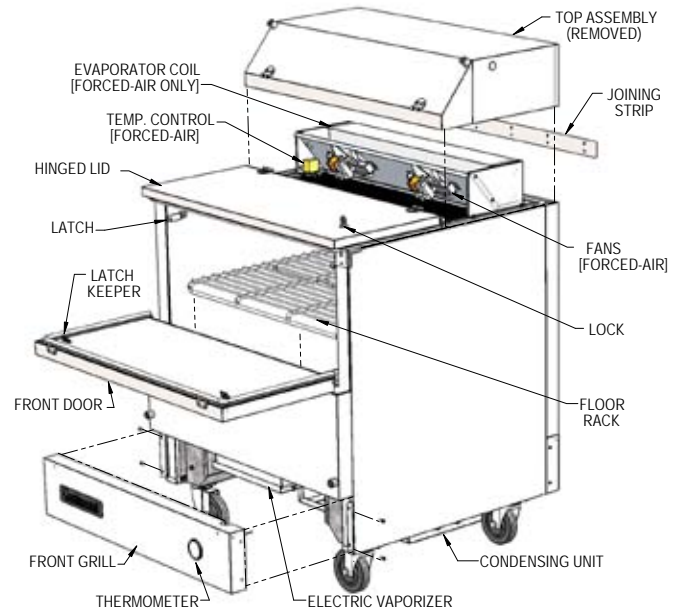
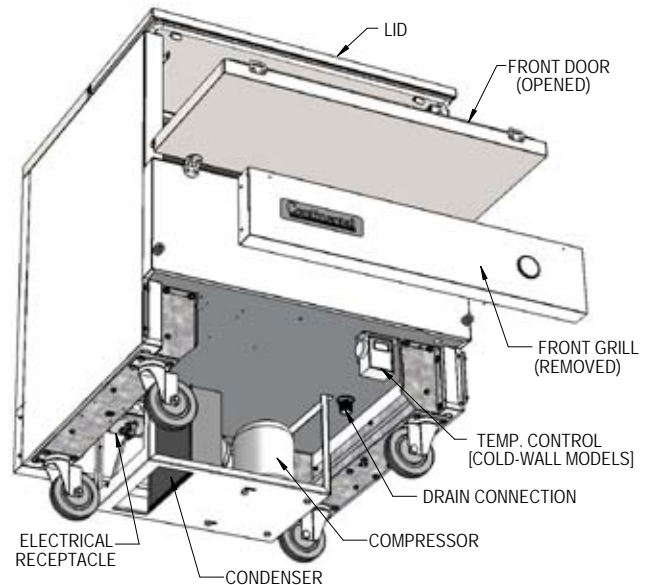

FIGURE 3: Milk Cooler Components (Cold-Wall Models)



INITIAL CLEANING PROCEDURE

Prior to start-up and before placing any product inside of your cabinet, the interior should be thoroughly cleaned. Washing with a mild soap and warm water solution is recommended for removing dirt and grime from the surfaces of your cabinet. This should be followed by cleaning with a baking soda solution (three (3) tablespoons of baking soda to each quart of warm water). Rinse thoroughly with clear water and dry with a clean, soft cloth.

IMPORTANT NOTE: Never use harsh detergents, cleaners, scouring powders or chemicals when cleaning your model. Failure to dry the interior surfaces after cleaning may result in a streaking or staining of the metal.

Complete cleaning procedures and precautions are listed in the (“**Periodic Cleaning Procedure**” under “**Maintenance**”).

START-UP PROCEDURE

ELECTRICAL CONNECTIONS

To insure proper operation, your new model must be connected to an individual circuit that can supply the full voltage as stated on the cabinet serial data plate. For correct voltage, power draw, and wire accommodations, check the data on the serial data plate located on the inner right wall of your new model. Verify that this information exactly matches the electrical characteristics at the installation location. An electrical wiring diagram, located on the inside compressor compartment rear, next to the electrical console box, should also be consulted during connection. For reference, a copy of each electrical wiring diagram is located towards the back of this manual (see “**Wiring Diagrams**” section).

Refrigeration compressors are designed to operate within +/-10% of the rated voltage indicated on the cabinet serial plate. Excessively high or low supply power can burnout the compressor. This can be easily detected and will void the factory warranty. Full voltage at the correct rating, on a separate, designated circuit, not affected by the operation of other electrical appliances, must be available to the refrigeration unit at all times. Extension cords should never be used on commercial equipment, as they can overheat and/or result in low voltage.

GFI/GFCI RECEPTACLES

Building codes in some areas may require certain 115 volt

receptacles to be protected by a Ground-Fault Circuit Interrupter (GFCI or GFI). These devices are not recommended for most commercial refrigerators and freezers, since nuisance trips can occur (typically due to moisture) causing temporary loss of power. This may result in intermittently high storage temperatures and potentially unsafe food product. If you decide to connect your equipment to a GFCI protected receptacle, a properly sized, commercial grade circuit breaker should be used on a separate, designated power supply. Alternatively, a qualified electrician may be able to hard wire your equipment, eliminating the need for a GFCI device. Contact Continental’s Service Department before making any modifications to your cabinet, to avoid loss of warranty coverage.

NOTE: GFCI DEVICES ARE NOT RECOMMENDED. PRODUCT LOSS AND/OR PROBLEMS RESULTING FROM NUISANCE TRIPS OR CONNECTION TO A DEFECTIVE OR IMPROPER POWER SUPPLY, ARE NOT COVERED UNDER WARRANTY. **UNAUTHORIZED MODIFICATIONS TO YOUR EQUIPMENT OR THE POWER CORD CAN CAUSE AN ELECTRICAL HAZARD AND WILL VOID THE FACTORY WARRANTY.**

115 VOLT, 60 HZ, 1 PHASE CONNECTION

All 115 volt models are provided with a factory installed, UL approved 15-amp power cord and NEMA 5-15P plug, or a 20-amp cord with a NEMA 5-20P plug. To insure proper operation, this equipment must be plugged into a NEMA compatible, grounded receptacle that can supply the full voltage and amperage stated on the serial plate (see **Figure 1**).



NEMA 5-15P

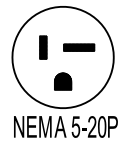

NEMA 5-20P

IMPORTANT NOTE: A SEPARATE, ISOLATED, PROPERLY SIZED POWER SUPPLY MUST BE PROVIDED. GFCI DEVICES AND/OR EXTENSION CORDS SHOULD NOT BE USED. PRODUCT LOSS, AS WELL AS PROBLEMS RESULTING FROM NUISANCE TRIPS OR HIGH/LOW VOLTAGE, ARE NOT COVERED UNDER WARRANTY.

SPECIAL VOLTAGE CONNECTIONS

When models are ordered from the factory with special, optional voltages, connections should be made as required on the electrical wiring diagram provided on the inside compressor compartment rear next to the electrical console box.

START-UP CHECKLIST

After your unit has been installed and power connected in accordance with this manual, please take time to check the following before loading product, to assure trouble-free operation:

- ❑ Cabinet location suitable and unit is level (see “**Installation and Location**”)
- ❑ Separate power supply with correct voltage (see “**Electrical Connections**”)
- ❑ Drain hose routed to floor drain (see “**Installation and Location**”)
- ❑ Vaporizer connected (see “**Evaporator Condensate Removal**”)
- ❑ Doors and lids close and seal properly (see “**Door Latch and Lid Lock**”)
- ❑ Cold Wall Models: Correct cabinet temperature (see “**Cold Wall Refrigeration System and Adjustment**”)
- ❑ Forced Air Models: Correct cabinet temperature (see “**Forced Air Refrigeration System and Adjustment**”)
- ❑ Refrigeration lines free of kinks and vibration (see “**Refrigeration System**”)
- ❑ All packaging discarded and cabinet cleaned (see “**Periodic Cleaning**”)

The system should run smoothly and quietly in accordance with generally accepted commercial standards. If any unusual noises are heard, turn the unit off immediately and check for obstructions of the condenser or evaporator fans. Fan motors, blades, and housings can be jarred out of position through rough handling in transit.

CAUTION: IF POWER IS DISCONNECTED FOR ANY REASON, ALLOW 5 MINUTES FOR THE SYSTEM TO EQUALIZE BEFORE TURNING THE UNIT BACK ON. DISREGARDING THIS PROCEDURE MAY CAUSE AN OVERLOAD AND PREVENT THE UNIT FROM OPERATING!

OPERATION

All cabinets must be given sufficient time to reach normal operating temperature before placing pre-chilled product inside. Milk coolers are designed to maintain a cabinet temperature of 38° to 40°F (3.3° to 4.4°C). Approximately 1 hour of operation is required to reach this temperature. During pull-down, doors and lids should be kept closed. Due to the open design and use of milk coolers, it is normal for condensation to periodically form around the door and lid seams and hinges.

DOOR LATCH AND LID LOCK

To open your milk cooler, unlock the lid by turning the key so the cam disengages from the keeper (see **Figure 4**). Lift the lid and slowly rotate it back, so it rests against the bumpers. Locate the door latch on the interior side wall. Lift up on the front of the latch and rotate it back, to disengage it from the keeper. The door will now freely rotate down. Lower it gently so it rests against the front bumpers. To close, lift the door back into place and rotate the latch to engage the keeper. Close the lid by rotating forward and lower it into place, so the clips engage into the accepters at each end of the door.

NOTE: The lid clips and accepters secure the door, so it cannot be opened until after the lid is unlocked and opened. Always close the door before closing the lid.

FIGURE 4: Door Latch and Lid Lock

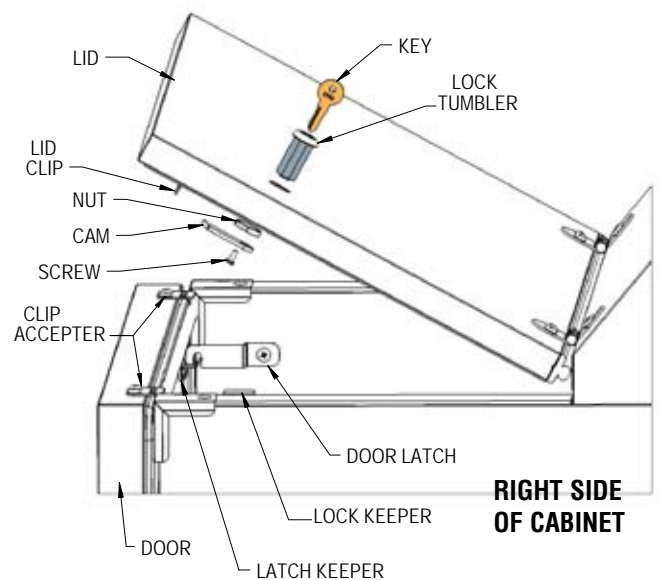

LATCH ADJUSTMENT AND LOCK REPLACEMENT

If the lid or door does not close properly, check alignment of the clips on underside of the lid and the accepters inside the door (see **Figure 4**). To adjust, loosen the screws, move clip or acceptor to position desired and retighten the screws. Use the same method to adjust the latch keeper if needed. To remove the lid lock, start on the inside. Use a large philips screwdriver to turn the lock screw counter-clockwise to loosen it. Remove the screw and cam. Use a large wrench to turn the nut counter-clockwise and remove it. From outside the lid, pull the tumbler out of the hole. To replace the lock, reverse the above steps.

DIAL THERMOMETER AND CALIBRATION

Your NSF-approved dial thermometer has a remote sensing bulb, located in the refrigerated compartment. The display features a large 2" diameter face, with any easy to read scale that shows the internal cabinet temperature in Fahrenheit (°F) and Celsius (°C). Blue (safe) and red (caution) color bands provide a quick, visual indication of the temperature inside your refrigerator. The thermometer is pre-calibrated at the factory, to accurately show the cabinet temperature.

To check the accuracy of your thermometer, place a pre-calibrated temperature sensing device in the center of the refrigerated compartment and keep the door closed for at least 10 minutes. The thermometer should read the same temperature as the sensing device, within +/-2°F (+/- 1°C). If it does not, use a small straight-blade screwdriver to carefully pry the clear lens cover from the thermometer body as shown (see **Photo A**).

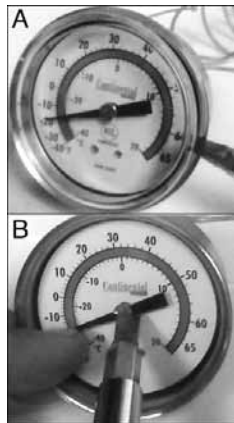

Place the screwdriver tip in the slotted center screw on the thermometer face. Carefully hold the needle pointer and turn the center screw clockwise to lower or counterclockwise to increase the desired temperature, as shown (see **Photo B**). Replace the lens cover and recheck the calibration.

COLD WALL REFRIGERATION SYSTEM AND ADJUSTMENT

All self-contained "cold wall" milk cooler refrigerators are designed and factory set to maintain an average cabinet temperature of 36°F. The temperature control is located behind the front grill (see **Figure 3**). Remove the front grill by taking out the 2 screws at each end. Gently pull the grill forward, away from the cabinet, being careful not to damage the tubing from the thermometer to the sensing bulb. . If an adjustment is necessary to maintain the above temperature range only, place a screwdriver into the bottom thermostat adjustment screw (see **Figure 5**) labeled "Cut-In" and turn clockwise for a colder cabinet temperature or counterclockwise for a warmer cabinet temperature. Note that adjusting a cabinet too cold (below the "Cut-In" setting of 30°F) could result in freezing your product over long periods of time. Further adjustments out of the factory design temperature range must be made by a qualified refrigeration mechanic only. The cold wall system operates by wall

temperatures reaching below freezing (approximate wall temperature is 20°F) and should periodically be manually defrosted to minimize wall ice accumulation. To manually defrost your milk cooler, unload all product and place it in a refrigerated storage unit. Keep the lids and doors open, and disconnect power to the cabinet (by unplugging the power cord) for approximately 30 minutes allowing the frost to melt and drain to the floor drain. Care should be taken not to scrape and potentially puncture the wall since the refrigeration tubing is located behind the wall and could be damaged.

IMPORTANT NOTE: During manual defrost, be sure to connect your floor drain to a drainage destination.

FIGURE 5: Cold Wall Thermostat

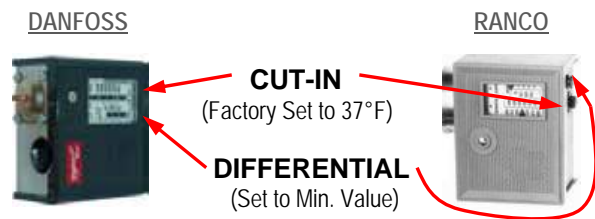

FORCED AIR REFRIGERATION SYSTEM AND ADJUSTMENT

All self-contained "forced air" milk cooler refrigerators are designed and factory set to maintain an average cabinet temperature of 36°F. Due to the open-type design and use of milk coolers, it is normal for condensation to periodically form around the door and lid seams and hinges, particularly if the temperature has been set too cold. If moisture becomes excessive check, the control settings. The temperature control is located inside the cabinet product compartment, on the interior top left air distribution grill as shown in **Figure 2**. If an adjustment is necessary to maintain the above temperature range only, place a screwdriver into the thermostat slot and turn clockwise for a colder cabinet temperature or counterclockwise for a warmer cabinet temperature. **PLEASE NOTE that turning the control completely counterclockwise will turn "off" the refrigeration compressor, as it is an "off" position.** Further adjustments out of the factory design temperature range must be made by a qualified refrigeration mechanic only.

REMOVAL OF TOP ASSEMBLY

(Forced Air Models Only)

The top assembly can be removed, by a qualified technician, to access the evaporator coil, fans and related components (see Figure 6). Removal and replacement will require a philips screwdriver, razor knife, tube of NSF-approved silicone sealant and a silicone gun. To begin, open the front door and lid. Remove the lid hinge screws from the top assembly. On single access models, remove the joiner strip and screws from the back of the cabinet (see Figure 3). For dual access models, remove the screws from the hinges on the back Lid (see Figure 4). Set the lid(s), hinges and other parts aside. Use a razor knife to carefully score the silicone seal around the base of the top assembly. **BE EXTREMELY CAREFUL** to avoid cutting yourself or scratching your milk cooler. From inside the storage compartment, remove screws from the underside of the top assembly. Gently lift the top assembly straight up and off the cabinet. To reattach the top, clean all excess sealant, reverse the above steps and use silicone to provide an airtight seal between the top and cabinet.

FIGURE 6: Forced Air Top Removal

(Dual Access Model Shown)

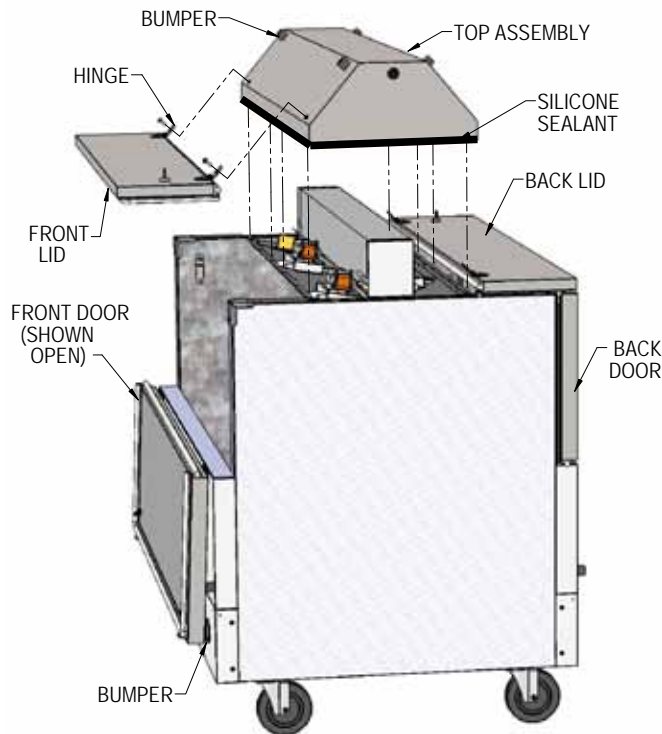

IMPORTANT NOTE: All refrigerators are designed with an automatic, “off-cycle” defrost system. Defrosting occurs automatically when the compressor is not operating during an off-cycle. Do not set the thermostat where the cabinet temperature will fall below 34°F because the evaporator will become blocked by ice since the compressor off-cycle will be considerably shortened. This will result in loss of product stored within the cabinet and require service to defrost the evaporator and re-adjust the thermostat, which is not covered under warranty.

CAUTION: ON ALL “FORCED AIR” AND “COLD WALL” MODELS, IT IS STRONGLY RECOMMENDED THAT TOP LIDS AND DOORS BE KEPT CLOSED WHEN THE UNIT IS NOT IN USE OR BETWEEN RUSH PERIODS. THIS IS EXTREMELY IMPORTANT DURING THE SUMMER MONTHS AND IN HOT KITCHENS. DO NOT KEEP THE TOP LIDS AND DOORS OPEN FOR PROLONGED PERIODS OF TIME AND NEVER OPERATE FORCED AIR MODELS FOR LONGER THAN FOUR HOURS WITH LIDS AND DOORS OPEN AS EVAPORATOR COIL CAN ICE AND MAY HAVE TO BE MANUALLY DEFROSTED.

INTERIOR ACCESSORIES

The standard interior accessory package that is supplied from the factory with your milk cooler model consists of an epoxy-coated, steel wire floor rack (see Figure 2) which sits on the interior stainless steel floor (MC5 models receive two) with the legs facing down, as shown. A rubber stopper is also provided for the floor drain.

MAINTENANCE

SAFETY PRECAUTIONS

WHEN OPERATING ANY APPLIANCES: DISCONNECT THE POWER CORD BEFORE ATTEMPTING TO WORK ON OR CLEAN EQUIPMENT. DO NOT ATTEMPT TO REMOVE ANY COVERS OR PARTS YOURSELF, AS THIS CAN EXPOSE DANGEROUS, HIGH VOLTAGE WIRING. SERVICE SHOULD ONLY BE PERFORMED BY A QUALIFIED TECHNICIAN. ALWAYS ROUTE POWER CORDS AWAY FROM AREAS WHERE THEY CAN BE WALKED ON OR DAMAGED BY OTHER EQUIPMENT. NEVER USE EXTENSION CORDS OR PLUG MORE THAN ONE APPLIANCE INTO THE SAME CIRCUIT. THIS CAN OVERLOAD THE POWER AND RESULT IN ELECTRICAL SHOCK OR FIRE. YOUR APPLIANCE IS EQUIPPED WITH A POLARIZED, GROUNDED POWER PLUG. NEVER ATTEMPT TO REMOVE THE GROUND POST OR USE A NON-POLARIZED ADAPTER, WITHOUT PROPERLY GROUNDING THE EQUIPMENT. IF A REPLACEMENT PART IS REQUIRED, ALWAYS INSIST ON FACTORY AUTHORIZED COMPONENTS.

PERIODIC CLEANING PROCEDURE

It is always best to clean your refrigerator or freezer when the product load in your cabinet is at its lowest level. To clean the interior or exterior cabinet surfaces, follow these procedures:

1. Disconnect your cabinet from its power supply, remove all refrigerated product and temporarily move it to a walk-in or other refrigerated storage unit.
2. Roll your milk cooler to a location over a floor drain, open all doors and lids to allow the cabinet to reach room temperature. Remove the floor racks and the drain plug stopper from inside and wash them with a baking soda and warm water solution, rinse thoroughly with clean water. Dry all accessories completely with a soft clean cloth.
3. Once the cabinet has reached room temperature, wash all inside and outside surfaces with a solution of warm water and mild detergent. Pay particular attention to the face of the cabinet, as any residue or debris can impair the door seal. For slightly more difficult cleanups, ammonia or vinegar and warm water can be used. Rinse thoroughly with clean water and dry with a soft clean cloth. Carefully wash all door gaskets with clean water, dry them and check for any damage, which may affect the seal. Failure to dry surfaces completely may cause water stains or streaking.

4. Replace the drain stopper, place the floor racks properly in position and, reconnect the power. Wait at least 1 hour before reloading product into your unit.

PRECAUTIONS

NEVER USE HARSH DETERGENTS, CLEANERS, SCOURING POWDERS, OR CHEMICALS WITH BLEACH WHEN CLEANING YOUR UNIT.

GENERAL PREVENTATIVE MAINTENANCE

The most important thing you can do to maintain any refrigerator or freezer and extend its life, is to keep the condenser clean. Performance of the air-cooled condensing unit, located under the cabinet, depends exclusively upon the amount of air passing through the condenser fins. Your refrigerator or freezer will run more efficiently, consume less energy, and provide a maximum of trouble-free service throughout its lifetime if the condenser is kept clean and an adequate supply of clean, cool air is provided at all times. Periodically (at least once a month) inspect the condenser coil, which is located directly behind the rear grill, to check for debris or blockage (**see Figure 3**).

If the condenser coil is dirty or blocked, disconnect the cabinet power supply and using a stiff brush, wipe away any dirt from the condenser fins until the condenser is clear from any debris. Using a vacuum cleaner with a brush attachment may aid in this cleaning process. After cleaning, restore electrical service to your model.

CAUTION: CONDENSER FIN PLATES ARE MADE FROM THIN METAL AND HAVE SHARP EDGES. ALWAYS WEAR GLOVES. USE CAUTION WHEN WORKING ON OR AROUND THE CONDENSING UNIT TO PREVENT CUTS AND AVOID DAMAGING FINS, TUBING AND OTHER COMPONENTS. FAILURE TO PROPERLY CLEAN THE CONDENSER REGULARLY WILL CAUSE EXCESSIVE COMPRESSOR LOAD, REDUCING THE PERFORMANCE AND EFFICIENCY OF YOUR UNIT. THIS CAN RESULT IN PREMATURE FAILURE AND VOID YOUR WARRANTY.

CARE AND CLEANING OF STAINLESS STEEL*

*Some information and graphics for this section were obtained from "Stainless Steel Equipment Care and Cleaning" brochure, published by the North American Association of Food Equipment Manufacturers (NAFEM).

Contrary to popular beliefs, stainless steel can rust, if not properly cared for and maintained (That's why it's called stain-LESS steel, not stain-PROOF steel.)

All steel is primarily made of iron. Stainless steels contain other metals, such as chromium and nickel, that provide an invisible film on the surface of the steel that acts as a shield against corrosion. As long as this invisible layer is intact and not broken or contaminated, the metal will retain its corrosion protection and remain stain-less.

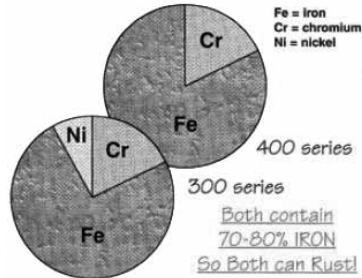

There are 3 basic things that can break down the protective layer on your stainless steel, which must be avoided:

1. **MECHANICAL ABRASION** is caused by things that scratch the surface of the metal. Only use soft cloths or plastic scouring pads to clean and always scrub in the same directions as the metal grain.

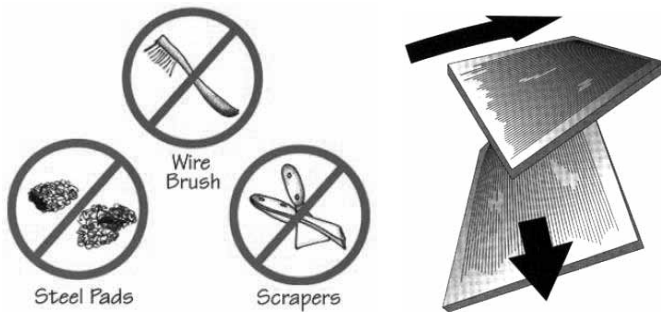

DO NOT USE: steel pads, wire brushes, scrapers or knives to clean your equipment.

2. **CHLORIDES** are found in water, salt, food and worst of all, many cleaners. Only use chloride-free, alkaline-based, non-abrasive cleaners. Always rinse thoroughly with cool, clean water and dry with a soft towel. A solution of 1 tablespoon baking soda mixed with 1 pint water can be used to remove tough stains.



DO NOT USE: abrasive cleaners, chemicals with chlorides or muriatic acid to clean your equipment.

3. **HARD WATER** causes spots and stains on stainless steel surfaces, particularly when it is heated. Find out the hardness of your water and treat it properly, if needed. Use a water filter and softeners if you have hard water. Club soda can be used to remove streaks or spots.

U.S. WATER HARDNESS MAP

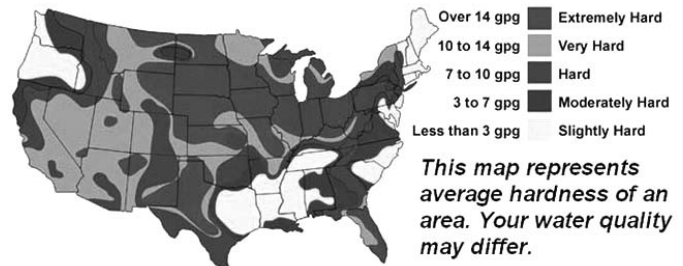

DO NOT USE: hot or hard water to clean stainless steel.

CLEAN YOUR STAINLESS STEEL REGULARLY using the proper tools and cleaners. After cleaning, always **rinse, rinse, rinse** thoroughly with **cool, clean, clear water**.

CHECK ALL OF YOUR EQUIPMENT PERIODICALLY. If you see any signs of rust, clean the area immediately, with a plastic scrubbing pad. If surface rust is removed promptly, permanent corrosion, pits and cracks may be avoided. Special stainless steel polishes, that can help restore the protective coating on your equipment, are available from a variety of retailers.

IMPORTANT: If these recommendations are not followed, the protective film on your stainless steel can break down and your equipment may begin the long walk down the dark road of corrosion.

PARTS AND SERVICE

Continental is committed to providing the best customer service in the industry. All new units come with a Limited Extended Protection Warranty (see “**Warranty**” section of this manual for details). If a problem arises with your equipment, please contact our Service Department at **1-800-523-7138** (extension 3301, 3302, or 3303). One of our Service Specialists will do everything possible to solve the problem as quickly as possible.

ITEMS NOT COVERED UNDER WARRANTY INCLUDE, BUT ARE NOT LIMITED TO:

- **Preventative maintenance:** cleaning condenser coils and other components.
- **Consumables:** light bulbs, door gaskets, batteries.
General hardware adjustments: cabinet leveling, casters/legs, doors/hinges.
- **Problems due to:** inadequate installation or supply power; improper maintenance, operation, or abuse.
- **Compressor failure due to:** dirty condenser, insufficient clearance/ventilation, excessive temperatures.
- **System adjustments and calibrations, including:** controls, thermometer and expansion valves.

Consult the Table of Contents in the front of this manual for detailed information on the items listed above. Contact Continental’s Service Department with any additional questions.

PLACING A SERVICE CALL

In order to receive prompt service, always be prepared to provide your: cabinet model and serial number; cabinet location name and date installed; contact name and phone number; plus a description of the problem.

During normal business hours (Monday to Friday, 8am to 5pm Eastern) contact the Service Department at: **1-800-523-7138** (extension 3301, 3302, or 3303) **prior to any warranty service work being performed.**

After normal business hours, or on weekends, notify our Service Department by sending an email to: jcadwallader@nrac.com, or leaving a voice message at: **1-800-523-7138** (extension 3301). Be sure to provide the information listed above. Contact Continental the following business day, during normal business hours, to verify the status of your call.

OBTAINING REPLACEMENT PARTS UNDER WARRANTY

If replacement parts are required for a unit under warranty, contact Continental’s Service Department. New parts will be sent from the factory and, when applicable, a Return Goods Authorization (RGA) will be issued to return old parts. The RGA number must appear on the packaging of any parts returned, or they will not be accepted. If a service agent uses a part from their stock, Continental will replace it with a factory part.

OBTAINING REPLACEMENT COMPRESSOR UNDER WARRANTY

If the compressor should fail within the first twelve (12) months of use, or within twenty (20) months from the date code on the compressor, an “over-the-counter” exchange must be made at an authorized Copeland, Danfoss, Embraco, or Tecumseh wholesaler.

After the first year, the compressor motor is covered under an extended “parts only” warranty. The customer is responsible for any labor charges and any additional parts that may be required. Contact the Service Department to obtain a replacement compressor through one of the following methods:

- Continental will supply a replacement compressor at no charge and pay for regular freight. (If expedited freight is requested, the end user, dealer or service agent is responsible for additional charges and must provide credit card information.
- A compressor can be purchased locally and Continental will either replace the stock unit with a new factory compressor, or offer an allowance towards the purchase of a replacement compressor, up to: \$100 for 1/5hp to 1/3hp; \$250 for 1/2hp to 3/4hp; \$350 for 1hp to 2hp.

The data tag from the defective compressor (or compressor model, serial number and date code, if the tag cannot be removed) must be included with any reimbursement request.

OPTIONAL ACCESSORIES

Continental offers a variety of accessories for your unit.

DIGITAL THERMOMETER AND CALIBRATION

The optional digital thermometer has a remote sensing bulb, located inside the cabinet on the left-hand wall. The easy to read LED display is calibrated at the factory to accurately show temperature at the center of the refrigerated compartment. While in transit, your cabinet will be subjected to more jarring and vibration than at any other time, and the thermometer may require adjustment at start-up.

Milk coolers are designed to maintain 38° to 40°F (3.3° to 4.4°C). During periods of heavy use, when doors are opened repeatedly or remain open for an extended period, or if warm product is loaded into the cabinet, the temperature displayed may temporarily exceed the “normal” range. This is common, as warm air outside the cabinet mixes with cold air inside. If your thermometer continues to display temperature above “normal” range, close the doors, make sure they seal tight and keep them closed for at least 30 minutes. If a high temperature is still displayed, check the thermometer by placing a pre-calibrated temperature sensing device in the center of the refrigerated compartment and keep the doors closed for at least 15 minutes. The thermometer display should read the same temperature as the sensing device, within +/-2°F (+/-1°C). If it does not, follow the instructions below to calibrate the thermometer display, by adjusting the offset value as required.

To calibrate, press on the right center of the front display twice (see photo). After the first press, “CAL” will appear (unit is in Calibration mode). After the second press, the temperature offset value (-30 to 30) will appear.

Once you see this, press on the front lower left to decrease temperature displayed, or on the upper left section to increase temperature displayed. After adjusting the offset, press the right center of the front display again to exit calibration mode. Wait 10 to 15 seconds for the cabinet temperature to appear and recheck the display calibration.

For example, if sensing device in the cabinet reads 38° and thermometer displays 41°, press on the front right of the display twice to show the current offset value. Then press the lower left of the display three times to decrease offset by 3°. (If the original offset value displayed was “0”, then “-3” will appear.)

NOTE: The buttons need to be pressed without delay between actions. Contact the factory with any questions.

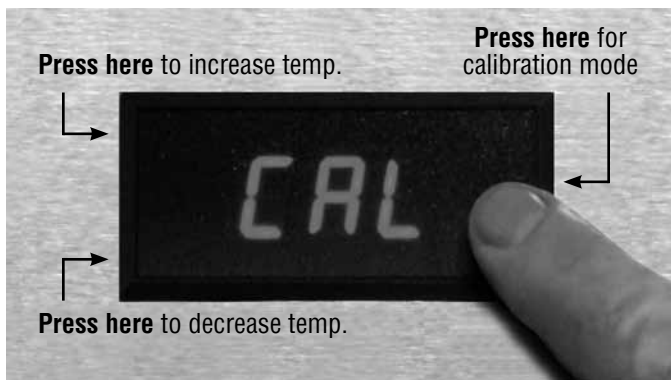

MILK COOLERS FORCED AIR & COLD WALL

TROUBLESHOOTING GUIDE

PROBLEM	PROBABLE CAUSE	CORRECTION
Condensing unit will not start - no hum.	<ol style="list-style-type: none"> 1. Line disconnected, switch open. 2. Fuse removed or blown. 3. Overload protector blown. 4. Control "Off" due to cold location. 5. Control stuck in open position. 6. Wiring improper or loose. 	<ol style="list-style-type: none"> 1. Close start or disconnect switch. 2. Replace Fuse. 3. Determine reason and correct/replace. 4. Relocate control. 5. Repair or replace control. 6. Check wiring against diagram.
Condensing unit will not start - hums but trips on overload protector.	<ol style="list-style-type: none"> 1. Improperly wired. 2. Low voltage to unit. 3. Starting capacitor defective. 4. Relay failing to close. 5. Compressor motor has a shorted or open winding. 6. Internal mechanical trouble in compressor. 7. Insufficient air supply. 	<ol style="list-style-type: none"> 1. Check wiring against diagram. 2. Determine reason and correct. 3. Determine reason and replace. 4. Determine reason and replace. 5. Replace compressor. 6. Replace compressor. 7. Clear condenser and allow compressor to cool down.
Condensing unit starts and runs, but short cycles on overload protector.	<ol style="list-style-type: none"> 1. Additional current passing through overload protector. 2. Low voltage unit. 3. Overload protector defective. 4. Run capacitor defective. 5. Excessive discharge pressure. 6. Excessive suction pressure. 7. Insufficient air supply. 	<ol style="list-style-type: none"> 1. Check wire diagram. Check for added components connected to wrong side of overload protector. 2. Determine reason and correct. 3. Check current, replace protector. 4. Determine reason and replace. 5. Check ventilation, restrictions in cooling medium or refig. system. 6. Check for misapplication. 7. Clear condenser and allow compressor to cool down.
Condensing unit starts, but fails to switch off of "start" winding.	<ol style="list-style-type: none"> 1. Improperly wired. 2. Low voltage to unit. 3. Relay failing to open. 4. Run capacitor defective. 5. Excessively high discharge pressure. 6. Compressor motor has a shorted or open winding. 7. Internal mechanical trouble in compressor. 	<ol style="list-style-type: none"> 1. Check wiring against diagram. 2. Determine reason and correct. 3. Determine reason and replace. 4. Determine reason and replace. 5. Check discharge shut-off valve, possible overcharge. 6. Replace compressor. 7. Replace compressor.
Condensing unit runs, but short cycles on:	<ol style="list-style-type: none"> 1. Overload protector. 2. Thermostat. 3. High pressure cut-out due to: <ol style="list-style-type: none"> (a) Insufficient air supply. (b) Overcharge. (c) Air in system. 4. Low pressure cut-out due to: <ol style="list-style-type: none"> (a) Valve leak. (b) Undercharge. (c) Restriction in expansion device. 	<ol style="list-style-type: none"> 1. Check current, replace protector. 2. Differential setting must be widened. 3. <ol style="list-style-type: none"> (a) Check air supply to condenser. (b) Evacuate and re-charge. (c) Evacuate and re-charge. 4. <ol style="list-style-type: none"> (a) Replace, evacuate and re-charge. (b) Evacuate and re-charge. (c) Replace expansion device.
Condensing unit runs, but for prolonged periods or continuous.	<ol style="list-style-type: none"> 1. Shortage of refrigerant. 2. Control contacts stuck closed. 3. Excessive heat load placed into cabinet. 4. Prolonged or too frequent door openings. 5. Evaporator coil iced. 6. Restriction in refrigeration system. 7. Dirty condenser. 8. Filter drier clogged. 	<ol style="list-style-type: none"> 1. Fix leak, evacuate and re-charge. 2. Clean contacts or replace control. 3. Allow unit sufficient time for removal of latent heat. 4. Plan or organize schedule to correct condition. 5. Defrost evaporator coil. 6. Determine location and remove. 7. Clean condenser coil. 8. Replace, evacuate and re-charge.

PROBLEM	PROBABLE CAUSE	CORRECTION
Start capacitor open, shorted or blown.	<ol style="list-style-type: none"> Relay contact not opening properly. Prolonged operation on start cycle: <ol style="list-style-type: none"> Low voltage to unit. Improper relay. Starting load too high. Excessive short cycling. Improper capacitor. 	<ol style="list-style-type: none"> Clean contacts or replace relay. <ol style="list-style-type: none"> Determine reason and correct. Replace with correct relay. Correct by using pump down. See "Condensing Unit Short Cycles" above. Determine correct size and replace.
Run capacitor open, shorted or blown.	<ol style="list-style-type: none"> Improper capacitor. Excessively high line voltage, over 110% of rated maximum. 	<ol style="list-style-type: none"> Check size and replace. Determine reason and correct.
Relay defective or blown out.	<ol style="list-style-type: none"> Incorrect Relay. Incorrect mounting angle. Voltage too low or too high. Excessive short cycling. Loose or vibrating mounting position. Incorrect run capacitor. Loose wiring on relay or overload. 	<ol style="list-style-type: none"> Check relay and replace. Remount relay in correct position. Determine reason and correct. See "Condensing Unit Short Cycles" above. Remount rigidly. Replace with proper capacitor. Tighten all wiring screws.
Product zone temperature too high.	<ol style="list-style-type: none"> Control setting too high. Inadequate air circulation. Dirty condenser. 	<ol style="list-style-type: none"> Adjust T-stat. Rearrange product load to improve air circulation. Clean condenser coil.
Suction line frosted or sweating.	<ol style="list-style-type: none"> Overcharge of refrigerant. Evaporator fan not running. Expansion valve stuck open. Expansion valve superheat too low. 	<ol style="list-style-type: none"> Evacuate and re-charge. Determine reason and correct. Clean valve, evacuate and re-charge. Adjust superheat to required setting.
Liquid line frosted, cold or sweating.	<ol style="list-style-type: none"> Restriction in drier strainer. Liquid line service valve partially closed. 	<ol style="list-style-type: none"> Replace drier, evacuate and re-charge. Open valve fully or replace if necessary.
Noisy condensing unit.	<ol style="list-style-type: none"> Loose parts or mounting. Tubing rattle or vibration. Bent fan blade causing excessive vibration. Fan bearings worn. 	<ol style="list-style-type: none"> Tighten all mounting parts and shroud cover. Reform tubing to be free of contact. Replace fan blade. Replace fan motor.
Thermometer reads different than actual temperature.	<ol style="list-style-type: none"> Calibration. Defective. 	<ol style="list-style-type: none"> Consult Operations Manual and calibrate. Replace.
Water leak inside unit.	<ol style="list-style-type: none"> Condensate drain pan not installed properly. Unit not level. Drain pan misaligned. Defective drain pan. 	<ol style="list-style-type: none"> Consult Operations Manual for install instructions. Make sure unit is level or pitched back slightly. Make sure drain pan is aligned properly. Replace.
Doors misaligned.	<ol style="list-style-type: none"> Shifted during shipping. 	<ol style="list-style-type: none"> Refer to Operation Manual for hinge adjustment.

**MILK COOLERS (FORCED AIR & COLD WALL MODELS)
WD-R5 WIRING DIAGRAM 115/60/1**

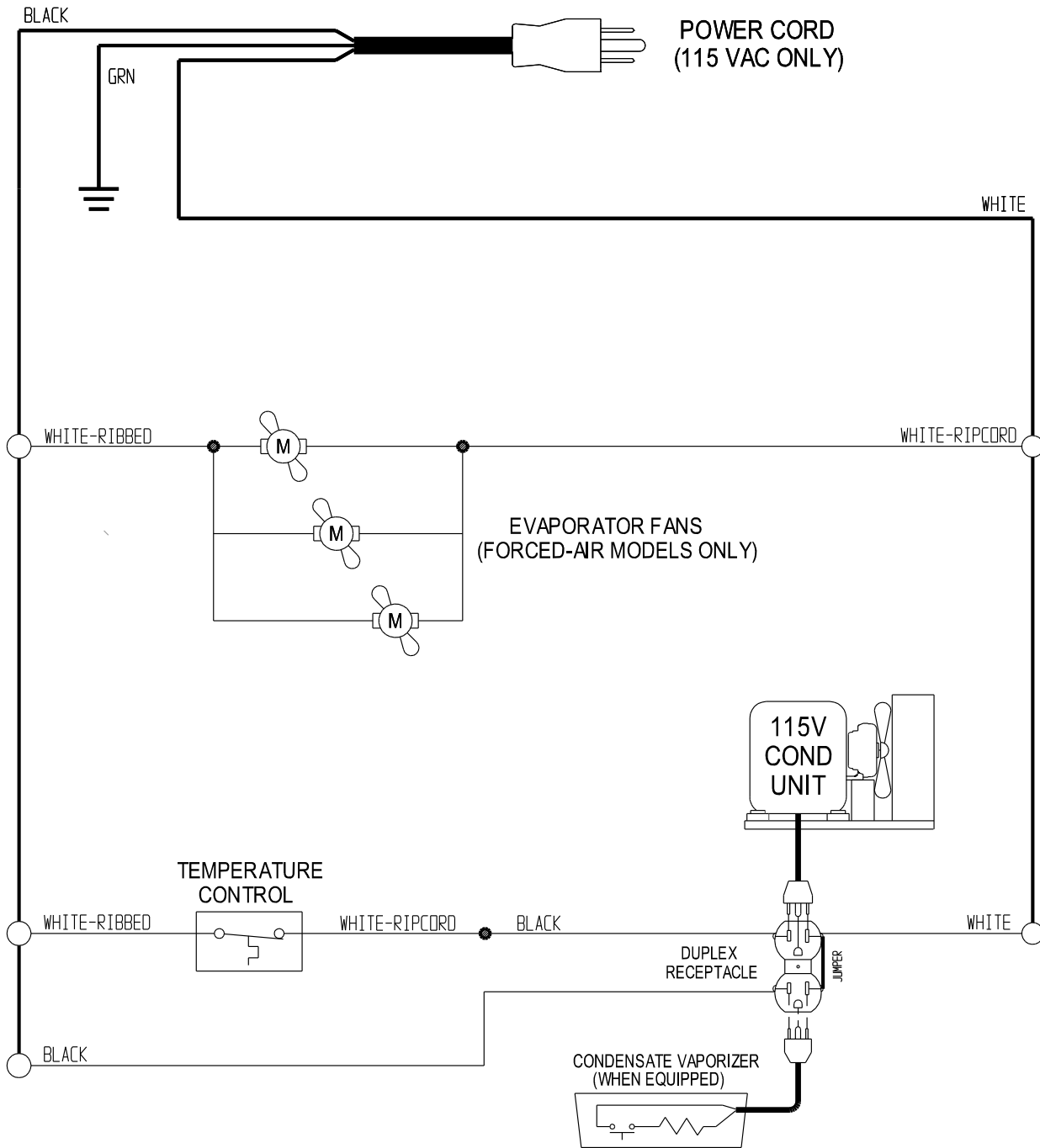

Continental

Refrigerator

THREE (3) YEAR PARTS AND LABOR WARRANTY

Continental Refrigerator warrants to the original purchaser of every new Continental Refrigerator self contained unit, including all parts thereof, that such equipment is free from defects in material and workmanship, under normal use, proper maintenance and service as indicated by Continental Refrigerator installation and operation manual, for a period of three (3) years from the date of installation, or thirty-nine (39) months from the date of shipment from the manufacturer, whichever comes first. Normal wear type parts, such as light bulbs/lamps and gaskets are not covered by this warranty. For the purpose of this warranty, the original purchaser shall be deemed to mean the individual or company for whom the product was originally installed.

Continental Refrigerators obligation under this warranty shall be limited to repairing or replacing, including labor, any part of such product which proves thus defective. Continental Refrigerator reserves the right to examine any product claimed to be defective. The labor warranty shall be for self-contained units only and for standard straight time, which is defined as normal service rate time, for service performed during normal working hours. Any service requested outside of a servicer's normal working hours will be covered under this warranty for the normal rate and any additional overtime rate will be the responsibility of the equipment purchaser.

Any part determined to be defective in the product should be returned to the company within thirty (30) days under the terms of this warranty and must be accompanied by the cabinet model, serial number, and identified with a return material authorization number, issued by the manufacturer.

Special installation/applications, including remote locations, are limited in coverage by this warranty. Any installation that requires extra work, and/or travel, to gain access to the unit for service is the sole responsibility of the equipment purchaser.

Improper operation resulting from factors, including but not limited to, improper or negligent cleaning and maintenance, low voltage conditions, inadequate wiring, and accidental damage are not manufacturing defects and are strictly the responsibility of the purchaser.

Condenser coils must be cleaned at regular intervals. Failure to do so can cause compressor malfunction and will void warranty. Continental Refrigerator recommends a minimum monthly cleaning, as stated in the installation and operation manual.

ADDITIONAL TWO (2) YEAR COMPRESSOR PART WARRANTY

In addition to the warranty set forth above, Continental Refrigerator warrants the hermetically/semi-hermetically sealed compressor (part only) for an additional two (2) years beyond the first three (3) year warranty period; not to exceed sixty-three (63) months from the date of shipment from Continental Refrigerator, provided upon receipt of the compressor, manufacturer examination shows the sealed compressor to be defective. This extended warranty does not cover freight for the replacement compressor or freight for return of the failed compressor. Also, this extended compressor-part only warranty does not apply to any electrical controls, condenser, evaporator, fan motors, overload switch, starting relay, capacitors, temperature control, filter/drier, accumulator, refrigeration tubing, wiring harness, labor charges, or supplies which are covered by the standard warranty above.

THE FOREGOING WARRANTIES ARE EXPRESSLY GIVEN IN LIEU OF ALL OTHER WARRANTIES, EXPRESS, IMPLIED, OR STATUTORY, INCLUDING THE IMPLIED WARRANTIES OF MERCHANTABILITY AND FITNESS FOR A PARTICULAR PURPOSE, WHICH ARE HEREBY DISCLAIMED, ALONG WITH ALL OTHER OBLIGATIONS OR LIABILITIES ON OUR PART. AND WE NEITHER ASSUME, NOR AUTHORIZE ANY OTHER PERSON TO ASSUME FOR US, ANY OBLIGATION OR LIABILITY IN CONNECTION WITH THE SALE OF SAID REFRIGERATION UNITS OR ANY PARTS THEREOF.

This warranty shall not be assignable and shall be honored only in so far as the original purchaser.

This warranty does not apply outside the limits of the United States of America and Canada, nor does it apply to any part that has been subject to misuse, neglect, alteration, accident, or to any damage caused by transportation, flood, fire, acts of terrorism, or acts of God.

IN NO EVENT SHALL CONTINENTAL REFRIGERATOR BE LIABLE FOR CONSEQUENTIAL, SPECIAL OR PUNITIVE DAMAGES. THE REMEDIES OF PURCHASER SET FORTH HEREIN ARE EXCLUSIVE AND THE TOTAL LIABILITY OF CONTINENTAL REFRIGERATOR, WHETHER BASED ON CONTRACT, WARRANTY, NEGLIGENCE, INDEMNIFICATION, STRICT LIABILITY, TORT, OR OTHERWISE, SHALL NOT EXCEED THE PURCHASE PRICE OF THE COMPONENT UPON WHICH LIABILITY IS BASED. CONTINENTAL REFRIGERATOR SHALL HAVE NO OBLIGATION OR LIABILITY FOR CONSEQUENTIAL OR SPECIAL DAMAGES, INCLUDING BUT NOT LIMITED TO INDIRECT, PUNITIVE DAMAGES, LOSS OF USE, LOSS OF PRODUCT, DOWNTIME OR LOST PROFITS, ARISING OUT OF, RELATED TO OR CONNECTED IN ANY WAY WITH THE PRODUCT OR ITS USE.

A Division of National Refrigeration & Air Conditioning Products, Inc.
539 Dunksferry Road • Bensalem, PA 19020-5908
P 215-244-1400 • 1-800-523-7138 • F 215-244-9579
www.continentalrefrigerator.com

Continental

Refrigerator

A Division of National Refrigeration & Air Conditioning Products, Inc.
539 Dunksferry Road • Bensalem, PA 19020-5908
P 215-244-1400 • 1-800-523-7138 • F 215-244-9579
www.continentalrefrigerator.com

