

# **MIB** MASTER-BILT® *Refrigeration Solutions*

*Deluxe Ice Cream Dipping/Display Merchandisers*

*DD – Standard Model*

*DD-L – Low Glass Model*

*DD-CG – Curved Glass Model*

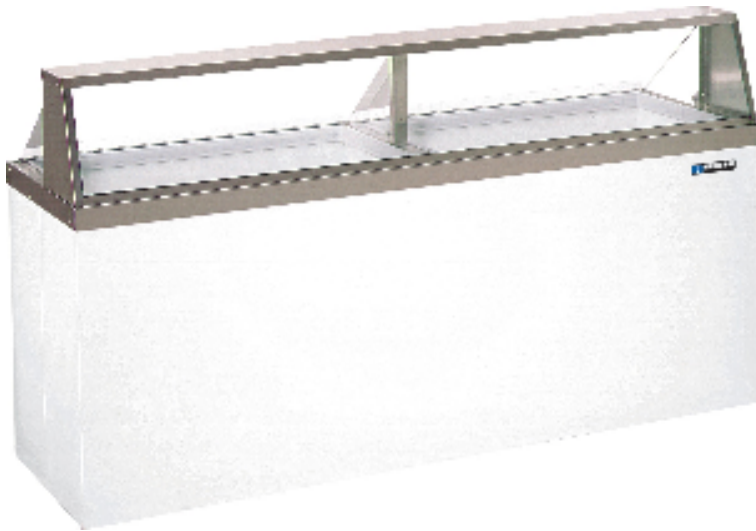

# **DD-26,46,66,88**

## **Installation & Operations Manual**

**Master-Bilt Products**  
908 Highway 15 North  
New Albany, MS 38652  
Phone: (800) 684-8988



# TABLE OF CONTENTS

<b>INTRODUCTION.....</b>	<b>4</b>
<b>STORE CONDITIONS.....</b>	<b>4</b>
<b>WARNING LABELS AND SAFETY INSTRUCTIONS.....</b>	<b>5</b>
<b>PRE-INSTALLATION INSTRUCTIONS.....</b>	<b>6</b>
Inspection for Shipping Damage.....	5
<b>INSTALLATION INSTRUCTIONS.....</b>	<b>6</b>
General Instructions.....	6
Electrical.....	6
Mechanical.....	7
Startup.....	7
<b>TEMPERATURE CONTROL.....</b>	<b>7</b>
<b>CLEANING INSTRUCTIONS.....</b>	<b>8</b>
Can Holder Cleaning.....	8
Frost Shield Cleaning.....	8
<b>OPERATION CONDITIONS AND PRESSURES .....</b>	<b>9</b>
Trouble Shooting.....	9
<b>SERVICE INSTRUCTIONS.....</b>	<b>9</b>
<b>MASTER-BILT® PART NUMBERS.....</b>	<b>10</b>
<b>ACCESSORIES.....</b>	<b>11</b>
<b>SALE AND DISPOSAL.....</b>	<b>11</b>
<b>WIRING DIAGRAMS.....</b>	<b>12-14</b>

## INTRODUCTION

Thank you for purchasing a Master-Bilt<sup>®</sup> cabinet. This manual contains important instructions for installing, using and servicing a Master-Bilt<sup>®</sup> DD case. A parts list is included in with this manual. Read all these documents carefully before installing or servicing your equipment.

## STORE CONDITIONS

The Master-Bilt<sup>®</sup> DD cases are designed to operate in the controlled environment of an air-conditioned store. The store temperature should be at or below 75°F and a relative humidity of 55% or less. At higher temperature or humidity conditions, the performance of these cases may be affected and the capacity diminished. It is not uncommon in a newly constructed store for the temperature and humidity to be above design conditions. These excessive conditions may produce sweating in the case until the store is operational and the ambient environment is more desirable.

The Master-Bilt<sup>®</sup> DD should not be positioned where it is directly exposed to rays of sun or near a direct source of radiant heat or airflow. This will adversely affect the case and will result in poor performance.



### NOTICE

**Read this manual before installing your cabinet. Keep the manual and refer to it before doing any service on the equipment. Failure to do so could result in personal injury or damage to the cabinet.**



### DANGER

**Improper or faulty hook-up of electrical components of the refrigeration units can result in severe injury or death.**

**NEVER use an extension cord to power this unit. All electrical wiring hook-ups must be done in accordance with all applicable local, regional or national standards.**



### NOTICE

**Installation and service of the refrigeration and electrical components of the cabinet must be performed by a refrigeration mechanic and/or a licensed electrician**

The portions of this manual covering refrigeration and electrical components contain technical instructions intended only for persons qualified to perform refrigeration and electrical work.

This manual cannot cover every installation, use or service situation. If you need additional information have the serial number at hand and call or write us:

Customer Service Department  
Master-Bilt Products  
Highway 15 North  
New Albany, MS 38652  
Phone (800) 684-8988  
Fax (800) 684-8988





## WARNING LABELS AND SAFETY INSTRUCTIONS



This symbol is the safety-alert symbol. When you see this symbol on your cabinet or in this manual, be alert to the potential for personal injury or damage to your equipment.

Be sure you understand all safety messages and always follow recommended precautions and safe operating practices.



### NOTICE TO EMPLOYERS

**You must make sure that everyone who installs, uses or services your cabinet is thoroughly familiar with all safety information and procedures.**

Important safety information is presented in this section and throughout this section and throughout the manual. The following signal words are used in the warnings and safety messages:

**DANGER:** Severe injury or death will occur if you ignore the message.

**WARNING:** Severe injury or death can occur if you ignore the message.

**CAUTION:** Minor injury or damage to your cabinet can occur if you ignore the message.

**NOTICE:** This is important installation, operation or service information. If you ignore the message, you may damage your cabinet.

The warning and safety labels shown throughout this manual are placed on your Master-Bilt Products cabinet at the factory. Follow all warning label instructions. If any warning or safety labels become lost or damaged, call your customer service department at (800) 684-8988 for replacements.

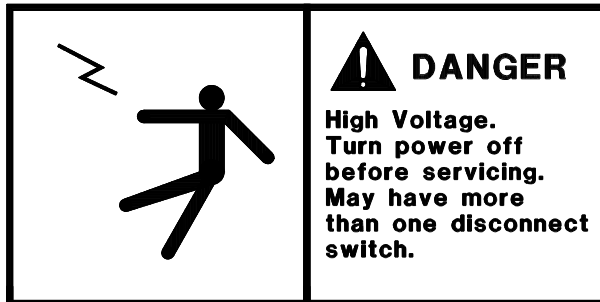

*This label is attached to the cabinet power cord label and on the wiring channel.*

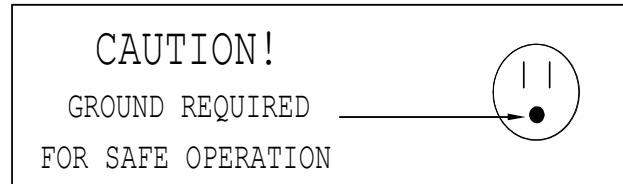

*This label is located on top of the electrical control on models with a power cord.*

## PRE-INSTALLATION INSTRUCTIONS

### INSPECTION FOR SHIPPING DAMAGE

You are responsible for filing all freight claims with the delivering truck line. Inspect all cartons and crates for damage as soon as they arrive. If damage is noted to shipping crates or cartons or if a shortage is found, note this on the bill of lading (all copies) prior to signing.

If damage is discovered when the cabinet is uncrated, immediately call the delivering truck line and follow up the call with a written report indicating concealed damage to your shipment. Ask for an immediate inspection of your concealed damage item. Crating material must be retained to show the inspector from the truck line.



# INSTALLATION INSTRUCTIONS

## GENERAL INSTRUCTIONS

1. Be sure the equipment is properly installed by competent service people.
2. Keep the equipment clean and sanitary so it will meet your local sanitation codes.
3. Rotate your stock so that older stock does not accumulate. This is especially important for ice cream. A "First-In, First-Out" rotation practice will keep the products in good salable condition.
4. Do not place product in the case when it is soft or partially thawed. Also, product should not be put in the case for at least 6 hours after it is started.
5. Stock cases as quickly as possible, exposing only small quantities to store temperatures for short periods of time.
6. When replacing burned out fluorescent tubes, be sure that the electrical power to the lighting circuit is turned off.

## NOTICE TO STORE OWNERS / MANAGERS

**Moisture or liquid around or under the cabinet is a potential slip/fall hazard for persons walking by or working in the general area of the cabinet. Any cabinet malfunction or housekeeping problem that creates a slip/fall hazard around or under the cabinet should be corrected immediately.**

If moisture or liquid is observed around or under a Master-Bilt® cabinet, an immediate investigation should be made by qualified personnel to determine the source of the moisture or liquid. The investigation should determine if the cabinet is malfunctioning or if there is a drainpipe leaking.

## ELECTRICAL



### WARNING

**Before servicing electrical components in the case, make sure all power to case is off. Always use a qualified technician.**



### NOTICE

**For models with electronic ballast only:**

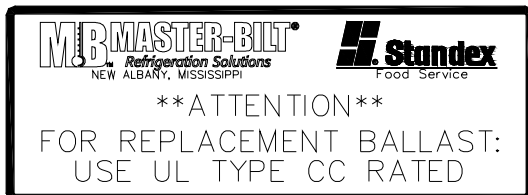

**For replacement ballast, use only ballast that complies with UL Type CC rating if unit is equipped with electronic ballast.**



## MECHANICAL

**Remove grille and check refrigeration lines to see that they are free (not touching each other or compressor). Spin condenser fan blade to see that it is free.**

Check that all service valves are open. The picture below is Master-Bilt's standard DD-Unit. The compressor is hermetic, it is internally spring mounted and ready to run.

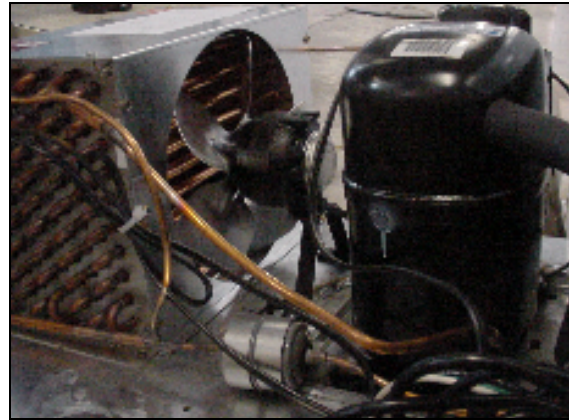

Hermetic Compressors

Remove cabinet from crate base and slide into location. Cabinet must be level from side to side and front to back.

To comply with Sanitation requirements the cabinet must be mounted on legs (6" high min.) or casters or the base must be sealed to the floor with an N.S.F. listed silicone sealant.

## STARTUP

Uncoil the lead cord and pass it through the hole provided in the grill. While the cabinet is in operation, check the voltage draw and the amperage draw versus this rating on the nameplate. Voltage should be checked at the compressor terminals while the compressor is initially starting. The unit is designed to operate at +/- 10% of 115 volts, 60 cycle, single phase. This means that the voltage should be between 103 and 126.5 volts.

After the cabinet has pulled down in temperature to approximately 0°F at load line, check the thermostatic control by turning it to its warmest position. This should shut the compressor off. Also check that the double pole single throw switch turns the compressor off only. A separate 20 amp. fuse circuit for each cabinet is recommended to avoid the possibility of other appliances on a circuit from overloading and causing a malfunction. Make sure that the electrical service is grounded upon installation.

## TEMPERATURE CONTROL

The DD cabinet has a temperature control that is adjustable from #1 (warmest setting) to #9 (coldest setting). Turn the control knob in line with the punch mark to the desired setting. The temperature control is located near the condensing unit at the bottom of the cabinet.

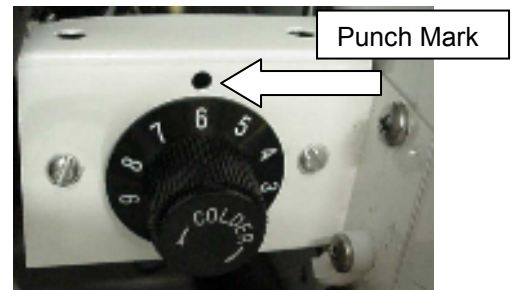



## CLEANING

**WARNING: DO NOT REMOVE FROST WITH A KNIFE, PICK, OR SHARP OBJECTS. DO NOT USE ABRASIVE CLEANERS OR CAUSTIC CLEANERS OR SCOURING PADS**

Every 30 to 60 days (depending on frost accumulation), the cabinet should be emptied, warmed up, and wiped down using a solution of 1 teaspoon of baking soda with 1 quart of water. This solution will help eliminate odors. Do not use strong soaps or detergents as they leave odors that can contaminate your product. The **DD** line cabinets are equipped with a floor drain that exits out the lower rear of the cabinet. This exit has a convenient garden hose fitting.

If it is not convenient to turn the power off the cabinet, lay a piece of plastic sheeting on the floor of the cabinet and scrape the frost off walls using a plastic scraper. Do not use metal scrapers. This will damage the interior paint of the cabinet.

### Lid Removal and Cleaning

The lid can be removed by lifting up and out (see picture). The lid is a high-impact plastic. Wash with warm soapy water or non-abrasive detergent to avoid scratching.

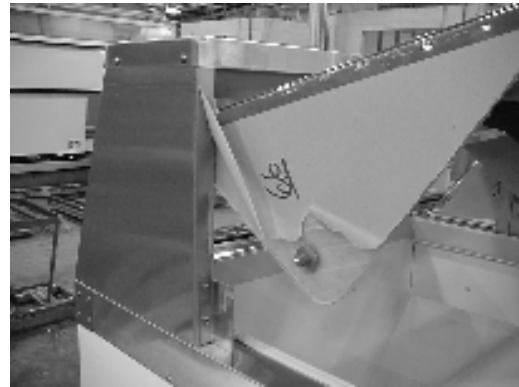

The

### Can Holder Assembly Removal and Cleaning (Optional)

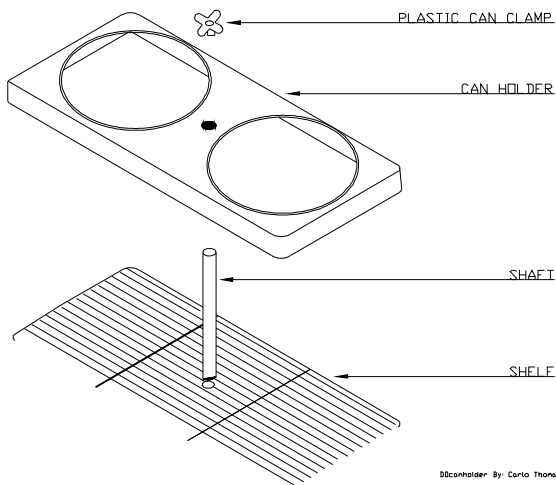

Remove plastic can clamp by screwing knob off the threaded shaft. Wash the can holder and can clamp with a non-abrasive detergent to maintain sanitary gloss. Remove the shaft by loosening the wing nut and unscrewing the shaft from the shelf. Wash the shaft and shelf using a non-metallic brush.

### Frost-Shield Removal and Cleaning (optional)

When the frost-shields accumulate approximately 1/2 to 1 inch of frost (about two to three days), remove it by lifting up to disengage from the keyhole slot. Remove the frost by holding under running water until clean. Dry and replace the frost-shield by engaging screws at the big end of the keyhole and push down.

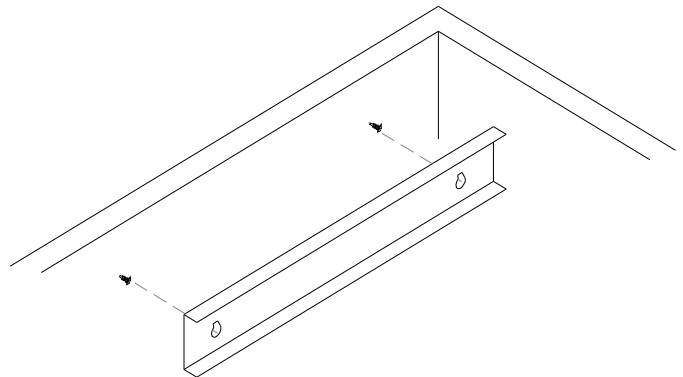

## OPERATION CONDITIONS AND PRESSURES

With room ambient temperature of +80 °F and cold cabinet (unit cycling on control):

### DD-66 & DD-88 with R-404a

Suction pressure – 6 to 8 psig.

Head pressure – 240 to 260 psig.

If room ambient is low, 60 °F or lower, then the suction pressure could be as low as 4 psig. Temporary block the condenser coil to raise head pressure to 240 psig in order to verify proper charge and a suction pressure of 6psig to 8 psig. Remove blockage after pressure check.

### DD-26 & DD-46 with R-134a

Suctions pressure –5 to –8 inches vacuum

Head pressure 105 to 110 psig

If room abient is below 70 °F temporarily block the condenser coil to raise the head pressure to 105 psig and recheck suction pressure. Add R-134a if suction pressure is lower than –8 inches of vacuum.

## SERVICE INSTRUCTIONS (Trouble Shooting Guide)

1. High head pressure and high back pressure:
  - A. Condenser coil clogged or restricted.
  - B. Condenser fan motor defective.
  - C. Air in the system.
  - D. Refrigeration overcharge.
2. Low back pressure and low head pressure:
  - A. Capillary tube restriction.
  - B. Refrigerant undercharged.
  - C. Leak in system.
  - D. Moisture in system.
3. Pressures normal – cabinet warm:
  - A. Refrigerant undercharged.
  - B. Thermostat set too warm.
4. Compressor starts and runs – but cycles on overload:
  - A. Low voltage.
  - B. Overload protector defective.
  - C. High head pressure (see#1).
5. Compressor will not start – hums, but cycles on overload:
  - A. Low voltage.
  - B. Relay defective.
  - C. Overload defective.
  - D. High head pressure (see #1).
6. Cabinet sweating:
  - A. High ambient humidity.
7. Special service situations

If moisture or liquid is observed around or under a Master-Bilt<sup>®</sup> cabinet, an immediate investigation should be made by qualified personnel to determine the source of moisture or liquid. The investigation made should determine if the cabinet is malfunctioning or if there is a simple housekeeping problem.

Moisture or liquid around or under a cabinet is a potential slip/fall hazard for persons walking by or working in the general area of the cabinet.

Any cabinet malfunction or housekeeping problem that creates a slip/fall hazard around or under a cabinet should be corrected immediately.

## MASTER-BILT PART NUMBERS

The table below gives Master-Bilt® part numbers. Use this chart when ordering replacement parts for your

### DD Standard, Low Glass and Curved Glass Models.

Description	DD-26(CG)(-L)	DD-46(CG)(-L)	DD-66(CG)(-L)	DD-88(CG)(-L)
Ballast, 18"	23-01709	23-01709	23-01709	23-01709
Ballast, 36"	23-01709	23-01709	23-01709	23-01709
Bulb Shield, 18"	25-01273		25-01273	
Bulb Shield, 36"		25-01274	25-01274	25-01274
Capillary Tube	11-01306	11-01306	11-01450 (2 REQ)	11-01450 (2 REQ)
Compressor		03-14761	03-14902	03-14902
Condenser Coil		07-13253	07-13296	07-13296
Condenser Fan Blade		15-13093	15-13093	15-13093
Condenser Fan Motor		13-00311	13-00311	13-00311
Condenser Fan Motor Bracket		13-00754	13-00754	13-00754
Condensing Unit	01-01494			
Drier	09-09308	09-09171	09-09171	09-09171
Fluorescent Lamp, 18"	23-00329		23-00329	
Fluorescent Lamp, 36"		23-00325	23-00325	23-00325
Gasket		37-00497	37-00498	37-00499
Glass, Tempered (Curved Glass)	31-01543	31-01199	31-01193	31-01192
(Low Glass Model)	31-02308 31-02481	31-02124 31-02482	31-02309 31-02483	31-02310 31-02484
Lampholder w/ Starter Socket	23-01127	23-01127	23-01127	23-01127
w/o Starter Socket	23-01128	23-01128	23-01128	23-01128
LED KIT (if provided)		23-01740	23-01739	23-01738
Lid Assembly	059-145A	062-145A	060-145A	061-145A
Light Switch	23-50793	23-50793	23-50793	23-50793
Power Switch	19-01090	19-01090	19-01090	19-01090
Shelf, Wire	33-01413	33-01413	33-01413	33-01413
Starter, 18"	23-01092		23-01092	
Starter, 36"		23-01093	23-01093	23-01093
Temperature Control	19-13607	19-13607	19-13607	19-13607
Wire Harness (126" Power Cord)	21-00585	21-00585	21-00585	21-00585

## Accessories

Description	DD-26(CG)(-L)	DD-46(CG)(-L)	DD-66(CG)(-L)	DD-88(CG)(-L)
Can Holders –Includes White Can Covers	A059-200300	A062-20300	A060-20300	A061-20300
Can Covers Clear White	44-00984 44-00973	44-00984 44-00973	44-00984 44-00973	44-00984 44-00973
Casters Set (4), 3” Dia. Set (6), 3” Dia.	A062-11140	A062-11140	A061-11140	A061-11140
Condiment Holders and Food Pan Display	A059-10650	A062-10650	A060-10650	A061-10650
Individual Containers for Condiment Holders (Clear)	44-01020	44-01020	44-01020	44-01020
Dipper Well w/Installation Kit	A060-20400	A060-20400	A060-20400	A060-20400
Frost Shield (Patented) <b>Master-Bilt Exclusive</b>	A059-11150	A062-11150	A060-11150	A061-11150
Legs 6” leg kit	A062-11170	A062-11170	A061-11170	A061-11170
Lid Locking Kits – Less Locks	A059-11129	A059-11129	A060-11129	A060-11129
DDN Flavor Tags	A062-20225	A062-20225	A062-20225	A062-20225

## SALE AND DISPOSAL

### OWNER RESPONSIBILITY

If you sell or give away your Master-Bilt® cabinet you must make sure that all safety labels and the Installation - Service Manual are included with it. If you need replacement labels or manuals, Master-Bilt will provide them free. Contact the customer service department at Master-Bilt at (800) 684-8988.

The customer service department at Master-Bilt should be contacted at the time of sale or disposal of your cabinet so records may be kept of its new location.

If you sell or give away your Master-Bilt® cabinet and you evacuate the refrigerant charge before shipment, Master-Bilt recommends that the refrigerant charge be properly recovered in compliance with section 608 of the Clean Air Act effective November 1995 and in accordance with all applicable local, regional, or national standards.

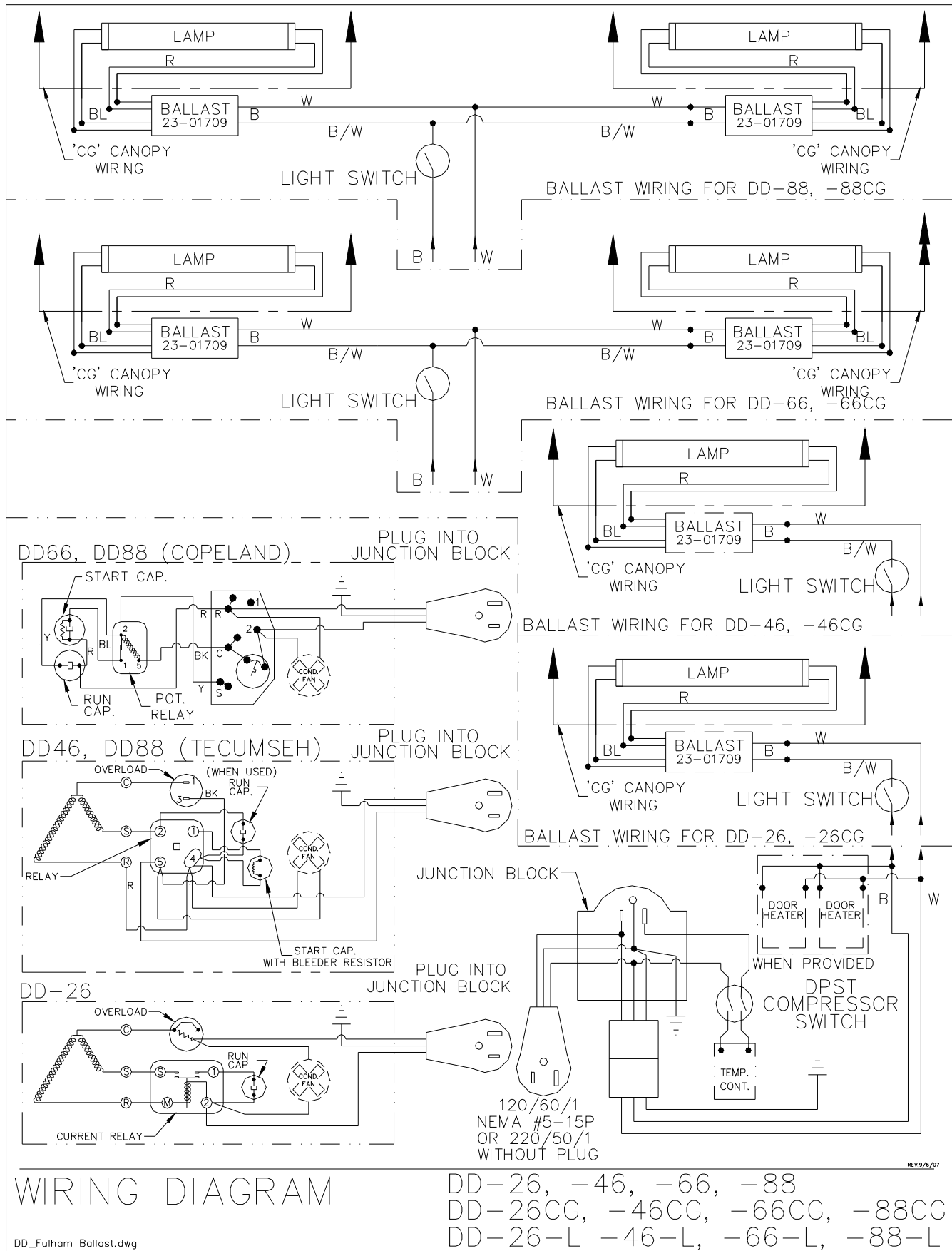

REV 9/6/07

DD\_Fulham Ballast.dwg



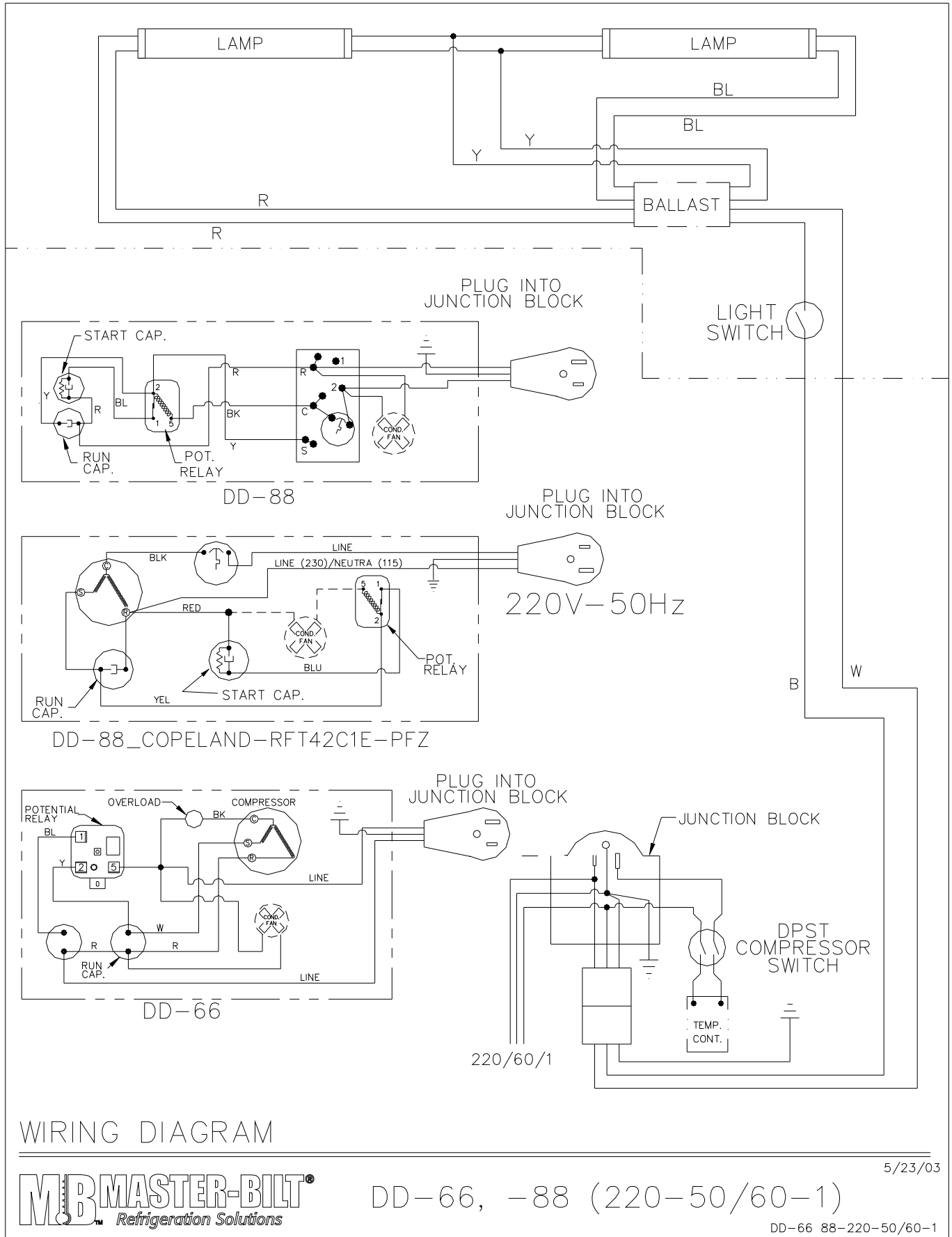

LIGHT WIRING FOR DD-88, DD-66

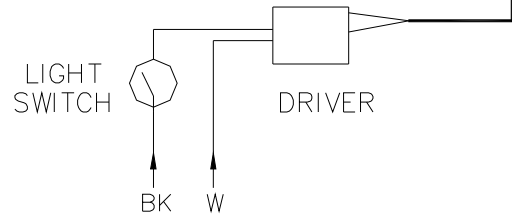

LIGHT WIRING FOR DD-26, DD-46

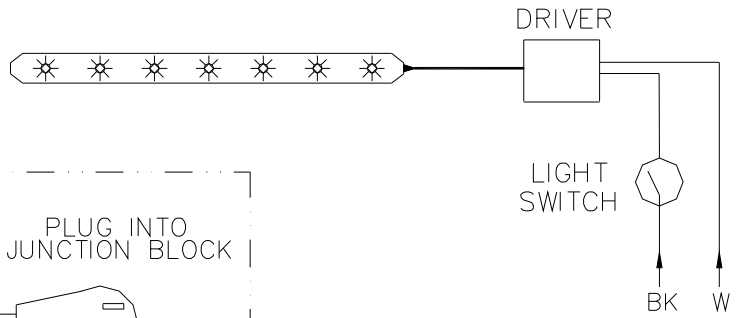

DD66, DD88 (COPELAND)

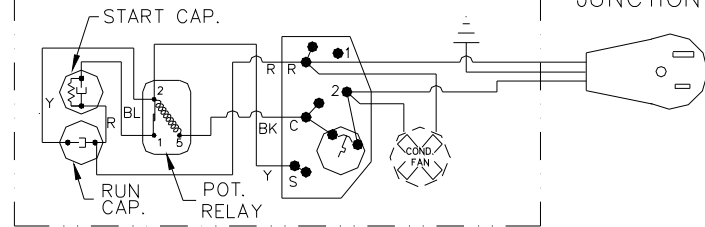

PLUG INTO JUNCTION BLOCK

DD46, DD88 (TECUMSEH)

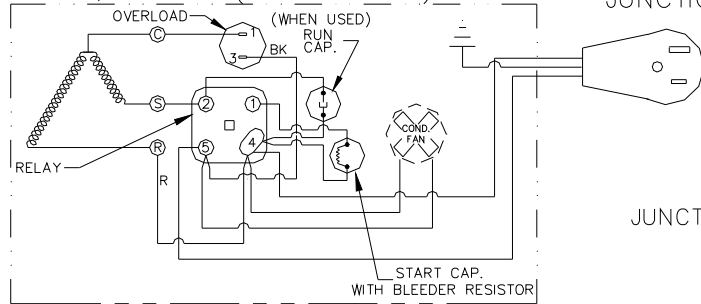

PLUG INTO JUNCTION BLOCK

DD-26, DD-46 (COPELAND)

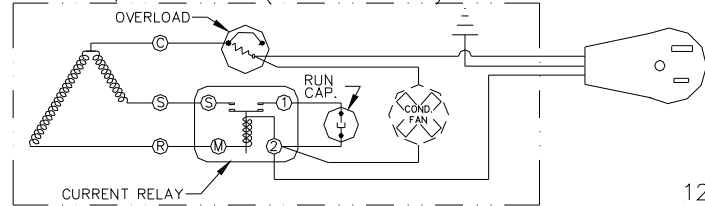

PLUG INTO JUNCTION BLOCK

JUNCTION BLOCK

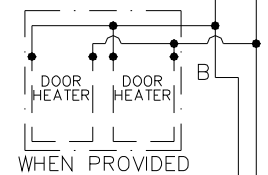

DPST COMPRESSOR SWITCH

TEMP. CONT.

120/60/1  
NEMA #5-15P  
OR 220/50/1  
WITHOUT PLUG

BK  
W

# WIRING DIAGRAM

DD-26, -46, -66, -88  
DD-26CG, -46CG, -66CG, -88CG  
DD-26-L -46-L, -66-L, -88-L

DD\_ITC-LED.dwg

01-24-11

