

Cafe Barstool

ASSEMBLY INSTRUCTIONS



LANCASTER™
TABLE & SEATING

REQUIRED TOOLS: • Screwdriver

CONTENTS:

A Frame 1/PC

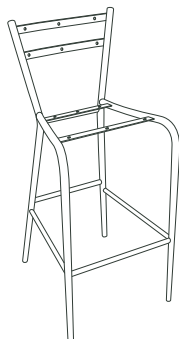

B Backrest 1/PC

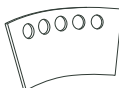

C Seat 1/PC



HARDWARE:

D Backrest Screws 6/PC



E Seat Screws 6/PC



NOTES:

1. Inspect all pieces for damage before assembly. Do not assemble if any pieces are broken or damaged. Ensure you have all required pieces before assembly.
2. Power drill is optional for assembly.

STEP 1

Align backrest (B) on top part of frame (A) between the two poles. Backrest should fit snug between the two frame poles.

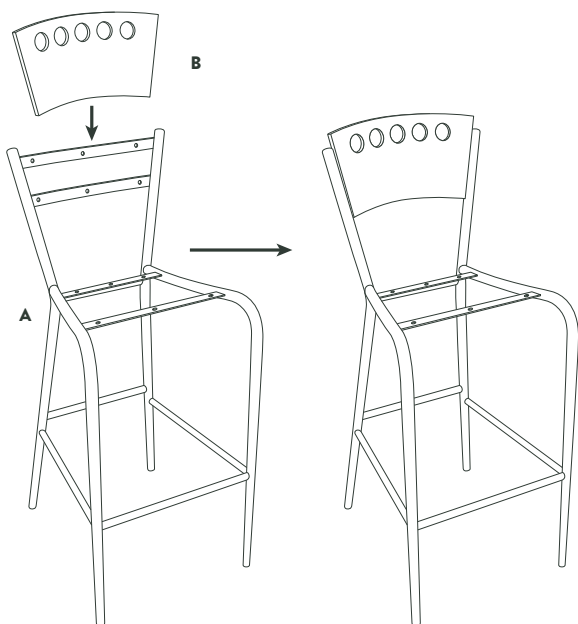

STEP 2

Attach backrest (B) to frame (A) with six backrest screws (D) using a screw driver or drill.

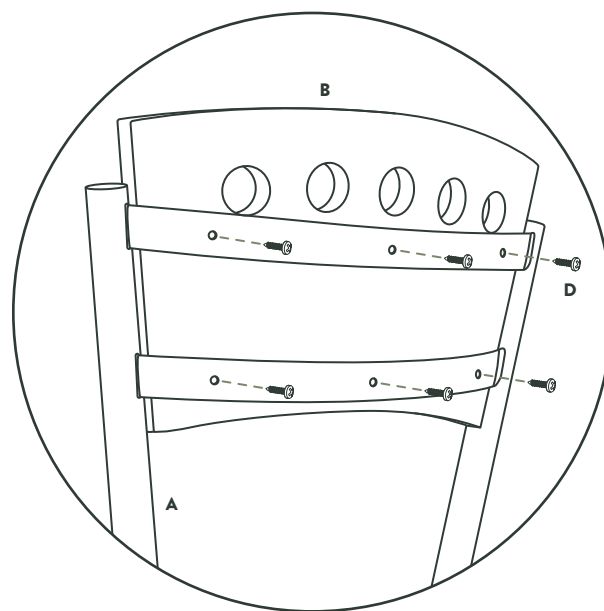

Cafe Barstool

ASSEMBLY INSTRUCTIONS



LANCASTER™
TABLE & SEATING

STEP 3

Place frame (A) on its back. Center seat (C) on the frame (A) with six screw holes. Push the seat against the frame, ensuring the front of the seat is parallel to the front of the frame.

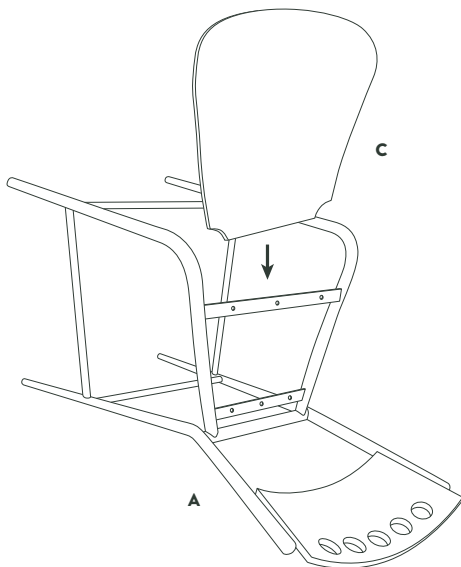

STEP 4

Attach seat (C) to frame (A) with six seat screws (E) using a screwdriver or power drill.

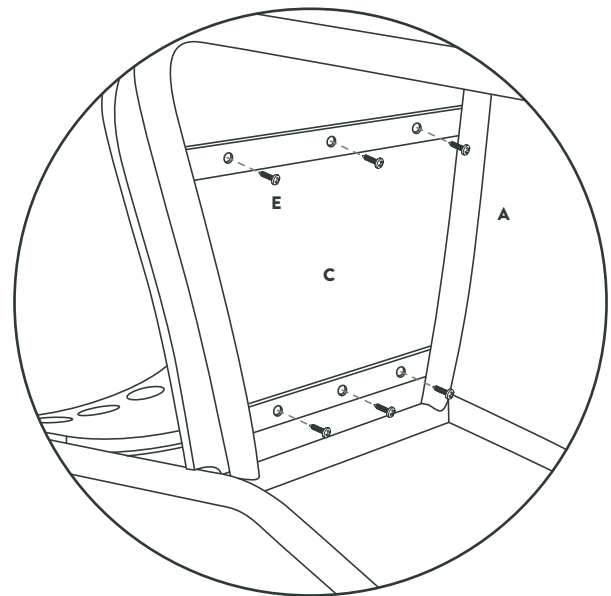

STEP 5

Ensure all screws are tightened fully.
Stand chair upright for usage.

