

Ladderback Swivel Barstool

ASSEMBLY INSTRUCTIONS



LANCASTER™
TABLE & SEATING

PARTS LIST

A Seat 1/PC



C Seat Screws 6/PC



E Bolts 4/PC



G Wrench 1/PC



B Seat Frame 1/PC

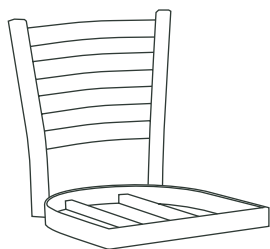

D Base with Swivel Plate 1/PC

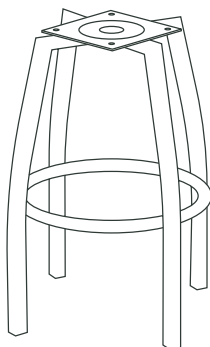

F Nuts 4/PC



H Allen Key 1/PC

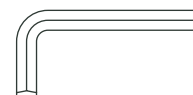

NOTES

1. Before starting, make sure you have all the required pieces.
2. A screwdriver is required for assembly (not included). A drill is optional for easier assembly.
3. Use caution when assembling the base as the swivel plate has moving parts.

STEP 1

To Start, place the seat (A) upside down on a table and set the seat frame (B) upside on top of the cushion. Be sure to center the frame on top of the cushion. The front edge of the cushion should be parallel to the front edge of the seat frame.

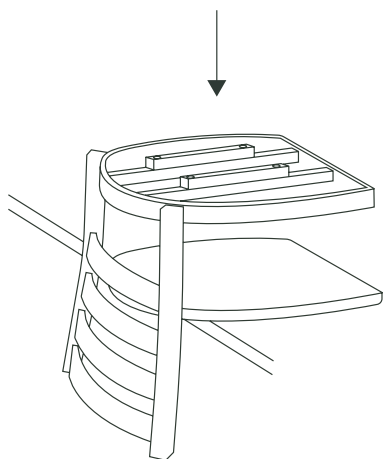

STEP 2

Using a screwdriver or drill, attach the 6 seat screws (C) and secure the cushion to the frame through the screw holes on the seat frame.

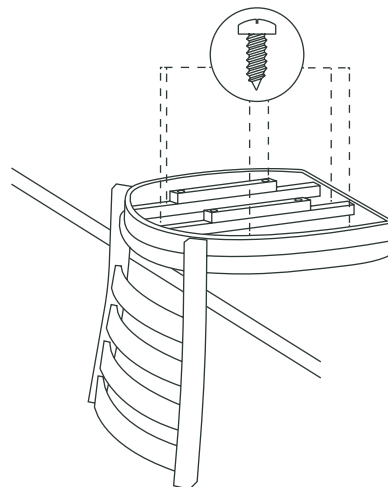

Ladderback Swivel Barstool

ASSEMBLY INSTRUCTIONS



LANCASTER™
TABLE & SEATING

STEP 3

Next, rotate the swivel plate on top of the base (D) so that all four holes are accessible.

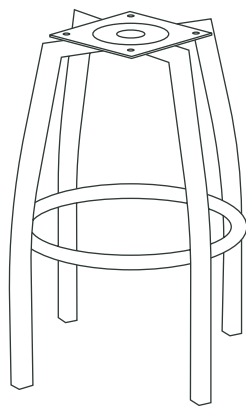

STEP 4

Flip the base upside down and position it on top of the seat frame and seat. Align the holes in the swivel plate with the frame. Next, insert a bolt (E) through a hole in the swivel plate and secure with a nut (F). Use the wrench (G) to hold the nut securely while you tighten the bolt with the allen key (H). Repeat for all four holes in the swivel plate.

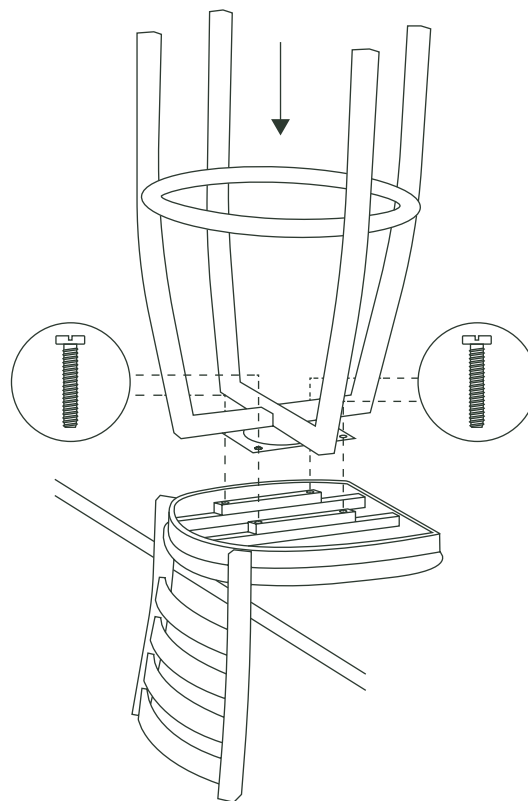

STEP 5

Ensure all bolts and screws are tightened securely. Carefully flip the stool and turn it right side up.

