

# Ladderback Chair

## ASSEMBLY INSTRUCTIONS



LANCASTER™  
TABLE & SEATING

### PARTS LIST:

**A** Frame 1/PC

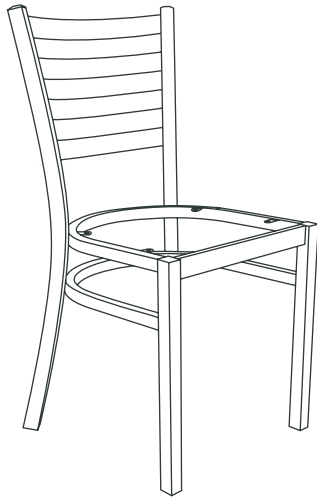

**B** Wood Seat 1/PC

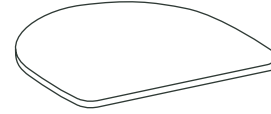

**C** Screws 4/PC



**REQUIRED TOOLS:** Screwdriver

### NOTES:

1. Inspect all pieces for damage before assembly. Do not assemble if any pieces are broken or damaged. Ensure you have all required pieces before assembly.
2. Power drill is optional for assembly.
3. There are two options for assembly, please reference both steps for your preference.

### STEP 1

**Option 1:** Place chair frame (A) on its back. Center seat (B) on the frame with four screw holes, push the seat against frame, ensure front of seat is parallel to the front of the frame.

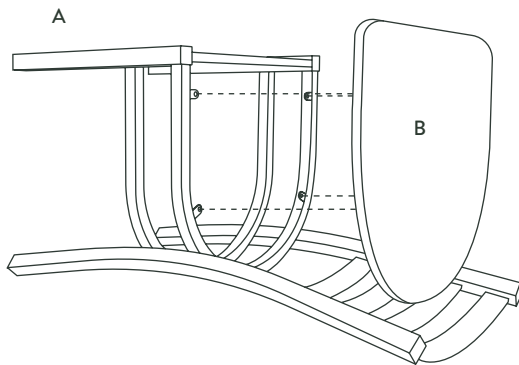

OR

**Option 2:** Place seat (B) upside down on a flat surface, preferably a table. Align chair frame (A) on top of seat (B). Center seat with four screw holes on frame, push seat against the back of the frame and ensure front of seat is parallel to the front of the frame.

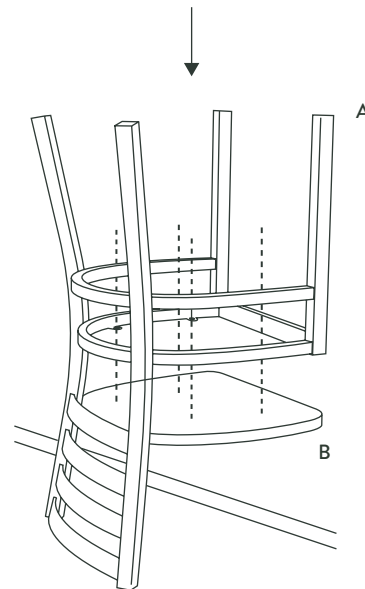

# Ladderback Chair

ASSEMBLY INSTRUCTIONS



LANCASTER™  
TABLE & SEATING

## STEP 2

Attach seat (B) to frame (A) with four screws (C) using a screwdriver or powerdrill.

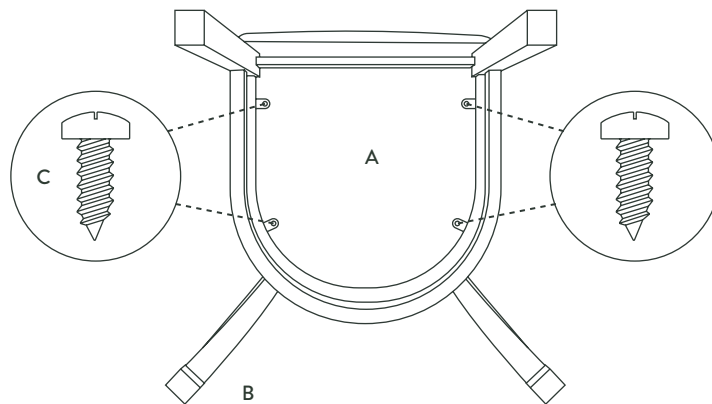

## STEP 3

Ensure all screws are tightened fully.  
Stand chair upright for usage.

