

Standard Height High Chair

ASSEMBLY INSTRUCTIONS



IMPORTANT: REFER TO SAFETY WARNINGS ON PAGE 3 BEFORE ASSEMBLY.



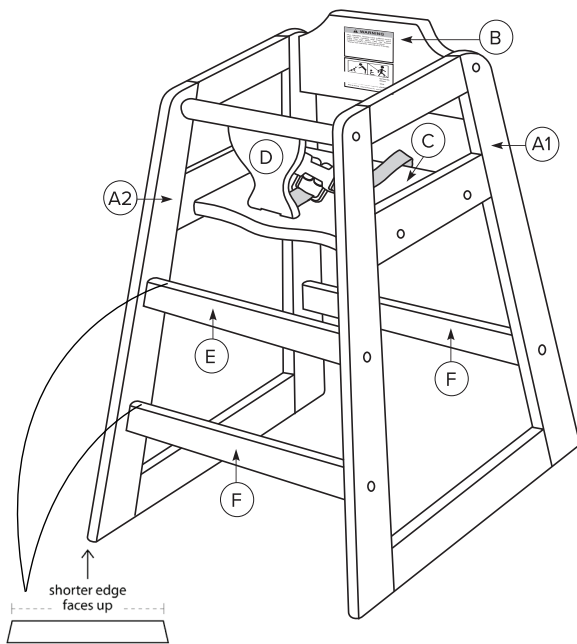

ASSEMBLED DIAGRAM:



PARTS LIST:

(A1) Right Frame	1
(A2) Left Frame	1
(B) Back Panel	1
(C) Seat	1
(D) Crotch Panel	1
(E) Foot Rest	2
(F) Stretcher	2

HARDWARE:

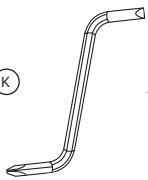
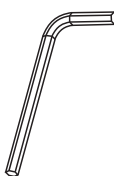
- (G)  Connector Bolt
18 pcs
2 extra bolts included
- (H)  Split Washer
18 pcs
2 extra washers included
- (I)  Split Washer for Wood Bolt
3 pcs
2 extra split washers included
- (J)  Wood Bolt
3 pcs
2 extra bolts included
- (K)  Double-ended Allen Key
1 pc
- (L)  Allen Key
1 pc

NOTES:

1. Inspect all pieces for damage upon receipt and before assembly. Do not assemble or use if any pieces are broken or damaged.
2. Put a washer on every bolt.
3. You may need a screwdriver to tighten for easier assembly. **DO NOT** use a powerdrill during assembly.

STEP 1

Lay out all pieces and unwrap them. Ensure all pieces are included and inspect contents for damage before assembly.

Standard Height High Chair

ASSEMBLY INSTRUCTIONS



LANCASTER
TABLE & SEATING

STEP 2

Insert the wood bolt (J) with split washer (I) through the hole under the seat and then through the hole in the belt. Use the provided double-ended allen key (K) to tighten the wood bolt after inserting into the crotch panel (D). Refer to the diagram below:

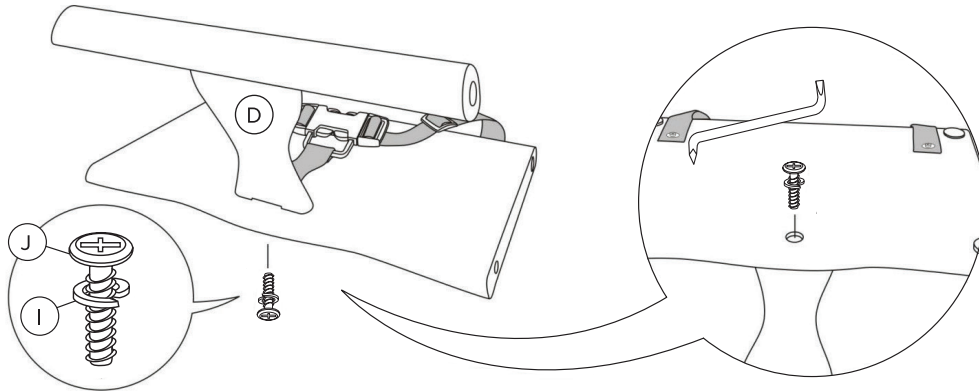

STEP 3

Join the right frame (A1) with parts (B, C, and D). Insert connector bolts (G) with split washers (H) using the allen key (L) to join them but **DO NOT TIGHTEN** completely. Join the left frame (A2) with parts (B, C, and D) but **DO NOT TIGHTEN COMPLETELY**.

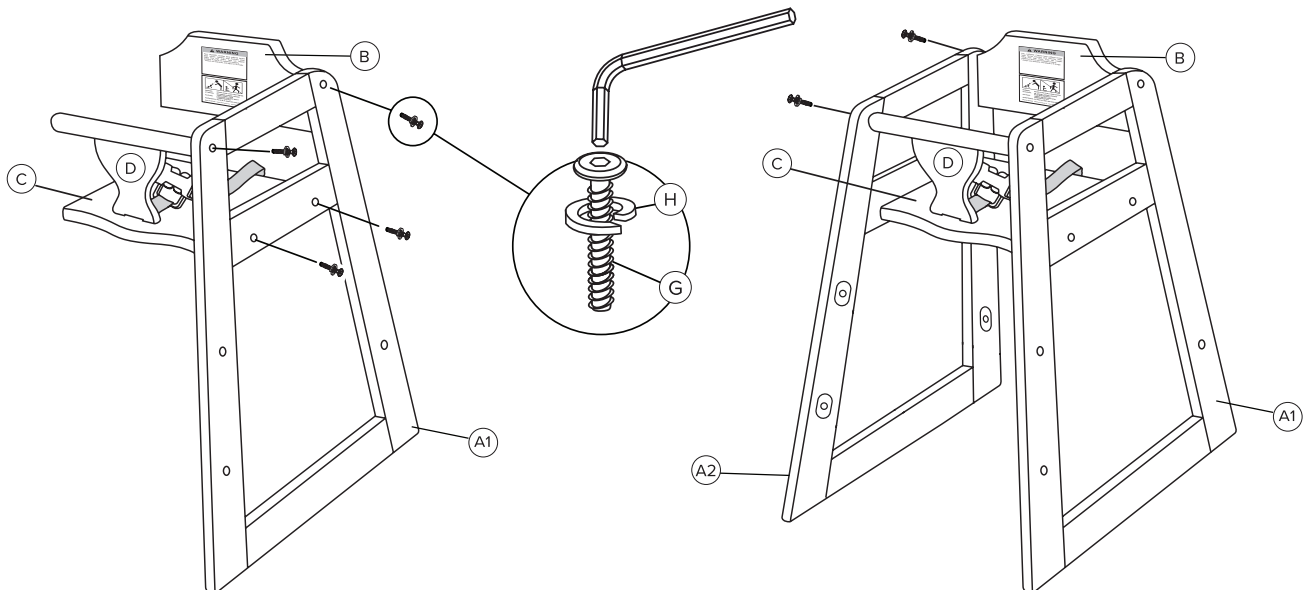

Standard Height High Chair

ASSEMBLY INSTRUCTIONS



STEP 4

Tap foot rest (E) into its slots. Install bolts (G) with split washers (H) using allen key (L). Ensure the angle cuts on ends are properly aligned with the shorter width at the top. Tap in stretchers (F) and install remaining connector bolts with washers. Check chair balance and tighten all bolts to complete assembly.

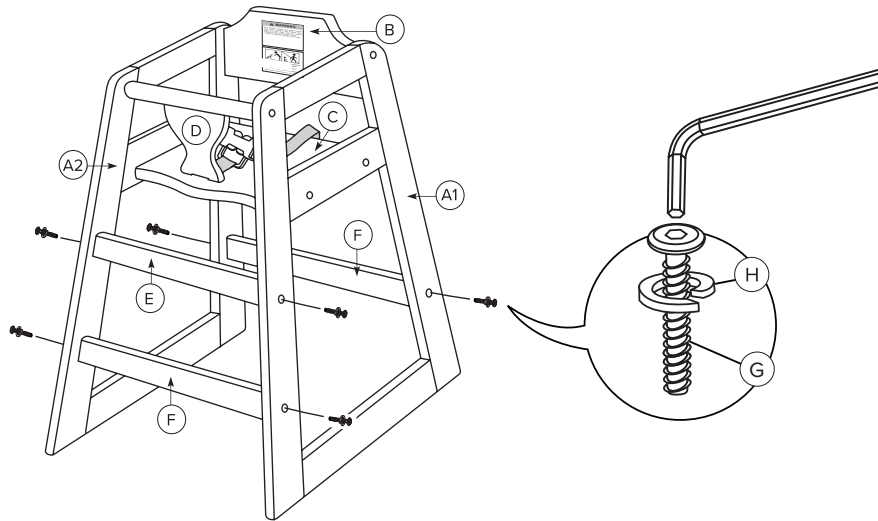

CLEANING AND MAINTENANCE:

1. Periodically tighten bolts as needed.
2. Wipe chair with slightly damp cloth.



! WARNING !

FALL HAZARD: Children have suffered severe head injuries including skull fractures when falling from high chairs. Falls can happen suddenly if child is not restrained properly.

- Only children capable of sitting upright, unassisted should use this high chair.
- Always use restraints and adjust to fit snugly.
- Stay near and watch child during use.
- Discontinue use of this chair if child is a maximum weight of 35lbs/15.8kgs.
- The child should be secured in the high chair at all times by the restraint system.

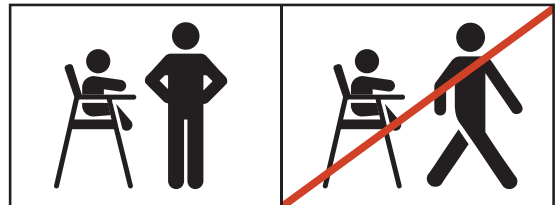

WARNING: NEVER LEAVE CHILD UNATTENDED

ATTENTION: NE JAMAIS LAISSER L'ENFANT SANS SURVEILLANCE

ACHTUNG: LASSEN SIE DAS KIND NICHT UNBEAUF SICHTIGT

ADVERTENCIA: NO DEJE AL NINO SIN VIGILANCIA

164HIGHCBK / 164HIGHCDB / 164HIGHCMO / 164HIGHCNAT / 164HIGHCWIN / 164HIGHCKDBK / 164HIGHCKDDB / 164HIGHCKDMO / 164HIGHCKDNT / 164HIGHCKDWN / 164HIGHBKDBK / 164HIGHBKDDB / 164HIGHBKDMA / 164HIGHBKDNA / 164HIGHBKDWA / 274HCBKWTASM / 274HCGYWTASM / 274HCHRWHLBK / 274HCHRWHLGY / 274HCGYTRASM / 274HCBKTRASM / 274HCHAIRBK / 274HCHAIRGY

Lancaster Table and Seating, 2205 Old Philadelphia Pike, Lancaster, PA 17602 • 1-800-942-0412