



## Electric Griddles



**Models:** EG16N, EG24N, EG30N, EG36N

10/2018

***Please read and keep these instructions. Indoor use only.***

## Specifications

All units come with a 6 ft. commercial cord except EG36N which must be hard wired

Model	Voltage	Power	Dimensions (LxWxH)	Temp. Range	Net Wt.	Shipping Wt.	Plug Type
EG16N	120V AC	1750W	16" x 19.75" x 9.5"	120°F - 570°F	52 lbs.	62 lbs.	NEMA 5-15P
EG24N	208V/240V	2675/3560W	24" x 19.75" x 9.5"	120°F - 570°F	80 lbs.	90 lbs.	NEMA 6-20P
EG30N	208V/240V	3375/4500W	30" x 19.75" x 9.5"	120°F - 570°F	87 lbs.	110 lbs.	NEMA 6-20P
EG36N	208/240V	7488/10080W	36" x 19.75" x 9.5"	120°F - 570°F	201 lbs.	218 lbs.	WIRING

## Safety

1. Ensure that the power supply you are using is adequate for continual griddle use and the voltage is correct.
2. Allow at least 8" of clearance around all sides.
3. Unplug the unit when not in use and before cleaning.
4. Do not immerse unit, cord or plug in liquid at any time.
5. Do not operate unattended.
6. Do not use this unit for anything other than its intended use.
7. Do not use outdoors.
8. Always use on a firm, dry and level surface.
9. Do not use if unit has a damaged cord or plug, in the event the appliance malfunctions, or has been damaged in any manner.
10. Any incorrect installation, alterations, adjustments and/or improper maintenance can lead to property loss and injury. All repairs should be done by authorized professionals.

## Instructions for First Time Use

**There is a thin layer of wax paper on top of the grill plate that must be removed prior to using the griddle.**

In order to protect the plates of your new grill during transportation, a layer of food-safe oil was coated on the surface prior to shipment. This oil is harmless, but must be removed before you begin to use. To remove, preheat the grill until the oil liquifies. Next, carefully wipe away the melted oil with a clean, soft cloth. Once all of the oil is removed you can begin to use your grill.

## Operation

1. Plug the power cord into the appropriate outlet. The red "Power" light will illuminate.
2. Set the desired temperature by turning the rotary temperature knob clockwise. The heating element will begin to heat up and the green "Heating" light will illuminate.
3. When the temperature reaches the desired setting, the green "Heating" light will cycle on and off with the heating element to maintain the set temperature.
4. For best results, allow the unit to preheat for 15 minutes before placing food on cooking surface.
5. Turn temperature knob to the "Off" position to turn the green "Heating" light and heating element off. You must unplug the unit for the red "Power light" to turn off.

## Transportation And Maintenance

During transportation, the machine should be handled with care.

## Cleaning

Unplug the unit and allow it to cool before cleaning. Do not use abrasive cleaners or scouring pads. If soap or chemical cleaners are used, be sure they are completely rinsed away with clear water immediately after cleaning. Chemical residue could damage or corrode the surfaces of the unit.



Attack tough grease, oil, and carbon with this ready to use decarbonizer and degreaser. Its unique formula is designed to clean ovens, grills, hoods and a wide variety of other surfaces.

## Limited Warranty

All equipment, which is sold under Avantco trademark and used for commercial purpose is warranted against defects in materials and workmanship. The warranty runs for one year from the time of purchase and is for the benefit of the original purchaser only. All other Warranties, Expressed or Implied, Statutory or Otherwise, including Without Limitation any implied Warranty of Merchantability or Fitness for Purposes are excluded. The Seller shall in no event be liable for direct, indirect or consequential damages in connection with Avantco commercial products.

This warranty is not effective if damage occurs because of accident, carelessness, improper installation, lack of proper set – up, supervision when required or if the equipment is installed or operated in any manner contrary to the installation and operating instructions. Work performed by unauthorized personnel or unauthorized service agencies voids this Warranty.

This warranty does not apply to, and Avantco is not responsible for any warranty claims on products sold or used outside of the contiguous United States.

This equipment is intended for commercial use only. Warranty is void if equipment is installed in anything other than commercial applications.

## Exploded Parts Diagram

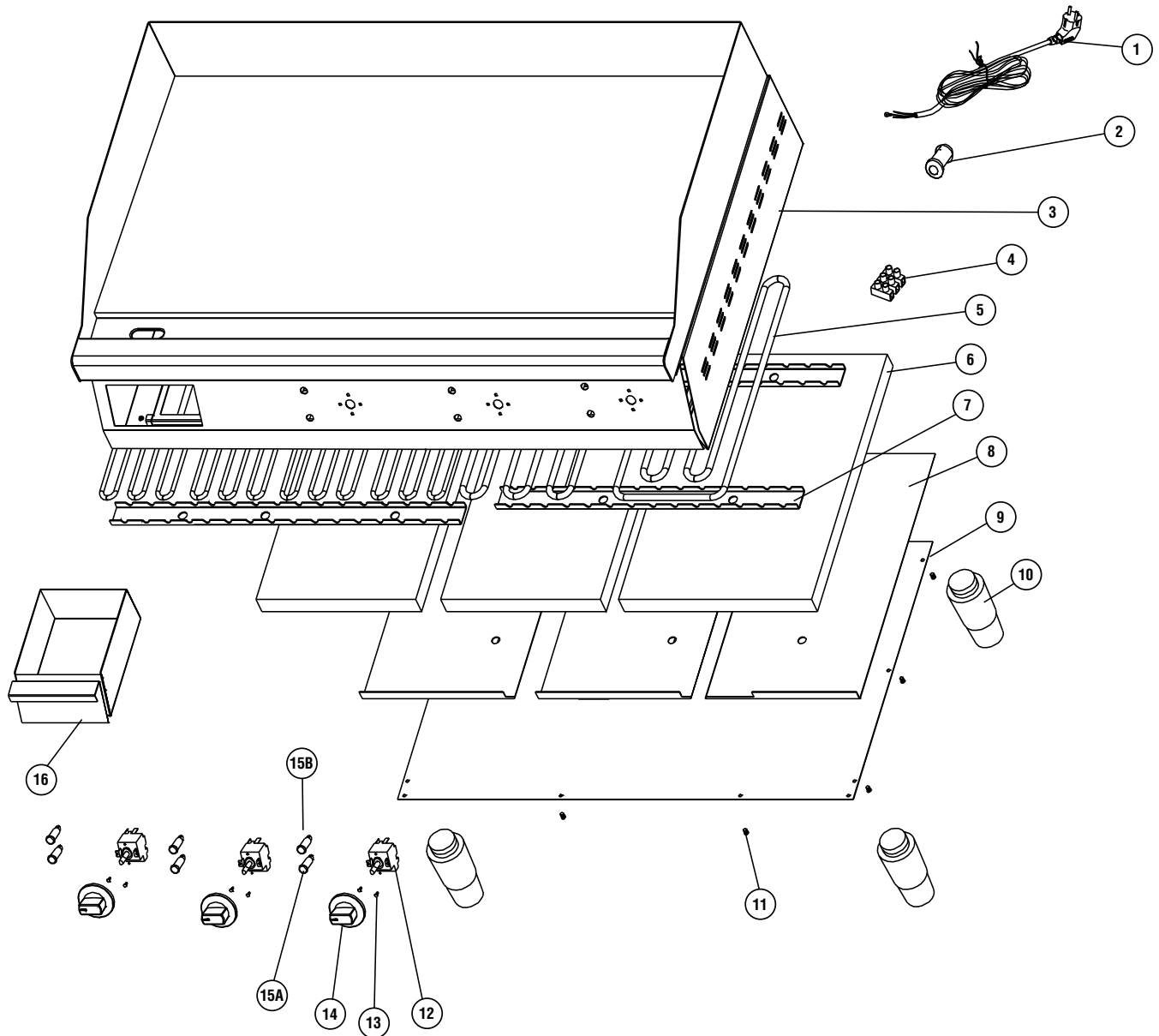

<b>Parts Key</b>		
<b>Parts Diagram #</b>	<b>Part Name</b>	<b>Replacement Part Item #</b>
1	Power Cord	177COPCORD (EG16N), 177COPCORD2 (EG24N & EG30N)
2	Power Cord Clip	
3	Body	
4	Terminal	177EGTERMNL1 (EG16N), 177EGTERMNL2 (EG24N, EG30N, EG36N)
5	Heating Element	177EGELEM16 (EG16N), 177EGELEM24 (EG24N), 177EGELEM30 (EG30N), 177EGELEM36 (EG36N)
6	Insulation	
7	Heating Element Holder	
8	Insulation Board	
9	Bottom Plate	
10	Foot	177EGLEG
11	Bottom Plate Screws	
12	Thermostat	177EGTHERM2
13	Thermostat Screws	
14	Thermostat Knob	177EGKNOB
15A	Red Power Light	177COPLIGHT
15B	Green Working Light	177COWLIGHT
16	Grease Tray	177EGTRAY

## Circuit Diagrams

### EG16N

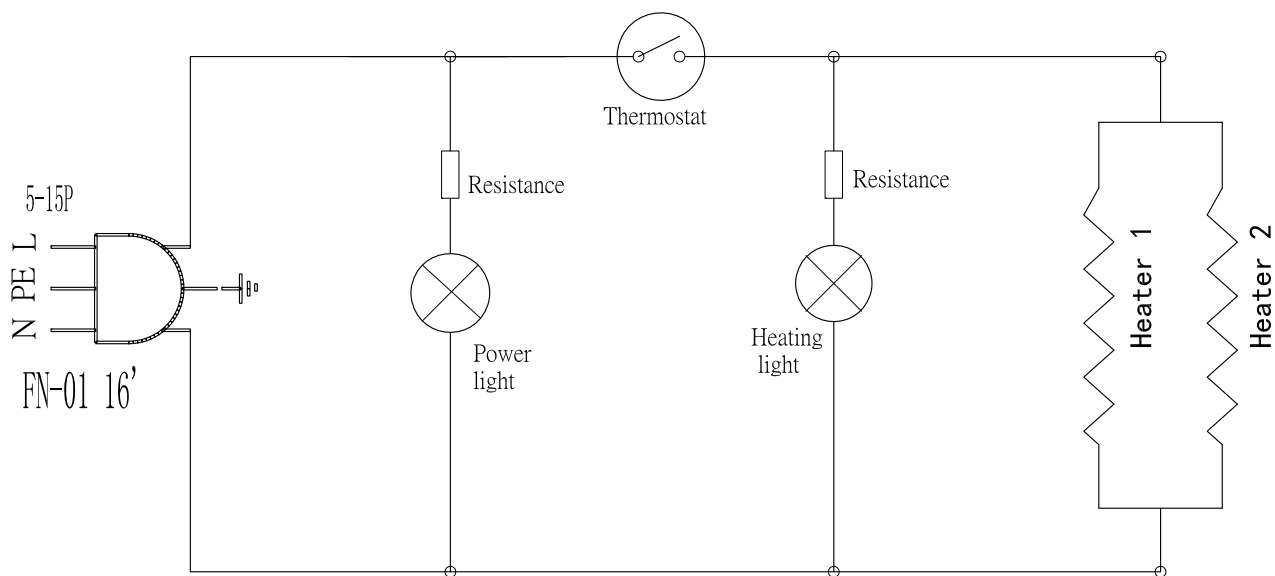

### EG24N

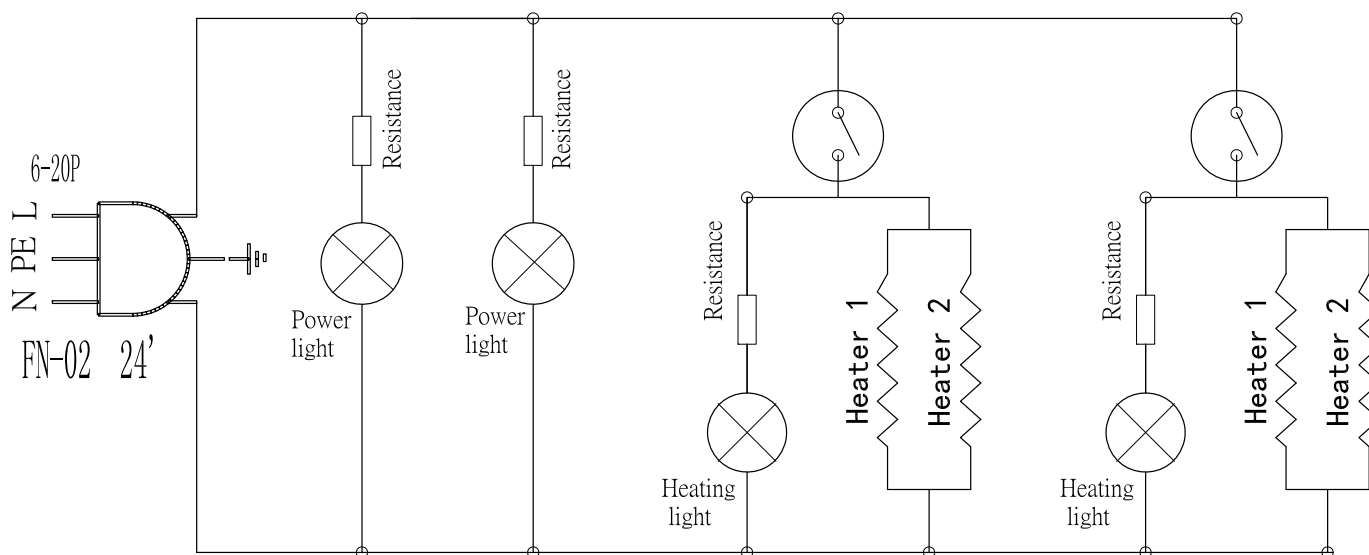

## EG30N

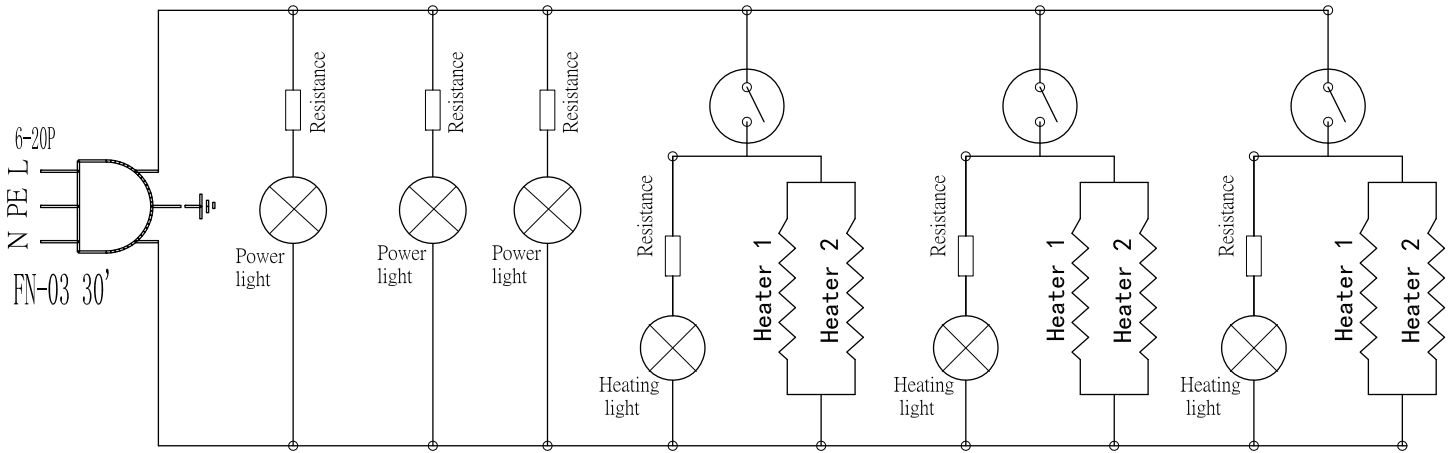

## EG36N

