



Service Manual – G4 Gemini Twin Coffee Brewer

Important Safeguards/Symbols

This equipment is designed for commercial use. Any servicing other than cleaning and routine maintenance should be performed by an authorized Wilbur Curtis Company Service Technician.

- DO NOT immerse the unit in water or any other liquid
- To reduce the risk of fire or electric shock, DO NOT open service panels. There are no user serviceable parts inside.
- Keep hands and other items away from hot areas of the unit during operation.
- Never clean with scouring powders or harsh chemicals.

Symbols:



WARNINGS – To help avoid personal injury



Important Notes/Cautions – from the factory



Sanitation Requirements

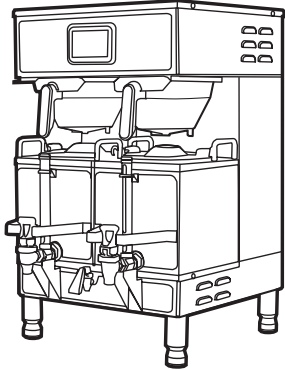

Model
• G4GEMT



CAUTION: Please use this setup procedure before attempting to use this brewer. Failure to follow the instructions can result in injury or the voiding of the warranty.



IMPORTANT: Equipment to be installed to comply with applicable governmental plumbing/electrical codes having jurisdiction.



CAUTION: DO NOT connect this brewer to hot water. The inlet valve is not rated for hot water.

This Curtis Generation 4 Unit is Factory Pre-Set and Ready to Go Right from the Box.

Following are the Factory Settings for your G4 Coffee Brewing System:

- Brew Temperature = 200°F
- Water Bypass = On for LARGE & MEDIUM Brew Only
- Brew Volume = Set to Vessel Requirement.

System Requirements:

- Water Source 20 – 90 PSI (Minimum Flow Rate of 1 GPM)
- Electrical: See attached schematic for standard model or visit www.wilburcurtis.com for your model.

SETUP STEPS

1. The unit should be level (left to right - front to back), on a secure surface.
2. Connect the water line to the water inlet fitting on the rear of the unit. Water volume flow to the machine should be consistent. Use tubing sized sufficiently to provide a minimum flow rate of one gallon per minute.



NOTE: A water filtration system must be used to help maintain trouble-free operation. In areas with extremely hard water, we highly recommend the use of a Curtis approved water filter. For our full line of filters, please log on to www.wilburcurtis.com. A water filtration system will greatly prolong the life of the unit and enhance the quality and taste of the product.



NSF International requires the following water connection:

1. A quick disconnect or additional coiled tubing (at least 2x the depth of the unit) is required so that the unit can be moved for cleaning.
2. This unit must be installed with adequate backflow protection to comply with applicable federal, state and local codes.
3. Water pipe connections and fixtures directly connected to a portable water supply shall be sized, installed and maintained in accordance with federal, state, and local codes.

3. Connect the unit to electrical outlet with appropriate amperage rating (see serial tag on machine).
4. Once power has been supplied to the unit, flip the toggle switch to the 'ON' position (located on the rear of the unit), the water tank will begin to fill. When the water level in the tank reaches the probe, the heating element(s) will turn on.
5. Water in the heating tank will require approximately a half hour before reaching operating temperature (factory setting of 200°F). Where applicable, turn on the Universal Control Module (UCM). When the unit reaches operating temperature, it will display "READY TO BREW".

ISO 9001:2008 REGISTERED

WILBUR CURTIS CO., INC.
6913 West Acco Street
Montebello, CA 90640-5403
For the latest information go to
www.wilburcurtis.com
Tel: 800-421-6150
Fax: 323-837-2410

For the latest specifications and information go to www.wilburcurtis.com
Technical Support: 1-800-995-0417 M-F 5:30am-4:00pm PT

Email: techsupport@wilburcurtis.com

QUICK START

Your Curtis G4/Gold Cup Series is Factory Pre-Set for Optimum Performance.

After connection to water and power; turn on the brewer at the rear toggle switch. You will hear a beep and the status lights will come on for a moment.

The screen will display MODEL NUMBER
CONTROL BD NUMBER. Next FILLING is displayed. Water will fill the tank (2-3 minutes depending on water flow rate).

When the proper level is reached HEATING will appear on the screen. It takes approximately 30 minutes to reach the set point temperature.

Control will display READY TO BREW when temperature reaches the set point. The unit is now ready to brew.

COFFEE BREWING INSTRUCTIONS

1. Brewer should be ON (Confirm at the rear toggle switch). The LCD screen should read Ready to Brew.
2. Place an empty satellite server on the warmer deck, under the brewcone and touch the warmer icon to Preheat the satellite.

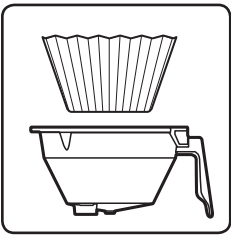

3. Place a clean filter into the brewcone.

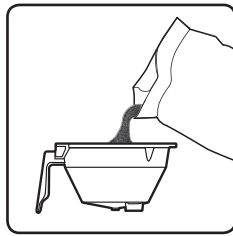

4. Fill brewcone with ground coffee.

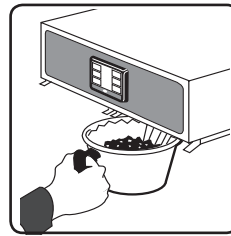

5. Transfer filled brewcone to brewer.

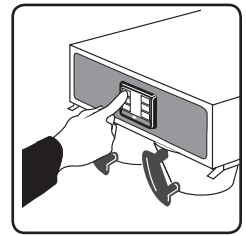

6. Touch desired brew button. Brewing will begin immediately.



WARNING TO AVOID SCALDING, Do not remove brewcone while brew light is flashing.

Touch Screen Control Module

The touch screen turns on when power is available to the controller. The screen will contain standard control feature such as symbols and buttons. Pressing these elements with your finger tip will activate the programming functions. The default screen, as well as some added control buttons are shown in the illustration below.

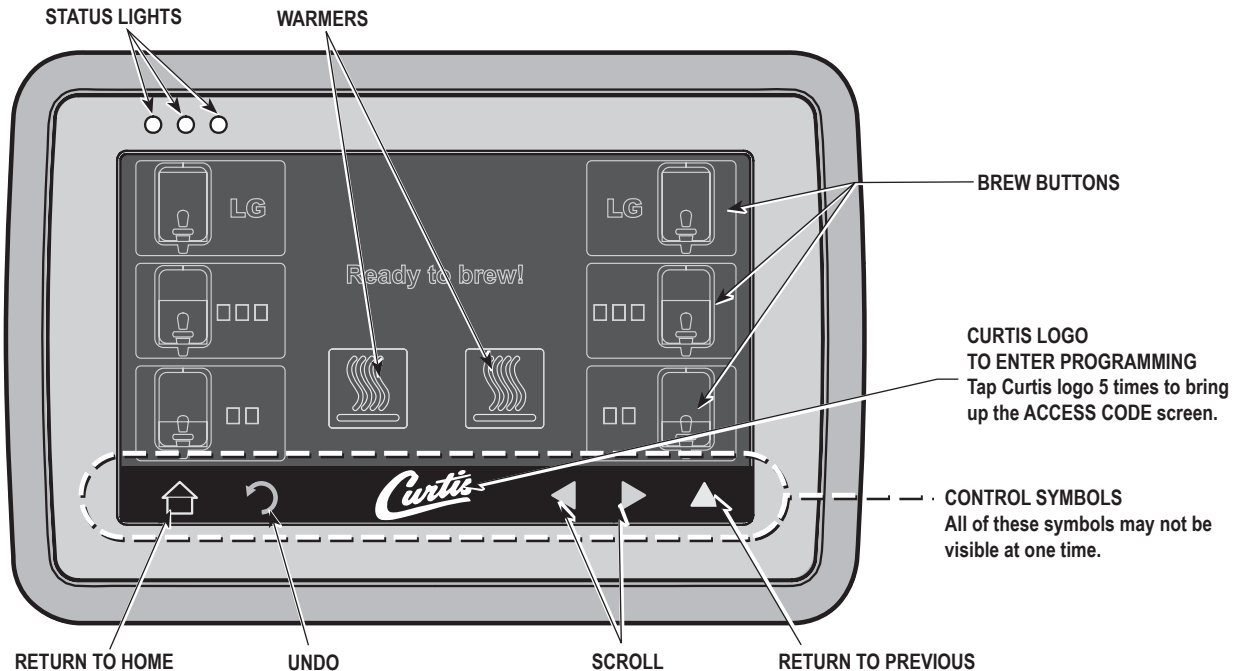

PROGRAMMING

ACCESS CODE
screen. Default is 1 2 3 4. Once the code is entered, press OK. The Main Menu screen will appear.

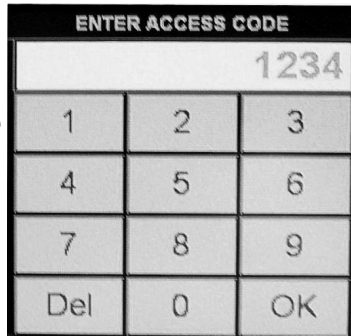

MAIN MENU screen contains five control icons: RECIPES, CONTROL SETTINGS, BREW SETTINGS, MODEL SELECT and EXIT.

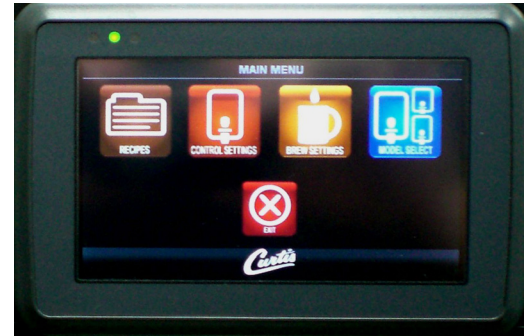

Menu Tree

This chart explains how to enter the program mode and menu selections available from the MAIN MENU.

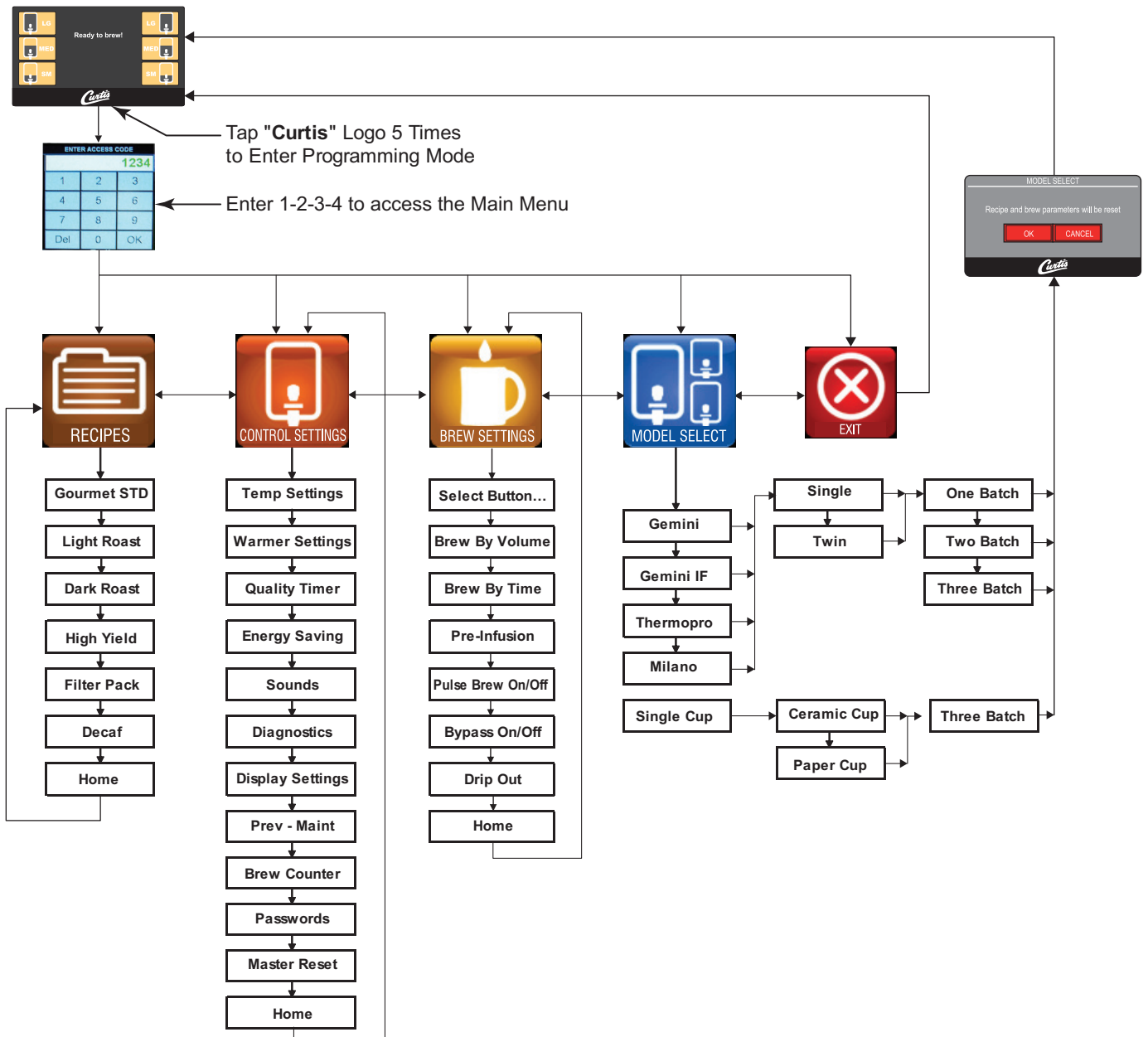

Menu Features

Recipes

FUNCTION TO SET	SETTING RANGE	FACTORY SET DEFAULT	NOTES / COMMENTS
Global Recipes	Gourmet STD, Light Roast, Dark Roast, High Yield, Filter Pack, Decaf, Home	Gourmet STD	

Control Settings

FUNCTION TO SET	SETTING RANGE	FACTORY SET DEFAULT	NOTES / COMMENTS
Temp Settings	170°F - 206°F , 2°F Increments	200°F	-
Warmer Settings	Disabled, 1 Hr - 12 Hr, 1 Hr Increments.	<Disabled on GEMTS/GEMSS>	Note: This function is only visible on Gemini Units.
	1 Hr - 12 Hr, 1 Hr Increments.	<10 Hr. on GEMTIF/GEMSIF>	
	<OFF>, <HIGH>, <MED.>, <LOW>	<MED.> During Brewing	
Quality Timer	OFF, 20min - 240min, 10 Minute Increments.	<OFF on GEMTS/GEMSS> <120min on GEMTIF/GEMSIF>	Audible alarm when time is expired. (Only shows available when a machine has Warmer Elements). (Also this function is visible when Gemini models are selected).
Energy Save Mode	Off	OFF	Off: Tank temperature maintained at 200°
	On		On: Tank temperature is not maintained.
	On-140°F		On-140°: Tank temperature maintained at 140F.
Sounds	Beeper On/Off	On	Turns Board sounds Off or On
	Voice Sounds On/Off	Off	Turns Speaker On or Off (If Applicable)
	Voice Volumes (0% - 100%, 5% Increments)	0%	Turns Speaker Volume Up or Down (If Applicable)
Diagnostics	-	Auto Test	This Function Runs A Diagnostic Test On All Systems In The Brewer. Brew Cones Must Be Inserted And Vessels Must Be Placed Under Brew Cones With Auto Test. Auto Test Must Be Limited To Only Two Cycles. Three Cycles Will Overflow The Tank.
Display Settings	Show Brew Time On/Off	On	Displays Brew Time
	Show Quality Timer On/Off	On	Displays Quality Timer
	Screen Saver On/Off	Off	Displays Screen Saver
	Display Name	Curtis	Displays Banner Name
Prev. Maint	Maintenance Interval	Off	Off, 1000 to 20000 Gallons, 1000 Increments
	Service Telephone Number	1-800-000-0000 x0000	-
Brew Counter	Resetable	Resetable	For maintenance purpose (Resetable)
Passwords	Resetable	1234	Not Resetable

Menu Features

Control Settings Continued

Master Reset	Reset	Are you sure? (Yes / No)	Select to Reset to Restore Factory Defaults
Home	-	-	Select to go to Home Page

Brew Settings

FUNCTION TO SET	SETTING RANGE	FACTORY SET DEFAULT	NOTES / COMMENTS
Brew by Volume	OFF, 30sec to 19Min.59sec.	LARGE BREW: 200oz ± 8oz using a Amber AFS Sprayhead	To Set: Press Brew to start / Press Brew to stop.
		MEDIUM BREW: 132oz ± 4oz using a Amber AFS Sprayhead	
		SMALL BREW: 64oz ± 4oz using a Amber AFS Sprayhead	
Brew by Time	0 to 19Min - 59sec, 1min-01secs increments	LARGE BREW: 5min 25secs using a Amber AFS Sprayhead	Note: These are the default times for a Amber AFS Sprayhead,
		MEDIUM BREW: 3min 32secs using a Amber AFS Sprayhead	
		SMALL BREW: 1min 52secs using a Amber AFS Sprayhead	
Pre-Infusion	Disabled	Disabled	OFF
	10 secs On/10 secs Off		
	20 secs On/20 secs Off		
	30 secs On/30 secs Off		
	40 secs On/40 secs Off		
	50 secs On/50 secs Off		
	60 secs On/60 secs Off		
Pulse Brew On/Off	OFF	C	OFF
	A		
	B		
	C		
	D		
	E		
By-Pass On/Off	Off, 5%-50%, in 5% increments	LARGE BREW: 35% using a Amber AFS Sprayhead MEDIUM BREW: 10% using a Amber AFS Sprayhead SMALL BREW: Off using a Amber AFS Sprayhead	Note: These are the default times for a Amber AFS Sprayhead
Drip-Out Mode	Off, 5 Seconds - 15min, 10 Second Increments	2 min	Reprogrammable
Home	-	-	Select to go to Home Page

System Fault Messages

WARNING MESSAGES - ALLOWS BREWING		
MESSAGE DISPLAY	WARNING DESCRIPTION	CAUSE
Component Failure Service Required 1-(800)-000-0000x	A Component has Failed	Current in one of the components is not within normal range.
Maintenance Required Service Required 1-(800)-000-0000x	Maintenance Required	Brew count "Gallons Since Reset" exceeds programmed Preventative Maintenance period
Lime Scale Warning Service Required 1-(800)-000-0000x	Scale Starting to Build Up Water Level Probe	Water level probe resistance above warning threshold (test value 23k Ohm)
Low Water Flow Warning Service Required 1-(800)-000-0000x	Low Water Flow	If the Inlet valve remains on longer than 40 Seconds (during the brew cycle only) and repeats TWICE during that brew cycle. It shall clear upon the next brew and if the same low flow exists again, it will re-appear.
ERROR MESSAGES - STOPS BREWING		
MESSAGE DISPLAY	ERROR DESCRIPTION	CAUSE
Water Level Error Service Required 1-(800)-000-0000x	Fill run error / Overflow	The fill solenoid has either run for more than 10 minutes on the initial tank fill or 1.5 minutes in normal operation
Sensor Error Service Required 1-(800)-000-0000x	Open Sensor	Break in the temperature thermistor circuit or short circuit.
Over Temp. Error Service Required 1-(800)-000-0000x	Excess Temperature	The sensor is reading that temperature in the heating tank has risen above 210°F, or sensor has shorted to ground.
Lime Scale Error Service Required 1-(800)-000-0000x	Probe	Water level probe resistance above error threshold (test value 180kOhm)
Internal Error 1 Service Required 1-(800)-000-0000x	UPM-UCM Communication	Break in the UPM-UCM Communication circuit.

Illustrated Parts Main View

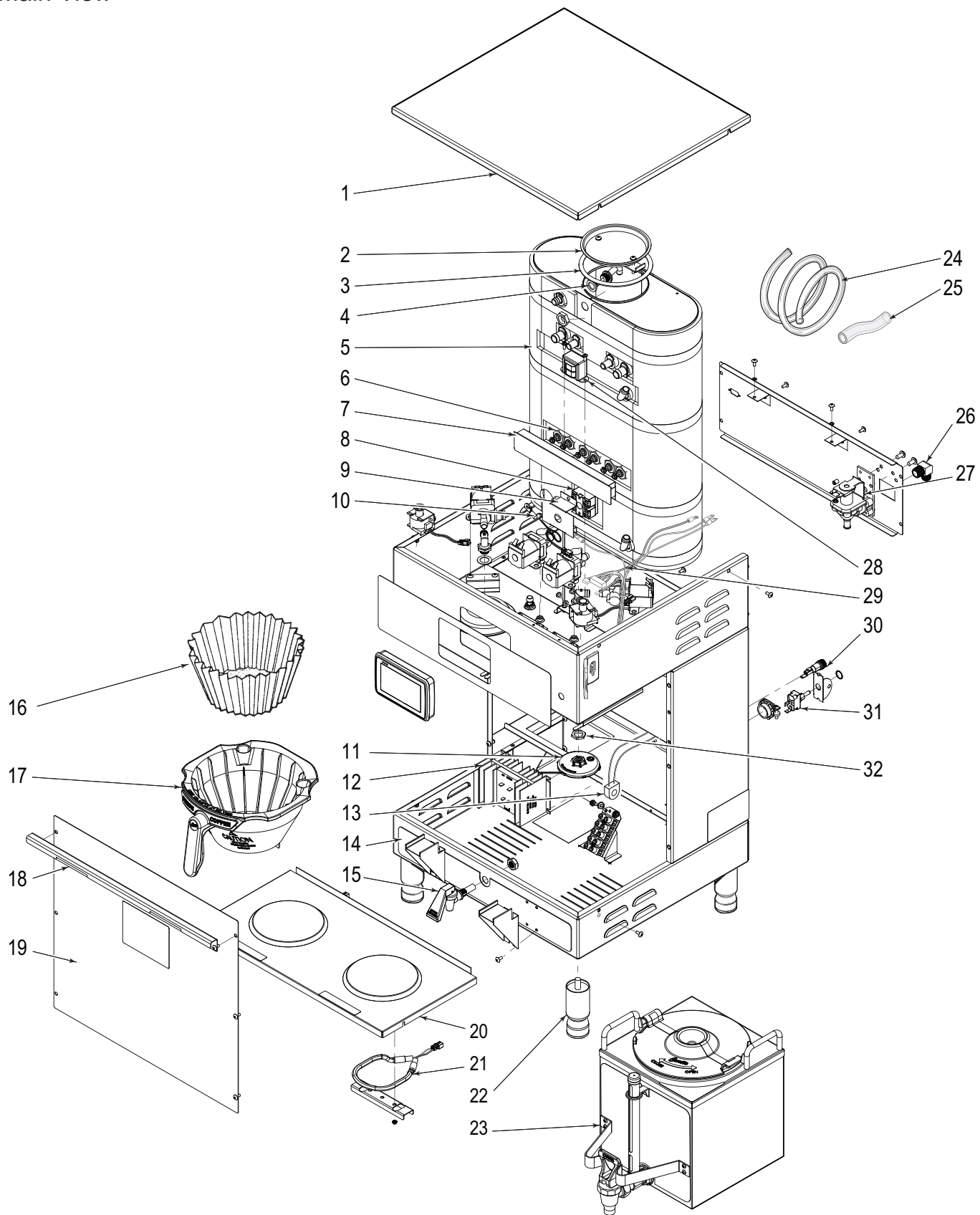

Illustrated Parts

Top Wrap

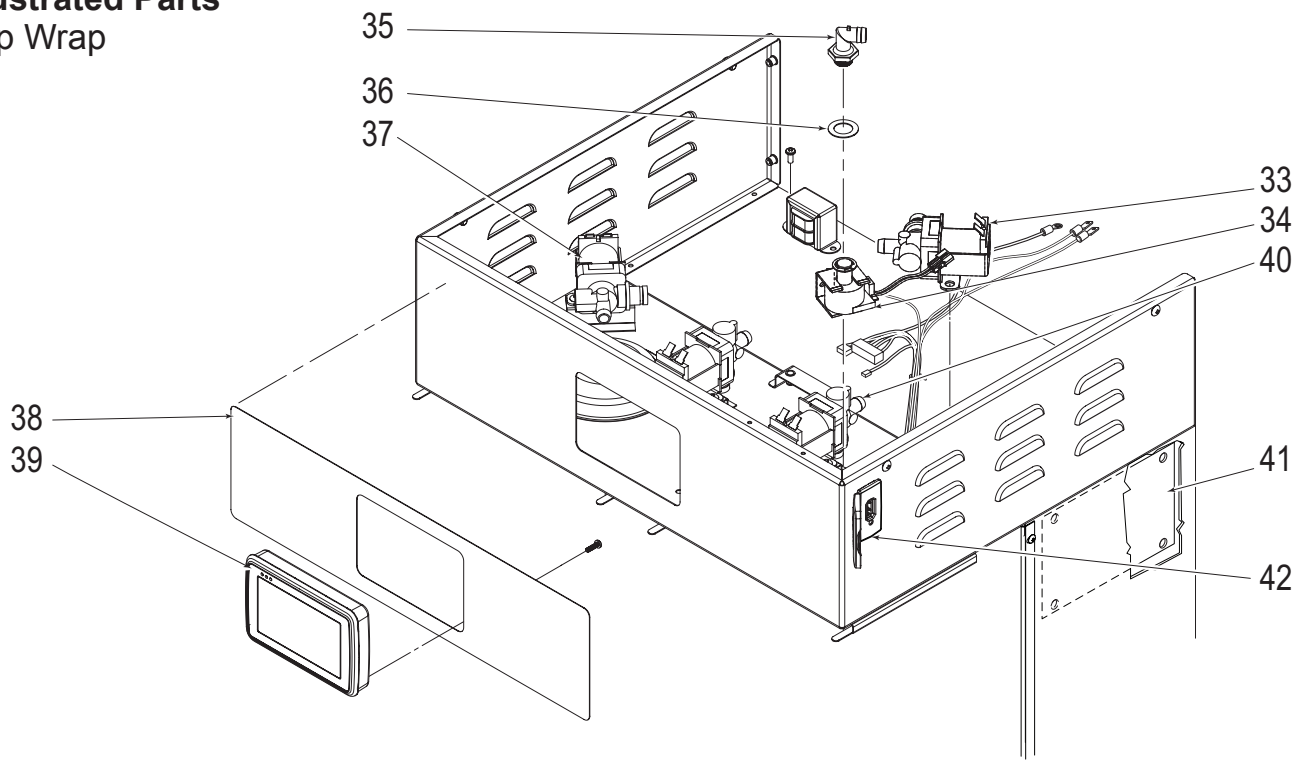

Rough-In Drawing

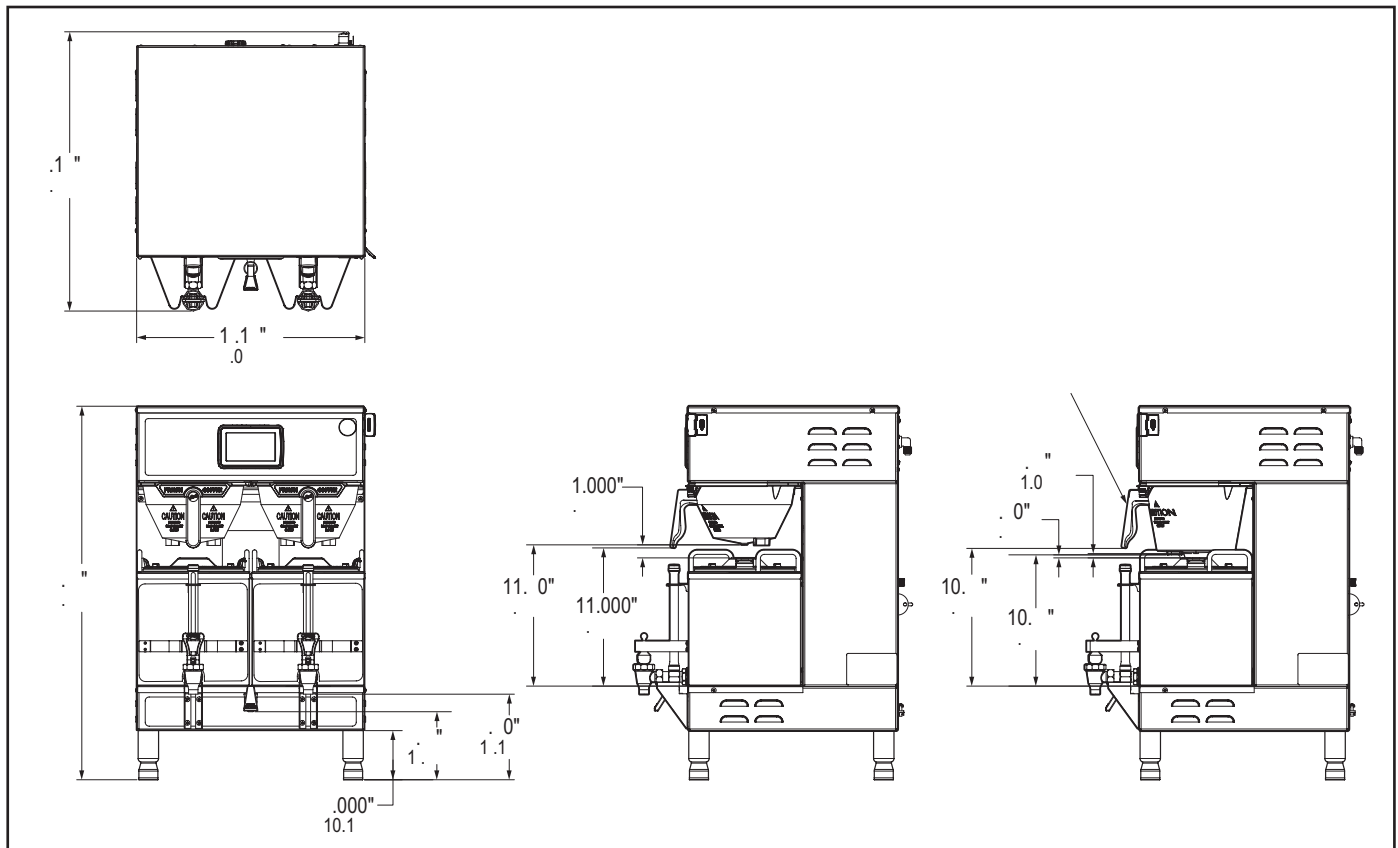

Parts List

ITEM NO.	PART NO.	DESCRIPTION
1	WC-5421-BLK	COVER, TOP - PAINTED BLACK TEXTURE PC
1A	WC-5421	COVER, TOP STAINLESS GEMTIF
2	WC-37008	KIT, TANK LID ROUND
3	WC-43067*	O-RING, 4-1/2 I.D. x Ø.285 C.S. SILICONE
4	WC-37406*	KIT, FAIL SAFE PROBE NON-METALLIC ROD
5	WC-62033	TANK COMPLETE, GEMTS WITH ULTEM FITTINGS
6	WC- 934-04*	KIT, HEATING ELEMENT 2.5KW 220V W/JAM NUT & SILICONE WASHERS
7	WC-4382*	GUARD, SHOCK - DOUBLE HEATING ELEMENTS
8	WC- 522*	THERMOSTAT, HI LIMIT HEATER DPST 277V-40A
9	WC-43055	GUARD, SHOCK RESET THERMOSTAT
10	WC-1438-101*	SENSOR, TEMPERATURE TANK
11	WC-29050*	SPRAYHEAD ASSY, AFS-AMBER
12	WC-8559*	RELAY, SOLID STATE 40A w/INTEGRATED HEATSINK
13	WC-14045-101	CURRENT SENSOR ASSY G4
14	WC-39745	LABEL, BOTTOM WRAP - GEMTIF
15	WC-1809	FAUCET, PS/HSP SERIES HOT WATER 1/2-20 UNF
16	GEM-6*	FILTER, 500PK GEM-12/230A
17	WC-37308	KIT, BREW CONE GEMINI NON-METAL with "FRESH COFFEE" LOGO
18	WC-37310	KIT, BREWCONE ALIGNMENT BRACKET STAINLESS
19	WC-61309	COVER, FRONT CENTER WRAP W/A STAINLESS GEMTIF
20	WC-61301	DECK, WARMER WELD ASSEMBLY GEMTIF
21	WC-37102*	KIT, WARMER ELEMENT
22	WC-3528	LEG, 4" ADJUSTABLE 3/8-16 THRD STYLIZED
23	GEM-3	SATELLITE SERVER, 1-1/2 GAL.
24	WC-5310*	TUBE, 5/16 ID x 1/8W SILICONE
25	WC-5350*	TUBE, SILICONE Ø1/2" ID x Ø3/4" OD x 1/8" WALL
26	WC-2402P	ELBOW, 3/8 NPT x 3/8 FLARE PLATED
27	WC- 847*	VALVE, INLET 2 GPM 120V-10W
28	WC- 589-101	TRANSFORMER, 120/230VAC - 24VAC 4.8VA w/LEADS & TERMINALS
29	WC-13450	HARNESS ASSY, COMPLETE TP2T10G4/GEMTS10G4/GEMTIF10G4
30	WC-1501	FUSE, HOLDER ASSY w/5A FUSE
31	WC- 102 *	SWITCH, TOGGLE SPST 15A 125Vac RESISTIVE
32	WC-4212-02	NUT, 5/8-18 JAM PLASTIC-ULTEM
33	WC-37121	KIT, DUMP VALVE LEFT
34	WC- 442 *	SOLENOID, LOCK BREW CONE RIGHT 120VAC
35	WC-2977-101	FITTING, SPRAYHEAD ULTEM
36	WC-43089*	GASKET, 1.00"OD x .625" I.D. x .030" THK RED SILICONE 40 SHORE
37	WC-37122*	KIT, DUMP VALVE RIGHT
38	WC-39812	LABEL, OUTER TOUCHSCREEN GEMTSG4 CURTIS LOGO
39	WC-10000*	CONTROL MODULE, TOUCH SCREEN G4
40	WC- 844-101*	VALVE, BYPASS 120V-14W NON ADJUSTABLE WITH RESTRICTOR (WC-2945)
41	WC-10001*	UNIVERSAL POWER MODULE - G4
42	WC-10008	UNIVERSAL HOST ADAPTER (USB)

* RECOMMENDED PARTS TO STOCK

Electrical Schematic

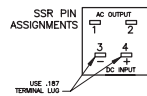
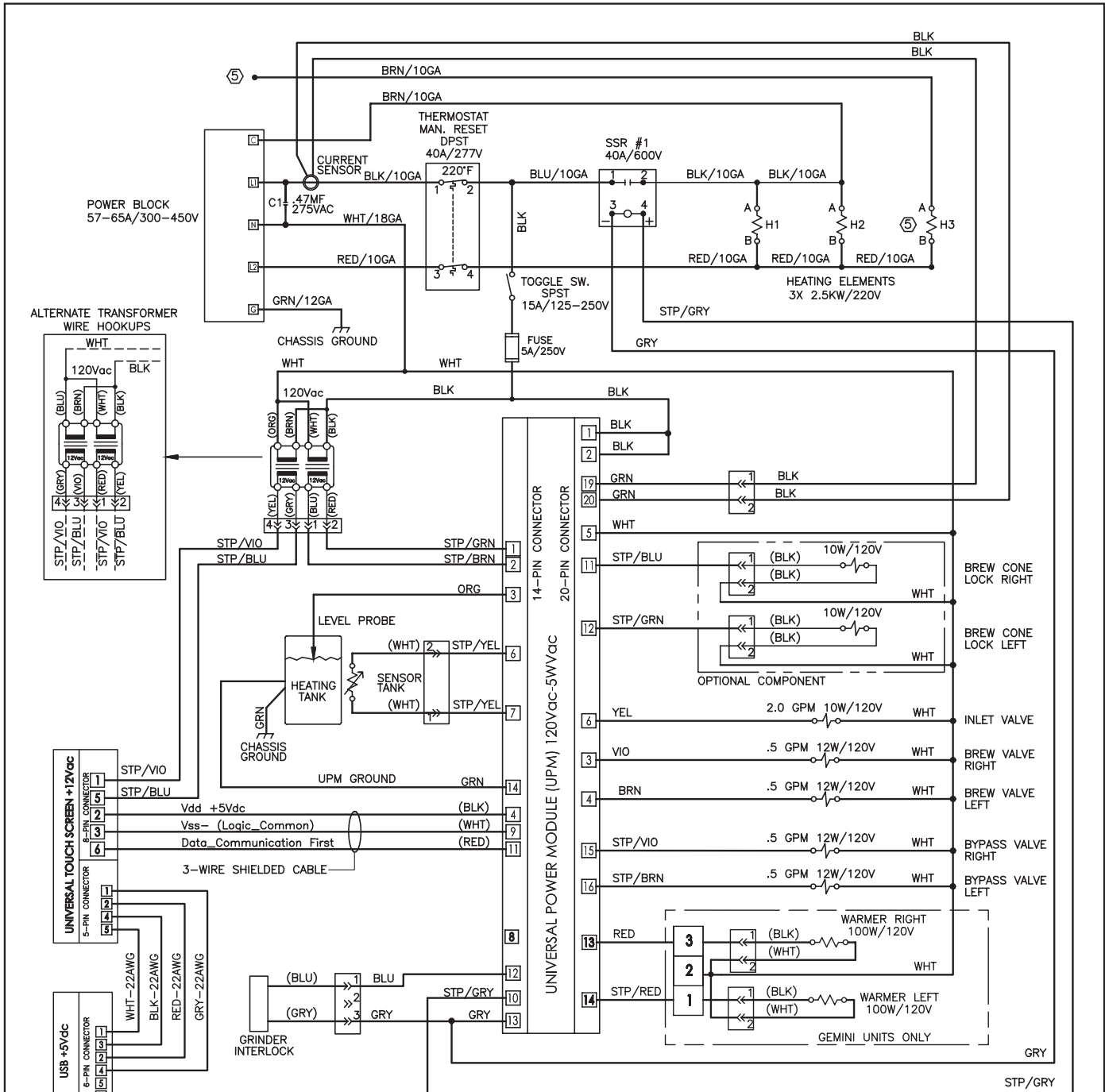

ELECTRICAL RATING TABLE

MACHINE	HEATING ELEMENTS			WARMERS		TOTAL POWER (WATTS)	TOTAL CURRENT (AMPERES)
	H1	H2	H3	LEFT	RIGHT		
GEMTS10 & GEMTN10	•	•	•	•	•	5200	23.6
GEMTS10 & GEMTN10 W/ H3	•	•	•	•	•	7600	34.5
TP2T10/TPC2T10/TP1T10/TP1TT10	•	•	•	•	•	5100	23.0
TP2T10/TPC2T10/TP1T10/TP1TT10 W/ H3	•	•	•	•	•	7600	34.5

- ⑤ H1 AND H2 CONNECTION ONLY: REMOVE & CAP BRN WIRE END FROM H3
 H1, H2 AND H3 CONNECTION: REMOVE CAP & CONNECT BRN WIRE FROM H3 TO C (COMMON) ON POWER BLOCK.
 ④ USE THIS DIAGRAM FOR ALL OTHER MODELS WITH ADDED PREFIX LETTERS AND/OR SUFFIX NUMBERS ON THEIR PART NUMBERS HAVING THE SAME ELECTRICAL RATINGS.

3. LOCATE MATED CONNECTORS AWAY FROM HEAT.
 2. INSTALL GROUND LUG OVER THE SENSOR ON TANK SENSOR STUD.
 1. ALL WIRES SHALL BE 18AWG UNLESS NOTED.
 NOTES: UNLESS OTHERWISE SPECIFIED

VOLTAGE:	220V
WATTAGE:	SEE TABLE
AMPERAGE:	SEE TABLE
HERTZ:	50/60 HZ
WIRES:	3W + G
PHASE:	1 PHASE

④ LADDER DIAGRAM
 LD-GTPTG4-10.0000 C

Cleaning the Coffee Brewer

Regular cleaning and preventive maintenance is essential in keeping your coffee brewer looking and working like new.



CAUTION – Do not use cleansers, bleach liquids, powders or any other substance containing chlorine. These products promote corrosion and will pit the stainless steel. USE OF THESE PRODUCTS WILL VOID THE WARRANTY.

1. Wipe exterior surfaces with a moist cloth, removing spills and debris.
2. Slide the brewcone out and clean it. Clean the sprayhead area with a moist clean cloth.
3. Rinse and dry the brewcone.
4. Drain drip tray of coffee. Wash out the drip tray. Dry the tray.
5. Rub a stainless steel polish on the outside surfaces to protect the brewer.

Cleaning the Satellite Server

To clean the Satellite components, prepare a mild solution of detergent and warm water..

1. Remove lid from Satellite. Clean the lid at the funnel area with a spiral brush and detergent solution.
2. Rinse the lid, removing all traces of cleaning solution.
3. Unscrew the handle/bonnet assembly and remove it from the dispensing faucet.
4. Pull the silicone seat cup from faucet stem and inspect it for wear, cracks, or hardening. Replace the seat cup if necessary.
5. Clean all parts. Thoroughly rinse with clear warm water.
6. Dry and assemble the handle/bonnet parts. Hand-tighten the assembly onto the faucet.
7. Remove the gauge glass tube by unscrewing the gauge glass cap.
8. Clean the gauge glass tube and the two washers with a gauge brush and detergent solution. Rinse with clear water. Dry the parts and assemble them onto the Satellite.

DO NOT immerse the Satellite in water or any other liquid.

9. Clean inside of the Satellite. Remove coffee residue with the detergent solution.
10. Thoroughly rinse out the Satellite with clear warm water.

Product Warranty Information

The Wilbur Curtis Company certifies that its products are free from defects in material and workmanship under normal use. The following limited warranties and conditions apply:

- 3 Years, Parts and Labor, from Original Date of Purchase on digital control boards.
- 2 Years, Parts, from Original Date of Purchase on all other electrical components, fittings and tubing.
- 1 Year, Labor, from Original Date of Purchase on all electrical components, fittings and tubing.

Additionally, the Wilbur Curtis Company warrants its Grinding Burrs for Forty (40) months from date of purchase or 40,000 pounds of coffee, whichever comes first. Stainless Steel components are warranted for two (2) years from date of purchase against leaking or pitting and replacement parts are warranted for ninety (90) days from date of purchase or for the remainder of the limited warranty period of the equipment in which the component is installed.

All in-warranty service calls must have prior authorization. For Authorization, call the Technical Support Department at 1-800-995-0417. Effective date of this policy is April 1, 2003.

Additional conditions may apply. Go to www.wilburcurtis.com to view the full product warranty information.

CONDITIONS & EXCEPTIONS

The warranty covers original equipment at time of purchase only. The Wilbur Curtis Company, Inc., assumes no responsibility for substitute replacement parts installed on Curtis equipment that have not been purchased from the Wilbur Curtis Company, Inc. The Wilbur Curtis Company will not accept any responsibility if the following conditions are not met. The warranty does not cover and is void under the following circumstances:

- 1) **Improper operation of equipment:** *The equipment must be used for its designed and intended purpose and function.*
- 2) **Improper installation of equipment:** *This equipment must be installed by a professional technician and must comply with all local electrical, mechanical and plumbing codes.*
- 3) **Improper voltage:** *Equipment must be installed at the voltage stated on the serial plate supplied with this equipment.*
- 4) **Improper water supply:** *This includes, but is not limited to, excessive or low water pressure, and inadequate or fluctuating water flow rate.*
- 5) **Adjustments and cleaning:** *The resetting of safety thermostats and circuit breakers, programming and temperature adjustments are the responsibility of the equipment owner. The owner is responsible for proper cleaning and regular maintenance of this equipment.*
- 6) **Damaged in transit:** *Equipment damaged in transit is the responsibility of the freight company and a claim should be made with the carrier.*
- 7) **Abuse or neglect (including failure to periodically clean or remove lime accumulations):** *Manufacturer is not responsible for variation in equipment operation due to excessive lime or local water conditions. The equipment must be maintained according to the manufacturer's recommendations.*
- 8) **Replacement of items subject to normal use and wear:** *This shall include, but is not limited to, light bulbs, shear disks, "O" rings, gaskets, silicone tube, canister assemblies, whipper chambers and plates, mixing bowls, agitation assemblies and whipper propellers.*
- 9) **Repairs and/or Replacements** *are subject to our decision that the workmanship or parts were faulty and the defects showed up under normal use. All labor shall be performed during regular working hours. Overtime charges are the responsibility of the owner. Charges incurred by delays, waiting time, or operating restrictions that hinder the service technician's ability to perform service is the responsibility of the owner of the equipment. This includes institutional and correctional facilities. The Wilbur Curtis Company will allow up to 100 miles, round trip, per in-warranty service call.*

RETURN MERCHANDISE AUTHORIZATION: *All claims under this warranty must be submitted to the Wilbur Curtis Company Technical Support Department prior to performing any repair work or return of this equipment to the factory. All returned equipment must be repackaged properly in the original carton. No units will be accepted if they are damaged in transit due to improper packaging. **NO UNITS OR PARTS WILL BE ACCEPTED WITHOUT A RETURN MERCHANDISE AUTHORIZATION (RMA). RMA NUMBER MUST BE MARKED ON THE CARTON OR SHIPPING LABEL.** All in-warranty service calls must be performed by an authorized service agent. Call the Wilbur Curtis Technical Support Department to find an agent near you.*

7/6/11@10.3 . EDR 7842



WILBUR CURTIS CO., INC.

6913 Acco St., Montebello, CA 90640-5403 USA

Phone: 800/421-6150 ♦ Fax: 323-837-2410

♦ Technical Support Phone: 800/995-0417 (M-F 5:30A - 4:00P PST)

♦ Web Site: www.wilburcurtis.com

♦ E-Mail: techsupport@wilburcurtis.com

7/11 . F-3804 rev NC