



**builderSchwank**  
**S100 - S100U**  
**Models**

**&**

**builder**  
**ITB - ITBU**  
**Models**

LOW INTENSITY TUBE TYPE INFRARED HEATERS

# INSTALLATION / OWNER'S MANUAL



**WARNING** Improper installation, adjustment, alteration, service or maintenance can cause property damage, injury or death. Read the installation and operating and maintenance instructions thoroughly before installing or servicing this equipment.

**SAFETY ALERT:**



This heater must be installed and serviced only by a trained gas service technician. Failure to comply could result in personal injury, death, fire and/or property damage.

Do not store or use gasoline or other flammable vapours and liquids in the vicinity of this or any other gas fired appliance.



**IF YOU SMELL GAS:**

- Extinguish any open flame
- Do not attempt to light this or any other appliance
- Don't touch any electrical switch, or telephone
- Immediately call your gas supplier from a neighbor's phone
- Follow any and all instruction from your gas supplier
- If your gas supplier is not available, call the fire department



**FIELD CONVERTIBILITY:**  
 This appliance is field convertible to Propane.

**Keep this manual in a secure place .**  
*Record for future reference:*

Model #: \_\_\_\_\_

Serial #: \_\_\_\_\_

*(located on heater rating label)*

**GAS-FIRED**



S100-F / ITB-F I&O Manual  
 IM101230  
 RD: NOV 2021  
 RL: 15A

**NOTICE:**

*This manual is current for this product. Occasional revision of the product Certification Standard may require changes to the product and/or this manual.*

*This publication, or parts thereof, may not be reproduced in any form, without prior written consent from The Manufacturer. Unauthorized use or distribution of this publication is strictly prohibited.*

**Schwank**

Schwank and InfraSave brands

5285 Bradco Boulevard

Mississauga, Ontario, L4W 2A6

PO Box 988, 2 Schwank Way

Waynesboro, Georgia 30830

**Customer & Technical Services**

Phone: 877-446-3727 OR 706-554-6191

Fax: 866-361-0523







e-mail: [csr@schwankgroup.com](mailto:csr@schwankgroup.com)

**[www.schwankgroup.com](http://www.schwankgroup.com)**

**[www.infrasave.com](http://www.infrasave.com)**

# S100 - S100U and ITB - ITBU SERIES GAS FIRED INFRARED LOW INTENSITY TUBE TYPE

## TABLE OF CONTENTS

TOPIC	..... PAGE	TOPIC	.....PAGE
<b><u>INSTALLATION</u></b>			
<b><u>IMPORTANT INFORMATION - READ FIRST</u></b>			
 APPLICATION .....	4	COMBINED SYSTEM LENGTH .....	26
 HEATER EXPANSION .....	5, 31	HEATER EXPANSION / VENT CONFIGURATION .....	27
 GAS CONNECTION .....	5, 31	VERTICAL VENT THROUGH ROOF .....	28
 VENTING .....	5, 26	HORIZONTAL VENT THROUGH WQALL .....	29
 START UP 'SMOKE' .....	5	12. COMBUSTION AIR DUCT .....	31
THERMOSTAT SETTING / COMFORT .....	5	13. GAS SUPPLY .....	32
TUBE 'GLOW' .....	6	HEATER EXPANSION .....	33
 CLEARANCE TO COMBUSTIBLES .....	6	FLEXIBLE GAS CONNECTION .....	34
Clearances Figure & Table .....	7	14. ELECTRICAL AND THERMOSTAT .....	35
STACKING HEIGHT SIGN .....	8	15. HIGH ALTITUDE INSTALLATION.....	35
1. LABOR REQUIREMENTS .....	9	16. LIGHTING INSTRUCTIONS .....	35
2. INSTALLATION IN AIRCRAFT HANGARS .....	9	17. RECOMMENDED MAINTENANCE .....	35
3. INSTALLATION: COMMERCIAL GARAGES .....	9	18. WIRING DIAGRAM: FENWAL DSI 24V or 120V THERMOSTAT .....	36
4. INSTALLATIONS OTHER THAN SPACE HEATING .....	9	18A. WIRING DIAGRAM: MULTIPLE HEATERS PER THERMOSTAT .....	37
5. PRE-INSTALLATION SURVEY .....	10	19. FENWAL SEQUENCE OF OPERATION .....	39
6. MOUNTING CLEARANCES .....	11	SPARK IGNITER SET UP .....	40
SERVICE CLEARANCE .....	11	FENWAL DSI SERVICE CHECK .....	40
HEATER PLACEMENT GUIDELINES .....	12	20. TROUBLESHOOTING GUIDE: HEATER.....	41
7. SYSTEMS WITH 90° & 180° ELBOWS.....	12	21. START- UP / COMMISSIONING SHEET .....	43
ELBOW KIT DIMENSIONS .....	13	<b><u>PRODUCT DIMENSIONS &amp; DATA</u></b>	
8. SUSPENDING THE SYSTEM .....	14	22. BURNER / TUBE KIT ASSEMBLY CHART STRAIGHT TUBE SYSTEM .....	45
9. BURNER & TUBE INSTALLATION		23. 'U' TUBE SYSTEM .....	46
STRAIGHT TUBE SYSTEM .....	15	24. MODEL INPUTS, DIMENSIONS, WEIGHTS ..47	
'U' TUBE SYSTEM .....	17	INSTALLATION DIMENSIONS .....	48
SPECIAL COUPLING - 100, 175 & 200 Mbh..20		25. TURBULATORS - Straight & U-Tube .....	49
9.4 SEISMIC RESTRAINT .....	22	TURBULATORS - ILLUSTRATED .....	50
9.5 HIGH WIND RESTRAINT.....	22	26. GAS CONVERSION KITS.....	51
9.6 SEISMIC RESTRAINT 'U'-TUBE .....	23	26. HIGH ALTITUDE & ORIFICE CHART .....	52 - 53
10. REFLECTOR INSTALLATION.....	24	27. OPTIONAL ACCESSORIES.....	54 - 56
11. FLUE VENTING .....	25	28. BURNER PARTS LIST .....	57 - 59
		29. TUBE SYSTEM PARTS LIST .....	60-61
		WARRANTY STATEMENT .....	BACK PAGE



## WARNING

Improper installation, adjustment, alteration, service or maintenance can cause property damage, injury or death. Read and

understand this installation and operation manual thoroughly prior to assembly, installation, operation or service to this appliance.



This heater must be installed and serviced only by a trained gas service technician.



Do not store or use gasoline or other flammable vapours and liquids in the vicinity of this or any other gas fired appliance.

Failure to comply could result in personal injury, death, fire and/or property damage.



Do not store or use gasoline or other flammable vapours and liquids in the vicinity of this or any other gas fired appliance.

This appliance may have sharp edges and corners. Wear protective clothing such as gloves and protective eye wear when servicing this or any other appliance.

### California Proposition 65:



**WARNING:** This product can expose you to chemicals including carbon monoxide, which is known to the State of California to cause birth defects or other reproductive harm. For more information, go to [www.P65Warnings.ca.gov](http://www.P65Warnings.ca.gov)

## APPLICATION

A gas-fired radiant tube heater may be installed for heating of commercial / industrial non-residential spaces. It is beyond the scope of these instructions to consider all conditions that may be encountered. Installation must conform with all local building codes or, in the absence of local codes, with the National Fuel Gas Code, ANSI Z223.1/NFPA 54 in the U.S.A. or the Natural Gas and Propane Installation Code, CSA B149.1 in Canada. The latest edition Electrical Code ANSI/NFPA N0 70 in the U.S.A. and PART 1 CSA C22.1 in Canada must also be observed.

Installation of a gas fired tube heater must conform to all heating installation design procedures including clearance to combustibles, connection to the gas and electrical supplies, and ventilation.

This heater is not for installation in a Class 1 or Class 2 explosive environment, nor a residence. If installation of this equipment is in question, consult with local authorities having jurisdiction (Fire Marshall, labor department, insurance underwriter, or others).

Revisions to codes and/or standards, may require revision to equipment and installation procedures. In case of discrepancy, the latest codes, standards, and installation manual will take priority over prior releases.

**Models S100 and ITB** may be installed for heating of commercial / industrial non-residential **indoor spaces**.

### MODELS AVAILABLE FOR OTHER APPLICATIONS:

**Models SPW-JZ and IWP** have a powder coated water resistant burner enclosure and may be installed for heating of commercial / industrial non-residential **outdoor spaces and wet indoor environments**.

**Models STW-JZ and IW** have a stainless steel water resistant burner enclosure and may be installed for heating of commercial / industrial non-residential **outdoor spaces and harsh wet indoor environments**.



## WARNING

### Heater Expansion



It is a normal condition that during heat-up and cool-down a tube heater will expand and contract. Allowances for heater expansion must be made in the gas connection, venting and combustion air ducting. Improper installation, alteration, or adjustment can result in property damage, injury or death. **Refer to Section 13**



## WARNING

### Gas Connection



Improper installation, connection, or adjustment can result in property damage, toxic gases, asphyxiation, injury or death. Using an approved flexible gas connector in the USA or Type 1 hose connector in Canada, the gas supply to the heater must be connected and tested in accordance with all local, state, provincial, and national codes (ANSI Z223.1/NFPA 54 in USA; B149.1 in Canada) and as indicated in this manual. **Refer to Section 13**



## WARNING

### Venting



Inadequate venting of a heater may result in asphyxiation, carbon monoxide poisoning, injury or death. This heater may be directly or indirectly vented from the space. Venting must be in accordance with all local, state, provincial, and national codes (ANSI Z223.1/NFPA 54 in USA; B149.1 in Canada) and as indicated in this manual.

**Refer to Sections 11 & 12**



## WARNING

### Start-Up 'SMOKE' Condition

During start up, the heating of material coatings used in the production process of tubes and reflectors will create smoke during the initial period of operation. This condition is normal and temporary .

Ensure that there is sufficient ventilation to adequately clear any smoke from the space.

Notify site and safety personnel to ensure that alarm systems are not unduly activated.



## IMPORTANT

### THERMOSTAT SETTING FOR COMFORT

Infrared radiant (IR) heating system provide comfort with the effect of radiant heat and ambient air heat.

If your IR system is controlled with a thermostat (TruTemp or ThermoControl Plus) that senses radiant heat, then set the thermostat to the desired comfort temperature (ie: 65°; 68°; 20°C).

If your IR system is controlled with a standard 24V or 120V thermostat that senses only air temperature, then start with a thermostat setting that is 5° to 7°F (3° to 5°C) lower than the desired comfort temperature. Some trial and error setting may be required to 'fine tune' the comfort temperature that best suits your site and provides most economical operation.



## WARNING

### Tube “GLOW”

It is a normal condition that the combustion tube (1st tube) can appear to “glow red”. For inputs up to 150,000 Btuh, the top surface of the tube can appear red where heat is trapped between the reflector and the tube. The stainless steel tube used for inputs 175,000 and greater can appear to entirely glow red. The tube material is designed into the heater because it can withstand the high temperature of combustion, and the “red glow” is a normal occurrence.



## WARNING

### Clearance to combustibles

Location of flammable or explosive objects, liquids or vapors close to the heater may cause fire or explosion and result in property damage, injury or death. Do not use, store or locate flammable or explosive objects, liquids or vapors in proximity of the heater.



**The clearance to combustible material represents the minimum distance that must be maintained between the outer heater surface and a nearby surface. The stated clearance to combustibles represents a surface temperature of 90F° (50C°) above room temperature. It is the installer’s responsibility to ensure that building materials with a low heat tolerance which may degrade at lower temperatures are protected to prevent degradation. Examples of low heat tolerance materials include vinyl siding, fabrics, some plastics, filmy materials, etc.**

In locations used for the storage of combustible materials, signs must be posted to specify the maximum permissible stacking height to maintain the required clearances from the heater to the combustibles. Such signs must either be posted adjacent to the heater thermostats or in the absence of such thermostats in a conspicuous location. In addition to stored or stationary material, consideration must also be given to moveable objects such as cranes, vehicles, and overhead doors, and structural objects such as sprinkler heads, electrical and gas lines, and electrical fixtures.

It is beyond the scope of these instructions to consider all conditions that may be encountered. Consult local authorities such as the Fire Marshall, insurance carrier, or safety authorities if you are uncertain as to the safety or applicability of the proposed installation.

**Refer to Figure 1 and Table 1 for the certified clearances to combustibles for the appropriate model input/size.**

**FIGURE 1 MINIMUM CLEARANCES TO COMBUSTIBLES\*** - refer to Table 1 for values

**NOTE:** A 'PEEL & STICK' SIGN IS SUPPLIED: USE AN INDELIBLE MARKER TO ENTER VALUES 'H', 'S', 'F', & 'B' ON .  
 POST THE SIGN ADJACENT TO THE HEATER THERMOSTAT OR IN A PROMINENT LOCATION. See next page for details.

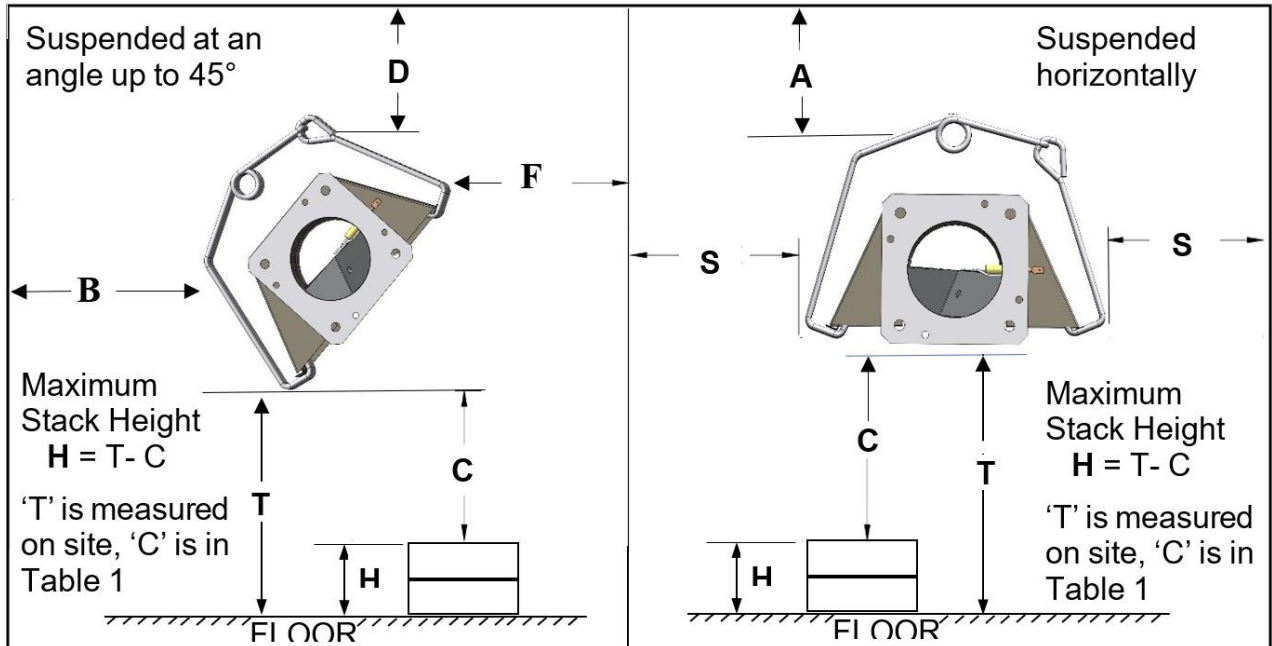

**TABLE 1 MINIMUM CLEARANCES TO COMBUSTIBLES\***

MODEL BOTH "STRAIGHT" & "U-TUBE"	SUSPENDED AT AN ANGLE UP TO 45 DEGREES				SUSPENDED HORIZONTALLY		
	D inches	B inches	F inches	C inches	A inches	S inches	C inches
S100(U)/ITB(U) 200	13	6	74	70	14	44	76
S100(U)/ITB(U) 175	12	6	72	68	13	42	74
S100(U)/ITB(U) 155	10	4	50	64	11	34	70
S100(U)/ITB(U) 130	10	3	45	60	10	32	65
S100(U)/ITB(U) 110	9	3	36	54	9	30	60
S100(U)/ITB(U) 80	7	2	31	38	7	24	42
S100(U)/ITB(U) 60	7	2	25	34	7	20	34
S100/ITB 45	7	2	29	32	7	16	32
S100 /ITB 100*	10	4	57	68	11	32	68

\*NOTE: Clearances are measured from the reflector.

S100 /ITB 100 is only available in 20ft therefore requires a higher minimum clearance.

The clearance to combustible materials represents the minimum distance that must be maintained between the heater and a nearby surface. **The stated clearance to combustibles represents a surface temperature of 90F° (50C°) above room temperature.**

**It is the installer’s responsibility to ensure that building materials with a low heat tolerance which may degrade at lower temperatures are protected to prevent degradation.**

**VENT END CLEARANCE:** Clearances from the vent pipe are determined by local or national installation codes, but must not be less than 6 inches.

For ‘unvented’ installation, a minimum distance of 48 inches is required from the end of heater to a combustible surface.



**WARNING**

**In locations used for the storage of combustible materials: Signs must be posted** specifying the *maximum permissible stacking height* to maintain the required clearances from the heater to the combustibles.

The signs must be posted either adjacent to the IR heating system thermostats or in the absence of such thermostats, in a conspicuous place.

For your convenience a “peel and stick” sign is provided with this heater. Use a permanent marker to record the required dimensions on the sign for the pertinent heater model.

To calculate the value ‘H’: ( $H = T - C$ )

- Measure the on site distance between bottom of the heater and the floor = ‘T’ inches (cm).
- Refer to Table 1 to get the value ‘C’ that corresponds to the model you are installing
- Subtract the clearance below the heater ‘C’ from ‘T’ to get value ‘H’.
- Enter this value ‘H’ on the sign.

Refer to the information for the heater model being installed in Figure 1 and Table 1 to get the values for dimensions ‘S’, ‘F’ and ‘B’.

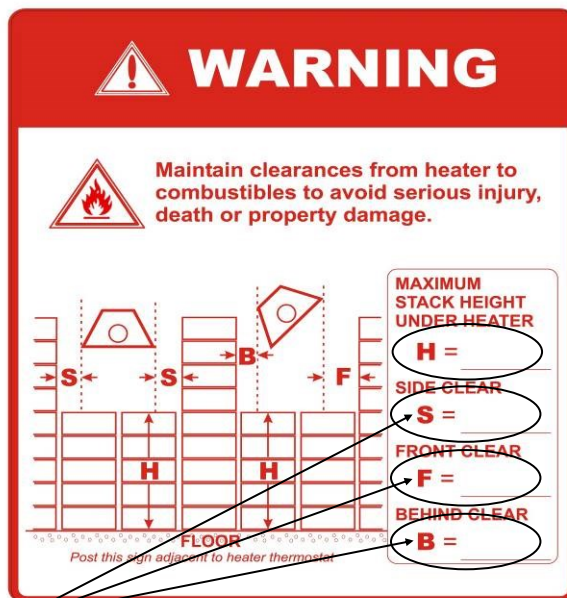

Post this sign as instructed above.



## 1. LABOR REQUIREMENTS

Two persons are required to safely install this equipment. Wear gloves and other required safety protection.

## 2. INSTALLATION IN COMMERCIAL AIRCRAFT HANGARS

Low intensity radiant tube heaters are suitable for use in aircraft hangars when installed in accordance with the latest edition of the Standard for *Aircraft Hangars*, ANSI/NFPA No 409 in the USA, or the Canadian *Natural Gas and Propane Installation Code*, B149.1.

- A. A minimum clearance of 10 ft above either the highest fuel storage compartment or the highest engine enclosure of the highest aircraft which may occupy the hangar. The clearance to the bottom of the heater shall be measured from the upper surface of either the fuel storage compartment or the engine enclosure, whichever is higher from the floor.
- B. A minimum clearance of 8 ft must be maintained from the bottom of the heater to the floor in other sections of the aircraft hangar, such as offices and shops, which communicate with areas for servicing or storage. Refer to Section 1 for proper mounting clearances to combustibles.
- C. Heaters must be located so as to be protected from damage by aircraft and other objects, such as cranes and movable scaffolding.
- D. Heaters must be located so as to be accessible for servicing and adjustment.

## 3. INSTALLATION IN COMMERCIAL GARAGES AND PARKING STRUCTURES

Low Intensity Heaters are suitable for use in commercial garages when installed in accordance with the latest edition of the Standard for *Parking Structures*, ANSI/NFPA 88A, or the Standard for *Repair Garages*, ANSI/NFPA No. 88B, or the Canadian *Natural Gas and Propane Installation Code*, B149.1.



### WARNING

An overhead heater shall be located high enough to maintain the minimum distance to combustibles, as shown on the heater rating plate, from the heater to any vehicles parked below the heater.

Overhead heaters shall be installed at least 8 ft above the floor.

## 4. INSTALLATIONS OTHER THAN SPACE HEATING

Use for process or other applications that are not space heating will void the C.S.A. certification and product warranty. Process application requires field inspection and/or certification by local authorities having jurisdiction.



## WARNING



Improper installation, adjustment, alteration, service or maintenance can cause property damage, injury or death. Read and understand this installation and operation manual thoroughly prior to assembly, installation, operation or service to this appliance.



This heater must be installed and serviced only by a trained gas service technician.

Do not store or use gasoline or other flammable vapours and liquids in the vicinity of this or any other gas fired appliance.



Failure to comply could result in personal injury, death, fire and/or property damage.

Do not store or use gasoline or other flammable vapours and liquids in the vicinity of this or any other gas fired appliance.

## 5. PRE INSTALLATION SURVEY

It is recommended that a full heating design including heat loss calculation be conducted on the structure or area to be heated. Heater sizing and placement must consider available mounting height, sources of greatest heat loss, and the certified clearances to combustibles with respect to stored material, moveable objects (cranes, vehicles, lifts, overhead doors, etc), sprinkler system heads, and other obstructions on the site. Consideration must also be given to vent / duct placement and the allowable combined lengths of vent and duct. Carefully survey the area to be heated, and for best results place burner and combustion chamber in the coldest area(s) .

Installation must conform with all local, state, provincial and national code requirements including the current latest edition ANSI Z223.1 (NFPA 54) in the U.S.A. and B149.1 installation code in Canada, for gas burning appliances and equipment. The latest edition Electrical Code ANSI/NFPA N0 70 in the U.S.A. and PART 1 CSA C22.1 in Canada must also be observed.

The heating system must have gas piping of the correct diameter, length, and arrangement to function properly. For this reason, a layout drawing is necessary.

## 6. MOUNTING CLEARANCES

This heater must be mounted with at least the minimum clearances between the heater and combustibles as shown in FIG-1, TABLE 1, Page 7. It is the installer's responsibility to ensure that building materials with a low heat tolerance which may degrade at lower temperatures are protected to prevent degradation. Examples of low heat tolerance materials include vinyl siding, fabrics, some plastics, filmy materials, etc.

Positioning of lights, sprinkler heads, overhead doors, storage areas, gas and electrical lines, parked vehicles, cranes and any other possible obstruction or hazard must be evaluated prior to installation.

**Ensure adequate clearance around the air intake at the burner to allow sufficient combustion air supply to the heater.**

**6A. SERVICE CLEARANCE:** The lower 'jaw' of the burner cabinet swings down to provide convenient service access to burner components. Provide a minimum clearance from any wall or obstruction of 6 inches to the access end of the burner housing, and a minimum of 24 inches to any ONE side to allow servicing of burner, blower and controls. (see Figure 2) - the minimum clearances to combustibles must always be maintained.

For guidelines to heater placement refer to TABLE 2 (below).

**FIGURE 2**

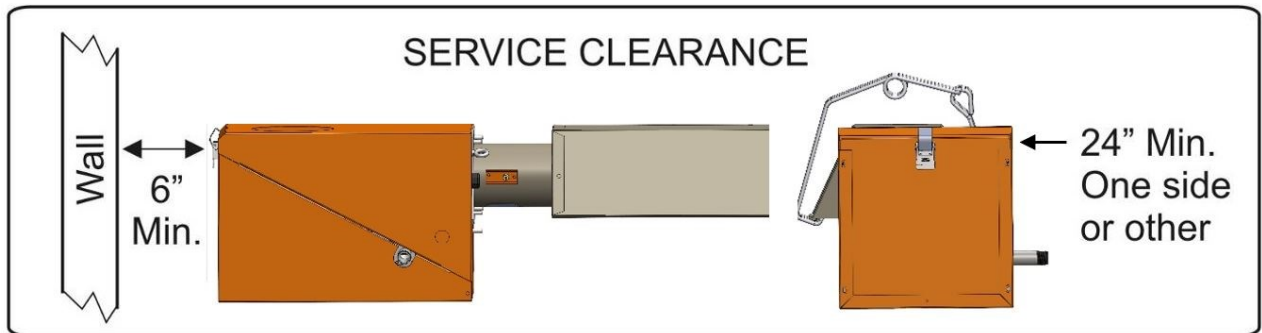

**TABLE 2: GUIDELINES FOR HEATER PLACEMENT**

MODEL “Straight” or “U-Tube”	MOUNTING HEIGHT ft	MAXIMUM DISTANCE BETWEEN HEATERS ft	DISTANCE – OUTSIDE WALL TO HEATER LONG AXIS (PARALLEL TO WALL) IN “FEET”	
			HORIZONTAL ft	ANGLE
S100 / ITB 200	18 – 25	50	17 – 25	COMBUSTIBLE CLEARANCE BEHIND (refer to Table 1)
S100 / ITB 175	18 – 25	50	17 – 25	
S100 / ITB 155	16 – 21	45	15 – 20	
S100 / ITB 130	15 – 21	40	15 – 20	
S100 / ITB 110	13 – 19	35	13 – 18	
S100 / ITB 100	13 – 19	35	13 – 18	
S100 / ITB 80	10 – 16	30	12 – 16	
S100 / ITB 60	8 – 14	25	11 – 15	
S100 / ITB 45	8 – 12	20	8 – 12	

- \* RECOMMENDED MOUNTING HEIGHTS are typical to provide optimum comfort in general space heating applications. Variance to these typical heights can occur in some applications:
- Higher mounting heights due to structure or application requirements
  - Lower mounting heights for area or ‘spot’ heat, or in areas with greater infiltration losses (near overhead doors, etc)



**IMPORTANT:** Single or multiple heater placement must be such that continuous operation of heater(s) will not cause combustible material or materials in storage to reach a temperature in excess of ambient temperature plus 90F° (50C°).

**It is the installer’s responsibility to ensure that building materials with a low heat tolerance which may degrade at lower temperatures are protected to prevent degradation. Examples of low heat tolerance materials include vinyl siding, fabrics, some plastics, filmy materials, etc.**

**Refer to “Clearance to Combustibles” information on pages 6 to 8, and Figure 1 and Table 1.**

**7. SYSTEMS INCORPORATING 90° ELBOWS AND 180° ELBOWS**

The radiant tube heater can be installed in configurations as illustrated in FIGURE 4. (below) with a maximum of two 90° elbows per heater. The use of elbows reduces the total maximum vent allowable. (See Section 11 : Flue venting)

90° elbows (JS-0528-SM) are shipped as a kit with one coupler, and two reflector end caps.

The S100 / ITB is available in a “U-Tube” model - S100U / ITBU - using a 180° turn box. A double wide reflector covers the double tube run. Alternately, for a 180° elbow, order 2 x 90° kits that connect to create a 180°.

**IMPORTANT:** Models with input 100 Mbh x 20 ft must only be installed as a straight system with no elbows allowed at the 10 ft location.



**Elbow Location / Input:** A minimum run of straight radiant tube must be connected to the burner before any elbow as follows: Inputs 200 (60 kW) and 175 Mbh (51 kW) = 25 ft (7.6 m); Input 150 Mbh (44 kW) = 20 ft (6 m); Inputs 125 Mbh (37 kW) and 110 Mbh (32 Kw) = 15 ft (4.6 m); and Inputs 80 Mbh (23 kW), 60 Mbh (18 kW), and 45 Mbh (13 kW) a minimum of 10 ft (3 m) straight tube before elbow.

**FIGURE 3 SYSTEM ELBOW KIT** - see page 50 for 180° elbow dimensions

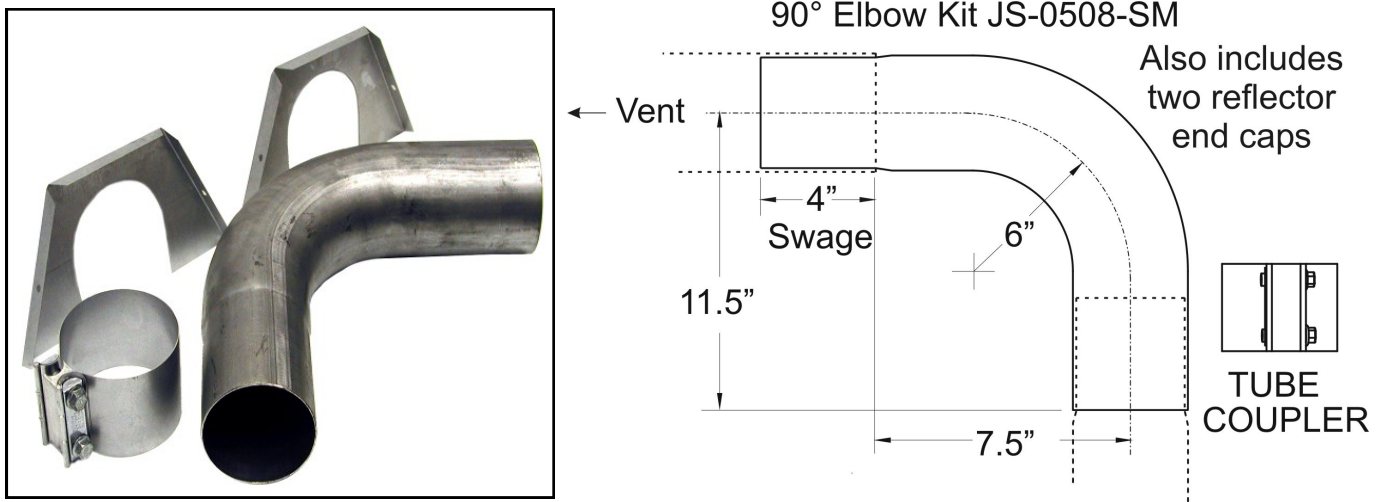

**FIGURE 4 90° ELBOW INSTALLATION**

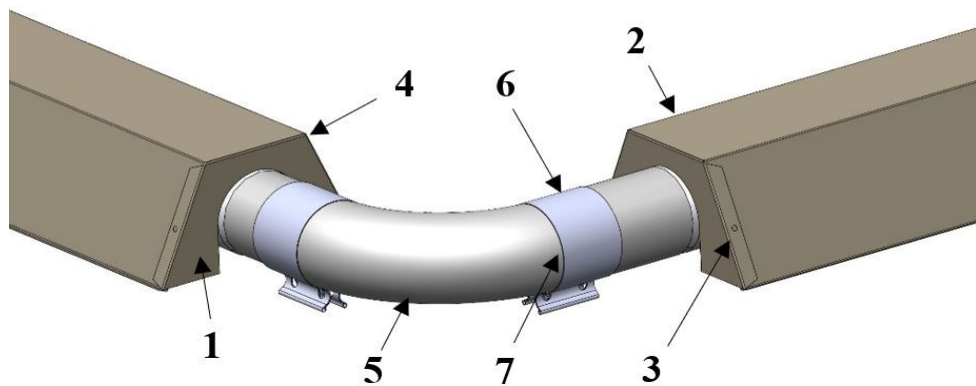

- |   |  |
|---|--|
| 1 End-Cap                               | 5 90° Elbow  |
| 2 Reflector                             | 6 Tube Coupler   |
| 3 End Cap Flange <u>OVER</u> Reflector  | 7 Unswaged end of elbow and tube (swage of previous tube or elbow inserted). |
| 4 End Cap Flange <u>UNDER</u> Reflector |  |

## 8. SUSPENDING THE SYSTEM - GENERAL



Inadequate or improper suspension of the tube heater can result in collapse of the system, property damage, and personal injury or death.

It is the installer's responsibility to ensure that the hardware and structural supports from which the heater is suspended are sound and of adequate strength to support the weight and expansion forces of the heater.

Consider that the heater will expand in length as much as 1/2 inch or more for every 10 ft of system length – typically the greater the firing rate, the greater the expansion.

**Refer to Sections 13 & 14**

- 1) Survey the available structural supports, considering the system configuration and heat requirements of the area to establish the optimum heater location.
  - a) Locating a heater directly under joists or beams, or installing supplemental steel support rail or angle iron can substantially reduce labor and materials
- 2) Hardware with a minimum 60 lb. (30 kg) work load must be used at each heater suspension point. A #8 Jack Chain or equivalent is typically used for suspending the heater.
  - a) Connect to the structure using typical hardware as illustrated in FIGURE 6 (below) or by other mechanically sound means
  - b) If rigid devices such as 3/8" threaded rods are used for suspension, swing joints or other means must be provided to allow for system expansion - approximately 1/2 inch to 1 inch for every 10 ft of system length.
- 3) Tube system hangers must be located:
  - i: Straight in line
  - ii: At a common height (level)

NOTE: It is important that the tubes in the system are installed in alignment horizontally (level) and vertically (in line) – this will ensure system integrity

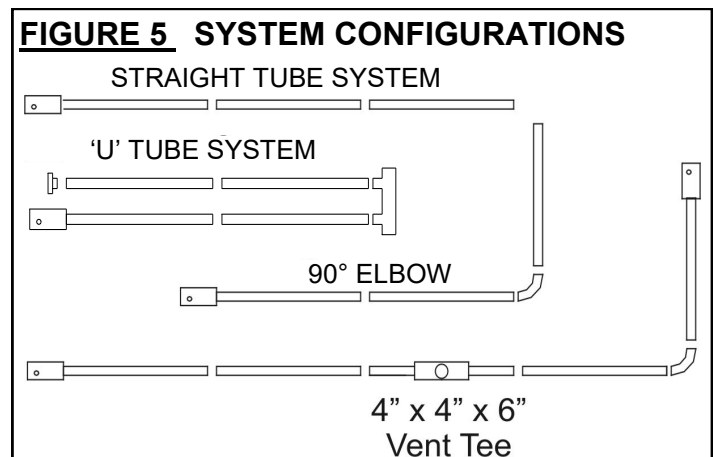

**FIGURE 6 TYPICAL MOUNTING HARDWARE**

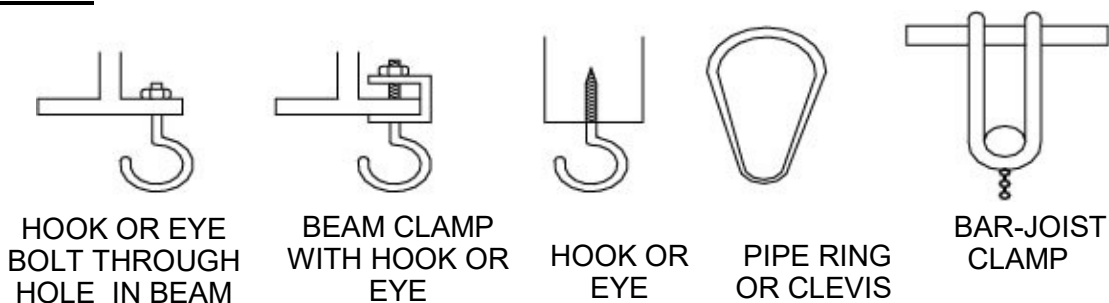

NOTE: It is the installer's responsibility to ensure that mounting hardware and fastening to structure are of sufficient strength to support the system.

## 9 INSTALLATION OF HANGERS, TUBES AND BURNER

### IMPORTANT SPECIAL NOTES: READ FIRST

1. S100/ITB **100 x 20 ft ONLY**: Special Tube Connection - Refer to Section 9.3, Fig 15
2. S100/ITB **175 & 200 ONLY**: Special Tube Connection - Refer to Section 9.4, Fig 16  
These input rates have an unpainted titanium alloy stainless steel first tube with a flange (painted "white"), and an unpainted aluminized steel tube as the second tube; all subsequent tubes are hot rolled steel. The first tube (titanium alloy stainless steel ) will "glow red" while heater is in operation - THIS IS A NORMAL CONDITION
3. Prior to installing the igniter and burner onto the flanged tube, **Install Flame Rectifier** included with burners: **NG & Propane - 60,000, 80,000, 110,000, 125,000; Propane ONLY - 200,000.**

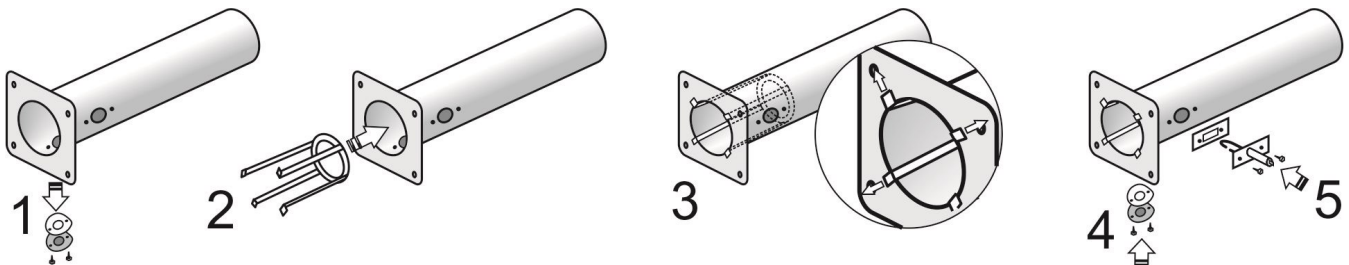

- 1 Remove & retain sight glass
- 2 Insert Flame Rectifier into tube

- 3 Feet of the flame rectifier seat against the tube flange and point toward flange corners

- 4 Reinstall sight glass
- 5 Install igniter with gasket into tube port

4. IF a 90° elbow is to be installed in the system, **refer NOW** to Section 7 and the Elbow Kit installation instructions supplied with the kit

### **TURBULATOR NOTES:** Also refer to Table & Illustration pages 49, 50 & 51

1. **60,000, & 80,000 Btuh:**
  - 30 ft heater: **REMOVE 5 FT TURBULATOR FROM THE 2ND TUBE (ALUMINIZED STEEL) IN THE SYSTEM. STEEL TUBE WITH 8 FT TURBULATOR INSTALLS AT VENT END.**
2. **200,000 x 60 ft & 70 ft: REMOVE SHORT PIECE OF TURBULATOR FROM UPSTREAM END OF LAST TUBE PRIOR TO INSTALLATION OF TUBE**
3. In a Tube Kit package tubes with turbulators are labelled as to their location in the system. Also refer to the TURBULATOR Table and Illustration in Sections 25A & 25B.

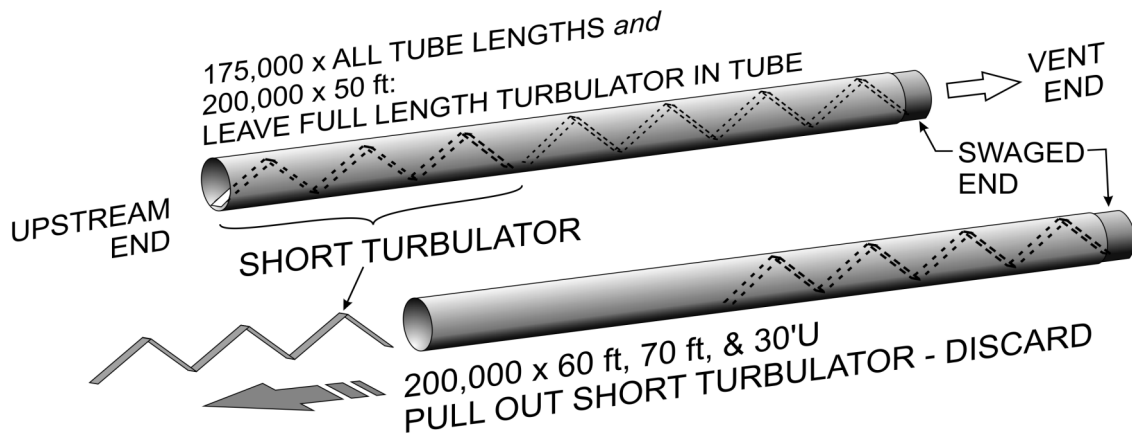

## 9.1 S100 / ITB STRAIGHT TUBE SYSTEM ~ BURNER AND TUBE INSTALLATION

For "U-Tube" Systems S100U / ITBU refer to section 9.2 page 17

### 1) Install Hangers:

- i: No closer than 3" and no further than 5" from the burner/tube flange
- ii: No closer than 6" either side of a tube connection in the system
- iii: No further than 24" either side of a tube connection in the system

### 2) With all hangers in alignment and suspended at the same height, insert first aluminized tube section, through 4" hole into first two wire hangers.

NOTE: INSTALL THE FIRST AND SECOND TUBES (FROM BURNER END) WITH THE WELDED SEAM ALONG THE TUBE LENGTH FACING DOWNWARD.

Labels on tubes identify those with turbulators and indicate their location in the system.

### 3) Bolt burner to flange on first tube section, SEE FIGURE 8.

**IMPORTANT NOTE:** Models with inputs 100,000, 175,000 & 200,000 refer to section 9.3- 9.4

### 4) Slide a Torctite tube coupler over the swaged end of the first tube, then join the second tube over the swage in the first tube

### 5) Slide the Torctite coupler into position across the center of the joint - SEE FIGURE 9

### 6) IMPORTANT: TOURQUE THE COUPLER BOLTS TO 40 ft-lbs

### 7) Subsequent lengths of tube can then be installed, by joining them together swaged portion inside the next tube and locking the joints using the Torctite coupler. SEE FIGURE 9.

### 8) If there is a 90° elbow in the system refer to Section 7 and Figures 3 & 4

**FIGURE 7: STRAIGHT TUBE TYPICAL HANGER & SUPPORT SPACINGS**

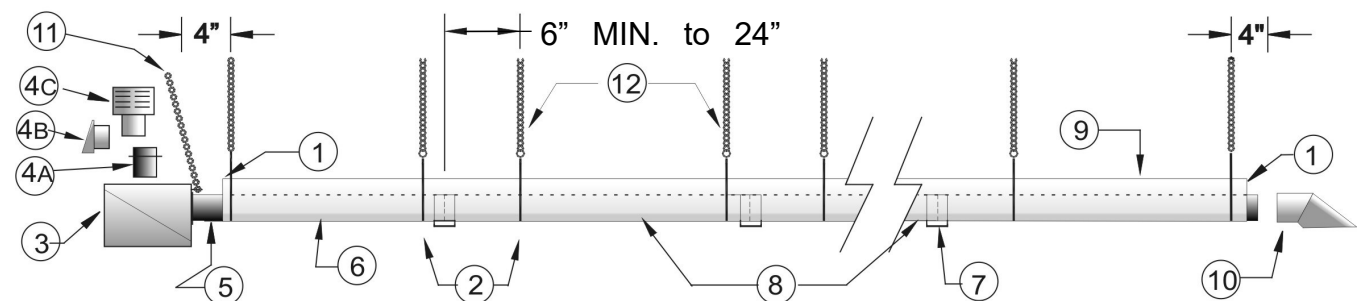

SUSPEND ALL TUBES BY TWO (2) HANGERS PER 10' LENGTH, LOCATE HANGERS BETWEEN 6" to 24" FROM EACH TUBE CONNECTION.

1ST & 2ND TUBES FROM BURNER END: INSTALL WELDED SEAM FACING DOWNWARD.

- |                             |                             |                           |
|-----------------------------|-----------------------------|---------------------------|
| 1 - END CAP                 | 4B - JS-0532-VC 4" WALL CAP | 8 - STEEL TUBE(S)         |
| 2 - WIRE HANGER             | 4C - JA-0530-XX 4" ROOF CAP | 9 - REFLECTOR             |
| 3 - BURNER ASSEMBLY         | 5 - SIGHT GLASS             | 10 - FLUE VENT TERMINAL   |
| 4 - COMBUSTION AIR OPTIONS: | 6 - ALUMINIZED TUBE WITH    | 11 - BURNER SUPPORT CHAIN |
| 4A - JS-0532-SE 4" INTAKE   | FLANGE                      | 12 - HANGER SUPPORT       |
| ADAPTER                     | 7 - TORCTITE TUBE COUPLER   | CHAINS                    |



### FIGURE 8: BOLT BURNER TO TUBE FLANGE

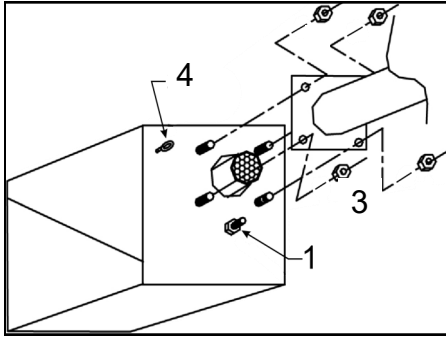

Note: A gasket is not required between burner and tube flange

1. Fifth Nut (Holds Inner Burner to Housing - Do Not Loosen or Remove)

2. Prior to installing the burner, **Install Flame Rectifier for inputs: NG & Propane - 60,000, 110,000, 130,000; Propane ONLY - 200,000:**

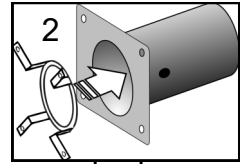

- Flame rectifier is supplied in burner kit when required
- Remove and retain the sight-glass assembly (2 screws)

- Insert flame rectifier into the tube with 'feet' pointed to the tube flange corners
- Reinstall the sight-glass assembly

3. Insert four burner bolts through the tube flange, secure tightly with lock nuts.
4. Secure suspension chain to eye bolt to stabilize burner
5. Install igniter with gasket on to tube

### FIGURE 9: COUPLER INSTALLATION (NOTE: See Section 9.3–9.4 for 'Special Couplers' at first tube joint: 100,000 x 20 ft & 175 / 200,000 models)

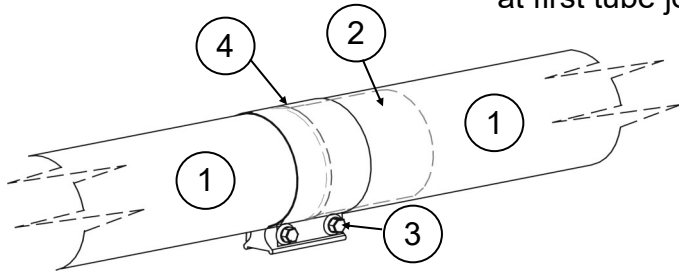

1. Tube
2. Swaged end of upstream tube
3. Tube Coupler
4. Centre coupler over tube joint

**Tighten coupler bolts to 40 ft-lbs.**

### FIGURE 10: HANGER / REFLECTOR ORIENTATION HORIZONTAL TO 45°

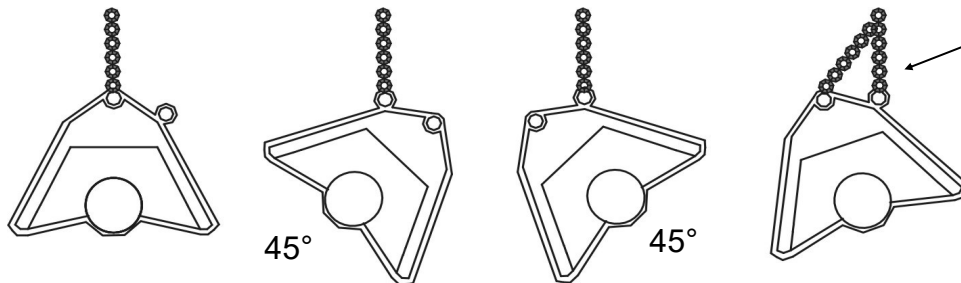

FOR ANGLE LESS THAN 45° USE CHAIN TO BOTH EYES ON HANGER



### 9.2 S100U/ITBU 'U'-TUBE SYSTEM ~ BURNER AND TUBE INSTALLATION For "Straight-Tube" Systems S100 / ITB refer to section 9.1 page 15

#### IMPORTANT SPECIAL NOTES: READ FIRST

1. S100U/ITBU 175 & 200 ONLY: Special Tube Connection - Refer to Section 9.4, Fig 16  
These input rates have an unpainted titanium alloy stainless steel first tube with a flange (painted "white"), and an unpainted aluminized steel tube as the second tube; all subsequent tubes are hot rolled steel. The first tube (titanium alloy stainless steel ) will "glow red" while heater is in operation - THIS IS A NORMAL CONDITION
2. **TURBULATORS:** Refer to Section 25 pages 49-50

*continued ....*

- 1) Install Hangers using chain or other suitable suspension hardware at each side of the hanger: See Figure 11 next page
- i: Two hangers for first section (from burner), and one hanger for each additional section
  - ii: No closer than 12" (30 cm) and no further than 14" (35 cm) from the burner/tube flange
  - iii: No closer than 6" (15 cm) from a tube connection in the system
  - iv: No further than 18" (61 cm) from a tube connection in the system
  - v: If angle mounting a 'U' Tube model, the vent side must be in the upper position

- 2) With all hangers in alignment and suspended at the same height (and angle), insert first aluminized tube section on to the first two hangers: See Figure 12A next page

- Also lay the vent end tube on to the first two hangers - check tubes for turbulator label to ensure the correct tube is located at the vent end

NOTE: INSTALL THE FIRST AND SECOND TUBES (FROM BURNER) WITH THE WELDED SEAM ALONG THE TUBE LENGTH FACING DOWNWARD

- 3) Fasten flanged tube to hangers with 'U' bolts:

- All tubes on the burner-side of the heater are bolted to the hangers with 'U' bolts
- Tubes on vent-side simply rest in the hanger notch and do not fasten to the hanger.

- 4) Bolt burner to flange on first tube section - SEE FIGURE 8 previous page.

**IMPORTANT NOTE: Models with inputs 175,000 & 200,000 refer to section 9.3**

- 5) Slide a Torctite tube coupler over the swaged end of the first tube, then join the second tube over the swage in the first tube -

- 6) Slide the Torctite coupler into position across the center of the tube joint - SEE FIGURE 9

- 7) **IMPORTANT: TOURQUE THE COUPLER BOLTS TO 40 ft-lbs**

- 8) Subsequent lengths of tube can then be installed on both sides of the hangers by joining them together swaged portion inside the next tube and locking the joints using the Torctite coupler. SEE FIGURE 9.

- 9) Install Turn Box: See Fig 12B

- The Turn Box has "long" and "short" tube legs
- The 'long' leg attaches to the burner-run tubes
- The 'short' leg attaches to the vent-run tube side - tubes end short of burner for connection of vent pipe

**FIGURE 11 'U'-TUBE TYPICAL HANGER & SUPPORT SPACING**

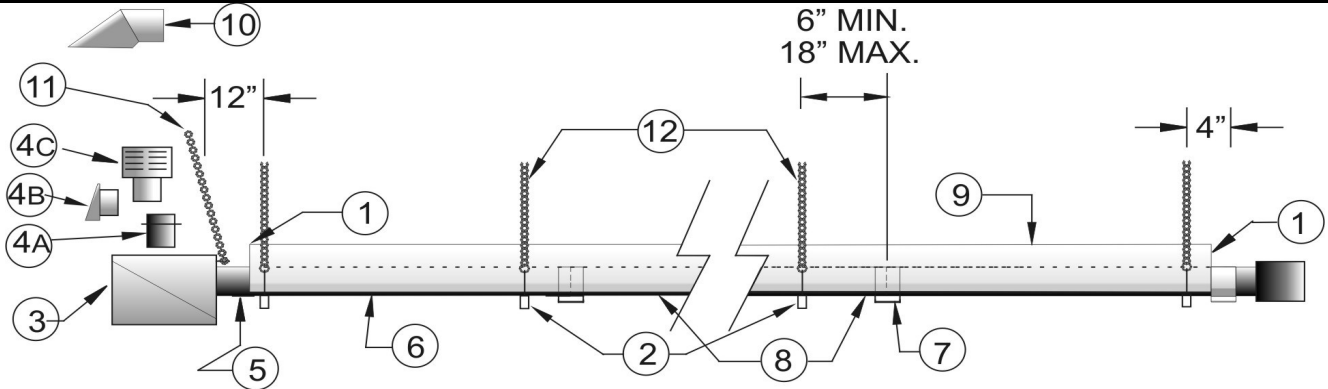

SUSPEND FIRST TUBES BY TWO (2) HANGERS, THEN SUBSEQUENT SECTIONS BY ONE HANGER

- LOCATE HANGERS BETWEEN 6" TO 18" FROM EACH TUBE COUPLER.
- INSTALL FIRST AND SECOND TUBES (FROM BURNER END) WITH WELDED SEAM FACING DOWNWARD.

- |                                   |                                 |                            |
|-----------------------------------|---------------------------------|----------------------------|
| 1 - END CAP                       | 4B - JS-0532-VC 4" WALL CAP     | 8 - STEEL TUBE(S)          |
| 2 - WIRE HANGER                   | 4C - JA-0528-XX 4" ROOF CAP     | 9 - REFLECTOR              |
| 3 - BURNER ASSEMBLY               | 5 - SIGHT GLASS                 | 10 - FLUE VENT TERMINAL    |
| 4 - COMBUSTION AIR OPTIONS:       | 6 - ALUMINIZED TUBE WITH FLANGE | 11 - BURNER SUPPORT CHAIN  |
| 4A - JS-0532-SE 4" INTAKE ADAPTER | 7 - TORCTITE TUBE COUPLER       | 12 - HANGER SUPPORT CHAINS |

**FIGURE 12: 'U' TUBE MODELS**

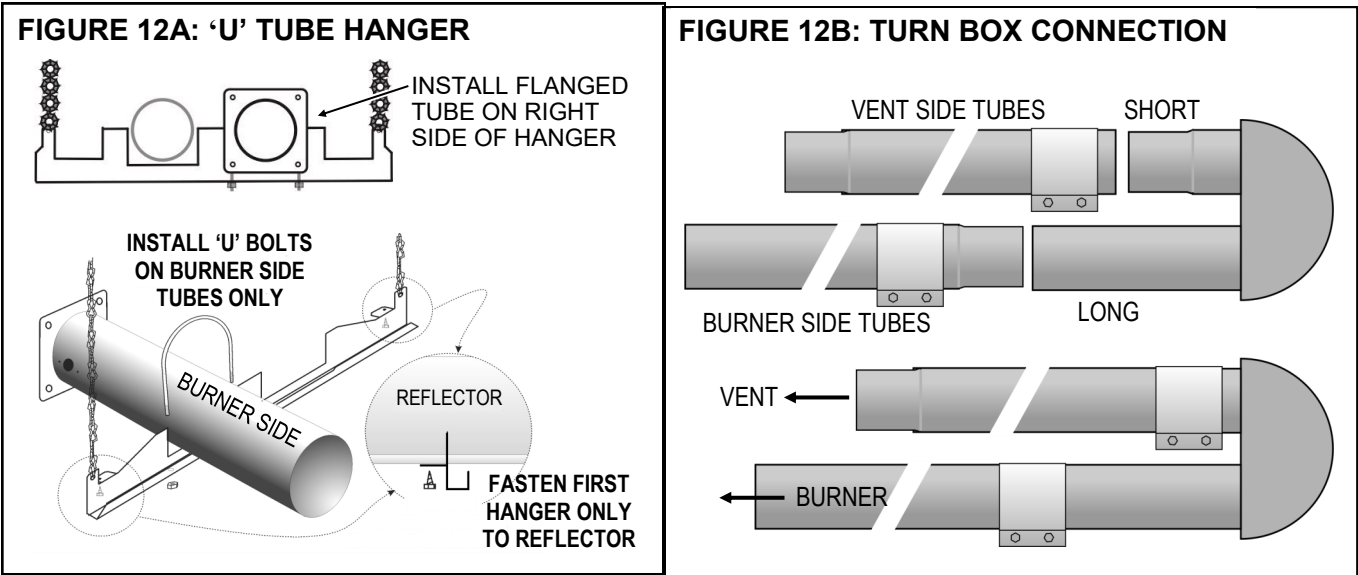

**FIGURE 13: 'U' TUBE MODEL ORIENTATION**

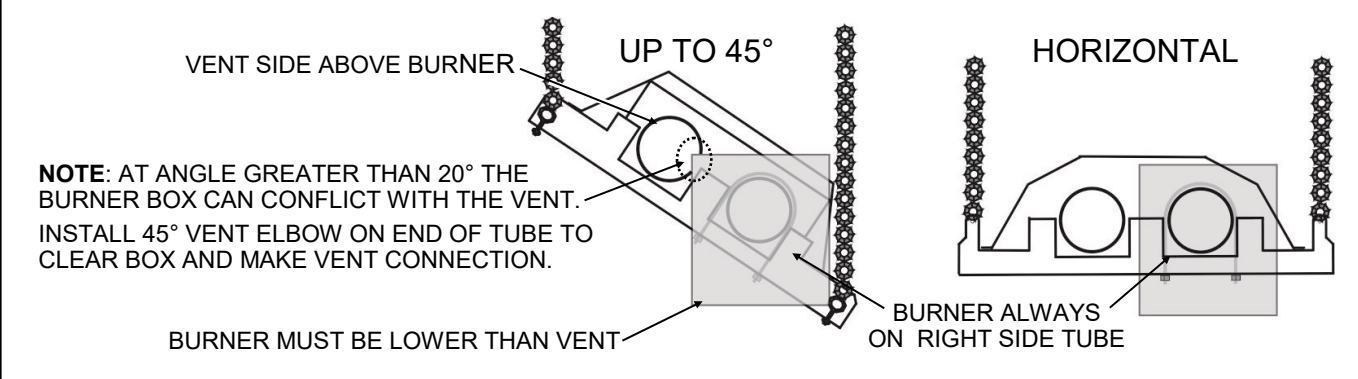



### 9.3 SPECIAL COUPLING: 100,000 Btuh x 20 ft

NOTE: The joint of 1ST & 2ND tubes of the 100,000 x 20 ft heater experiences strong forces of expansion. Follow instructions below for special coupling of the tubes and orientation of the turbulator in the 2nd tube..

#### SPECIAL COUPLER INSTALLATION

1. Install first tube so that the welded seam along the tube length is in the lower half of the tube facing downward
2. Slide the loosened tube coupler on to the first tube, past the swage
3. The second tube is supplied with a 1/4" hole in the tube at the female end.
4. Slide second tube over swaged end of first tube so that 1/4" hole is located 90° up from the bottom (3 or 9 o'clock position)
5. Note that the spine of the turbulator should be oriented in a vertical position
6. Through the existing 1/4" hole, drill a 1/4" hole through the wall of the first tube
7. Insert 1/4" rivet into the hole
8. Slide coupler into position – half onto each tube – covering the rivet head
9. Tighten coupler bolts to 40 ft-lb
10. Install reflectors

**TOOLS REQUIRED:** ✓ Electric Drill  
✓ 1/4" Drill Bit (supplied)

#### FIGURE 15 SPECIAL COUPLING:

- 100,000 x 20 ft

- Fasten Second Tube to First Tube -

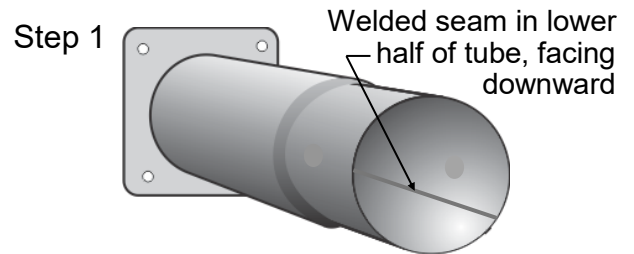

Steps 2 thru 6

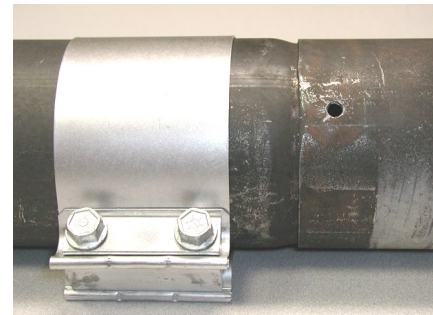

Step 7

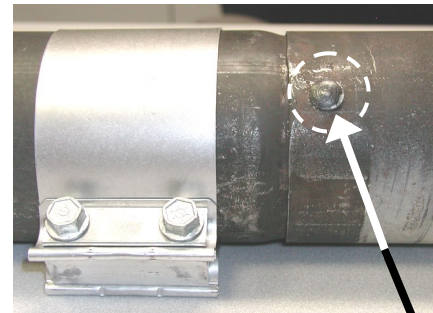

1/4" Rivet

Steps 8 & 9

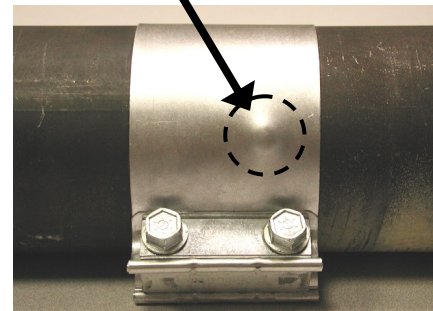

Step 5

#### NOTE: 100,000 Btuh x 20 ft Heater TURBULATOR ORIENTATION

100,000 Btuh x 20 ft  
Turbulator Location

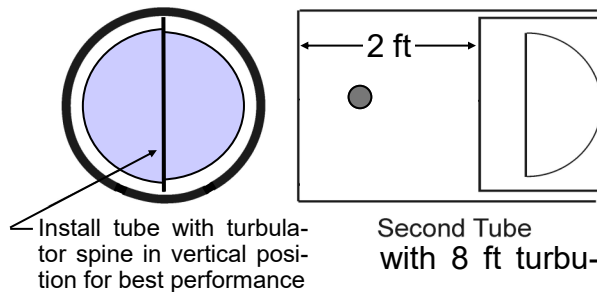

VIEW INSIDE TUBE: Ensure the 8 ft (2.4 m) turbulator installed in the second tube is oriented with its spine in a vertical position, and located at the vent end of the tube.

This will result in the best performance and radiant output from the system.



## 9.4 SPECIAL COUPLING: 175,000 & 200,000 Btuh

NOTE: The joint of 1ST & 2ND tubes of 175,000 & 200,000 heaters experience strong forces of expansion. Follow instructions below for special coupling of the tubes.

### SPECIAL COUPLER INSTALLATION

1. Note the 2 holes opposite each other at the swaged end of the first tube (flanged)
2. Install the **first tube** with 2 holes (swaged end) at the 3 and 9 o'clock position, with the **welded seam located in the lower half of tube, facing downward**
3. Slide the loosened tube coupler on to the first tube, past the swage
4. The second tube has a  $\frac{1}{4}$ " hole at the female end.
5. Slide second tube over swaged end of first tube to align the hole in the second tube with one of the holes in the first tube
6. Final alignment of the holes can be accomplished using a screw driver or other tool
7. **IMPORTANT:** Insert  $\frac{1}{4}$ " rivet into the hole to secure the tube connection
8. Slide coupler into position – half onto each tube – covering the rivet head
9. Tighten coupler bolts to 40 ft-lb
10. Install reflectors

### FIGURE 16 SPECIAL COUPLING:

- 175,000 & 200,000 Btuh - Fasten Second Tube to First Tube -

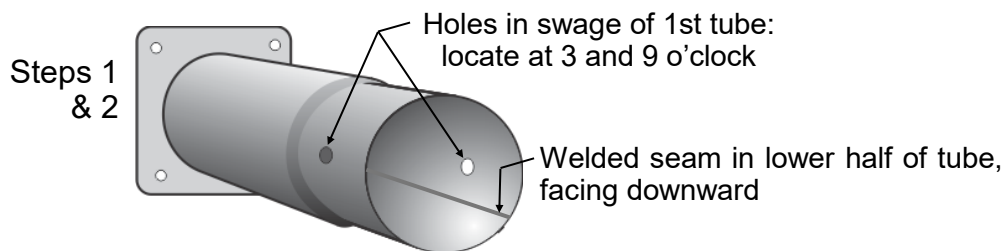

### Steps 3 to 6

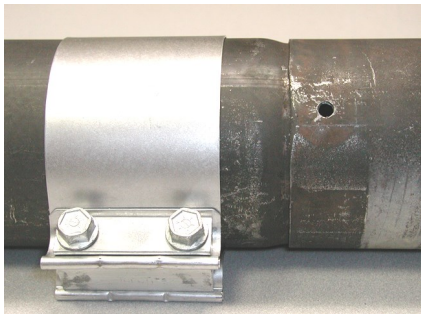

### Step 7

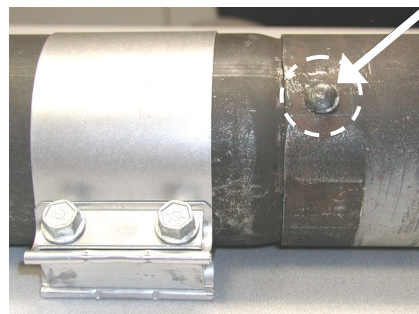

1/4" Rivet

### Steps 8 & 9

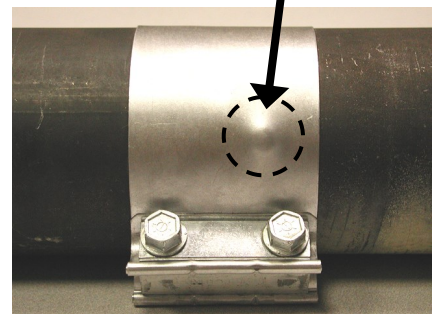

## 9.5 STRAIGHT TUBE SEISMIC RESTRAINT - LATERAL AND LONGITUDINAL

In areas prone to earthquake, or as specified on a project, install lateral and longitudinal seismic restraints as indicated in Figure 15. If the heater location can be impacted by wind (outdoors, aircraft hangars, etc) refer to High Wind Restraint Section 9.5, Figure 16.

These restraint systems indicate typical suspension of and attachment to the heater. Attachment of suspension hardware to the structure will be as required by site structural conditions, installation codes, and/or local engineering design requirements. Other material or systems of restraint may be specified by local or national codes, or by project engineering specifications.

Schwank / InfraSave offers optional items: #2 Lion Chain 115 lb work load x 200 ft roll (PN: JL-0800-XX); and Safety Snap Hooks (PN: JL-0800-SH = pkg 24; JL-0800-SH-B = pkg 100). Any and all other required seismic mounting hardware is field supplied by the installer.

**FIGURE 15**

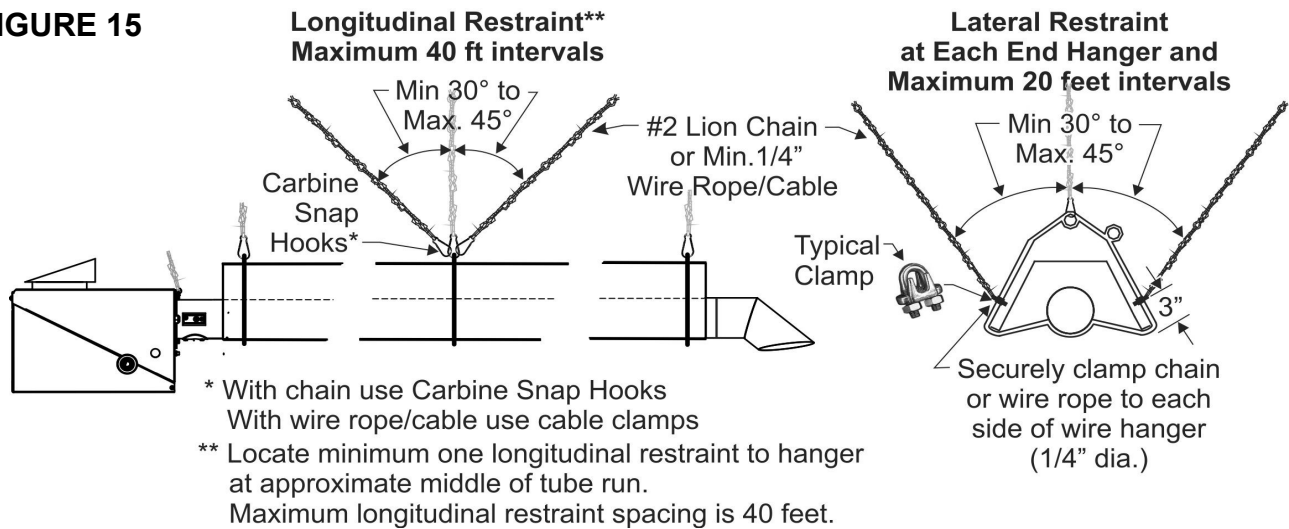

## 9.6 STRAIGHT TUBE HIGH WIND RESTRAINT - LATERAL, LONGITUDINAL, AND VERTICAL

In areas with wind conditions (aircraft hangars, etc) in addition to lateral and longitudinal restraint the heater must be restrained from vertical movement. Suspend the heater using 3/8" threaded rod with 3" adjustment turnbuckle through a safety ring at each hanger location.

**FIGURE 16**

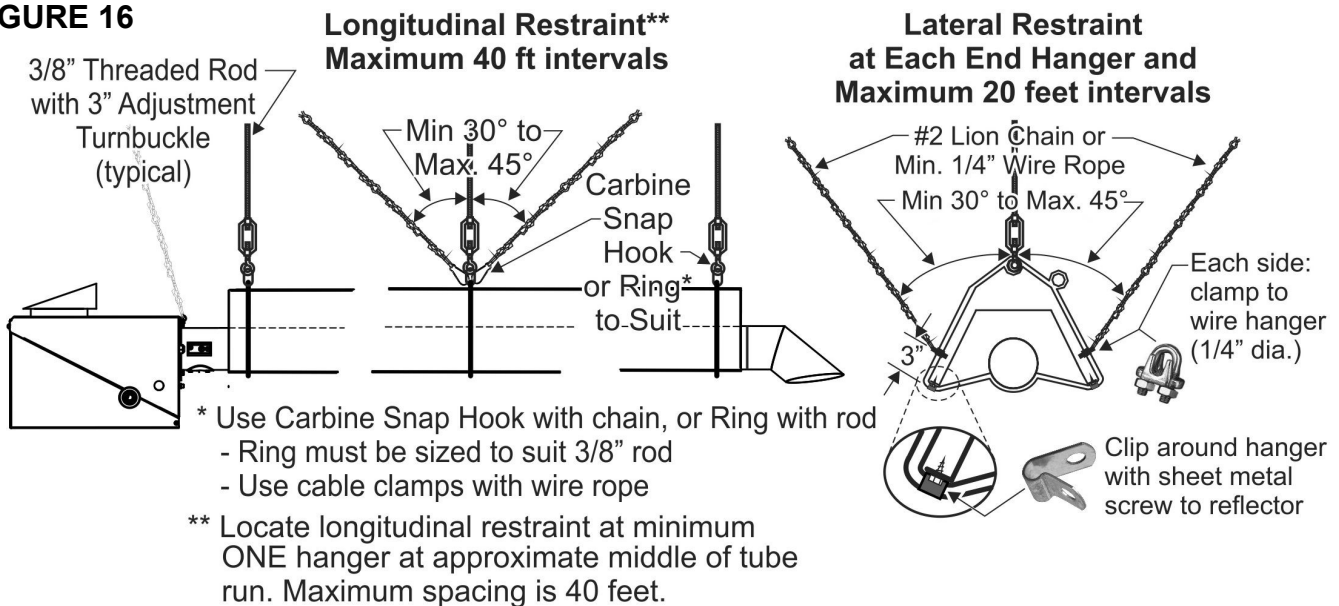

### 9.7 'U' TUBE SEISMIC RESTRAINT

In areas prone to earthquake, or as specified on a project, install lateral and longitudinal seismic restraints as indicated in Figures 17 & 18. Typical suspension of the 'U'-Tube heater is with #2 Lion Chain, or minimum 1/8" wire rope. If the heater location can be impacted by wind (outdoors, aircraft hangars, etc) then rigid suspension such as 3/8" rod with turnbuckle adjustment can be used to provide vertical restraint for the heater. In all cases, fasten reflector to the hangers using sheet metal screws

These restraint systems indicate typical suspension of and attachment to the heater. The attachment of suspension hardware to the structure will be as required by site structural conditions, installation codes, and/or local engineering design requirements. Other types or systems of restraint may be specified by local or national codes, or by project engineering design specifications.

Schwank / InfraSave offers optional items: #2 Lion Chain 115 lb work load x 200 ft roll (PN: JL-0800-XX); and Safety Snap Hooks (PN: JL-0800-SH = pkg 24; JL-0800-SH-B = pkg 100). Any and all other required seismic mounting hardware is field supplied by the installer.

**FIGURE 17**

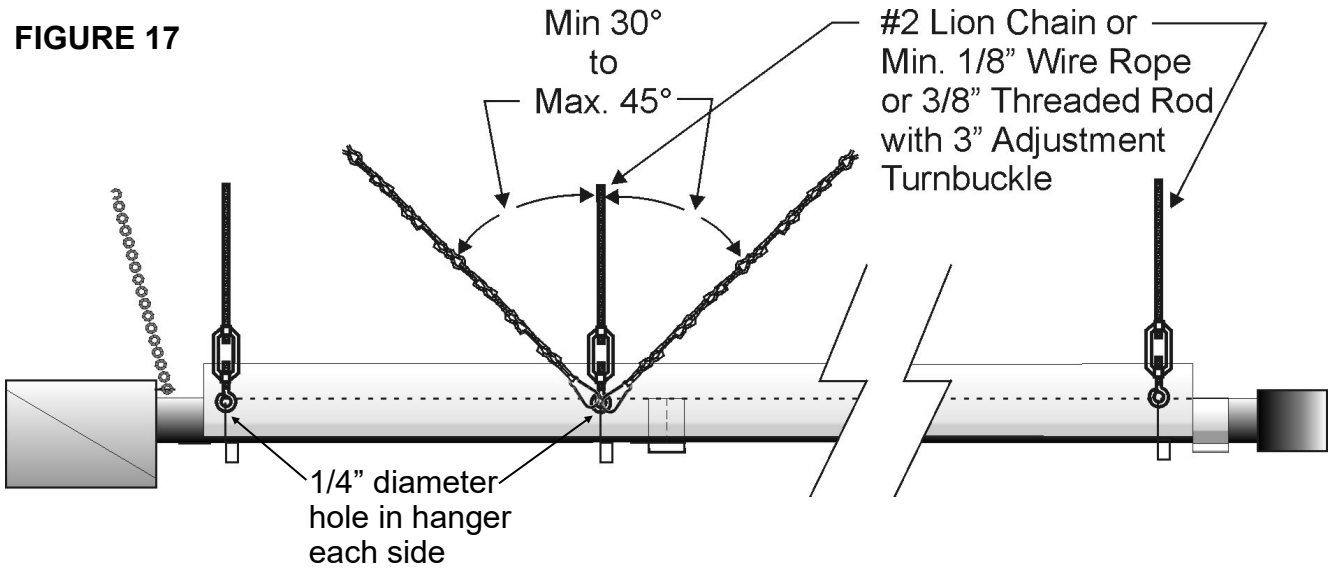

**FIGURE 18**

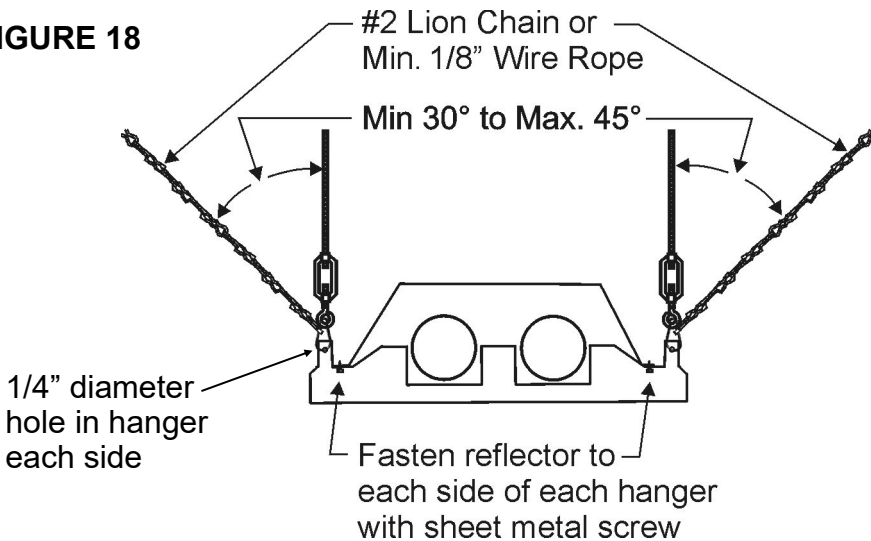

## 10. REFLECTOR INSTALLATION

**NOTE:** Ensure that you are installing a single reflector - reflectors can 'stick together' in packaging - take care to separate them.

**S100 / ITB - STRAIGHT TUBE:** After burner and tubes have been installed, slide the reflectors one at a time into the wire hangers. As each successive reflector is installed on an in-line installation, the ends of the reflectors will overlap to provide continuous coverage over the entire tube system. The overlapping joints **MUST BE FASTENED TOGETHER** with a sheet metal screw.

Note that for either horizontal or angle mounting of the reflector, the tube must be level along its length. Improper mounting can result in overheating of controls and combustible materials.

Reflector extensions can be added to the heaters as an option. *See instructions below*

**S100-U / ITB-U - U'-TUBE:** After burner and tubes have been installed, slide the double-wide reflectors one at a time onto the hangers. Fasten the FIRST hanger nearest the burner to the reflector with a sheet metal screw up through the hole in the tab at each end of the hanger.

**Do not fasten any other hangers in the system to reflectors.** SEE FIGURE 12A

As each successive reflector is installed, the ends of the reflectors will overlap to provide continuous coverage over the entire tube system. The overlapping joints **MUST BE FASTENED TOGETHER** with sheet metal screws - Note that for both horizontal and angle mounting, the tube must be level along its length. Improper mounting can result in overheating of controls and combustible materials.

Reflector extensions can be added to the heaters as an option. *See instructions below*

### **FIGURE 19 REFLECTOR EXTENSIONS (OPTIONAL - IF REQUIRED)**

#### **Reflector Extension Kit JS-0509-KT**

Includes:

- Qty 1 x 10 ft long x 10 inch deep reflector extension
- Qty 3 x "S" Hooks

1. Reflector extensions may be installed on one side or both sides of the reflector
2. Reflector extensions are 116" long
3. Holes (3) in the reflector extension for "S" hooks are located 2.25" from each end and one at the center
4. Drill 1/4" holes in the reflector 3/4" up from the bottom edge of the reflector to align with the 3 holes in the top of the reflector extension
5. Insert "S" hook down through hole in the top of the reflector extension
6. Rotate "S" hook approx. 90°, and insert into hole drilled in reflector
7. Settle reflector extension into place

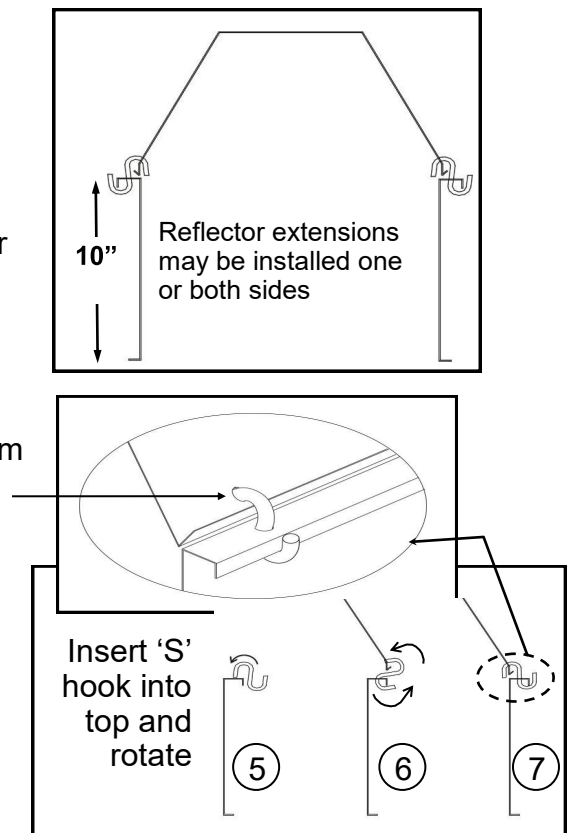



## 11. FLUE VENTING - RADIANT TUBE HEATER



### IMPORTANT

Effective January 1, 2019: Changes to the ANSI/CSA standard that governs Radiant Tube Heaters specify the following appliance CATEGORIES and VENTING:

- **Vertical Vent Through Roof (Category I):** For vertical vent, this tube heater series operates with a negative static vent pressure and a vent temperature that does not result in excessive condensate in the vent and is defined as a Category I appliance. Refer to details below.
- **Horizontal Vent Through Wall (Category III):** For horizontal vent, this tube heater series operates with a positive static vent pressure and a vent temperature that does not result in excessive condensate in the vent and is considered a Category III appliance. Refer to details below.



### WARNING

Inadequate venting of a heater may result in asphyxiation, carbon monoxide poisoning, injury or death. This heater may use a vent connection or indirect venting system to remove products of combustion from the space. Seal all vent connections with high temperature sealant. Venting must be in accordance with all local, state, provincial, and national codes (ANSI Z223.1/NFPA 54 in USA; B149.1 in Canada) and as indicated below in this manual.



**THIS TUBE HEATER IS CERTIFIED FOR VENTING DIRECTLY TO THE OUTSIDE OR UNVENTED (INDIRECT VENTING) APPLICATIONS.**

### UNVENTED (INDIRECT MECHANICAL VENTING SYSTEM)

**USA:** Natural or mechanical means shall be provided to supply and exhaust at least 4ft<sup>3</sup>/min/1000Btuh (0.38m<sup>3</sup>/min/kW) input of installed heaters. Some local codes may require an electrical interlock to a dedicated exhaust fan. Exhaust must be located as high as practicable in the structure above the level of the heater(s). Consult your local code and ANSI Z223.1 latest edition for all venting requirements and practices.

**Canada:** It is required that the heater(s) be electrically interlocked to dedicated exhaust fan(s) by means of an Air Proving Switch. Exhaust fan(s) must be sized to create 300 cfm (8.5 cu m/min) exhaust for every 100,000 Btuh (30 kW) or any fraction thereof of total input of installed equipment. Exhaust must be located as high as practicable in the structure above the level of the heater(s). Sufficient supply air must be provided. Consult the latest edition of CSA.B149.1 Section 8 for venting system and air supply requirements.

### VENTED TO THE OUTSIDE - GENERAL REQUIREMENTS

It is the responsibility of the installer to adhere to these instructions and all current local codes and/or ANSI Z223.1 (NFPA 54) or CSA.B149.1 latest editions for all venting requirements, and practices. All vent pipe will be certified to meet Category I (vertical vent) or Category III (horizontal vent) appliance requirements, depending on the vent configuration of a particular installation.

It is a normal condition that during heat-up and cool-down a tube heater will expand and contract. Allowances for heater expansion must be made in the venting and combustion air ducting. Improper installation can result in property damage, injury or death.

- When vented: The system must not be operated in a negative air condition unless combustion air is ducted from outside to the burner. If negative pressure is experienced or anticipated, the open port (barb) on each of the blocked flue and proving air switches must be Tee'd together and connected directly to outside air using a field supplied 1/4" plastic hose from the tee between the switches to outside of building.
- All approved vent pipe, connectors, and adapters are supplied locally by others according to appliance Category, and specifications below.
- All venting must meet requirements of Local Codes or, in the absence of local codes, with the *National Fuel Gas Code*, ANSI Z223.1/NFPA 54; or the *Natural Gas and Propane Installation Code* CSA B149.1.

- A vent connector shall comply with local codes and be firmly attached to the flue collar by 3 x 1/2" sheet metal screws. Seal penetrations and connections with high temperature RTV silicone sealant.
- Install a minimum 12" straight vent connector before any Tee or 90° Elbow.
- The connection of vent components must be secured as specified in the installation instructions by the vent manufacturer.
- For vertical vent, any horizontal vent section will slope upwards away from the heater not less than 1/4 inch rise per foot of run.
- For horizontal vent, slope downward away from heater a maximum of 1/4 inch down per foot of run.
- When the vent pipe passes through a cold or unheated area where the ambient temperature is likely to produce condensation of the flue gases, the vent pipe will be insulated with a suitable material as certified and specified by the insulation manufacturer to withstand temperature up to 460°F (238°C).
- The vent system must **always** be adequately supported to prevent sagging.
- The vent configuration will allow for expansion and contraction in length of the tube heater.
- As an Option for vertical vent, two heaters may be vented through an approved common 4" x 4" x 6" Vent Tee supplied by the manufacturer, or by using approved components as indicated in local codes. Vent pipe from each heater is not required to be equidistant to the vent Tee, but must comply with local code requirements. A common thermostat or "ON/OFF" switch must control commonly vented heaters. **Common vent is not allowed for Category III horizontal vent application.**

#### **COMBINED SYSTEM LENGTH: Tube Heater + Vent + Combustion Air Duct:**

- **Refer to Table 4 next page, COMBINED SYSTEM LENGTH: TUBE + AIR DUCT + VENT.** Lengths in the table apply to either Vertical or Horizontal vent.
- **COMBINED SYSTEM LENGTH includes:** Tube Heater length + combustion air duct + vent + elbows. Each 90° elbow in the system has an equivalent length of 5 ft.
- A maximum of 2 elbows is allowed in any portion (duct, tube heater, vent) with the exception of up to three 90° elbows in a vertical vent run through the roof, for a total of maximum 6 (vertical vent: 7) 90° elbows in the combined system.
- Combustion air duct is not to exceed lengths in table below and may be 4" or 5" diameter for inputs less than 200,000 Btuh, but must be 5" diameter for inputs 200,000 Btuh and greater.
  - 5" diameter duct requires a reducer to 4" diameter at the connection to blower inlet.
- Exceeding the allowable lengths in the table below can create combustion and/or condensation issues and will void Certification and the heater warranty.
- Do not exceed the **Maximum Combined System Length** regardless of the allowed maximum length of individual vent or combustion air duct.

**TABLE 4: COMBINED SYSTEM LENGTH**

*Installations up to 4500 ft - Higher altitudes refer to Section 27*

High Input Rate (Btuh)	Do Not Exceed Maximum Combined System Length		Max. Air Duct Length (by Duct Diameter)		Max. Vent Length Individual: 4"Ø OR Combined: 6"Ø from each heater	Example	
	Using 4" Air Duct	Using 5" Air Duct	4" Ø	5" Ø		150,000 Btuh Heater:	
45,000 & 60,000	<b>60 ft</b>	<b>80 ft</b>	20 ft	40 ft	20 ft	Tube Heater Length	50 ft
						1 x 90° elbow (vent)	5 ft
						Straight vent	20 ft
						1 x 90° elbow (duct)	5 ft
						Air Duct: 4" Ø	<u>17 ft</u>
80,000	<b>70 ft</b>	<b>90 ft</b>	20 ft	40 ft	20 ft	Combined Length	97 ft
110,000 to 150,000	<b>100 ft</b>	<b>120 ft</b>	30 ft	50 ft	30 ft	Max. Allowed	100 ft
175,000	<b>120 ft</b>	<b>140 ft</b>	30 ft	50 ft	40 ft	Additional 20' for 5" Ø Air Duct	
200,000	-	<b>130 ft</b>	Use 5"Ø	30 ft	40 ft		

**HEATER EXPANSION AND VENT CONFIGURATION**

A radiant tube heater will expand and contract as it heats and cools. Configuration of the vent must allow for heater expansion.

**VERTICAL VENT:** Orientation of the vent at 90° to heater will allow for heater expansion and contraction.

**HORIZONTAL VENT:** (See FIG. 22)

- Wall Thimble or flashing at wall that allows movement of the vent through the opening. Do not seal the vent to the thimble or flashing with caulking.

OR

- Offset vent with two x 90° elbows. Install minimum 12 inch length of straight vent between elbows. Vent can be sealed with caulking at non-combustible wall.
- Other means of slip fit installation of the vent are acceptable providing there is adequate allowance for free expansion and contraction of the system, and free flow of vent gases.

**FIGURE 20: ALLOW FOR HEATER EXPANSION - HORIZONTAL VENT - TOP VIEW**

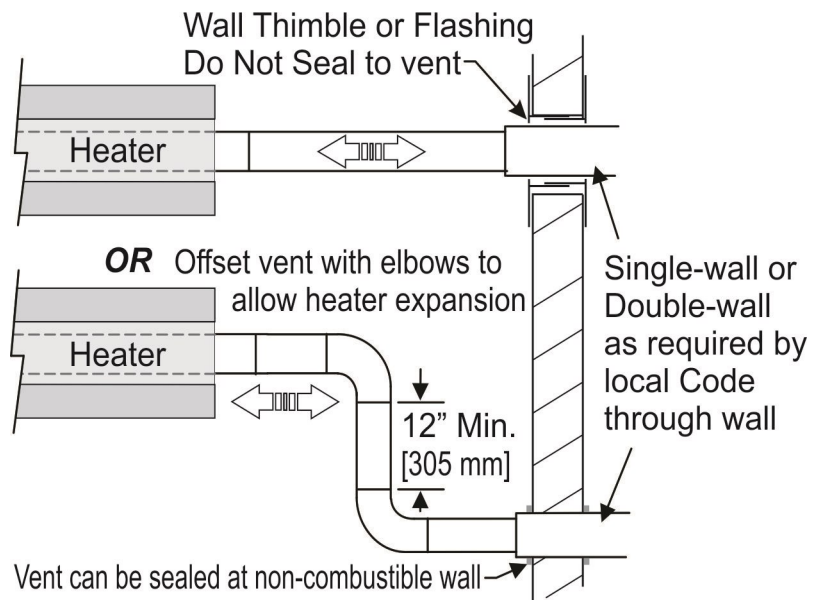

**COMMON VENTING**

For vertical vent only, two heaters can be commonly vented using 4"x 6"x 4" Vent Tee JA- 0514-XX. Both heaters must be operated using one common thermostat. Common vent is 6 inch diameter. Category III (horizontal vent) heaters cannot be common vented.

## VERTICAL VENT THROUGH THE ROOF (CATEGORY I):

It is the sole responsibility of the installer to adhere to all current local codes and/or ANSI Z223.1 / CSA.B149.1 latest editions for all venting requirements, and practices. Also adhere to instructions below, and the instructions of the vent manufacturer. Use vent materials certified for Category I.

All models of this series heater are certified Category I for vertical venting. See FIG. 21.

- The vertical Type B-vent must extend at least 5 feet above the flue collar of the highest connected heater.
- USA: Horizontal run of single wall vent or vent connector (“H” in FIG. 21) must not exceed 75% of the vertical height of the vent. If it does, then the vent system must be for Category III.
- Single wall vent connector material must be corrosion-resistant galvanized steel with a minimum thickness specified in local code.
- A vent connector must be secured to the flue collar using quantity 3 x #8 x 1/2” sheet metal screws. Seal penetrations and connections with high temperature RTV silicone sealant.
- A horizontal vent connector shall be installed and supported without any dips or sags and shall slope upward toward the vent or chimney at least 1/4 in./ft.a
- Use a certified termination cap as supplied by the manufacturer of the vent.
- When vent and combustion air are taken through the roof, the exhaust vent should always terminate higher than the combustion air intake, to prevent recycling the products of combustion back into the heater.
- The vent must extend at least 2 feet above the highest point where it passes through a roof. The vent must also extend at least two feet higher than any portion of a building within a horizontal distance of 10 feet (3 m).
- Keep vent connector runs as short as possible with a minimum number of elbows. Refer to the current edition of ANSI Z223.1 (NFPA 54) or CSA-B149 installation codes for maximum length of horizontal vent and vent connector.
- Total length of the vent connector and vent pipe cannot exceed the values in Table 4 above.
- A single-wall vent connector shall not be insulated.
- For single-wall vent clearance to combustibles is 6" except where a listed clearance thimble is used. Clearance to combustible material for Type B-Vent or factory-built vent per the vent manufacturer’s instructions.
- When an existing Category I heater is removed or replaced, the original venting system may no longer be sized to properly vent the attached appliances. Improperly sized venting systems can result in vent gas leakage or condensation.

**FIGURE 21: VERTICAL VENT**

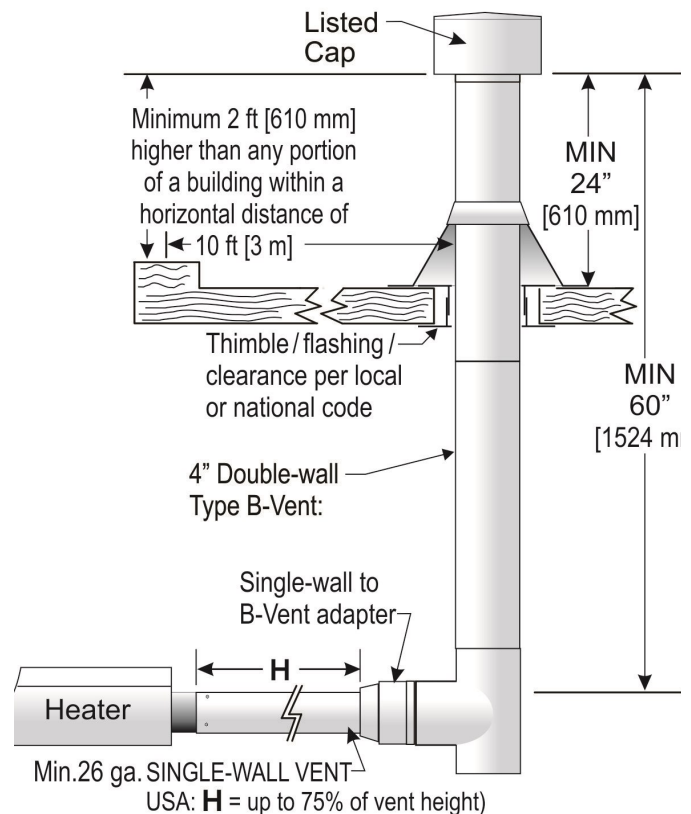

## **HORIZONTAL VENT THROUGH THE SIDEWALL (CATEGORY III):**

All vent must be installed in accordance with local codes or, in the absence of local codes, with the *National Fuel Gas Code* in the USA, ANSI Z223.1/NFPA 54; or the *Natural Gas and Propane Installation Code* CSA B149.1 in Canada.

When installed with a horizontal vent through a sidewall, this heater is a Category III appliance, and the vent system must be approved for Category III application in accordance with UL-1738 or ULC-S636. Do not use PVC or plastic vent pipe.

- Use either a certified Category III venting system, or single wall vent pipe with all of the joints and seams sealed with a heat-resistant pliable sealant.
- The vent system must be installed in accordance with these instructions, and the instructions of the vent manufacturer.
- A single wall vent system may use a single continuous 36 inch section of double wall vent pipe to pass through an exterior wall:
  - Single wall galvanized vent pipe (C-Vent): Minimum 26 ga.
  - Single Wall to Double Wall Adapter: Duravent 4PVP-AD Adapter or equivalent.
  - 36 Inch Double wall vent through outside wall: Duravent PelletVent Pro (PVP) or equivalent:
- Single-wall vent: Seal all joints and seams in the pipe, and the adapter with high temperature Red RTV sealant for temperatures up to 600°F (315°C). The sealant must remain pliable when in use. Follow the instructions of the vent manufacturer for sealing vent pipe connections.
- All vent sections and vent connector must be secured using quantity 3 x #8 x 1/2" sheet metal screws. Seal penetrations and connections with high temperature RTV silicone sealant.
- Any horizontal portion of the flue vent system must slope downwards away from the heater a minimum of 1/4" per foot run toward the vent terminal.
- Horizontally vented Category III heaters must be individually vented and cannot use a common vent.
- Use approved 4" (JA-0528-XX) horizontal wall vent terminal or an approved high-wind termination cap.
- Installation of the vent must prevent blockage by snow and protect building materials from degradation by flue gases.
- Install termination cap a minimum of 18 inches from the outside wall to the inside edge of terminal opening to alleviate back pressure caused by turbulent wind conditions (See Fig. 8). This also ensures flue gases are directed away from the structure to protect building materials from degradation by the exhausted flue gases.
- At most two 90° elbows can be installed in a horizontal vent.
- All seams and joints must be checked for gas tightness after installation. With the heater in operation, conduct a leak test on all vent connections, joints, and seams using a soap solution.
- A horizontal flue vent will not terminate less than 1 ft above grade level, unless its location is adjacent to a public walkway, then it must not terminate less than 7 ft above the walkway.
- Clearance above vent terminal under a combustible overhang or soffit:
  - As indicated in FIG. 6 for approved terminations: 4" JA-0528-XX.
  - For other approved terminations: Will terminate 3 ft or more below a combustible soffit or overhang.
- A horizontal vent termination must be a minimum of 6 feet from an inside corner formed by two exterior walls.
- All vent pipe, adapters, thimbles, supplied locally by others.

Specific requirements for horizontal vent in the USA and Canada are on the next page.

**USA** specific horizontal vent requirements:

- The vent terminal of an appliance with an input up to 50,000 Btu/hr (14.7kW) shall be installed with a 9 inch vent termination clearance from any air opening into a building, and an appliance with an input over 50,000 Btu/hr (14.7kW) shall have at least a 12 inch vent termination clearance. The bottom of the vent terminal and the air intake shall be located at least 12 inches above grade.
- A horizontal vent will not terminate:
  - Less than 3 ft above a mechanical air inlet located within 10 ft .
  - Less than 4 ft below, 4 ft horizontally from, and 1 ft above any window or door that opens, or gravity air inlet to a building.
  - Less than 4 ft horizontal clearance from gas and electric meters, regulators and relief equipment.

**CANADA** specific horizontal vent requirements:

- A horizontal vent will not terminate:
  - Within 6 ft of a mechanical air supply inlet to any building.
  - Above a gas utility meter and regulator assembly within 3 ft horizontally of the vertical centerline of the regulator vent outlet to a maximum vertical distance of 15 ft.
  - Within 3 ft of any gas pressure regulator vent outlet.
  - Within the following distances of a window or door that can be opened in any building, of any non-mechanical air-supply inlet to any building, or of the combustion air inlet of any other appliance:
    - 12 inches for inputs up to and including 100,000 Btuh (30 kW).
    - 3 ft for inputs exceeding 100,000 Btuh (30 kW).

**FIGURE 22: HORIZONTAL VENT THROUGH WALL**

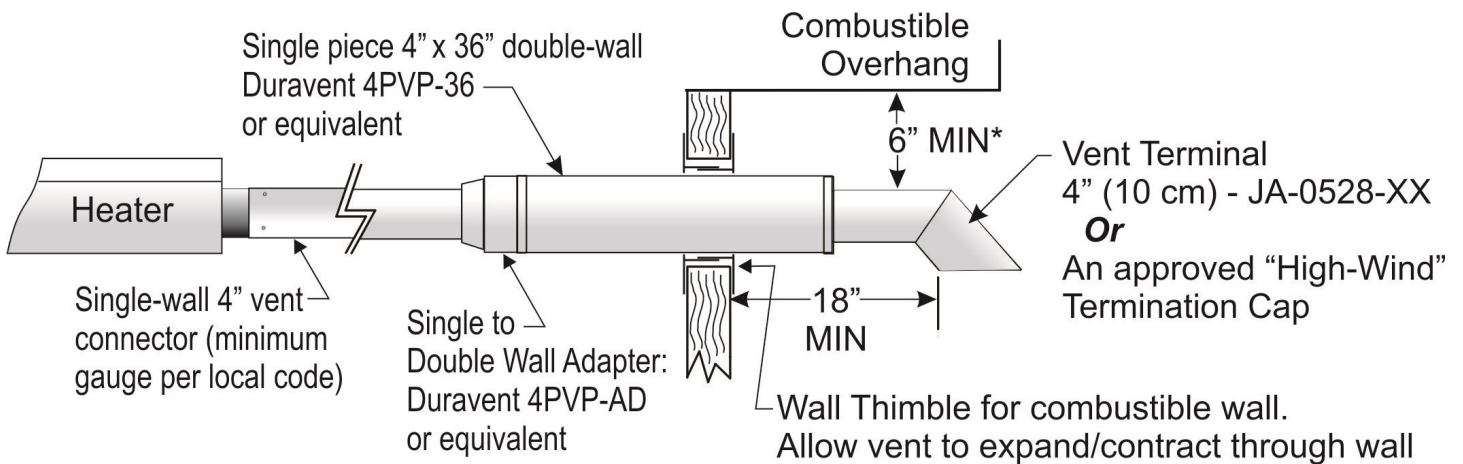

\* 6" Clearance above optional Vent Terminal JA-0528-XX - 4" (10 cm). Use of alternate High-Wind terminal may require higher clearance. Refer to Vent Cap manufacturer's instructions.

## 12. COMBUSTION AIR DUCTING

**Do not install filters on the combustion air intake. Ensure adequate clearance around the air intake to allow sufficient combustion air supply to the heater.**

**Standard air duct is 4" diameter, but can be increased to 5" diameter (reduce to 4" at burner) to provide up to an additional 20 feet of duct length. Vent size must remain at 4" for single vent or 6" for combined vent of two heaters - do not increase vent size.**

Combustion air duct must be constructed of noncombustible material. **Do not use a 'soft wall' flexible hose** for air duct, the corrugated sides of this tubing will contract and restrict air flow. A good quality industry approved hard-wall flex is allowed.

When a tube heater is operated in a negative air condition or air-borne dust or contaminants are present as in woodworking and welding shops, air for combustion must be ducted from outside the negative or contaminated area to the 4 inch diameter intake flange supplied on the blower. Maximum system, vent and duct length is listed above.

- Do not exceed lengths listed above for total system and individual vent or air duct
- Total combined system length is reduced by five feet for every 90° elbow installed in the vent or duct *and* in the tube system (see above for allowable total lengths)
- Exceeding the allowable lengths may create condensation or soot conditions and will void CSA Design Certification and product warranty

The air intake will not be located less than:

- Three feet above grade
- Twelve inches from flue vent terminal of any heater with input up to 100,000 Btu/hr
- Three feet from flue vent terminal of any heater over 100,000 Btu/hr

This heater has an optional fresh air intake duct hood for wall (JS-0532-VC) or roof cap (JS-0530-XX) to bring combustion air to the heater from outside. Ensure adequate clearance around the air intake to allow sufficient combustion air supply to the heater. If drawing fresh air from outside, it is recommended that any single wall pipe containing cold air be insulated to prevent or reduce condensation on the pipe.

### **CAUTION:**



In locations where chlorinated Hydrocarbons are in use, such as Trichloroethylene or Chloroethylene Nu it is essential that combustion air be brought in from a non-contaminated area. Burning the fumes from these gases will create Hydrochloric acid fumes, which are detrimental to humans, equipment and buildings. Typical sources of other contaminants are paint removers, paints, refrigerants, solvents, adhesives, degreasers, lubricants, pesticides, etc.



The heater manufacturer cannot anticipate all types and chemical composition of possible contaminants at project sites. Confer with project site safety, health and engineering staff and/or local authorities having jurisdiction such as the Fire Marshall and Department of Labor for possible contaminants and any conflict with the installation of hot surface heating equipment.

### 13. GAS SUPPLY - HEATER EXPANSION - FLEXIBLE GAS CONNECTION

The gas supply must be installed to the heater using:

- **USA:** an approved Stainless Steel Flexible Gas Connector certified for use on an infrared radiant tube heater (ANSI Z21.24 CSA 6.10);
- **CANADA:** an approved Type 1 Hose Gas Connector (CAN/CGA 8.1).
- The heater must be isolated from the gas supply piping system by closing its individual manual shut off valve (field supplied) during any pressure testing of the gas supply piping system.

**CAUTION:** Compensation for normal gas supply pipe expansion, and radiant tube heater expansion must be provided. All piping must conform to local codes.

Provide a 1/8 in NPT plugged tapping, accessible for test gauge connection, immediately upstream of the gas supply connection to the heater.



**DO NOT** use pressure greater than 1/2 psig to pressure check the heater.

**TEST FOR LEAKS:** All gas piping and connections must be tested for leaks after the installation is completed.



Apply soap suds solution to all connections and joints and if bubbles appear, leaks have been detected and must be corrected. **DO NOT USE A MATCH OR OPEN FLAME OF ANY KIND TO TEST FOR LEAKS. NEVER OPERATE THE HEATER WITH LEAKING CONNECTIONS.**



The supply system should be checked first with heater turned "OFF" followed by another check with heater turned "ON".

**IMPORTANT:** Minimum supply line pressure at the inlet to the heater regulator must not be lower than 5.0 inches of water column pressure for natural gas. The supply gas pressure must be checked with all heaters in operation.



Installation of a gas line (trap) "drip leg" is required at the inlet connection tee following the pipe drop to the heater. Failure to provide a "drip leg" could result in condensation and foreign matter passing into the gas valve. Failure to install a "drip leg" in the gas line can cause property damage, injury or death and will void the heater warranty.

**TABLE 5**

GAS TYPE	<u>LINE PRESSURE</u> INCHES WATER COLUMN		<u>MANIFOLD PRESSURE</u> (tap at gas valve outlet) INCHES WATER COLUMN
	MINIMUM	MAXIMUM	
Natural Gas	5.0	14.0	3.5



**NOTE:** Access to the manifold pressure test port is on the top of the valve. A 3/16" Allen Wrench is necessary to check this. When checking or setting the manifold pressure, a **water manometer** should be used. Gauges which measure in ounces per square inch or pounds per square inch are not accurate enough to properly measure or set the pressure.

 **WARNING**



**THIS HEATER WILL EXPAND IN LENGTH AS IT HEATS UP.** It is a normal condition that during heat-up and cool-down a tube heater will expand and contract. Allowances for heater expansion must be made in the gas connection, venting and combustion air ducting. Improper installation, alteration, or adjustment can result in property damage, injury or death.



The Btuh input and the tube length determine the overall expansion that occurs. A typical infrared tube installation will expand toward both the Burner and the vent end.



To allow heater expansion the gas supply must be installed using the flexible gas connector supplied in the burner kit:

**In the USA:** a stainless steel Flexible Gas Connector certified for use on an infrared radiant tube heater (ANSI Z21.24 CSA 6.10);

**in CANADA:** a Type 1 Hose Connector (CAN/CGA 8.1). Also the flue vent, and combustion air intake (if used) must be installed in such a manner that the normal expansion of the heater will be accommodated.



**IMPORTANT:** See next page: orientation of connection between heater and gas supply.

**TABLE 6**

Input Rating Btuh	Tube Length Feet	Approx. Expansion in Length	USA: Mandatory Flexible Gas Connector ID x Length - Part #	CANADA: Mandatory Type '1' Gas Hose Size - Part #
45,000	20	1 1/4"	1/2" x 24" - JL-0771-XX	1/2" x 30" - JL-0771-RC
60,000	20 / 30	1 1/2"	1/2" x 24" - JL-0771-XX	1/2" x 30" - JL-0771-RC
80,000	20 / 30 / 40	1 3/4"	1/2" x 24" - JL-0771-XX	1/2" x 30" - JL-0771-RC
100,000	20	2"	1/2" x 24" - JL-0771-XX	1/2" x 30" - JL-0771-RC
110,000	30 / 40 / 50	2"	1/2" x 24" - JL-0771-XX	1/2" x 30" - JL-0771-RC
125,000	30 / 40 / 50	2"	1/2" x 24" - JL-0771-XX	1/2" x 30" - JL-0771-RC
150,000	40 / 50 / 60	2 1/2"	3/4" x 36" - JL-0771-YY	3/4" x 30" - JL-0771-RB
175,000	50 / 60 / 70	2 3/4"	3/4" x 36" - JL-0771-YY	3/4" x 30" - JL-0771-RB
200,000	50	2 3/4"	3/4" x 36" - JL-0771-YY	3/4" x 30" - JL-0771-RB
200,000	60 / 70	3 1/4"	3/4" x 36" - JL-0771-YY	3/4" x 30" - JL-0771-RB

**FIGURE 23 ORIENTATION OF FLEXIBLE GAS CONNECTOR**



The flexible gas connector **MUST** be installed in the orientation shown below as required by national installation codes and by the certification standard of this heater. This orientation protects the flexible gas connector from damage due to movement during heater expansion.

It is the responsibility of the installer to ensure correct installation of the flexible gas supply.

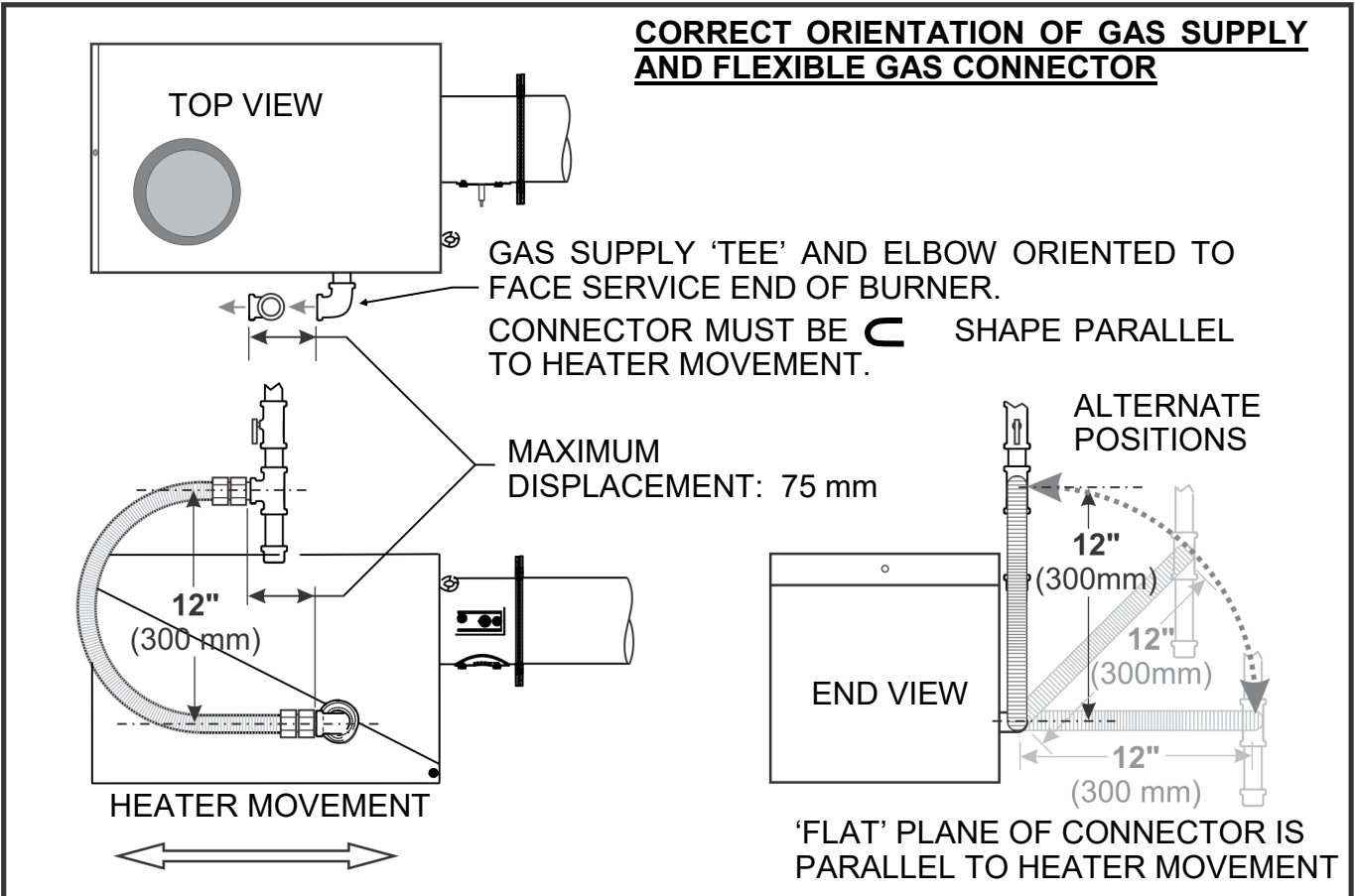

**WARNING:** CONNECTOR MUST BE INSTALLED IN A "C" CONFIGURATION. USE ONLY THE CONNECTOR OF PROPER LENGTH AND DIAMETER AS INDICATED IN TABLE 5 ON THE PREVIOUS PAGE.

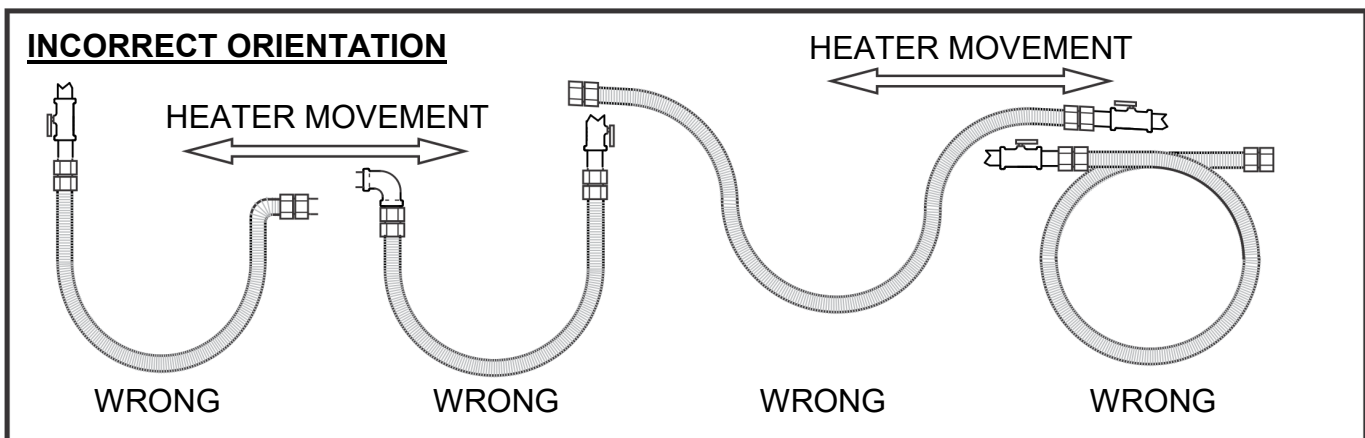

## 14. ELECTRICAL AND THERMOSTAT WIRING (WIRING DIAGRAMS PAGES 35 & 36)



The heater must be electrically grounded in accordance with the National Electrical Code. ANSI / NFPA 70 or current Canadian Electrical code CSA C22.1.

Appliance and control wiring must be in accordance with all applicable local codes. The total load of all heaters must be considered in determining the required contact rating of the controlling thermostat or switch. Each tube heater requires 120V, 60 HZ electrical power sized for 145VA. Maximum power flow for internal 24V burner components is 21VA.

The ignition control includes a 24V/120V relay switch that provides a 45 second post-purge of the system. **A 24V Thermostat, TruTemp Thermostat, or 24V controller signal must be used for the post-purge feature to function.** A line voltage Thermostat or an "ON/OFF" switch will disable the post-purge feature.

A maximum night set-back of 9°F (5°C) is recommended for optimum economy and comfort. To maintain satisfactory comfort levels do not turn off the heating system over night/weekends.

## 15. HIGH ALTITUDE INSTALLATIONS - Refer to chart in Section 26 for Restrictions

When installed above the altitude stipulated below, the input must be de-rated by 4% for each 1000 ft above the altitude listed. Refer to the tables in Section 28 for orifice size and restrictions that apply to high altitude installation (including total system length restrictions). Check with your local utility regarding the gas supply and the de-rating of this appliance. Maintain gas supply pressure indicated in Table 4, page 33.

**USA:** The factory installed orifice for this appliance is approved for altitudes zero to 2000 feet above sea level. When installed above 2000 feet, **refer to Section 26.**

**Canada:** The factory installed orifice for this appliance is approved for altitudes zero to 4500 feet above sea level. When installed above 4500 feet, **refer to Section 26.**

## 16. LIGHTING INSTRUCTIONS

Refer to the lighting instructions label on the outside of the burner housing. If the unit locks out on safety, main power to the unit must be manually interrupted for a 30 second reset period before the heater can be restarted.

**NOTE:** *On initial installation, the unit may lock out on safety owing to the length of time required to bleed air from the gas piping system.*

## 17. RECOMMENDED MAINTENANCE



Improper adjustment, alteration, service or maintenance can cause property damage, injury or death. This heater must be installed and serviced only by a trained gas service technician.

1. Inspect the entire heater system, venting, and gas supply connections at least annually prior to the heating season. Replace worn parts and repair deficiencies.
2. Check the inlet air opening and the blower periodically, cleaning off any lint or foreign matter. It is important that the flow of combustion and ventilation air must not be obstructed.
3. Lubricate Blower motor, by adding several drops of oil to oil ports located on the left hand side of the motor.

THE TUBE HEATER BURNER IS COMPLETELY FACTORY ASSEMBLED AND TESTED. ANY ALTERATION VOIDS THE CSA CERTIFICATION AND MANUFACTURER'S WARRANTY. FOR ADDITIONAL INFORMATION, CONTACT YOUR LOCAL DISTRIBUTOR OR THE MANUFACTURER.

**18. FENWAL DSI: WIRING DIAGRAM: 24V OR 120 VOLT THERMOSTAT OPERATION SINGLE HEATER PER THERMOSTAT** (Multiple Heaters per Thermostat—next page)

NOTE: Models produced with FENWAL DSI have model designation: S100-F & ITB-F

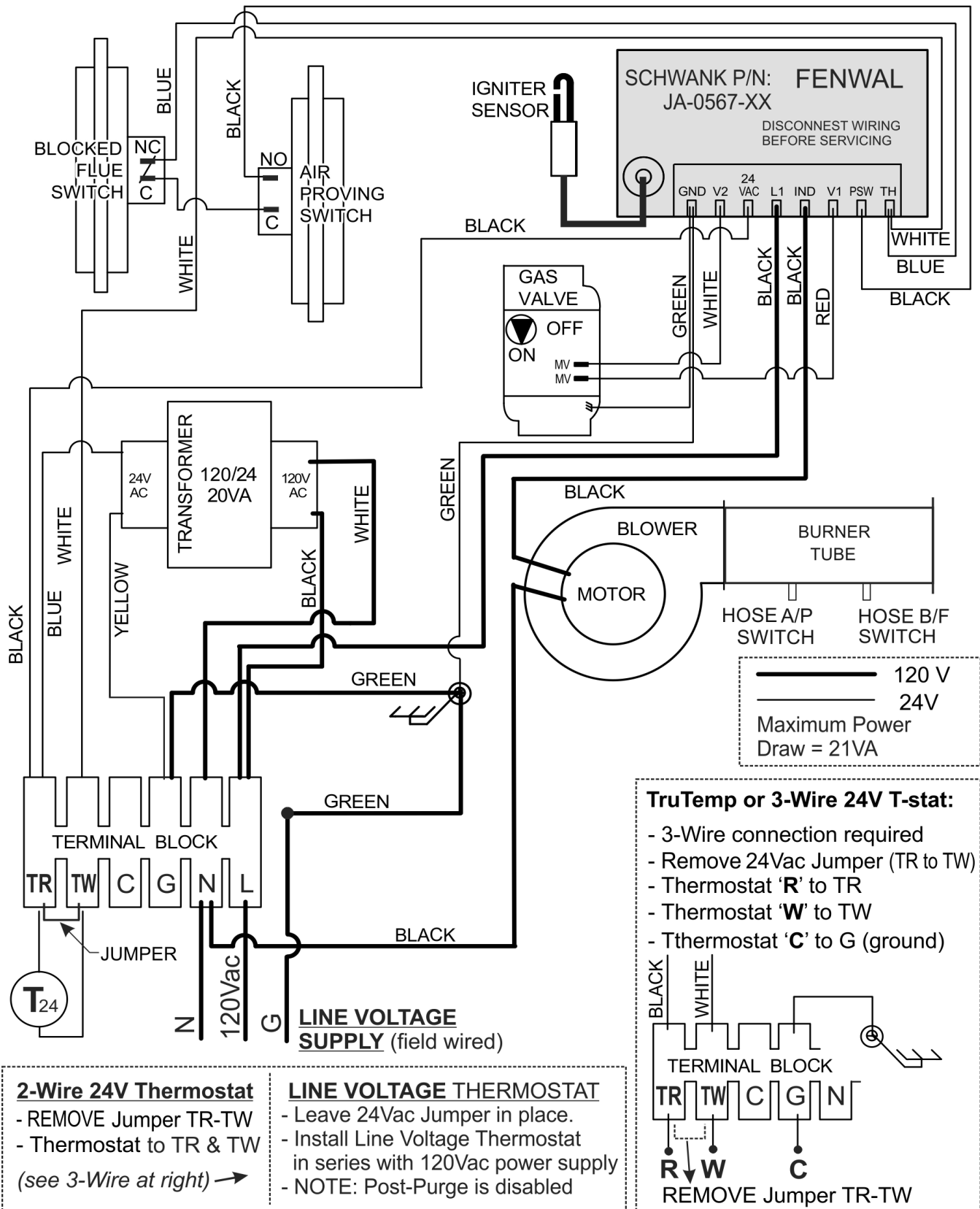



## **19. FENWAL DSI: SEQUENCE OF OPERATION / FLAME RECOVERY / SAFETY LOCKOUT**

### **Power Up / Stand By**

Upon applying 24 volts power to 24VAC, the control will reset, perform a self check routine, initiate full time flame sensing, flash the diagnostic LED for up to four seconds, and enter the thermostat scan state.

### **Heat Mode**

When a call for heat is received from the thermostat supplying 24 volts to TH, the control checks the pressure switch for normally open contacts. The combustion blower is then energized and once the pressure switch contacts close, a 30 second purge delay begins. Following the purge period the gas valve is energized and spark commences for the 15 second trial for ignition.

When flame is detected during the trial for ignition, spark is shutoff immediately and the gas valve combustion blower remains energized. The thermostat, pressure switch, and main burner flame are constantly monitored to assure the system continues to operate properly. When the thermostat is satisfied and the demand for heat ends, the main valve is de-energized immediately, the control senses the loss of flame signal and initiates a 30 second post-purge period before de-energizing the combustion blower.

### **Failure to Light - Lockout (THREE TRIAL MODEL)**

This three-try control will attempt two additional ignition trials with a 30 second inter-purge between trials, before going into 'soft' lockout. The valve relay will be de-energized immediately, and the combustion blower will be turned off following the 30 second post purge period.

If the thermostat continues to call for heat after one hour the control will automatically reset and attempt to ignite the burner again (three trials).

At any time less than the 1 hour auto-reset, recovery from lockout requires a manual reset by either resetting the thermostat or removing 24 volts for a period of 5 seconds.

### **Flame Failure - Re-Ignition**

If the established flame signal is lost while the burner is operating, the control will respond within 0.8 seconds. The HV spark will be energized for a trial ignition period in an attempt to relight the burner. If the burner does not light the control will de-energize the gas valve. Two more attempts will be made to relight the burner. If the burner does not relight the control will go into 'soft' lockout as noted above in "Failure to Light". If flame is re-established, normal operation resumes.

### **Combustion Airflow Problems -Lockout**

Combustion air flow is continually monitored during an ignition sequence by the air flow switch (PSW). If during the initial call for heat the pressure contacts are in the closed position for 30 seconds without an output to the Combustion Blower, an air flow fault will be declared and the control will remain in this mode with the combustion blower off.

If the air flow switch remains open for more than 30 seconds after the combustion blower output (L1 & IND) is energized, an air flow fault will be declared and the control will stay in this mode with the combustion blower on, waiting for the air flow switch to close.

When proper air flow is detected from the air flow switch input (PSW) the control begins the pre-purge period followed with a 15 second ignition sequence.

If the air flow signal is lost while the burner is firing, the control will immediately de-energize the gas valve and the combustion blower will remain on. If the call for heat remains, the control will wait for proper air flow to return. If proper air flow is not detected after 30 seconds an air flow fault signal will be declared. If proper air flow is detected at any time, a normal sequence will begin with the pre-purge period.

## Flame Fault

If at any time the main valve fails to close completely and maintains a flame, the full time flame sense circuit will detect it and energize the combustion blower. Should the main valve later close completely removing the flame signal, the combustion blower will power off following the optional post purge period.

## Fault Conditions

The LED will flash on for 1/4 second, then off for 1/4 second during a fault condition. The pause between fault codes is 3 seconds.

Error Mode	LED Indication
Internal Control Failure	Steady on
Air Flow Fault	1 flash
Flame with No Call for heat	2 flashes
Ignition Lockout	3 flashes

## MOUNTING AND WIRING

The Series 35-61 is not position sensitive and can be mounted vertically or horizontally. The case may be mounted on any surface with #6 sheet metal screws. All wiring must be done in accordance with local and national electrical code. Refer to wire diagram page 35 when connecting the Series 35-61 to other components in the burner.



## WARNING

The Series 35-61 DSI Control uses voltages of shock hazard potential. Wiring and initial operation must be done by a qualified service technician. The control must be secured in an area that will experience a minimum of vibration and remain below the operating temperature of 160°F. All connections should be made with UL approved 105°C rated 18 gauge, stranded, .054 thick insulated wire. Refer to wire diagram page 35 when connecting the Series 35-61 to other components in the burner.

TERMINAL	SPADE	DESIGNATION
TH	1/4"	Thermostat Input
PSW	1/4"	Pressure Switch Input
V1	1/8"	Valve Power (MV)
IND	1/4"	Inducer Blower Output
NC	-	Alarm (Not used)
L1	1/4"	120/240 VAC Input (Hot)
24 VAC	1/4"	24 VAC Supply to Processor
V2	1/8"	Valve (MV)
GND	1/8"	Valve & System Ground
Spark	1/4"	Spark & Local Flame Sense

## CAUTION:

Label all wires prior to disconnection when servicing controls. Wiring errors can cause improper and dangerous operation. A functional checkout of a replacement control is recommended.

## PROPER ELECTRODE LOCATION

Proper location of the electrode assembly is important for optimum system performance. The electrode assembly should be located so that the spark gap is inside the flame envelope about 1 inch (2.5 cm) from the base of the flame at the burner cup.

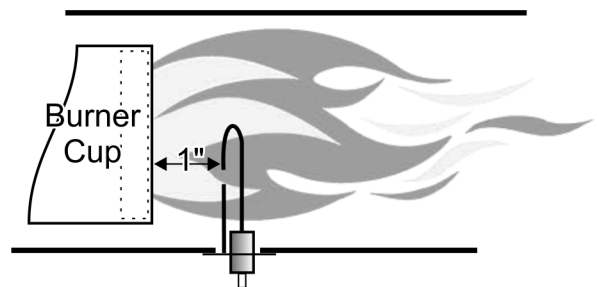

Electrodes should have a gap spacing of 3/16" (0.188" ± 0.031" or 4.76 mm ± 0.81 mm). If this spacing is not correct, the assembly must be adjusted or replaced. DO NOT adjust the curved igniter/sensor prong. Adjust/bend only the ground prong (also see next page).

## SPARK IGNITER SET UP

Use the following diagram to check the Igniter gap. If the gap is incorrect adjustments should be made to the **GROUND PRONG/PIN ONLY! DO NOT BEND THE IGNITER PRONG!!!!**

**USE THE BLACK BARS BELOW AS A GUIDE FOR ADJUSTMENT. USE THE BARS THAT COINCIDE WITH THE FORMAT & SIZE OF THIS PUBLICATION.**

IF this manual is in 8.5" x 11" "booklet" format (pages folded in half) then use these bars →

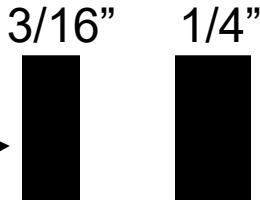

OR

IF this manual is printed 8.5" x 11" "full page" format use these bars →

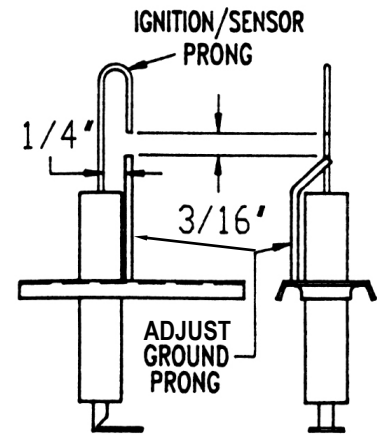
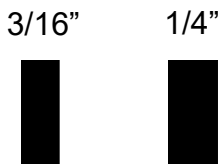

Multipurpose Meter: Use Microamp scale

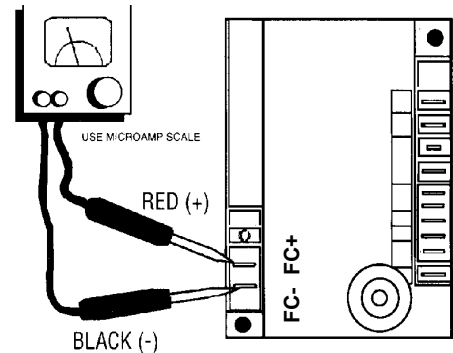

## SERVICE CHECKS

Flame current passes through the flame from the sensor to ground. The minimum flame current necessary to keep the system from lockout is 0.7 microamps. To measure flame current, connect an analog DC microammeter to the FC- FC+ terminals per figure at right.

Meter should read 0.7  $\mu$ A or higher. If the meter reads below "0" on scale, meter leads are reversed. Disconnect power and reconnect meter leads for proper polarity.

SYMPTOM	RECOMMENDED ACTION(S)
1. Dead	A. Miswired - check electrical supply (120Vac $\pm$ 5%) B. Transformer bad (24Vac $\pm$ 10%) C. Fuse/Circuit breaker bad D. Bad control (check LED for steady on)
2. Thermostat on - no blower output	A. Miswired B. Bad thermostat no voltage @ terminal W C. Bad control (check LED for steady on)
3. Pressure switch input OK, but no Trial -for-Ignition after purge delay	A. Miswired (check PSW terminal voltage: 24Vac $\pm$ 10%) B. Flame sense problem (existing flame: check LED - 2 flashes) C. Bad control (check line voltage between L1 & IND)
4. Valve on, no spark	A. Shorted electrode B. Open HV cable C. Bad control
5. Spark on, no valve	A. Valve coil open B. Open valve wire C. Bad control (check 24Vac voltage between V1 & V2)
6. Flame ok during TFI, no flame sense (after TFI)	A. Bad electrode B. Bad HV igniter wire C. Poor ground at burner D. Poor flame (check flame current)



## 20. TROUBLESHOOTING GUIDE - HEATER OPERATION



### WARNING

Improper adjustment, alteration, service or maintenance can cause property damage, injury or death. This heater must be installed and serviced only by a trained gas service technician

### SEQUENCE OF EVENTS (also see DSI Troubleshooting previous page)

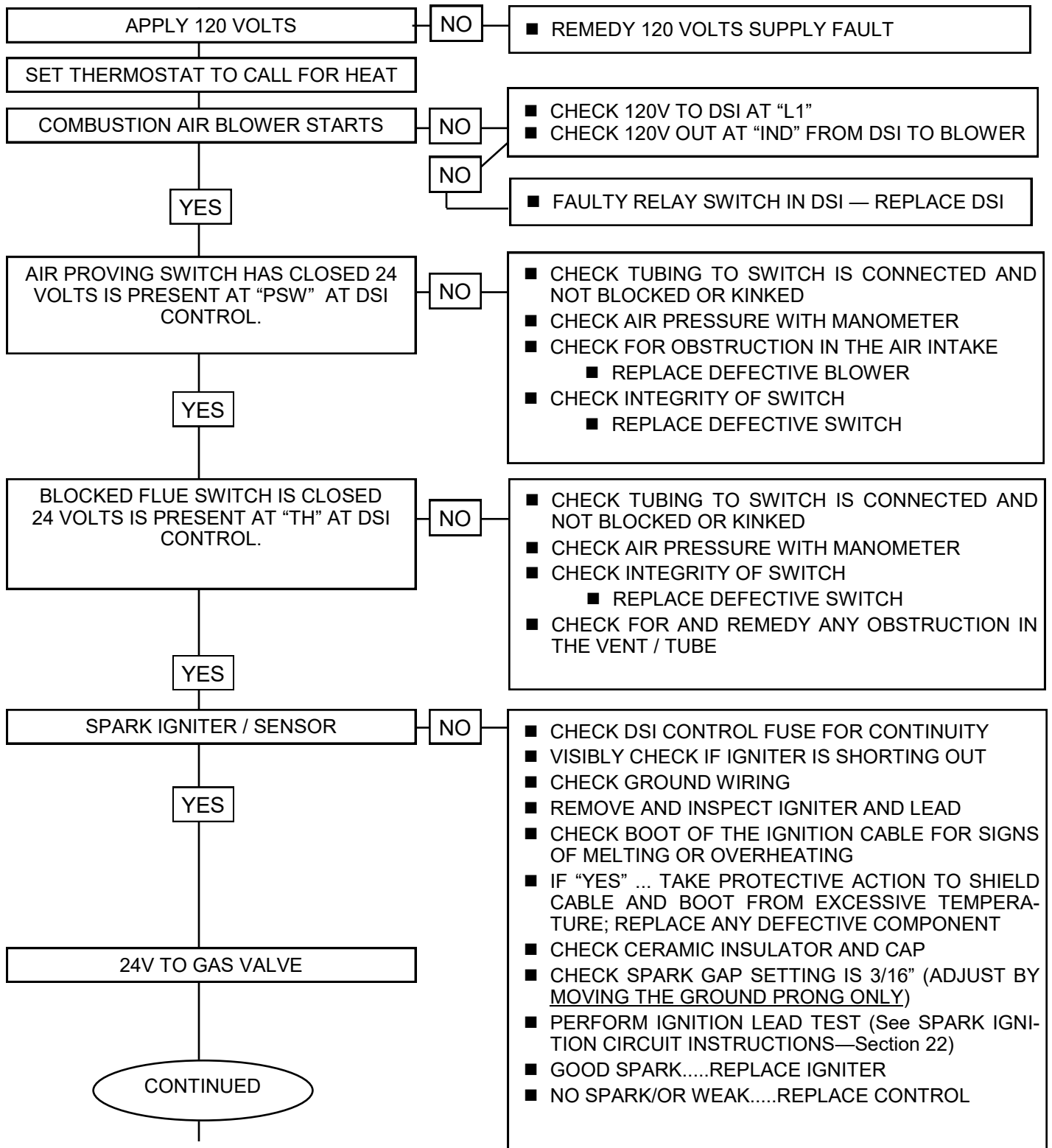

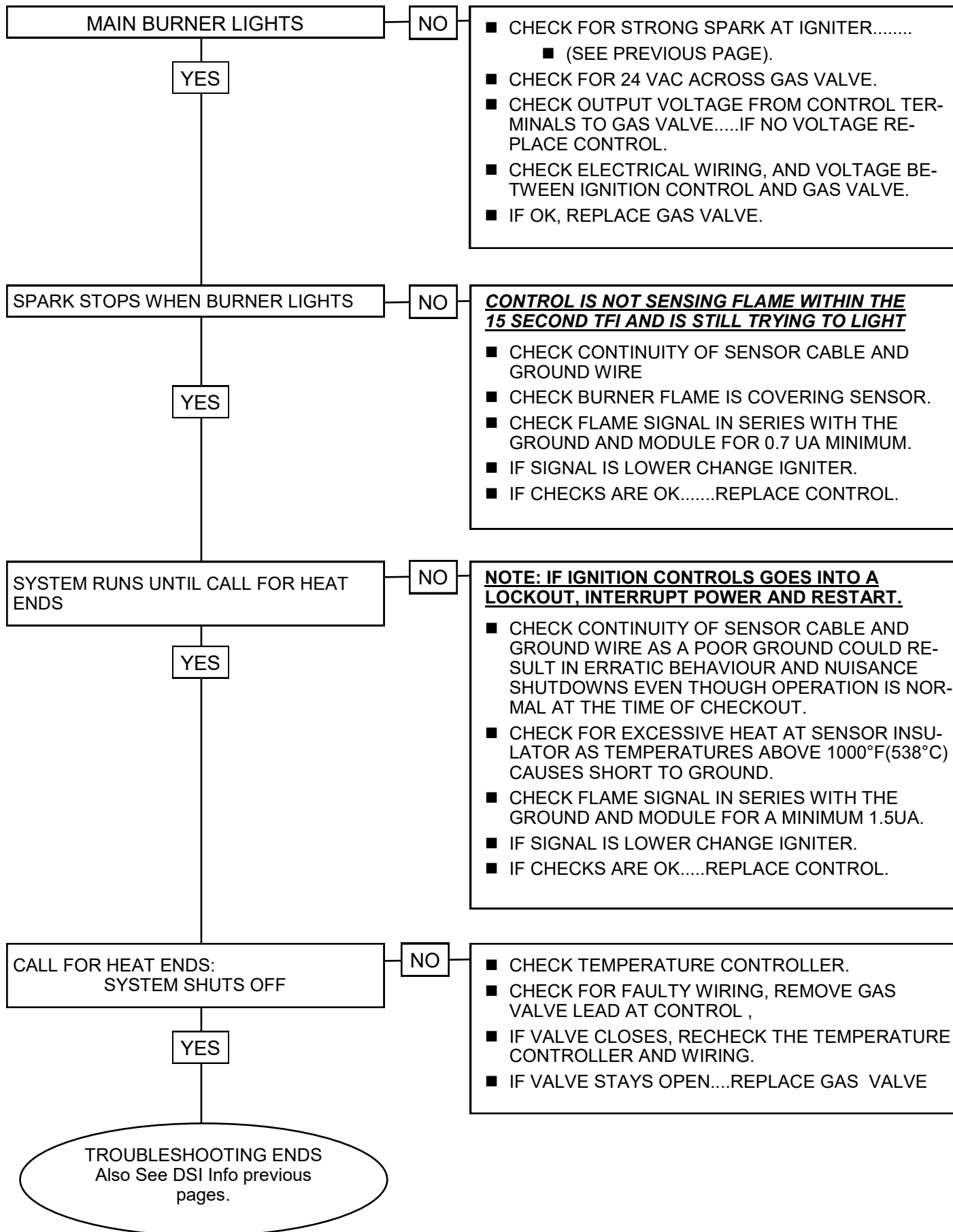

21. START-UP / COMMISSIONING SHEET



THIS EQUIPMENT HAS BEEN FACTORY FIRED AND TESTED PRIOR TO SHIPMENT. HOWEVER, THIS APPLIANCE IS NOT "PLUG & PLAY". IT REQUIRES COMMISSIONING AND FIELD ADJUSTMENT / SPECIFICATIONS CONFIRMATION TO ENSURE SAFE AND EFFICIENT OPERATION.

**COMMISSIONING REPORT  
AS PER I&O MANUAL AND LOCAL CODES**

CONTRACTOR NAME: .....DATE.....

ADDRESS:.....  
.....

CITY:.....

PHONE:.....

CELL: .....

JOB SITE.....CITY.....

HEATER MODEL NUMBER:.....

*Located on burner rating plate*

HEATER SERIAL NUMBER: .....

*Located on burner rating plate*

**TO ENSURE THAT SITE CONDITIONS ARE COMPATIBLE WITH THE HEATER'S PERFORMANCE AND TO ALLEVIATE NUISANCE CALL-BACKS, THE FOLLOWING START-UP NEEDS TO BE COMPLETED BY THE QUALIFIED GAS INSTALLER.**

**A TECHNICIAN CALLING FOR TECHNICAL SUPPORT MUST PROVIDE THE INFORMATION FROM THE COMPLETED COMMISSIONING REPORT ON THE NEXT PAGE**

**FAX COMPLETED REPORT TO TECHNICAL SERVICES:**

**FAX: 1-866-361-0523,  
PHONE: 1-877-686-3779**



**WARNING**

**START UP 'SMOKE'**

During start up, material coatings used in the production process of tubes and reflectors will "burn off" and create smoke during the first hour of operation. This is temporary and normal. Please ensure that there is sufficient ventilation to adequately clear the smoke from the space. Notify site and safety personnel to ensure that alarm systems are not unduly activated.

## QUALIFIED INSTALLER TO COMPLETE THIS TUBE HEATER COMMISSIONING REPORT

TYPE OF GAS:	NG	<input type="checkbox"/>	LP	<input type="checkbox"/>
DOES BUILDING HAVE A NEGATIVE CONDITION:	YES	<input type="checkbox"/>	NO	<input type="checkbox"/>
IF THIS IS A HIGH ALTITUDE AREA WHAT IS THE ALTITUDE ABOVE SEA LEVEL		<input type="text"/>		Ft
DOES APPLICATION REQUIRE FRESH AIR TO BURNER	YES	<input type="checkbox"/>	NO	<input type="checkbox"/>
IS HEATER EXPOSED TO CHEMICAL OR CORROSIVE ATMOSPHERE:	YES	<input type="checkbox"/>	NO	<input type="checkbox"/>
ARE ACTUAL MINIMUM CLEARANCES AS PER TABLE 3	YES	<input type="checkbox"/>	NO	<input type="checkbox"/>
CAN HEATER BE AFFECTED BY OVERHEAD CRANES / VIBRATION	YES	<input type="checkbox"/>	NO	<input type="checkbox"/>
ARE GAS SUPPLY LINES ADEQUATELY SIZED FOR SYSTEM	YES	<input type="checkbox"/>	NO	<input type="checkbox"/>
GAS LINES AND BRANCHES HAVE BEEN PURGED OF AIR:	YES	<input type="checkbox"/>	NO	<input type="checkbox"/>
THIS HEATER FIRED WITHOUT ANY MALFUNCTION:	YES	<input type="checkbox"/>	NO	<input type="checkbox"/>
INLET GAS SUPPLY PRESSURE WITH HEATER OPERATING :		<input type="text"/>		WC"
GAS VALVE OUTLET (Manifold) PRESSURE WITH HEATER OPERATING:		<input type="text"/>		WC"
WHAT IS THE LINE VOLTAGE READING AT THE HEATER		<input type="text"/>		VOLTS
WHAT IS THE VOLTAGE READING AT THE IGNITION MODULE		<input type="text"/>		VOLTS
WHAT IS THE FLAME SIGNAL STRENGTH IN uA FROM SENSOR:		<input type="text"/>		uA (microamps)
IS HEATER CONTROLLED BY A THERMOSTAT	YES	<input type="checkbox"/>	NO	<input type="checkbox"/>
IS THE THERMOSTAT STRATEGICALY LOCATED	YES	<input type="checkbox"/>	NO	<input type="checkbox"/>
WHAT IS TOTAL LENGTH OF INSTALLED THERMOSTAT WIRE		<input type="text"/>		FEET
WHAT IS THE GAUGE OF THE THERMOSTAT WIRE		<input type="text"/>		GAUGE
WHAT IS THE HEATER TUBE LENGTH (10ft per Tube section)		<input type="text"/>		FEET
WHAT IS THE TOTAL LENGTH OF THE VENT (add 10ft for each bend)		<input type="text"/>		FEET
WHAT LENGTH IS COMBUSTION AIR INTAKE (add 10ft for each bend)		<input type="text"/>		FEET
IF REQUIRED....WHAT IS THE LENGTH OF THE TURBULATOR(S)		<input type="text"/>		FEET
IF INSTALLED....IS TURBULATOR AT FLUE END OF SYSTEM	YES	<input type="checkbox"/>	NO	<input type="checkbox"/>
"MAXIMUM STACKING HEIGHT" SIGN(S) - POSTED AT THERMOSTAT(S)		<input type="checkbox"/>		

**THIS HEATER MUST BE ELECTRICALLY GOUNDED**

**FAX COMPLETED REPORT TO TECHNICAL SERVICES: FAX 1-866-361-0523, VOICE 1-877-446-3727**

## 22. BURNER & TUBE KIT ASSEMBLY CHART MODELS S100 / ITB

MODELS S100 & ITB are approved for indoor commercial / industrial non-residential applications. For outdoor, wet and harsh environment applications refer to models SPW-JZ / IWP (powder coated burner box) and/or STW-JZ / IW (stainless steel burner box).





**BEFORE INSTALLING: ENSURE you have the CORRECT TUBE KIT(s) for the BURNER INPUT**

		S100 / ITB - TUBE KIT PART # & QUANTITY REQUIRED								
		Stand-Alone Kits					Primary Kits		+ Secondary Kits	
		80	120	120	170	210	165	165	120	165
		10'	20'	20'	30'	40'	30'	30'	20'	30'
		TM-4510-SX	TM-1020-SX	TM-1420-SX	TM-1430-SX	TM-1040-SX	TM-F030-SX	TM-1030-SX	TM-0020-SX	TM-0030-SX
45,000	10'	1								
	20'			1						
60,000	20'			1						
	30'				1					
80,000	20'			1						
	30'				1					
	40'					1				
100,000	20'		1							
110,000	30'				1					
	40'					1				
	50'						1+		1	
130,000	30'				1					
	40'					1				
	50'						1+		1	
155,000	40'					1				
	50'						1+		1	
	60'						1+			1
175,000	50'							1+	1	
	60'							1+		1
	70'							1+	2	
200,000	50'							1+	1	
	60'							1+		1
	70'							1+	2	

**\*NOTE: S100 Series tubes are NOT emissive coated**  
*(except 10' x 45,000 & 20' x 100,000 Btuh tubes are emissive coated)*

- Stand-Alone tube kits require no additional tube kits.**
- Primary tube kits require at least one additional Secondary tube kit.**
- Secondary tube kit require a Primary tube kit.**

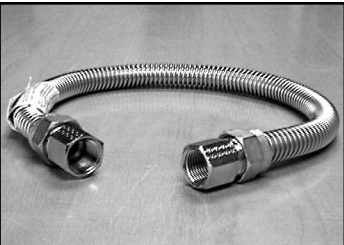
**FLEXIBLE GAS CONNECTOR (Included in Burner Kit) - MUST INSTALL - see Section 13**

<p><b><u>USA</u> - Stainless Steel Flexible Gas Connector</b></p> <p>125,000 or less: JL-0771-XX - 1/2"x24"</p> <p>150,000 or more: JL-0771-YY - 3/4"x36"</p>	<p><b><u>CANADA</u> - Type 1 Hose Gas Connector</b></p> <p>125,000 or less: JL-0771-RC - 1/2"x30"</p> <p>150,000 or more: JL-0771-RB - 3/4"x30"</p>
	

## 23. BURNER & TUBE KIT ASSEMBLY CHART MODELS S100U / ITBU

MODELS S100U & ITBU are approved for indoor commercial / industrial non-residential applications. For outdoor, wet and harsh environment applications refer to models SPW-JZ / IWP (powder coated burner box) and/or STW-JZ / IW (stainless steel burner box).



**BEFORE INSTALLING: ENSURE you have the CORRECT TUBE KIT(s) for the BURNER INPUT**

		S100U / ITBU - TUBE KIT PART # & QUANTITY REQUIRED					
		Stand-Alone **			Primary **		2ndary
		100	145	170	170	170	65
<i>Tube Kit Gross Weight (lbs) -&gt;</i>		10'	15'	20'	20'	20'	10'
<i>Side-by-Side Tubes Length -&gt;</i>		10'	15'	20'	20'	20'	10'
INPUT Btuh		TM-1410-SU	TM-1415-SU	TM-1020-SU	TM-0020-SU	TM-A120-SU	TM-0010-SU
60,000	2 x 10'	1					
80,000	2 x 10'	1					
	2 x 15'		1				
110,000	2 x 15'		1				
	2 x 20'			1			
130,000	2 x 15'		1				
	2 x 20'			1			
155,000	2 x 20'			1			
	2 x 30'				1+		1
175,000	2 x 30'					1+	1
200,000	2 x 30'					1+	1

*\*\* These kits include Turn Box JS-0513-BU packed and shipped in a separate carton*

**\*NOTE: S100U / ITBU series tubes are NOT emissive coated**  
**Stand-Alone tube kits require no additional tube kits.**  
**Primary tube kits require at least one additional Secondary tube kit.**  
**Secondary tube kit require a Primary tube kit.**

FLEXIBLE GAS CONNECTOR (Included in Burner Kit) - MUST INSTALL - see Section 13

**USA - Stainless Steel Flexible Gas Connector**

125,000 or less:  
 JL-0771-XX - 1/2"x24"

150,000 or more:  
 JL-0771-YY - 3/4"x36"

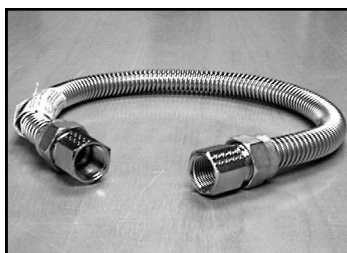

**CANADA - Type 1 Hose Gas Connector**

125,000 or less:  
 JL-0771-RC - 1/2"x30"

150,000 or more:  
 JL-0771-RB - 3/4"x30"



## 24. MODEL INPUT RATINGS (BTUH ) AND DIMENSIONS

MODEL	BTUH INPUT 0' to 4500' ABOVE SEA LEVEL	NOMINAL STRAIGHT TUBE LENGTH (ft)	OVERALL HEATER LENGTH STRAIGHT (ft)	NOMINAL 'U'- TUBE LENGTH (ft)	OVERALL HEATER LENGTH 'U'-TUBE (ft)	APPROX NET WEIGHT (LBS)
S100 / ITB 200	200,000	70	69' 8"			324
S100 / ITB 200	200,000	60	60'	30'U	31'-11"	282
S100 / ITB 200 NG ONLY	200,000	50	50' 4"			239
S100 / ITB 175 NG ONLY	175,000	70	69' 8"			324
S100 / ITB 175	175,000	60	60'	30'U	31'-11"	282
S100 / ITB 175	175,000	50	50' 4"			239
S100 / ITB 155	150,000	60	60'	30'U	31'-11"	282
S100 / ITB 155	150,000	50	50' 4"			239
S100 / ITB 155	150,000	40	40' 8"	20'U	22'-3"	197
S100 / ITB 130	125,000	50	50' 4"			239
S100 / ITB 130	125,000	40	40' 8"	20'U	22'-3"	197
S100 / ITB 130 NG ONLY	125,000	30	31'	15'U	17'-3"	154
S100 / ITB 110	110,000	50	50' 4"			239
S100 / ITB 110	110,000	40	40' 8"	20'U	22'-3"	197
S100 / ITB 110	110,000	30	31'	15'U	17'-3"	154
S100 / ITB 100 NG ONLY	100,000	20	21' 4"	-		111
S100 / ITB 80	80,000	40	40' 8"	20'U	22'-3"	197
S100 / ITB 80	80,000	30	31'	15'U	17'-3"	154
S100 / ITB 80	80,000	20	21' 4"	10'U	12'-7"	111
S100 / ITB 60	60,000	30	31'			154
S100 / ITB 60	60,000	20	21' 4"	10'U	12'-7"	111
S100 / ITB 45	45,000	20	21' 4"			111

See next page for dimensions of heater components (Burner, tube, reflector, turn box)

**FIGURE 24 HEATER DIMENSIONS**

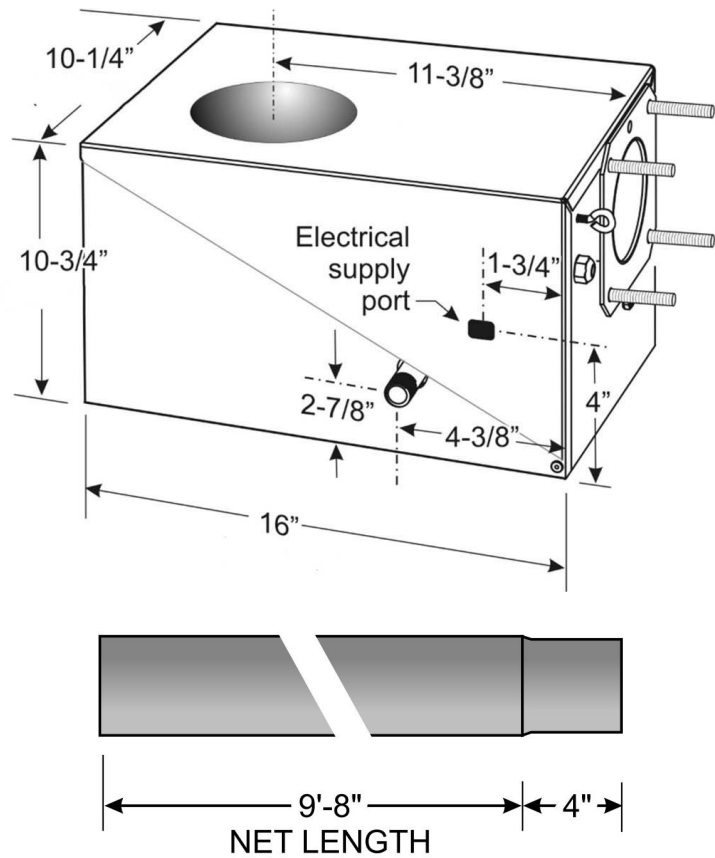

Reflector length: 120 inches

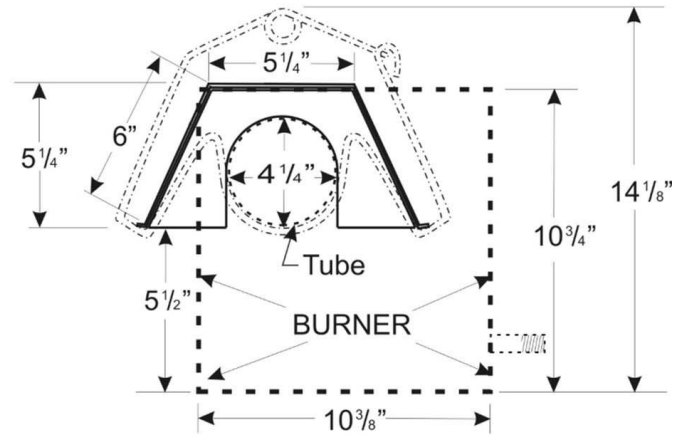

**TURN BOX FOR 'U'-TUBE**

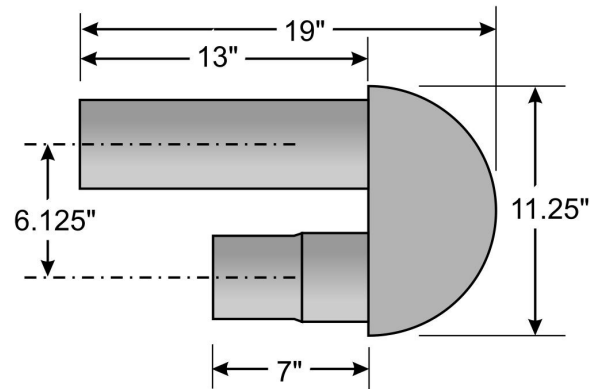

**FIGURE 25 HANGER SPACING / LENGTH - AIR INTAKE TO VENT END - STRAIGHT**

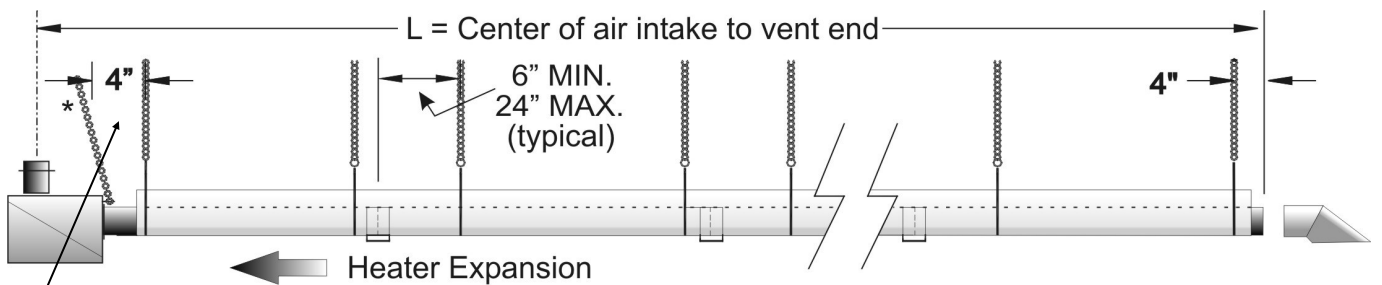

- POSITION BURNER END HANGER 4 INCHES (10 CM) FROM BURNER
- LOCATE SYSTEM HANGERS NO LESS THAN 6 INCHES (15 CM) AND NO MORE THAN 24 INCHES (61 CM) FROM TUBE COUPLING
- \* ANGLE BURNER SUPPORT CHAIN BACK OVER BURNER - ALLOWS TUBE SYSTEM EXPANSION

Tube Length	'L' = center air intake to end	Tube Length	'L' = center air intake to end
10'	11'-3 3/4" ; 135 3/4"	50'	49'-11 3/4" ; 599 3/4"
20'	20'-11 3/4" ; 251 3/4"	60'	59'-7 3/4" ; 715 3/4"
30'	30'-7 3/4" ; 367 3/4"	70'	69'-3 3/4" ; 831 3/4"
40'	40'-3 3/4" ; 483 3/4"		



## 25. TURBULATOR LENGTH & LOCATION IN SYSTEM: S100 / ITB - Straight Tube



**NOTE:** Improper location of a turbulator can cause malfunction of the heater, property damage, and will void the heater warranty.

Tubes with turbulators are clearly labeled for easy identification.

Refer to footnotes below the table.

### STRAIGHT TUBE SYSTEMS

### U-TUBE SYSTEMS

GAS TYPE	MODEL x Length (ft)	TURBULATOR LENGTH(S)	GAS TYPE	MODEL x Length (ft)	TURBULATOR LENGTH(S)
NG or Propane	45 x 20	39" + 96"	NG or Propane	60 x 10U	39" + 96"
NG or Propane	60 x 20	39" + 96"	NG or Propane	80 x 10U	39" + 96"
NG or Propane	60 x 30 <sup>1</sup>	96" <sup>1</sup>	NG or Propane	80 x 15U	96" <sup>1</sup>
NG or Propane	80 x 20	39" + 96"	NG or Propane	110 x 15U	60" + 96"
NG or Propane	80 x 30 <sup>1</sup>	96" <sup>1</sup>	NG or Propane	110 x 20U	24" + 96"
NG or Propane	80 x 40	24" + 109"	NG ONLY	130 x 15U	60" + 96"
NG ONLY	100 x 20	Stamped S/S	NG or Propane	130 x 20U	24" + 96"
NG or Propane	110 x 30	60" + 96"	NG or Propane	155 x 20U	24" + 96"
NG or Propane	110 x 40	24" + 109"	NG or Propane	155 x 30U	None
NG or Propane	110 x 50	24" (3rd Tube)	NG ONLY	175 x 30U	40" + 72"
NG ONLY	130 x 30	60" + 96"	NG or Propane	200 x 30U	40" + 72" <sup>3</sup>
NG or Propane	130 x 40	24" + 109"			
NG or Propane	130 x 50	24" (3rd Tube)			
NG or Propane	155 x 40	24" + 109"			
NG or Propane	155 x 50	24" (3rd Tube)			
NG or Propane	155 x 60	24" (3rd Tube)			
NG or Propane	175 x 50/60 <sup>2</sup>	40" + 72" <sup>2</sup>			
NG ONLY	175 x 70 <sup>2</sup>	40" + 72" <sup>2</sup>			
NG ONLY	200 x 50	40" + 72"			
NG or Propane	200 x 60/70 <sup>3</sup>	40" + 72" <sup>3</sup>			

**See next page for an illustration of turbulator length and location.**

- 60 / 80 x 30'**: Remove 5 ft section of turbulator from the aluminized steel tube (2nd tube in system); install tube with 96" turbulator at the vent end of the system
- 175 Propane x 60'**: Install tube with turbulators as **5th tube** in the system  
**175 NG x 60' & 70'**: Install tube with turbulators as **6th tube** in the system
- 200 x 60' & 70' & 30'U**: Remove 40" piece of turbulator from the upstream end of tube with turbulator, and install the tube with turbulator as the **6th tube** in the system

# TURBULATOR LENGTH & LOCATION IN SYSTEM:

## SINGLE STAGE

### MODEL x LENGTH:

### TUBE MATERIAL LEGEND:

A/S = ALUMINIZED STEEL  
 HRS = HOT ROLLED STEEL  
 S/S = STAINLESS STEEL

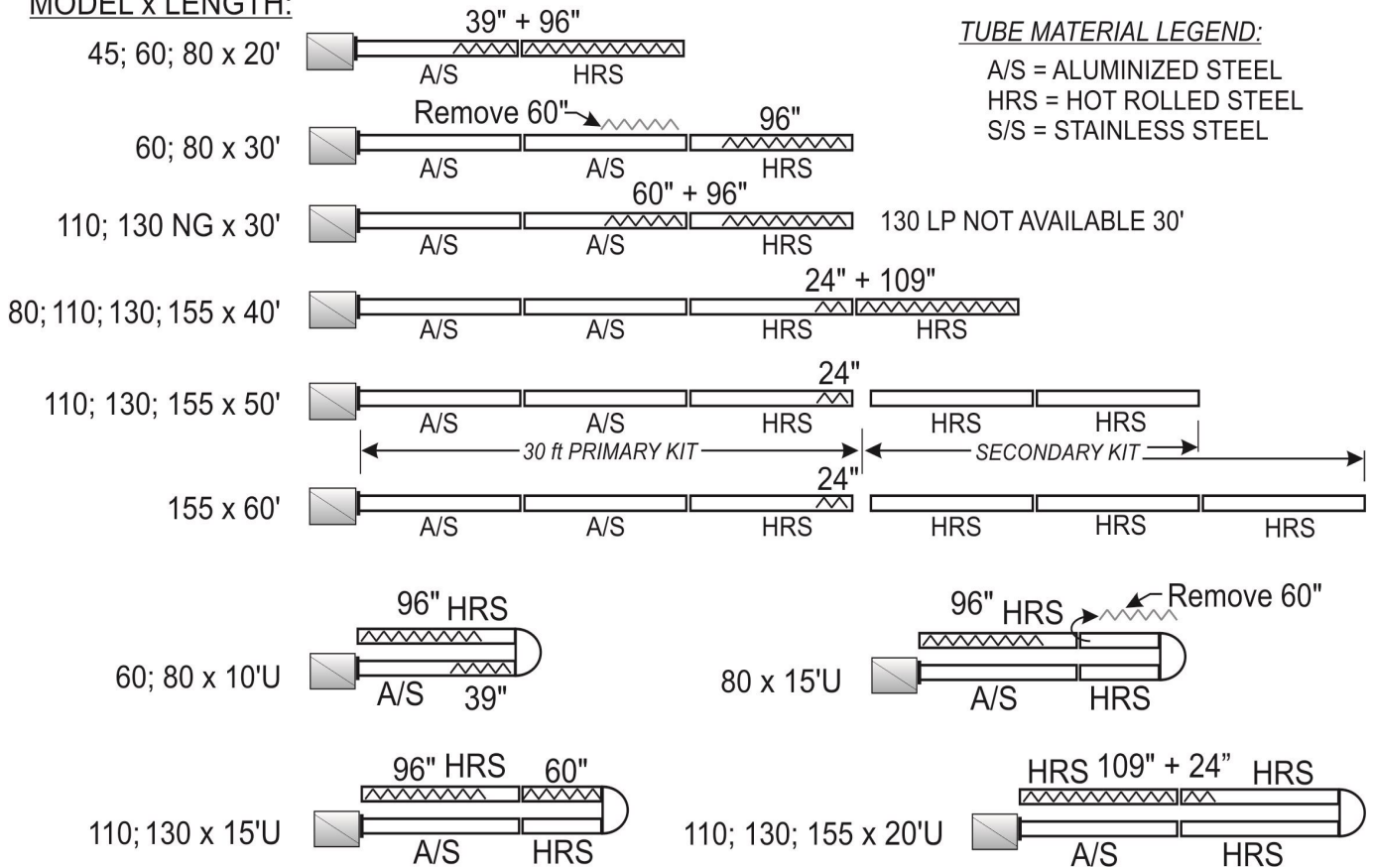

NOTE: FOR FOLLOWING MODELS THE TURBULATOR TUBE IS PACKAGED IN THE 30 FT PRIMARY TUBE KIT

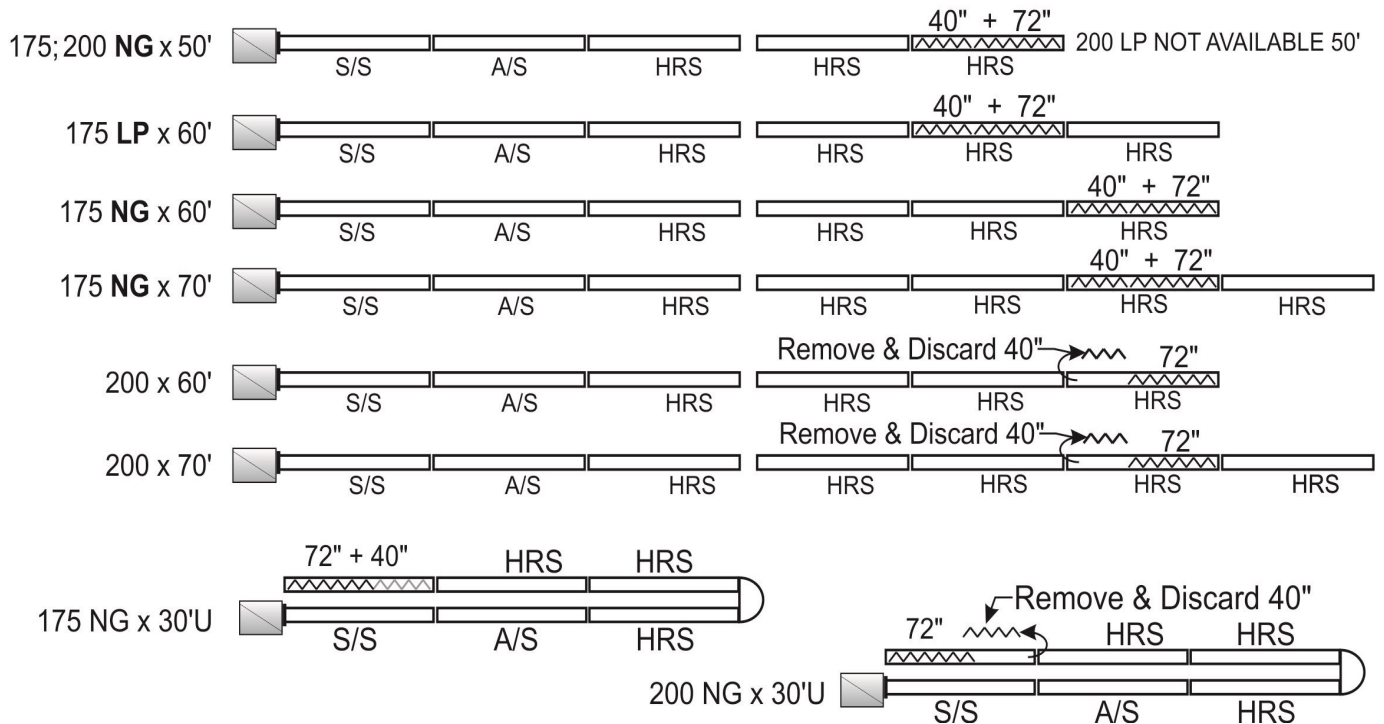

## 26. GAS CONVERSION OF BURNERS

Tube Heater Burners are factory produced and supplied to operate on natural gas.

100,000 Btuh input model is available in natural gas only and is not convertible to propane gas.

For models with inputs 60,000, 80,000, 110,000, 125,000, and 150,000 Btuh a field conversion kit is available to convert from natural gas to propane gas, or vice versa. Refer to the table below for kit part numbers. Each kit contains the specific instructions required to install the kit.

**Models with inputs 175,000 and 200,000 Btuh** are field convertible between gas types, but the conversion is relatively more extensive and expensive than lesser input models. When ordering, Model & Serial Numbers are required. For inputs 175,000 and 200,000 it is recommended that the burner be ordered and factory produced for the specific type of fuel gas using the following complete burner kit part numbers:

- Natural gas: 175,000 Btuh: JS-S175-AN (USA) or JS-S175-CN (Canada);
  - 200,000 Btuh: JS-S200-AN (USA) or JS-S200-CN (Canada)
- Propane gas: 175,000 Btuh: JS-S175-AL (USA) or JS-S175-CL (Canada);
  - 200,000 Btuh: JS-S200-AL (USA) or JS-S200-CL (Canada)
- The natural gas 175,000 burner can be connected to a 50, 60, or 70 foot tube system.
- The propane gas 175,000 burner can be connected only to a 50 or 60 foot tube system.
- The natural gas 200,000 burner can be connected to a 50, 60, or 70 foot tube system.
- The propane gas 200,000 burner can be connected only to a 60 or 70 foot tube system.

<b>Gas Conversion Kits - Order by Part Number:</b>		
<b>Input Rate (Btuh)</b>	<b>Conversion Kit NG to Propane</b>	<b>Conversion Kit Propane to NG</b>
<b>45,000</b>	JS-0556-XC	JS-0556-XD
<b>60,000</b>	JS-0557-XX	JS-0558-XX
<b>80,000</b>	JS-0559-XX	JS-0560-XX
<b>100,000</b>	NG Only - Not convertible	
<b>110,000</b>	<i>Check with factory: Provide Model &amp; Serial #'s</i>	
<b>130,000</b>	<i>Check with factory: Provide Model &amp; Serial #'s</i> <i>NOTE: 30 ft heater is NG ONLY</i>	
<b>150,000</b>	JS-0565-XX	JS-0566-XX
<b>175,000</b>	Order new burners for specific fuel type <i>Check with factory: Provide Model &amp; Serial #'s</i>	
<b>200,000</b>	Order new burners for specific fuel type <i>Check with factory: Provide Model &amp; Serial #'s</i>	

## 27. HIGH ALTITUDE INSTALLATION

**Canada:** Heaters can be installed to an altitude of 4500 ft without revision.

- To install above 4500 feet refer to recommendation of local authority having jurisdiction.

**USA:** The factory installed orifice is approved for normal altitude up to 2000 ft.

When this appliance is installed above an altitude of 2000 feet in the USA , the input must be de-rated by 4% for each 1000 ft . Refer to the table next page for orifice sizing and restrictions that apply to high altitude installation. Check with your local authority regarding de-rating.

**NOTE: Installations above 4,500 ft: Restrict the Total Combined System Length as indicated in the TOTAL SYSTEM LENGTH RESTRICTIONS Table below.**

**MINIMUM VENT LENGTH:** Vented or Unvented (indirect mechanical ventilation))

- Minimum vent length of 3 ft is required (**NOTE:** 200,000 Propane: Minimum 8 ft.

**HIGH ALTITUDE MAXIMUM SYSTEM LENGTH (above 4,500 ft) :**

**includes: Tube Heater length + combustion air duct + vent:**

- Each 90° elbow in the system has an equivalent length of 5 ft.
- A maximum of 2 elbows are allowed in any portion (duct, tube heater, vent) with the exception of up to three 90° elbows in a vertical vent run through the roof
- Combustion air duct may be 4" or 5" diameter and is not to exceed lengths in table below
- Exceeding the allowable lengths in the table below can create combustion and/or condensation problems and will void CSA Certification and the heater warranty.
- Do not exceed the **Maximum Combined System Length** regardless of the allowed maximum length of individual vent or combustion air duct

### TOTAL SYSTEM LENGTH RESTRICTIONS: INSTALLATIONS ABOVE 4,500 FEET (*Lower altitudes refer to Section 12A*)

Input (Btuh)	Do Not Exceed Maximum Combined System Length		Max. Air Duct Length (ft) (by Duct Diameter)		Max. Vent Length (ft) Individual: 4"Ø Combined: 6"Ø	Example
	4" Air Duct	5" Air Duct	4" Ø	5" Ø		
45,000 & 60,000	40 ft	60 ft	20 ft	40 ft	20 ft	150,000 Btuh Heater: Tube Heater Length 40 ft 1 x 90° elbow (vent) 5 ft Straight vent 15 ft
80,000	50 ft	70 ft	20 ft	40 ft	20 ft	1 x 90° elbow (duct) 5 ft
100,000	40 ft	60 ft	30 ft	50 ft	30 ft	Air Duct: 4" Ø <u>13 ft</u> Combined Length 78 ft
110,000 to 155,000	80 ft	100 ft	30 ft	50 ft	30 ft	Max. Allowed 80 ft
175,000 & 200,000	-	120 ft	Use 5"Ø	50 ft	40 ft	Additional 20' for 5" Ø Air Duct



## 27. HIGH ALTITUDE INSTALLATION *continued*

### ORIFICE CHART - ALTITUDE CONVERSION

~ SEE NOTES ON PREVIOUS PAGE ~

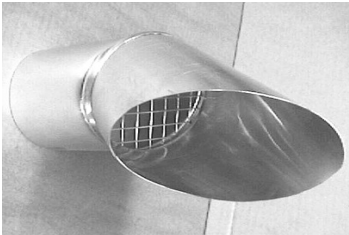

MODEL NO	FOR USE AT ALTITUDES ABOVE (FEET) Gas Orifice Drill Size / Part#							
	Supplied	USA						
	0	2000	3000	4000	5000	6000	7000	8000
<b>S100 / ITB-45 NG</b>	30 DMS JS-0730-DM	30 DMS JS-0730-DM	30DMS JS-0730-DM	30DMS JS-0730-DM	30DMS JS-0730-DM	30DMS JS-0730-DM	31DMS JS-0731-DM	31DMS JS-0731-DM
<b>S100 / ITB-45 Propane</b>	46 DMS JS-0746-DM	46 DMS JS-0746-DM	46 DMS JS-0746-DM	48 DMS JS-0748-DM	48 DMS JS-0748-DM	48 DMS JS-0748-DM	49 DMS JS-0749-DM	49 DMS JS-0749-DM
<b>S100 / ITB-60 NG</b>	24 DMS JS-0724-DM	26 DMS JS-0726-DM	27 DMS JS-0727-DM	27 DMS JS-0727-DM	28 DMS JS-0728-DM	28 DMS JS-0728-DM	29 DMS JS-0729-DM	29 DMS JS-0729-DM
<b>S100 / ITB-60 Propane</b>	42 DMS JS-0742-DM	42 DMS JS-0742-DM	43 DMS JS-0743-DM	43 DMS JS-0743-DM	43 DMS JS-0743-DM	44 DMS JS-0744-DM	44 DMS JS-0744-DM	45 DMS JS-0745-DM
<b>S100 / ITB-80 NG</b>	17 DMS JS-0717-DM	19 DMS JS-0719-DM	19 DMS JS-0719-DM	20 DMS JS-0720-DM	21 DMS JS-0721-DM	22 DMS JS-0722-DM	23 DMS JS-0723-DM	24 DMS JS-0724-DM
<b>S100 / ITB-80 Propane</b>	36 DMS JS-0736-DM	38 DMS JS-0738-DM	39 DMS JS-0739-DM	39 DMS JS-0739-DM	40 DMS JS-0740-DM	41 DMS JS-0741-DM	42 DMS JS-0742-DM	42 DMS JS-0742-DM
<b>S100 / ITB-100 NG</b>	5.2 mm JS-0752-MM	5.1 mm JS-0751-MM	5.0 mm JS-0750-MM	9 DMS JS-0709-DM	11 DMS JS-0711-DM	0.19 i N JS-0719-IN	13 DMS JS-0713-DM	14 DMS JS-0714-DM
<b>S100 / ITB-110 NG</b>	5.2 mm JS-0752-MM	5.1 mm JS-0751-MM	5.0 mm JS-0750-MM	9 DMS JS-0709-DM	11 DMS JS-0711-DM	0.19 i N JS-0719-IN	13 DMS JS-0713-DM	14 DMS JS-0714-DM
<b>S100 / ITB-110 Propane</b>	31 DMS JS-0731-DM	32 DMS JS-0732-DM	32 DMS JS-0732-DM	32 DMS JS-0732-DM	33 DMS JS-0733-DM	34 DMS JS-0734-DM	35 DMS JS-0735-DM	36 DMS JS-0736-DM
<b>S100 / ITB-130 NG</b>	5.8 mm JS-0758-MM	5.7 mm JS-0757-MM	5.6 mm JS-0756-MM	5.5 mm JS-0755-MM	3 DMS JS-0703-DM	4 DMS JS-0704-DM	5 DMS JS-0705-DM	0.20 in JS-0720-IN
<b>S100 / ITB-130 Propane 30 FT IS NG ONLY</b>	29 DMS JS-0729-DM	29 DMS JS-0729-DM	30 DMS JS-0730-DM	30 DMS JS-0730-DM	30 DMS JS-0730-DM	1/8" JS-0713-IN	31 DMS JS-0731-DM	31 DMS JS-0731-DM
<b>S100 / ITB-155 NG</b>	0.25 in JS-0725-IN	6.4 mm JS-0764-MM	6.3 mm JS-0763-MM	6.2 mm JS-0762-MM	6.1 mm JS-0761-MM	6.0 mm JS-0760-MM	5.9 mm JS-0759-MM	5.8 mm JS-0758-MM
<b>S100 / ITB-155 Propane</b>	0.14 in JS-0714-IN	3.5 mm JS-0735-MM	29 DMS JS-0729-DM	3.4 mm JS-0734-MM	3.3 MM JS-0733-MM	3.3 MM JS-0733-MM	30 DMS JS-0730-DM	0.13 in JS-0713-IN
<b>S100 / ITB-175 NG</b>	6.7 mm JS-0767-MM	6.6 mm JS-0766-MM	6.6 mm JS-0766-MM	6.5 mm JS-0765-MM	6.5 mm JS-0765-MM	6.4 mm JS-0764-MM	6.3 mm JS-0763-MM	6.3 mm JS-0763-MM
<b>S100 / ITB-175 Propane</b>	24 DMS JS-0724-DM	25 DMS JS-0725-DM	26 DMS JS-0726-DM	27 DMS JS-0727-DM	28 DMS JS-0728-DM	28 DMS JS-0728-DM	29 DMS JS-0729-DM	29 DMS JS-0729-DM
<b>S100 / ITB-200 NG</b>	0.30 in JS-0730-IN	7.4 mm JS-0774-MM	7.3 mm JS-0773-MM	7.3 mm JS-0773-MM	7.2 mm JS-0772-MM	0.28 in JS-0728-IN	7.1 mm JS-0771-MM	7.0 mm JS-0770-MM
<b>S100 / ITB-200 Propane</b>	19 DMS JS-0719-DM	20 DMS JS-0720-DM	20 DMS JS-0720-DM	21 DMS JS-0721-DM	22 DMS JS-0722-DM	23 DMS JS-0723-DM	25 DMS JS-0725-DM	26 DMS JS-0726-DM

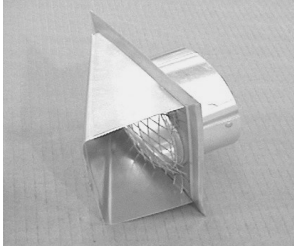
## 28. OPTIONAL ACCESSORIES

<p><b>#2 Lion Chain</b> (115 lb work load) - 200 ft roll</p> <p><b>Safety Snap Hooks</b> - 2" - package 25 - package 100</p>	<p>JL-0800-XX</p> <p>JL-0800-SH JL-0800-SH-B</p>	
<p><b>Flue Vent Terminal</b></p> <p>4" wall horizontal</p>	<p>JA-0528-XX</p>	
<p><b>Torctite Coupler</b></p> <p>Sufficient quantity supplied with heater Use for connection of vent tee, or replacement part</p>	<p>JA-0516-SW</p>	
<p><b>Vent Tee</b> 4" X 4" X 6" (Couplers optional - see above)</p>	<p>JA- 0514-XX</p>	
<p><b>Combustion Air Intake Cap—Wall</b></p>	<p>JS-0532-VC</p>	
<p><b>Clearance Sign</b> - <u>Required in some jurisdictions:</u></p> <ul style="list-style-type: none"> <li>• Vehicle service garages</li> <li>• 3/4" high red lettering on white background</li> </ul>	<p>JL-0798-CS</p>	<p style="text-align: center;"><b><u>WARNING</u></b></p> <p style="text-align: center;"><b>MAINTAIN ___" CLEARANCE FROM TUBE HEATER TO VEHICLES AND COMBUSTIBLE MATERIALS</b></p>



**Options For 24V Thermostat Control:**

**NOTE: Fenwal DSI has an onboard relay switch to control the blower motor (120 Vac) and allows for heater control with either 24V or 120V thermostat. The Fenwal DSI has a post-purge feature. A 24V Thermostat MUST be used to enable the post-purge feature. A line voltage thermostat will disable the post-purge feature**

<p><b>TruTemp Thermostat (24Vac - 3-Wire)</b>                  True comfort control for radiant heating systems - senses and averages ambient and radiant temperatures.                  Occupancy sensor with auto set-back of 9°F (5°C).  <i>Do not use in wet or corrosive environments</i></p>	<p>JM-0150-XX</p>	
<p><b>Low Voltage Digital Thermostat</b>                  (24 Volts - °F or °C selectable)  <i>Not for use in corrosive or wet environments</i></p>	<p>JS-0569-WR</p>	
<p><b>Multiple Heaters</b> per 24V Thermostat  <b>Relay Switch:</b> One required for each burner after the first burner in a zone (1st burner connects to 24V thermostat)                  Refer to wiring diagram Page 36 (field installed at or in burner)                  NOTE: FENWAL DSI has built in relay for blower operation</p>	<p>JS-0568-CC</p>	

**Line Voltage Control: (Disables post-purge feature of the Fenwal ignition control)**

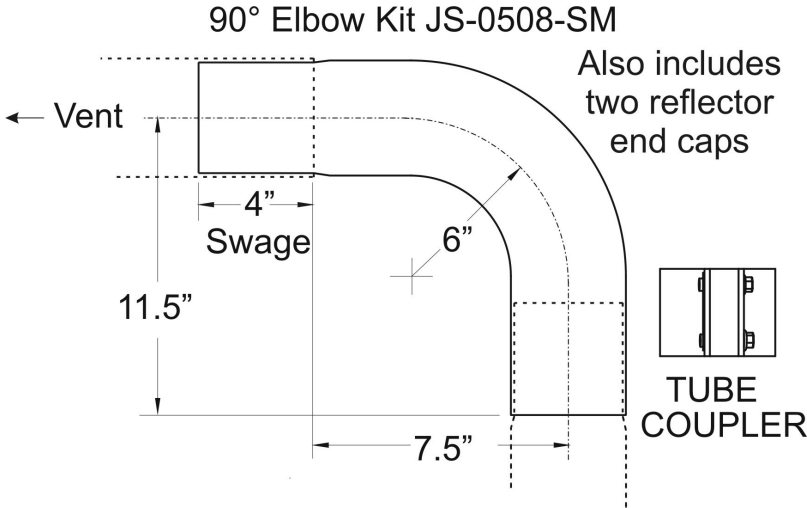
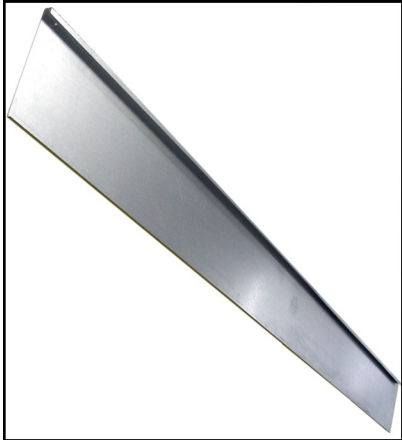
<p><b>Line Voltage Thermostat:</b>                  Dual Scale: °F or °C  <i>Not for use in corrosive or wet environments</i></p>	<p>JL-0772-XX</p>	
---	-------------------	---

<p><b>90 degree Aluminized Steel Elbow Kit</b></p> <p>(Kit includes: aluminized steel elbow, coupler, and two end plate hangers)</p> <p>For 180° elbow use two x JS-0508-SM, or use Model S100U / ITBU</p>	<p>JS-0508-SM</p>	
		<p>90° Elbow Kit JS-0508-SM</p> <p>Also includes two reflector end caps</p> 
<p><b>Side Reflector Extension Kit-</b> 10" deep, 10 ft long Each</p>	<p>JS-0509-KT</p>	
<p><b>Tube Protection Screen</b> -5 foot lengths</p>	<p>JA-0780-XS <i>For Builder Model</i></p>	





#	PART DESCRIPTION	MODEL	MODEL DASH #/ GAS TYPE	PART #	PART DESCRIPTION PRIMARY
7	BLOCKED FLUE PRESSURE SWITCH	45	-C; -UH	JS-0577-ZZ	Blocked flue switch 1.41" WC
		60	NG	JS-0577-SS	Blocked flue switch 0.58" WC
		80-130	NG	JS-0577-YY	Blocked flue switch 0.90" WC
		45	-X1	JS-0577-YY	Blocked flue switch 0.90" WC
		100	-X1;NG	JS-0577-ZZ	Blocked flue switch 1.41" WC
		60,80,110	-FB	JS-0578-UL	Blocked flue switch 1.03" WC
		110	-FB; LP	JS-0577-XY	Blocked flue switch 1.20" WC
		130	-FB	JS-0577-XZ	Blocked flue switch 1.25" WC
		155	-A.-F;NG	JS-0577-YY	Blocked flue switch 0.90" WC
		175	-S;NG	JS-0577-ZZ	Blocked flue switch 1.41" WC
		175	-S;LP	JS-0577-XY	Blocked flue switch 1.20" WC
		200	-S;LP	JS-0577-UW	Blocked flue switch 1.33" WC
200	-S;NG	JS-0578-BB	Blocked flue switch 1.50" WC		
8	BURNER CHAMBER	ALL		JS-0504-XX	Burner Chamber
9	BURNER AIR RESTRICTOR	45	NG	JS-0592-AR	Burner air restrictor (45 Only)
10	4" NIPPLE	ALL		JS-0590-XX	Nipple 1/2" x 4"
11	90 DEGREE ELBOW FITTING 1/2"	ALL		JS-0588-XX	Street elbow fitting 90 deg 1/2"X1/2"
12	EQUALIZER PLATE	45	NG	JS-0593-NG	Outlet equalizer plate 45 NG - 25 Holes
		60 to 155	NG & LP	JS-0593-XX	Outlet equalizer plate 60 to 155 LP & NG
		175	LP	JS-0593-XY	Outlet equalizer plate 175-S LP
		175	NG	JS-0593-XX	Outlet equalizer plate 175 NG
		200	NG & LP	JS-0593-YE	Outlet equalizer plate 200-S LP & NG
13	BLOWER GASKET	ALL	<i>Each</i>	JS-0578-XX	Outlet blower gasket
14	BLOWER ASSEMBLY	45 to 175		JS-0579-AA	Blower Assembly 1/35 HP - 45 to 175
		200		JS-0579-ZZ	Blower Assembly 1/20 HP - 200,000
15	GAS VALVE	45 to 155	NG	JL-0701-AA	Valve gas comb 3.5" WC 24VAC VR8 NG
		110	LP	JL-0703-AA	Valve gas comb 10" WC 24VAC VR8 LP
		175, 200	NG	JA-0506-XX	Gas Valve - Slow Open 3.5" WC NG
		175, 200	LP	JA-0507-XX	Gas Valve - Slow Open 10" WC LP
16	MANIFOLD BUSHING	ALL		JS-0589-XX	Manifold bushing 3/8" to 1/2"
17	AIR INLET C/W SCREEN	45	NG	JS-0595-SC	Air Inlet Adapter 45 NG , 1-1/2" Hole
		60	NG	JS-0594-ST	Air Inlet Adapter 60 NG & LP
		80	NG	JS-0595-SP	Air Inlet Adapter 80 NG & LP
		100	NG	JS-0595-UG	Air Inlet Adapter 100NG
		110	NG	JS-0595-AE	Air Inlet Adapter 110-200 NG & LP
		110	LP	JS-0595-AA	Air Inlet Adapter 110 LP
		130 to 200	NG & LP	JS-0595-AA	Air Inlet Adapter 110-200 NG & LP
18	MAIN BURNER ORIFICE	45	NG	JS-0730-DM	Gas orifice low intensity HR 30 DMS
		60	NG	JS-0724-DM	Gas orifice low intensity HTR 24 DMS
		80	NG	JS-0717-DM	Gas orifice low intensity HTR 17 DMS
		100	NG	JS-0752-MM	Gas orifice low intensity HTR 5.2 mm

continued ...

#	PART DESCRIPTION	MODEL	MODEL DASH #/ GAS TYPE	PART #	PART DESCRIPTION PRIMARY
18	MAIN BURNER ORIFICE	110	LP	JS-0731-DM	Gas orifice low intensity HTR 31 DMS
		110	NG	JS-0752-MM	Gas orifice low intensity HTR 5.2 mm
		130	NG	JS-0758-MM	Gas orifice low intensity HTR 5.8 mm
		155	NG	JS-0725-IN	Gas orifice low intensity HTR 1/4 inch
		175	LP	JS-0724-DM	Gas orifice low intensity HTR 24 DMS
		175	NG	JS-0767-MM	Gas orifice low intensity HTR 6.7 mm
		200	LP	JS-0719-DM-S	Gas orifice low intensity HTR 19 DMS
		200	NG	JS-0750-IN	Gas orifice low intensity HTR 5/16 inch
19	BURNER CUP	45	NG	JS-0510-LP-45	Burner Cup w/ Center Hole
		60-100	NG; LP	JS-0510-LP	Burner Cup
		110-155	NG; LP	JS-0512-XX	Burner Cup
		175	NG	JS-0512-XX	Burner Cup
		175	LP	JS-0512-UL	Burner Cup - Cast Aluminum - No Hole
		200	NG; LP	JS-0512-UL	Burner Cup - Cast Aluminum - No Hole
20	EYE BOLT	ALL		JF-1012-EB	Eye Bolt
21	BURNER CUP AIR RESTRICTOR RING	45	NG	JS-0596-AA	Burner Cup air restr ring 9/32"
		60-175	NG	JS-0596-XX	Burner Cup air rest ring 0.375
		110	LP	JS-0597-XX	Burner head air rest. ring .500
		175	-S; LP	JS-0597-XY	Burner Cup air rest ring 175-S LP
		200	-S; LP	JS-0597-YE	Burner Cup air rest ring 200-S LP
		200	-S; NG	JS-0597-YY	Burner Cup air rest ring 200-S NG
22	GROMMET	ALL		JP-2033-XX	Grommet - Strain Relief
23	FLAME RECTIFICATION PLATE	175	-S LP	JS-0591-XY	Flame Rectifier Plate 175-S LP
24	FLAME RECTIFICATION	60		JS-0592-RR	Flame Rectifier 40 -R
		110	-FB	JS-0592-RT	Flame Rectifier 110, 130 -FB Models
		130	-FB	JS-0592-RT	Flame Rectifier Plate 175-S LP
		200	-S LP	JS-0592-RZ	Flame Rectifier 200-S LP
25	PRESSURE SWITCH TUBING	ALL		JS-0572-SG	Tubing set 1/4" x 20" PVC
26	IGNITER KIT	ALL		JA-0571-KT	Igniter & gasket kit / DSI tube heater
27	FLANGE GASKET	ALL		JS-0591-XX	Gasket For Flange Adaptor

# S100 / ITB TUBE SYSTEM PARTS

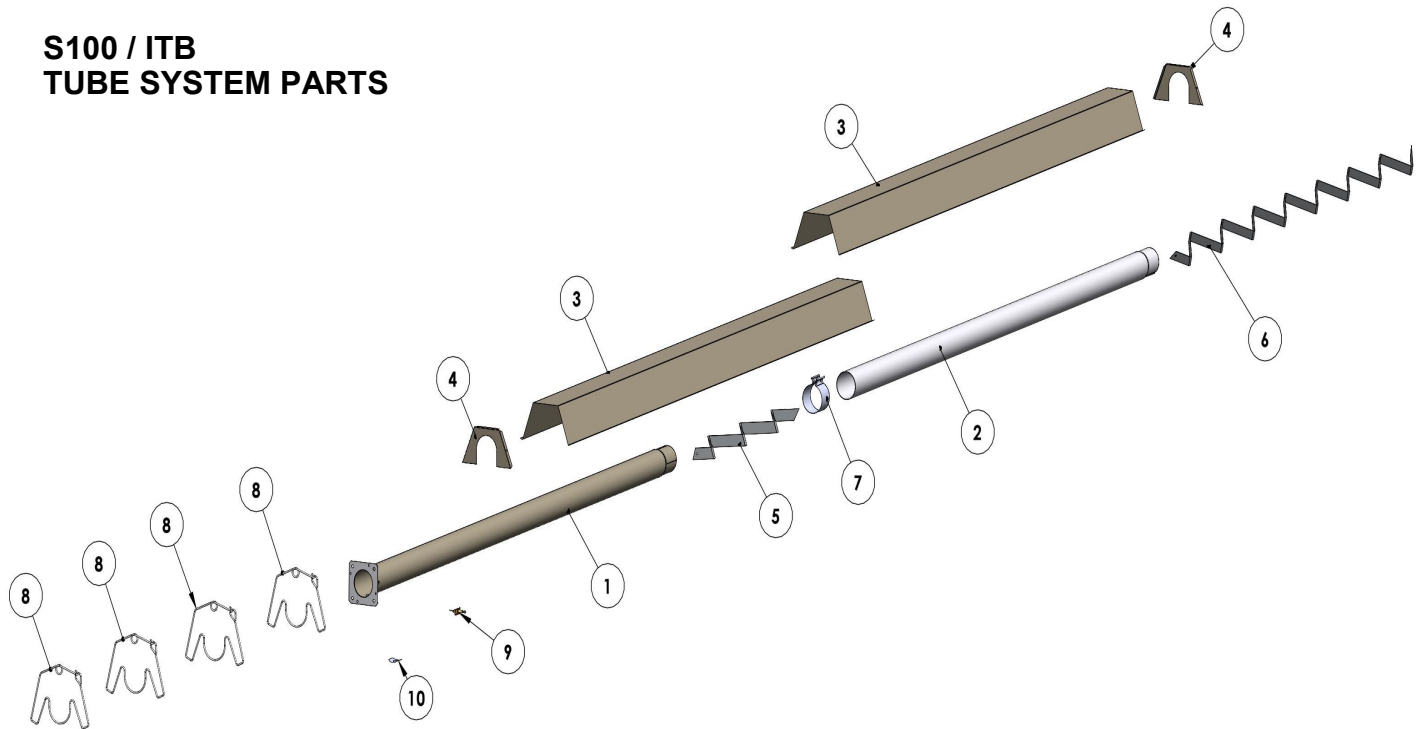

#	PART DESCRIPTION	MODEL	MODEL DASH #/ GAS TYPE	PART #	PART DESCRIPTION PRIMARY
1	FLANGED TUBES	45 to 155		JS-0501-SW-P	Flanged, Aluminized Steel tube, swaged, ports
		45 x 10FT, 100 x 20FT		JS-0501-PA-P	Aluminized Steel Flanged tube, swaged, painted
		175 & 200		JS-0500-SS-P	Flanged, Stainless Steel tube, swaged, ports; replaces JS-0499-SW-P
2	SWAGED TUBES - NO FLANGE	60 to 200 x 30FT & Above		JS-0501-SW	Aluminized tube, 10' with hole for rivet
		ALL		JS-0515-SW	Steel tube 10' swaged
3	REFLECTOR	ALL		JS-0502-EM	Reflector (18" x 120")
4	END CAP	ALL		JS-0502-ES	S100 / ITB series reflector end cap
5-6	TURBULATOR (see Table 4 in Manual)			JS-0533-UA	Turbulator 24" x 1.25" - Aluminized
				JS-0533-SK	Turbulator 39" x 2" - Stainless Steel
				JS-0533-SH	Turbulator 40" x 1.25" - Aluminized
				JS-0533-SS	Turbulator 60" x 1.25" - Stainless Steel
				JS-0533-UG	Turbulator 72" x 1.25" - Aluminized
				JS-0533-SL	Turbulator 96" x 2" - Stainless Steel
				JS-0533-LG	Turbulator 109" x 1.25" - Aluminized
		100 x 20FT		JS-0535-XX	Turbulator 10' Special - 100,000 Btuh ONLY
7	COUPLER	ALL		JA-0516-SW	4" swaged tube coupler torctite
		175 & 200	1st to 2nd tube connections	JA-0516-RK	Tube Connection Kit: Coupler + Rivet + Drill Bit
8	WIRE HANGER	ALL		JS-0505-EH	Small wire hanger
9	IGNITER KIT	ALL		JA-0571-KT	Igniter & gasket kit / DSI tube heater
10	SIGHTGLASS ASSEMBLY	ALL		JS-0536-XX	Sight glass assembly tube heater

continued ...

# S100U / ITBU TUBE SYSTEM PARTS

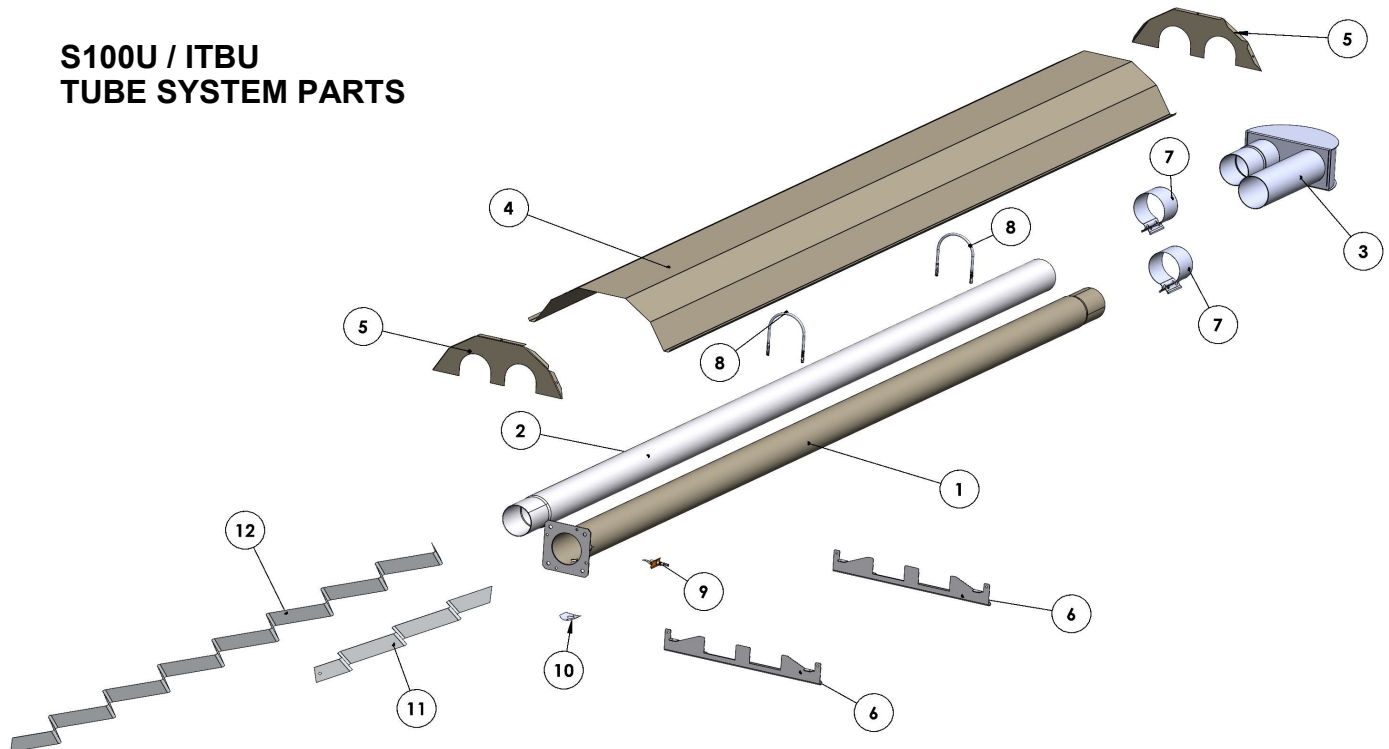

#	PART DESCRIPTION	MODEL	MODEL DASH #/ GAS TYPE	PART #	PART DESCRIPTION PRIMARY
1	FLANGED TUBES	45 to 155		JS-0501-SW-P	Flanged, Aluminized Steel tube, swaged, ports
		175 & 200		JS-0500-SS-P	Flanged, Stainless Steel tube, swaged, ports; replaces JS-0499-SW-P
2	SWAGED TUBES - NO FLANGE	175 & 200		JS-0501-SW	Aluminized tube, 10' with hole for rivet
		ALL		JS-0515-SW	Steel tube 10' swaged
		15FT		JS-0515-SW-5S	Steel tube 5' swaged
3	TURN BOX	ALL		JS-0513-TB	U tube turn around box
4	REFLECTOR	ALL		JS-0502-BU	Reflector (24" x 120")
		15FT		JS-0502-BU-5	Reflector (18" x 60")
5	END CAP	ALL		JS-0502-ND	S100U / ITBU series reflector end cap
6	DOUBLE STEEL HANGER	ALL		JS-0505-BU-A	U tube reflector hanger
7	COUPLER	ALL		JA-0516-SW	4" swaged tube coupler torctite
		175 & 200	1st to 2nd tube connections	JA-0516-RK	Tube Connection Kit: Coupler + Rivet + Drill Bit
8	U- BOLT	ALL		JA-0516-UH	U Bolt 4" for U-Tube Hanger
9	IGNITER KIT	ALL		JA-0571-KT	Igniter & gasket kit / DSI tube heater
10	SIGHT GLASS ASSEMBLY	ALL		JS-0536-XX	Sight glass assembly tube heater
11-12	TURBULATOR (see Table 4 in Manual)			JS-0533-UA	Turbulator 24" x 1.25" - Aluminized
				JS-0533-SK	Turbulator 39" x 2" - Stainless Steel
				JS-0533-SH	Turbulator 40" x 1.25" - Aluminized
				JS-0533-SS	Turbulator 60" x 1.25" - Stainless Steel
				JS-0533-UG	Turbulator 72" x 1.25" - Aluminized
				JS-0533-SL	Turbulator 96" x 2" - Stainless Steel
				JS-0533-LG	Turbulator 109" x 1.25" - Aluminized



## LIMITED WARRANTY CERTIFICATE



### FOR GAS-FIRED INFRA-RED LOW INTENSITY TUBE HEATERS: S100 / S100U & ITB / ITBU SERIES

The Manufacturer warrants that this product is free from defects in material or workmanship under normal use and service subject to the terms of this document.

#### TWO YEAR WARRANTY

Subject to the conditions and limitations stated herein, during the term of this limited warranty, we will supply any component part (at our option a new or repaired component part) of the heater as defined below, excluding any labor, which the Manufacturer's examination determines to be defective in workmanship or material for a period of two years (2 years) from the date of installation, unless otherwise specified below. This warranty applies to the heater's original owner, and subsequent transferees and only if the unit is installed and operated in accordance with the printed instructions accompanying the unit and in compliance with all applicable installation codes and good trade practices. Warranty is only applicable to Schwank components, other parts are limited to their own Manufacturers warranty period of one year (1 year).

#### FIVE YEAR WARRANTY

The Manufacturer warrants the burner sub-assembly comprising of ceramic and immediate metal tubing, and the radiating tubes (excluding couplings) for a period of five years (5 years).

#### WHAT IS NOT COVERED

The Manufacturer shall not be responsible for any expenses, including service, labor, diagnosis, analysis, material or transportation charges incurred during removal or reinstallation of this product, or any of its components or parts. All labor or service charges shall be paid by the owner. This warranty does not cover heating products improperly installed, misused, exposed to or damaged by negligence, accident, corrosive or contaminating atmosphere, water, excessive thermal shock, impact, abrasion, normal wear due to use, alteration or operation contrary to the owner's manual or if the serial number has been altered, defaced or removed. This warranty shall not apply if the input to the heating product exceeds by more than 2% of the rated input on the rating plate. The Manufacturer shall not be liable for any default or delay in performance by its warranty caused by any contingency beyond its control, including war, government restrictions, or restraints, strikes, fire, flood, acts of God, or short or reduced supply of raw materials or products.

#### WARRANTY PROCEDURE

To establish the installation date for any purpose under this Limited Warranty, you must retain the original records that can establish the installation date of your unit. If you do not provide such documents, the start date of the term of this Limited Warranty will be based upon the date of unit manufacture, plus thirty (30) days. Failure to maintain the equipment through regular annual service maintenance by a qualified service technician shall void the warranty.

#### LIMITATIONS AND EXCLUSIONS

This document contains all warranties made by the Manufacturer and may not be varied, altered or extended by any person. There are no promises, or agreements extending from the Manufacture other than the statements contained herein. THIS WARRANTY IS IN LIEU OF ALL WARRANTIES EXPRESSED OR IMPLIED, TO THE EXTENT AUTHORIZED BY THE LAWS OF THE JURISDICTION, INCLUDING SPECIFICALLY THE WARRANTIES OR MERCHANTABILITY OF FITNESS FOR A PARTICULAR PURPOSE.

It is understood and agreed that the Manufacturer's obligation hereunder is limited to repairing or replacing parts determined to be defective as stated above. In no event shall the Manufacturer be responsible for any alleged personal injuries or other special, incidental or consequential damages. As to property damages, contract, tort or other claim the Manufacturer's responsibility shall not exceed the purchase price paid for the product.

All replacement parts will be warranted for the unused portion of the warranty coverage period remaining on the applicable unit.

Some Authorities do not allow certain warranty exclusions or limitations on duration of warranty or the exclusions or limitations of incidental or consequential damages. In such cases, the above limitations or exclusions may not apply to you and are not intended to do so where prohibited by law. This warranty gives you specific legal rights. You may also have other rights which vary by jurisdiction.

**SCHWANK**  
2 SCHWANK WAY, WAYNESBORO, GEORGIA. 30830  
5285 BRADCO BLVD. MISSISSAUGA, ON, L4W 2A6

Ph: 1-877-686-3779  
www.SchwankGroup.com

Fax: 1-866-361-0523  
www.InfraSave.com