



Countertop Convection Oven

Intertek Intertek
4010483 4010483
10/2021

Models: 177CO38M (No Steam), 177CO46M (With Steam)

Please read and save these instructions for future reference. Indoor use only.

Index

Important Safeguards	3
Identification of Key Parts	4
Identification of Accessories	4
Usage Guidelines	5
Installation of Your Oven	5
Before Using Your Oven	6
Using Your Oven	6
Typical Operation Sequence	6
Temperature Control Knob	7
Power and Heating Indicator Light	7
Protection Component	7
Cleaning and Maintaining Your Oven	7
Space Clearance	7
Specifications	8
Troubleshooting	8
Parts List	9
Wiring Diagram	10
Limited Replacement Warranty	11

Important Safeguards

When using electrical appliances, basic safety precautions should always be followed, including the following:

1. Read all instructions carefully and completely.
2. For commercial use only.
3. Do not touch hot surfaces.
4. Protect against electrical shock by keeping all cords, plugs, and other electrical components away from water or other liquids.
5. Unplug this unit when not in use and before cleaning.
6. Allow the unit to cool before putting on or taking off parts.
7. Do not operate this or any appliance with a damaged electrical cord or plug.
8. Do not operate this or any appliance after it has malfunctioned or been damaged in any way.
9. Do not use outdoors.
10. Do not place on or near a hot gas or electric burner.
11. Attach plug to appliance first, then plug electrical cord into the wall outlet.
12. Disconnect the unit by turning the temperature and timer control to "OFF", then removing the electrical plug from the wall outlet.
13. Do not use appliance for any application other than intended use.
14. Do not insert metal utensils or oversized foods into this unit as they may cause a fire and heighten the risk of electrical shock.
15. Do not store any item on top of this unit when in operation.
16. Do not allow this oven to touch or be covered by flammable material, such as curtains, draperies, walls, etc., when in operation.
17. Do not clean with metal scouring pads as pieces can break off and touch electrical components, heightening the risk of electrical shock
18. Never place materials such as paper, cardboard, plastic, etc. in this oven.
19. Do not cover interior of this unit with metal foil as it may cause the oven to overheat.
20. Avoid scratching the surface or nicking the edges of this unit's tempered, safety glass door. If the oven door has a scratch or nick, contact customer service before use.
21. Turn the appliance off by turning the temperature and timer control to the "OFF" position.
22. Note that the use of accessories not recommended by the manufacturer may result in injury.
23. Children should be supervised to ensure that they do not play with the oven.
24. This appliance is not intended for use by persons (including children) with reduced physical sensory or mental capabilities, or lack of experience and knowledge, unless they have been given supervision or instruction concerning use of the appliance by a person responsible for their safety.
25. When using the appliance in shops, snack bars, hotels etc., check the voltage and outlet to make sure the appliance is correctly connected with power.
26. Place unit on a flat surface that is well ventilated. The appliances must be supervised during operation, DO NOT leave appliance without powering off.

NOTE: Save these instructions for future reference.

Identification of Key Parts

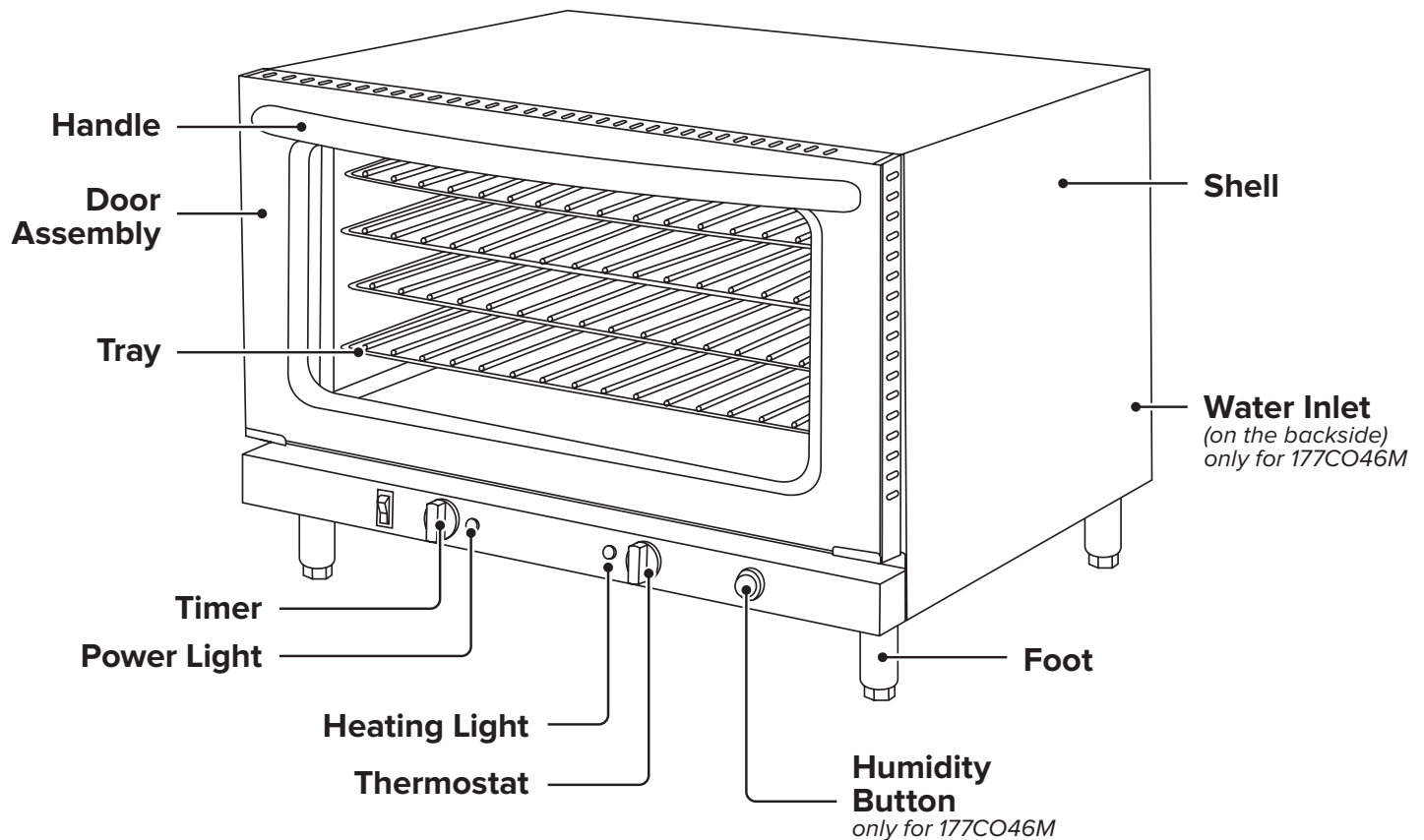

Identification of Accessories

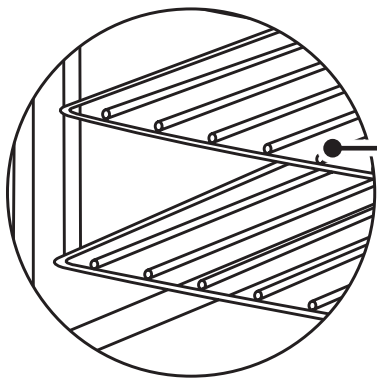

Roasting Racks

- TRAY for 177CO46M and 177CO38M

Recommended Bun Pans

- Full Size (407BUNFULL) for 177CO46M and 177CO38M

Usage Guidelines

208/240V Units

Food Items	Temperature (°F)	Time (Minutes)	Quantity/HR
Cookies	350	15	70
Brownies	325	25	3 Trays
Biscuits	350	30	24
Dinner Rolls	350	18	75
Bacon (sliced)	350	15	4 Trays
Cheese Medium Pizza (frozen)	400	22	4
Baked Chicken Breast 8oz*	375	20	60
Protein (roast) 10lbs*	350	60	10lbs

**Times and temperatures are used as a guide only.*

- Great for supplemental baking, low volume baking, and medium volume sandwich warming at coffee shops, kiosks, churches, schools
- Compact design great for small footprint and countertop needs
- For units that have steam injection mode. This allows you to manually add humidity (not intended for heavy use - see manual)
- Not good for high volume applications, frozen items, sheet cakes, delicate baking, or roasting

Not intended for high volume, high temperature requirements. Intended for supplemental or low volume baking.

Allow proper time for recovery in order to ensure maximum performance.

**Units not intended for daily roasting or baking protein.*

**Units not intended to replace heavy duty floor model convection ovens.*

**Usage: approximately 4 hours per day, 5 days a week.*

Installation of Your Oven

177CO46M and 177CO38M is 208-240V/60Hz, use 6-30P NEMA plug.

All electrical connections must comply with specification and power standard, the installation operation must be done by qualified personnel.

All models are countertop type, put the oven on a flat and level surface, and ensure clearance requirements are met for the air ventilation (see Space Clearance section).

177CO46M is equipped with a steam injection feature. Please install the oven close to water source and connect the faucet well before using.

Using a Water Filtration System is recommended.

Before Using Your Oven

Before cooking anything in your oven for the first time, please follow these simple instructions:

Using a small amount of detergent, wash the handle and roasting racks with soapy water. (NOTE: Do not use a spray or abrasive polishing agent.) Gently wipe down interior walls with a damp cloth. While washing this unit, do not touch the electric heating element. Do not soak the inside of the oven with water.

After washing and thoroughly drying the surfaces noted above, place the roasting racks back inside the oven.

For first-time use of the oven, close the door and turn the bake control to max temperature. Set the timer for 30 minutes. During this burn-in you may notice a slight odor, this is normal. This process helps remove any fumes or odors which may be present.

Using Your Oven

To start your oven, you need to turn on the temperature dial to set your desired cooking temperature, and turn on the timer dial to set the cooking time.

NOTICE: 4" stainless steel legs must be installed to comply with sanitation and airflow clearance requirements. If the legs are not installed properly, the warranty will be voided.

CAUTION: During the baking process, make sure that no metal accessory comes in contact with the electric heating elements.

CAUTION: Foods baked in this oven will be hot. Wear oven mitts when reaching into oven to retrieve food.

Typical Operation Sequence

Action	Result
Plug in your oven	Power is connected but power light will go on after turning the temperature dial
Adjust temperature control knob	Heating indicator light comes on; heating elements begin to heat up
Temperature light shuts off	Oven has reached desired temperature
Load product into oven	Product will begin to cook
Set timer to desired cook time between 0-120 min	Timer starts timing down
Timer reaches zero	Timer chimes
Unload oven	Product will be cooked/hot; use caution removing it from the oven
Steam injection feature	Sprays a small amount of water to enter the baking chamber. Only spray water when the oven temperature is over 400°F and only press the button for 3 seconds maximum at one time. <i>Notice: TOO much water will lower oven temperature, potentially damage elements, or result in water to flow out the chamber.</i>

Temperature Control Knob

The temperature range of this unit is 0-500°F. This thermostatic switch controls the temperature inside the oven and helps to maintain the proper temperature during various heating, roasting, and baking applications.

Power & Temperature Indicator Light

Anytime this appliance is connected to the power supply with the temperature knob turned on, the power and heating indicator light will be on and the fan motor will begin to operate.

Protection Component

If the temperature of this oven reaches an unsafe limit, the electrical components will shut off and it will stop operating in order to prevent overheating.

Cleaning & Maintaining Your Oven

To clean, first remove the power cord's plug from the wall outlet. Wait for the oven to cool. Use a damp cloth or sponge to gently wipe down the inside of the oven. Avoid soaking the inside of the oven or washing it in running water as this will cause serious damage to the unit.

Space Clearance

There must be a minimum of 12" (30.4 cm) between the equipment and any surrounding walls. The surrounding walls must be made of noncombustible materials. The vent located at the rear of the oven must NOT be obstructed. The equipment must be installed in accordance with local fire and building regulations.

Specifications



Model #	Power Supply	Dimensions	Unit Weight	Size	Capacity	Rack #	Plug
177CO38M	208/240V, 60Hz, 3500-2800W	32"W x 28"D x 23"H	100 lbs. (112 lbs. shipping)	Full	4.4 cu. ft.	4 Racks	NEMA 6-30P
177CO46M	208/240V, 60Hz, 3500-4600W	32"W x 28"D x 23"H	100 lbs. (112 lbs. shipping)	Full	4.4 cu. ft.	4 Racks	NEMA 6-30P

Troubleshooting

Problem: The oven does not become hot after being switched on.

- Be sure that the timer switch is set.
- Be sure that the temperature control knob is set.
- Reset switch tripped. Check reset switch on the back of the unit.
- Too much steam was used. May have the damaged element.

Problem: There is a metallic sound when the oven is in use.

- Do not attempt to dismantle the oven.
- Contact your service agent right away to examine the fan.

Problem: Food is often overcooked or burned, even when cooked according to the recipe.

- Check that the fan motor is operating normally.
- Contact your service agent to examine the temperature control knob.
- Oven or racks not level. Check oven racks and level.
- Insufficient air space around trays or baking tins. Ensure oven racks are spaced to allow airflow around baking on all shelves.
- Oven overloaded with too much product. Reload oven with less product.
- Opening oven door unnecessarily. Ensure oven door remains closed during the baking process.
- Oven vent restricted. Ensure oven vent is not blocked or shrouded.
- Premature use of steam or TOO much steam. Allow time for oven to reach back up to temperature.

Problem: There is a loud pop sound or the unit stops working.

Possible Cause: Reset switch tripped. This switch is a safety switch designed to prevent the oven from overheating. If it was triggered the unit was run at too high of a temperature for too long.

Solution: The reset switch is located on the back of the oven, covered by a black plastic screw cap. Remove the cap, press the switch.

