



Drop-In Refrigerated Bakery Display Cases

Black Models: _____

- #360BCDI28B 27½" Curved Glass
- #360BCDI35B 34½" Curved Glass
- #360BCDI48B 48" Curved Glass
- #360BCDI60B 60" Curved Glass

White Models: _____

- #360BCDI28W 27½" Curved Glass
- #360BCDI35W 34½" Curved Glass
- #360BCDI48W 48" Curved Glass
- #360BCDI60W 60" Curved Glass

Note:

You should read this manual in its entirety prior to equipment setup, operation, and maintenance.

www.AvantcoRefrigeration.com

Warnings

DANGER – RISK OF FIRE OR EXPLOSION. FLAMMABLE REFRIGERANT USED. TO BE REPAIRED ONLY BY TRAINED SERVICE PERSONNEL. DO NOT PUNCTURE REFRIGERANT TUBING.

PELIGRO – RIESGO DE INCENDIO O EXPLOSION. REFRIGERANTE INFLAMABLE UTILIZADO. PARA SER REPARADO SOLAMENTE POR PERSONAL DE SERVICIO CALIFICADO. NO PINCHAR LA TUBERÍA REFRIGERANTE.

DANGER – RISQUE DE FEU OU D'EXPLOSION. LE FRIGORIGÈNE EST INFLAMMABLE. CONFIER LES RÉPARATIONS À UN TECHNICIEN SPÉCIALISÉ. NE PAS PERFORER LA TUBULURE CONTENANT LE FRIGORIGÈNE.

CAUTION – RISK OF FIRE OR EXPLOSION. FLAMMABLE REFRIGERANT USED. CONSULT REPAIR MANUAL/OWNER'S GUIDE BEFORE ATTEMPTING TO SERVICE THIS PRODUCT. ALL SAFETY PRECAUTIONS MUST BE FOLLOWED.

ATENCIÓN – RIESGO DE INCENDIO O EXPLOSIÓN. REFRIGERANTE INFLAMABLE UTILIZADO. CONSULTE EL MANUAL DE REPARACIÓN / GUÍA DEL PROPIETARIO ANTES DE INTENTAR DAR SERVICIO A ESTE PRODUCTO. DEBEN CUMPLIR CON TODAS LAS PRECAUCIONES DE SEGURIDAD.

ATTENTION – RISQUE DE FEU OU D'EXPLOSION. LE FRIGORIGÈNE EST INFLAMMABLE. CONSULTER LE MANUEL DU PROPRIÉTAIRE/GUIDE DE RÉPARATION AVANT DE TENTER UNE RÉPARATION. TOUTES LE MESURES DE SÉCURITÉ DOIVENT ÊTRE RESPECTÉES.

CAUTION – RISK OF FIRE OR EXPLOSION DUE TO PUNCTURE OF REFRIGERANT TUBING; FOLLOW HANDLING INSTRUCTIONS CAREFULLY. FLAMMABLE REFRIGERANT USED.

ATENCIÓN – RIESGO DE INCENDIO O EXPLOSIÓN DEBIDO A LA PERFORACION DE LA TUBERÍA REFRIGERANTE; SIGA LAS INSTRUCCIONES DE MANIPULACIÓN CON CUIDADO. REFRIGERANTE INFLAMABLE UTILIZADO.

ATTENTION – RISQUE DE FEU OU D'EXPLOSION SI LA TUBULURE CONTENANT LE FRIGORIGÈNE EST PERFORÉE; SUIVRE LES INSTRUCTIONS DE MANUTENTION AVEC SOIN. LE FRIGORIGÈNE EST INFLAMMABLE.

CAUTION – RISK OF FIRE OR EXPLOSION DUE TO FLAMMABLE REFRIGERANT USED. FOLLOW HANDLING INSTRUCTIONS CAREFULLY IN COMPLIANCE WITH LOCAL GOVERNMENT REGULATIONS.

ATENCIÓN – RIESGO DE INCENDIO O EXPLOSIÓN DEBIDO A REFRIGERANTE INFLAMABLE UTILIZADO. SIGA LAS INSTRUCCIONES DE MANIPULACIÓN CON CUIDADO CONFORME A LAS REGLAS DE LA MUNICIPALIDAD.

ATTENTION – RISQUE DE FEU OU D'EXPLOSION SI LE FRIGORIGÈNE EST INFLAMMABLE. SUIVRE LES INSTRUCTIONS DE MANUTENTION AVEC SOIN CONFORMÉMENT AUX RÈGLEMENTATION GOUVERNEMENTALE LOCAUX.

Installation

This unit is intended for use in a temperature-controlled environment of less than 75°F and 55% relative humidity. Malfunction due to improper conditions is not covered under warranty.

Before Installation

- If the unit has recently been transported on its side, please let unit stand upright for a minimum of 24 hours before plugging it in.
- Make sure that the unit has reached the desired temperature before loading the unit with products. This unit is meant for keeping cold products cold, not chilling warm products.
- Make sure that there is proper ventilation around the unit in the area where it will operate.
- Make sure all accessories are installed (i.e., shelves, shelf clips, casters) before plugging in the unit.
- Do not attempt to remove or repair any component of the unit. Consult an authorized service technician for servicing/repair.
- Do not sit inside the unit or hang on doors.
- This unit should be located away from doors, air ducts, and fans that could disrupt airflow and negatively impact performance.
- Please read through the manual in its entirety.

Cabinet Location Guidelines

- Install the unit on strong and leveled surfaces.
 - If the surface is uneven, the unit may be noisy.
 - The unit may malfunction if the surface is uneven.
- Install the unit in an indoor, well-ventilated area.
 - For best performance, please maintain clearance of 6" on the back of the unit.
 - Do not use outdoors. For indoor use only.
 - Avoid direct sunlight.
- Avoid installation in a high humidity and/or dusty area.
 - Humidity above 55% can cause the unit to rust, collect condensation, and may decrease efficiency.
 - Dust collected on condenser coil will cause unit to malfunction.
 - Malfunction due to temperatures above 75 degrees Fahrenheit, humidity above 55%, or improperly maintained condenser coil will void the warranty.
- Select a location away from heat and moisture-generating equipment.
 - Ambient temperatures above 75 degrees Fahrenheit may cause the compressor to malfunction.
 - Malfunction due to ambient temperatures above 75 degrees Fahrenheit will void warranty.
 - Do not install the unit inside a closet or alcove.

Installation

Drop-In Procedure

- Hole cutting should be done by a professional.
- The counter must be able to hold the weight of the case.
- The surface must be level to have even force supporting the case.
- When installed, drop-in cases should be lowered down from both sides so they are level.
- The cabinet CANNOT be completely closed off. There must be air flow for the refrigeration to function.
- **The cutout into the cabinet must have a minimum of 4" from each edge of the countertop to properly support the drop-in bakery case.**

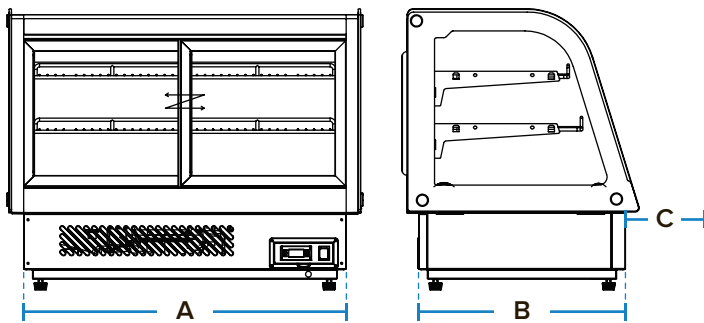

Item #	Cut-Out Width (A)	Cut-Out Depth (B)	Minimum Counter Width (C)
360BCDI28 (B/W)	25"	20¾"	4"
360BCDI35 (B/W)	32"	20¾"	4"
360BCDI48 (B/W)	45¾"	20¾"	4"
360BCDI60 (B/W)	57¾"	20¾"	4"

Electrical

- Ensure that the required voltage is being supplied at all times.
- The unit should be plugged into a grounded and properly-sized electrical outlet with appropriate over-current protection. Refer to the electrical requirements on the unit's nameplate.
- The unit should have its own dedicated outlet.
- DO NOT use extension cords.
- Ensure the unit is not resting on or against the electrical cord.
- If the unit is not in use for a long period of time, unplug from the outlet.
- To avoid shock and fire hazards, DO NOT plug in or unplug the unit with wet hands.
- After unplugging the unit, wait at least 10 minutes before plugging it back in. Failure to do so could cause damage to the compressor.

Temperature Controls

Adjusting the Temperature

- Your new refrigerator is already factory-set to run at optimum temperatures for food safety and should require no adjustments.

Front Panel Operation

- Set temperature:
 - Press "SET" button, the set temperature is displayed.
 - Use the arrow buttons to adjust the displayed value.
 - Press "SET" button to exit the adjustment and display the unit's current temperature.
- If no buttons are pressed within 10 seconds, the unit's current temperature will be displayed.
- Lights:
 - Press "LIGHT" button to turn lights on or off.
- Manual start/stop defrost:
 - Press and hold "LIGHT" button for 6 seconds.
- Refrigerant LED:
 - When the compressor is running, the LED is on.
 - When the refrigerator temperature is constant, the LED is off.
 - During the delay start, the LED flashes.
- Defrost LED:
 - During the defrost cycle, the LED is on.
 - When defrost cycle is done, the LED is off.
 - During the delayed display of defrost, the LED flashes.

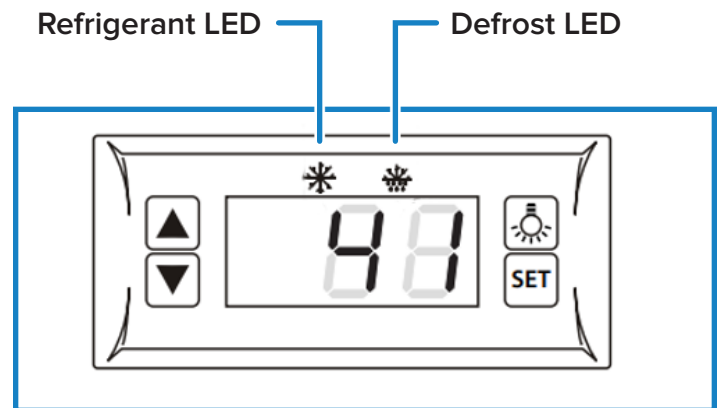

Operation

Defrost System

Automatic Defrost Cycle

- Refrigerator coils are kept below the freezing point (32°F).
- During compressor downtime, the evaporator fan continues to circulate air through the evaporator coil. This air circulation raises the coil temperature above the freezing point, melting any accumulated frost.
- Run-off water is drained into the evaporator pan and evaporated.

Operation

Loading Product

- DO NOT block the air vents.
- Ensure all shelves are sitting level and properly secured before loading products.
- DO NOT store flammable/explosive gas or liquids inside the unit.

Safety Information

Pay close attention to the safety notices in this section. Disregarding these notices may lead to serious injury and/or damage to the unit.

- To minimize shock and fire hazards, be sure to not overload outlet. This unit should be given its own outlet.
- DO NOT use extension cords.
- DO NOT put your hands under the unit while it is being moved.
- When the unit is not in use for a long period of time, unplug the unit from the outlet.
- After unplugging the unit, wait at least 10 minutes before plugging it back in. Failure to do so could cause damage to the compressor.
- To minimize shock and fire hazards, do not plug or unplug the cord with wet hands.
- Unplug the unit before performing maintenance or cleaning.
- To minimize shock and fire hazards, make sure that the unit is properly grounded.
- DO NOT attempt to remove or repair any component unless instructed by the factory.
- DO NOT allow the unit to rest on or against the electrical cord and/or plug.
- DO NOT store any flammable/explosive gas or liquids inside the unit.
- DO NOT attempt to alter or tamper with the electrical cord.
- DO NOT use the unit if the power cord is damaged.

Cleaning

DISCONNECT POWER CORD BEFORE CLEANING ANY PARTS OF THE UNIT.

It is strongly recommended that any servicing of the unit be performed by an authorized service technician.

Fan Blades & Motor

- If necessary, clean the fan blades and motor with a soft cloth.
- If it is necessary to wash the fan blades more thoroughly, cover the fan motor to prevent moisture damage, then use a damp cloth to clean the fan blades.

Interior

- Use warm water and a mild soap with a clean cloth to wipe down the interior of the unit.
- DO NOT use steel wool, caustic soap, abrasive cleaners, or bleach that may damage the interior finish.
- Periodically remove the shelves and pilasters from the unit and clean them with mild soap and warm water. To remove the pilasters, first remove the shelves and shelf brackets. Then, simply lift the pilaster up and out.

Cleaning the Condenser Coil

- A dusty condenser may lead to high energy consumption, less cooling effectiveness, and compressor damage.
- For efficient operation, keep the condenser surface free of dust, dirt, and lint.
- We recommend cleaning the condenser coil at least once per month.
- The condenser coil is located at the bottom behind the panel.
- Once a month, remove the condenser filter and gently clean it with a dry brush.

Cleaning the Condenser Coil Instructions

1. Disconnect the electrical power from the unit.
2. Remove the front cover and base cover with a screwdriver.
3. Using a soft brush and/or vacuum, remove the dirt, lint, etc. from the finned condenser coil in a vertical direction.
4. Clean the condenser with a commercial condenser coil cleaner, available from any kitchen equipment retailer. Ex. Noble Chemical Tech Line Coil Cleaners (148TLECCCLNR, 148TLHDCCLNR, 148TLECOILDD, 148TLFMCCCLNR, 147TLEVPCLNR, or 147TLHDCCLNR).
5. After cleaning, straighten any bent condenser fins with a fin comb.
6. When finished, be sure to reinstall the front cover and base cover.
7. Reconnect the electrical power to the unit.

Troubleshooting

Problem	Possible Cause	Possible Solution
Compressor not running.	Fuse blown or circuit breaker tripped.	Replace fuse or reset circuit breaker.
	Power cord unplugged.	Plug in power cord.
	Thermostat set too high.	Set thermostat to lower temperature.
	Cabinet in defrost cycle.	Wait for defrost cycle to finish.
Condensing units run for long periods of time.	Excessive amount of warm product placed in cabinet.	Allow adequate time for product to cool down.
	Prolonged door opening or door ajar.	Ensure doors are closed when not in use. Avoid opening doors for long periods of time.
	Dirty condenser coil.	Clean the condenser coil. (Page 7)
	Evaporator coil iced over.	Unplug unit and allow coil to defrost. Make sure thermostat is not set too cold. Ensure that door gasket(s) are sealing properly.
Cabinet temperature is too warm.	Thermostat set too warm.	Set thermostat to lower temperature.
	Airflow blocked.	Re-arrange product to allow for proper airflow. Make sure there is at least four inches of clearance from evaporator.
	Excessive amount of warm product placed in cabinet.	Allow adequate time for product to cool down.
	Fuse blown or circuit breaker tripped.	Replace fuse or reset circuit breaker.
	Dirty condenser coil.	Clean the condenser coil. (Page 7)
	Evaporator coil iced over.	Ensure doors are closed when not in use. Avoid opening doors for long periods of time.
	Low refrigerant levels.	Contact a service technician to check refrigerant levels.
	Door is slightly ajar.	Make sure door is completely closed.
Condensation is collecting on the cabinet and/or floor.	Relative humidity is above 55%.	Move unit to area below relative humidity or lower humidity level.
Interior light is not working.	Poor switch connection.	Turn off light switch and turn it back on.
	Bulb is not connected.	Make sure the bulb is correctly inserted in the socket.
	Bulb has burned out.	Replace the bulb.