



Countertop Meat & Bone Saw

Models: _____

#177EMBS65SS 65" • 120V • 1 HP

Warning:

Improper installation, adjustment, alteration, service, or maintenance can cause property damage, injury, or death. Read the installation, operating, and maintenance instructions thoroughly before installing or servicing this equipment.

For Your Safety:

Do not store or use gasoline or other flammable vapors or liquids in the vicinity of this or any other appliance.

Note:

Please read and keep these instructions. Indoor use only.

Table of Contents

Specifications 2

Safety Precautions 3

Parts Identification 4

Installation 4

Operation 5

Replacing the Saw Blade 6

Cleaning & Maintenance 7

Troubleshooting..... 8

Specifications

Model	177EMBS65SS
Motor	1 HP
Blade	65"
Blade Speed	50' / sec.
Cutting Thickness	8"
Max. Cutting Height	8"
Max. Cutting Width	7"
Table Size	28" x 31½"



Intertek
3067171



Intertek
3067171



NEMA
5-15P

CONFORMS TO NSF STD. 8
CONFORMS TO UL STD. 763
CONFORMS TO CSA STD. C22.2 NO 195

Safety Precautions



WARNING

- Read all instructions carefully and completely.
- For commercial use only.
- Protect against electrical shock by keeping all cords, plugs, and other electrical components away from water or other liquids.
- Safety gloves should ALWAYS be worn when operating this unit.
- Unplug from power source when not in use and before cleaning.
- DO NOT operate this unit or any appliance with a damaged electrical cord or plug.
- DO NOT operate this or any appliance after it has malfunctioned or has been damaged in any way.
- DO NOT use outdoors.
- Disconnect the unit by removing plug from outlet.
- DO NOT use appliance for any application other than its intended use.
- DO NOT store any item on top of this unit when in operation.
- DO NOT allow this unit to touch or to be covered by flammable material such as curtains, draperies, walls, etc. when in operation.
- DO NOT clean with metal scouring pads, as pieces can break off and touch electrical components, heightening the risk of electrical shock.
- Avoid scratching the surface or nicking the edges of this unit.
- This unit requires a team lift to unbox and put in its end location.
- Note that the use of accessories not recommended by the manufacturer may result in injury.
- Children should be supervised to ensure that they DO NOT play with the unit.
- This appliance is not intended for use by persons (including children) with reduced physical, sensory, or mental capabilities, or lack of experience and knowledge, unless a person responsible for their safety has given them supervision or instruction concerning use of the appliance.
- ALWAYS keep all loose clothing away from moving parts when the saw is in use.
- ALWAYS keep fingers and hair away from moving parts when saw is in use.
- Avoid contact with moving parts.
- DO NOT use fingers to scrape food away from the discharge disc while the appliance is operating. Injury may occur.

Save these instructions for future reference.

Parts Identification

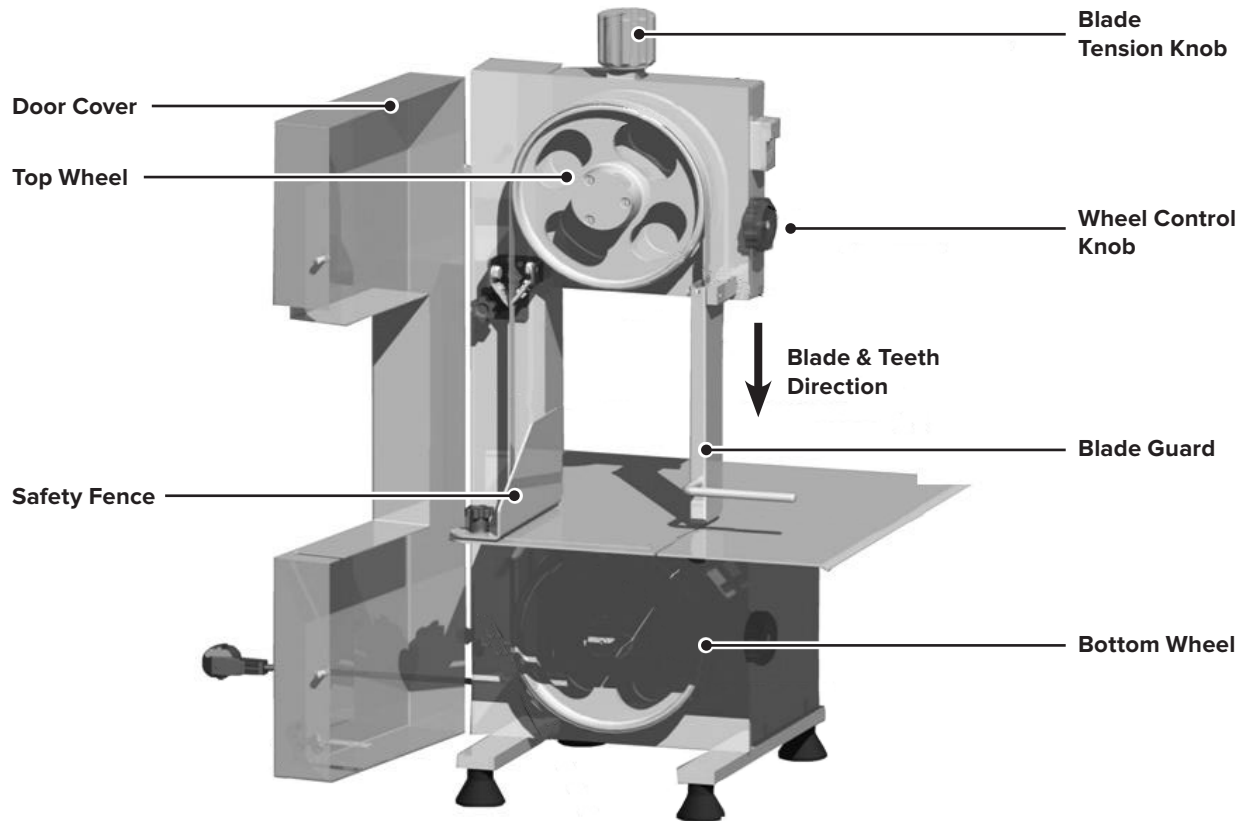

Installation

WARNING

- Ensure that the outlet you will be using matches the power needs of the unit.
 - Electrical and grounding connections must comply with the applicable portion of the National Electrical Code and/or other local electrical codes.
1. This saw is fully assembled and ready to be used right out of the box.
 2. Place onto a flat, level surface that is capable of withstanding vibration.
 3. Ensure there is nothing that will impede the operation of the machine or make contact with any moving parts.
 4. Open the door cover of the machine and inspect that the saw blade is correctly fixed to both the top and bottom wheel. The teeth edge of the blade should be flush with the edge of the wheels (if misaligned, see Replacing the Saw Blade on page 6).
 5. Close the door cover and turn the wheel control knob counterclockwise.
 6. Turn the saw on by pressing the ON switch. While the unit is on, ensure that the blade is moving in a clockwise manner.
 7. Turn off the machine by pressing the OFF switch.

Operation

CAUTION

- **ALWAYS** wear safety gloves while operating the tabletop butcher saw.
- This machine is equipped with a safety switch that will turn the machine off when the door cover is opened. This process is not immediate, so the blade may still be in motion for a time if the door cover is opened while in operation.
- **ALWAYS** check the scrapers (Fig. 1) near each wheel to ensure that they lean against the blade, but **DO NOT** make contact with the teeth of the blade. The scraper removes meat scraps from the blade when the machine is working.

1. Ensure the blade is tight on the wheels by turning the tension knob clockwise until it clicks in place. (Fig. 2)
2. Set the distance between the safety fence and blade to the desired meat thickness. (Fig. 3)
3. Set the meat on the tray so its left side is resting against the fence.
4. Turn the machine on by pressing the ON button.
5. Push the meat slowly and steadily straight through the blade using the push plate or blade guard. (Fig. 4)
6. Return to the original position and repeat.
7. When finished cutting, turn the machine off.
8. When the machine comes to a complete stop, turn the tension knob counterclockwise for two revolutions to release tension on the blade, which can help increase the life of the blade. (Fig. 2)
9. The machine should be thoroughly cleaned after every use.



Replacing the Saw Blade

CAUTION

- ALWAYS wear safety gloves while replacing and handling the saw blades.
- ALWAYS match the correct saw blade to the type of food that you are cutting.

1. Turn the unit off and allow blades to come to a complete stop.
2. Open the door cover to expose the wheels and blade.
3. Loosen the blade by turning the tension knob counterclockwise. (Fig. 5)
4. Take note of the direction the blades are going. Carefully remove the old blade and replace with new blade, matching the direction of the removed blade. (Fig. 6)
Note: The teeth of the blade should be facing you. The blade will move in a clockwise motion.
5. Make sure the saw blade and slicer are installed between the top wheel and bottom pulley/middle plate, and that they pass through the guide groove.
6. Check that the scrapers are angled toward the blade, but not making contact with the teeth. (Fig. 7)
7. After installing the new blade, turn the tension knob to the point that the knob clicks in place. This sound means the blade has the correct amount of tension. (Fig. 5)

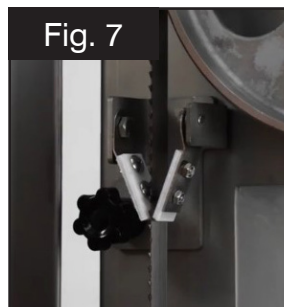
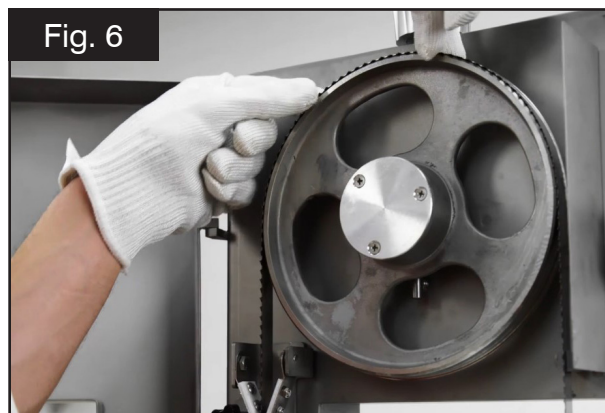

Cleaning & Maintenance

CAUTION

- **ALWAYS** wear safety gloves while replacing and handling the saw blades.
- **ALWAYS** disconnect the saw from its electrical power supply before performing any cleaning, inspection, or maintenance.

1. Turn unit off and unplug.
2. Ensure the unit has cooled completely.
3. Open the door cover.
4. Remove any excess food material and discard.
5. Inspect unit and blade to ensure there is no breakage or corrosion.
6. Loosen the blade tension by turning the tension control knob counterclockwise. (Fig. 8)
7. Remove the saw blade, taking note of its orientation for reinstallation. (Fig. 9)
8. Remove scrapers by loosening the scraper protection knob. (Fig. 10)
9. Working from the top down, clean the inside of the machine by using an all-purpose cleaner/degreaser (such as Noble Chemical Strike), hot water, and a hard brush.
10. Pay close attention to the entire path that the saw blade follows, the wheels, and any corners and crevices that may collect debris.
11. Remove the scrap tray, empty contents, and clean thoroughly.
12. Dry the interior with a clean cloth. Do not close the door cover until fully dry.
13. While the interior dries, clean the work surface, safety fence, push plate, and blade guard in the same manner as the inside.
14. The blade and scrapers can be cleaned with hot water and detergent. Allow to dry fully before reinstalling. A light application of a food grade oil can be applied to the blade to prevent rust.

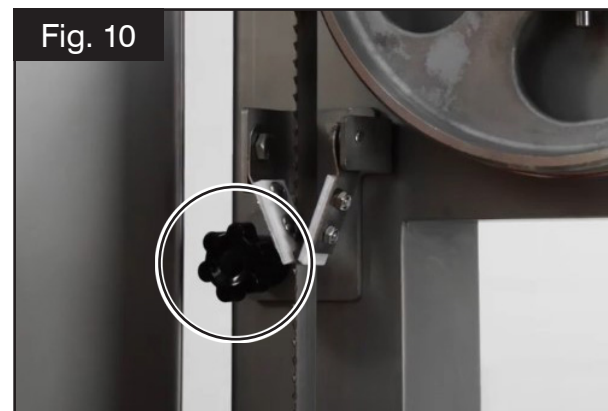

Continued on next page.

Cleaning & Maintenance

15. Removable parts can be sanitized using a standard 3 sink cleaning method.
 - Sink 1: Wash with hot water, detergent, and a brush.
 - Sink 2: Rinse with hot water.
 - Sink 3: Sanitize with a third sink sanitizer (such as Noble Chemical Bacti-Free).
16. Non-removable food contact parts and surfaces can be sanitized using a food-safe sanitizer (such as Noble Chemical QuikSan).
17. The exterior of the unit (that does NOT make contact with food) can be cleaned with a stainless steel cleaner (such as Noble Chemical Excel).
18. When everything has completely dried, reassemble the machine, ensuring parts are properly calibrated and lined up.
19. A food grade lubricant (such as Noble Chemical Lubriquik) can be applied to the wheel shafts as needed.
20. Allow unit to air dry completely before use.

Troubleshooting

Issue	Solution
The blade is loose.	Tighten the blade by turning the tension handle clockwise.
The blade is not cutting through the meat.	Check if the blade is damaged. If so, replace the blade.
Meat saw is not operating properly.	Check that the power source is operating properly.
	Check that the door cover is closed properly.