

## OPERATING AND MAINTENANCE INSTRUCTIONS

(Read the entire sheet carefully and retain for future reference)

### LADDER INSPECTION

- Upon receipt, inspect each unit immediately for damage incurred during shipping. If damage has occurred, sign for ladder as DAMAGED, contact the freight carrier and the manufacturer immediately. **DO NOT USE LADDER.**
- Inspect all ladders prior to each use, any ladders damaged or weakened from any cause **SHALL NOT BE USED** until repaired or replaced. Ladders damaged or worn beyond repair shall be destroyed. **NEVER** climb a damaged ladder.
- If assembly is required ensure all bracing is properly fitted.
- Ensure that all rubber tips are installed on all legs. Replace all tips that are worn.
- Check brake mechanism. All legs must rest firmly on the floor before climbing.
- Ensure all fasteners are properly tightened.
- Missing or worn labels must be replaced, please contact the manufacturer.

### LADDER USE

- All employees shall be instructed by employer in the proper use of the unit, and shall read the operating instructions before being allowed to use any unit.
- Employees must read and obey all instruction labels attached to the unit.
- Units must not be loaded beyond the weight marked on the label.
- The user shall face the ladder and use the handrail when ascending or descending. Overreaching while on a unit could cause instability and result in a fall.
- Additional height shall not be gained by the addition of any type of extension or object being placed on the unit.
- Do not stand on railing or top guardrail. The user shall not ascend farther than the top step.
- Foreign material such as grease shall be removed from shoes prior to ascent of a unit.
- Access to or egress from any step or platform from any other elevated surface shall be prohibited unless the unit has been positively secured against any movement.
- **DO NOT USE** ladder when occupied.
- **DO NOT USE** near open electrical circuits, contact with an energized circuit or conductor will cause an electrical shock.
- **DO NOT USE** in front of a door unless the door is secured in an open position, locked or guarded.
- **DO NOT USE** on an uneven or sloping surface, units are to be used on a flat level surface.
- **DO NOT USE** if you tire easily, are subject to fainting spells, use medicine, alcohol, or are physically handicapped.



## Mobile Ladder Stand Assembly Instructions for 2-4 step standard incline (SR) models

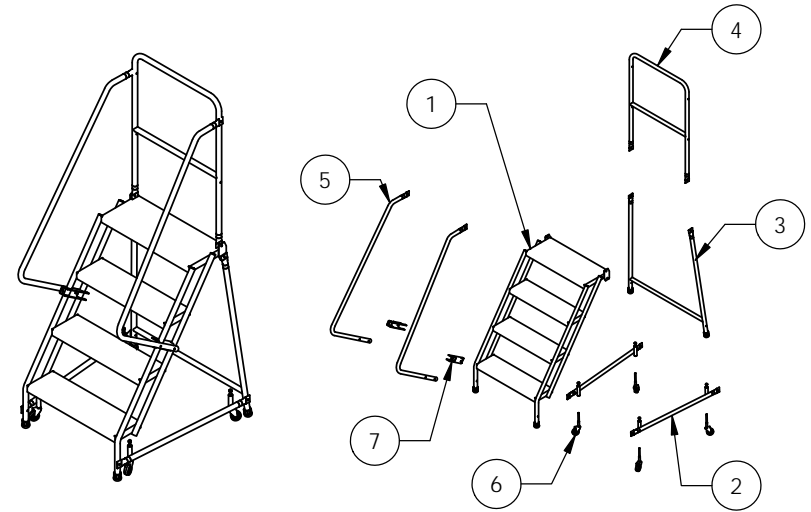

| COMPONENTS |                         |                            |                                    |
|------------|-------------------------|----------------------------|------------------------------------|
|            | 2-4 STEP WITH HANDRAILS | 2-4 STEP WITHOUT HANDRAILS |                                    |
| PART #     | QTY                     | QTY                        | DESCRIPTION                        |
| 1          | 1                       | 1                          | STRINGER ASSEMBLY                  |
| 2          | 2                       | 2                          | BOTTOM LEG                         |
| 3          | 1                       | 1                          | BACK ASSEMBLY (WELDED)             |
| 4          | 1                       | 0                          | GUARDRAIL                          |
| 5          | 2                       | 0                          | HANDRAIL                           |
| 6          | 4                       | 4                          | CASTERS (IN FASTENER PACK)         |
| 7          | 2                       | 0                          | HANDRAIL CLAMPS (IN FASTENER PACK) |
|            | 4                       | 4                          | SPRINGS (IN FASTENER PACK)         |
|            | 4                       | 4                          | ACORN NUTS (IN FASTENER PACK)      |
|            | 1                       | 1                          | FASTENER PACK                      |

\* TOOLS REQUIRED - UTILITY KNIFE, 1/2" SOCKET WRENCH, & OPEN END WRENCH



800-565-2165  
www.tri-arc.com

1. If you purchased a Deep Top ladder, be sure to read the supplemental instruction packets prior to any assembly.
2. Place the stringer on a firm working surface, laying on its side. The back assembly ships fastened to the stringer but is folded flat.
3. Attach a bottom leg to the inside of the stringer, using a 5/16" x 1-1/2" bolt through the hole above end of the tube. Make sure the caster sockets are on the inside of the ladder, with the large hole pointing to the bottom.
4. Now attach the other end of that bottom leg to the back on that side, through the vertical tube, using a 5/16" x 1-3/4" bolt.

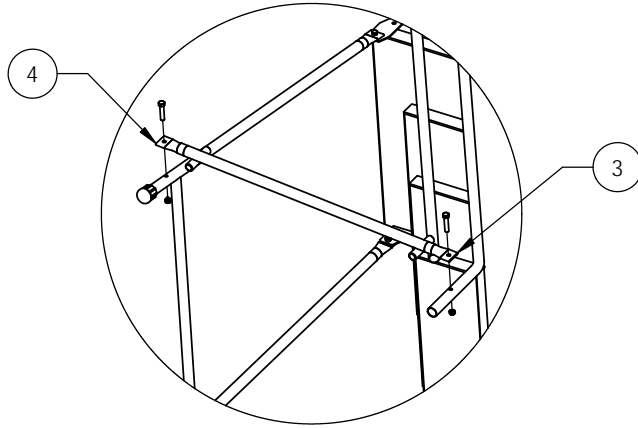

8. Flip the ladder upright into its bottom and tighten all the nuts.
9. Slide a spring over the shaft of the compression caster, then insert it into a socket on the bottom leg until the threaded end sticks out the top. Then use an acorn nut to secure it tightly. Repeat for all 4 casters.
10. Check to ensure that a washer is inside each of the 4 crutch tips. Slide the crutch tips onto the ends of the tubing at each of the four feet.
11. Press a plastic plug (found in the fastener pack) into the ends of each of the 4 tubes welded to the top step.

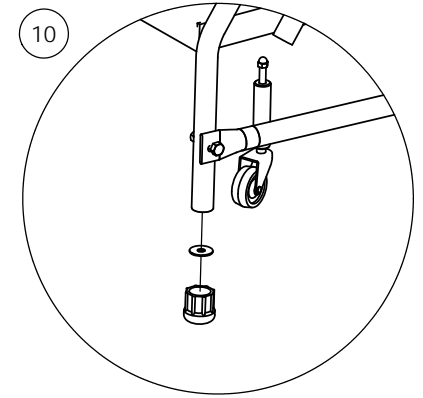
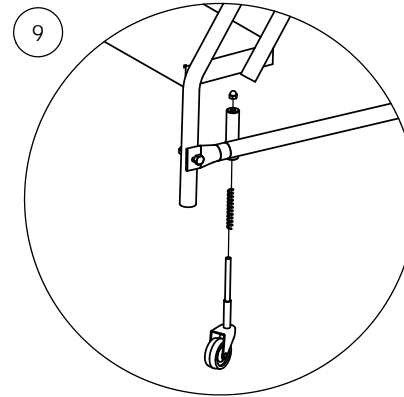

(For ladders without handrails, skip steps 5 & 6.)

5. Attach the rear guardrail to the back of the top step using two 5/16" x 1" bolts.
6. Attach the handrail to the holes on the guardrail using a 5/16" x 1-1/2" bolt. The other end of the handrail using the handrail clamp and two 5/16" x 1-3/4" bolts. The handrail goes on the outside of the stringer rails, while the clamp will be on the inside.
7. Turn the ladder over and repeat the steps above for the parts on the other side.

