



**AIR-PRO™**  
AIR DOORS

## INSTALLATION INSTRUCTIONS

BEFORE PROCEEDING, PLEASE READ AND SAVE THESE INSTRUCTIONS

If the Air Door unit has been damaged in shipping, immediately notify the transport company.

**IMPORTANT**  
By dropping the Air Door on its side during shipping the blower wheels may come out of the side bushing. This must be corrected prior to operating the unit. **1)** Remove the intake grill and the four screws on the side of the unit to remove the end plate. **2)** Loosen the screw that attaches the blower wheels to the motor shaft and remove the blower wheels. **3)** Insert the metal wheel from the end of the blower wheels into the rubber bushing. **4)** Slide the blower wheels into the side of the unit over the motor shaft and reattach the four screws to the side of the unit. **5)** Tighten the blower wheels to the motor shaft and replace the intake grill.

### MOUNTING (Interior Applications)

**Never install your Air-Pro Air Door in an adverse environment, such as, near splashing water, excess steam, explosive or corrosive gases.**

#### Wall Mounting

1. Remove the mounting plate locking screws from the back bottom corners of the unit and detach the mounting plate from the back of the unit. **Figure 1.**
2. Keeping the mounting plate level, center it over the doorway opening. Be sure the lipped edge of the plate is at the top. **Figure 2. Note:** The bottom edge of the mounting plate should be no more than 108" from the floor.
3. Mark the pre-drilled holes, remove the plate and check to make sure you are tying into firm supporting material, i.e. studs, header or block. **Note:** There should be at least 4 secure mounting holes used. If not, drill 4 new holes in the mounting plate to accommodate a secure attachment. Drill the wall holes.
4. Attach the mounting plate. (Screws not supplied)

#### Solid Wall Mounting

1. Perform the first two steps under "Wall Mounting" (see above).
2. Mark the 4 outside pre-drilled holes and remove the plate.
3. Drill the 4 anchor holes and place anchors in each hole. **Figure 3.**
4. Attach the mounting plate. (Screws not supplied)

#### Ceiling Mounting

If mounting the air door to the ceiling is necessary, you will need to order our mounting brackets (optional). Also, 4 threaded rods (supplied by others) will be needed.

1. Secure the 4 threaded rods to the ceiling at the proper distance from the floor taking the height of the air door unit into consideration.
2. Using a hex bolt, washer and nut, attach each bracket to the mounting plate using the pre-drilled holes. Make sure the lipped edge of the plate is at the top.
3. Holding the assembly in place, fasten the rods to the bracket collars. **Figure 4.**

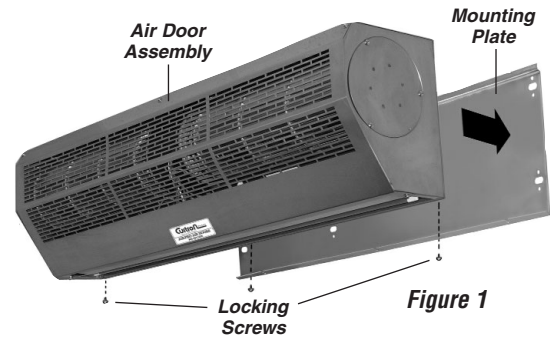

Figure 1

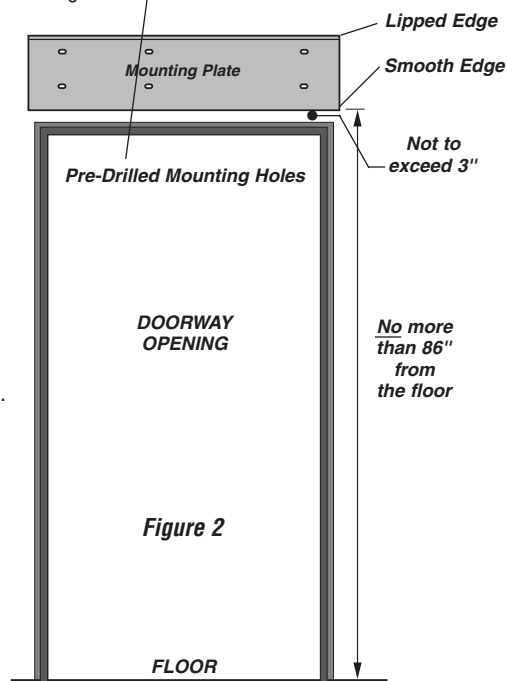

Figure 2

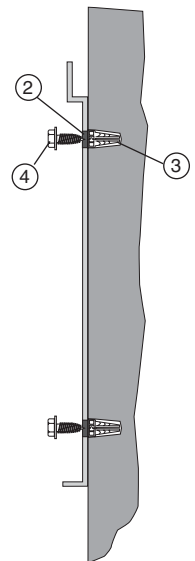

Figure 3

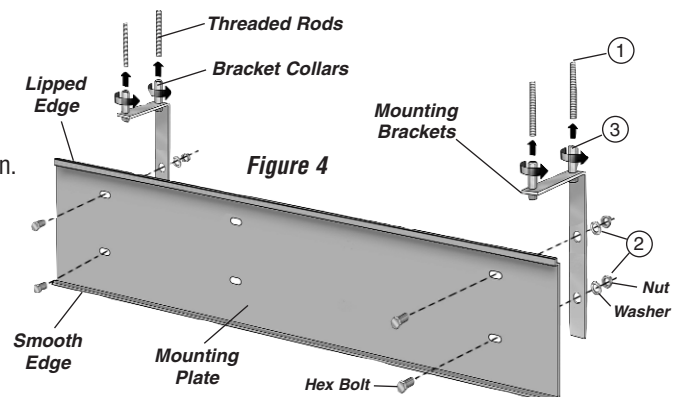

Figure 4

# MOUNTING

## Attaching the Air Door to the Mounting Plate

After the Mounting Plate had been securely attached using one of the mounting methods, the air door must be attached to the mounting plate.

1. Lift the unit, into place with the outlet nozzle at the bottom and the intake grill facing away from the mounting plate.

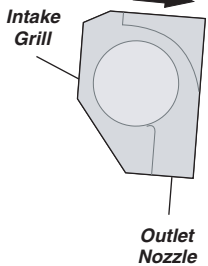

2. Slip the unit over the mounting plate lip.

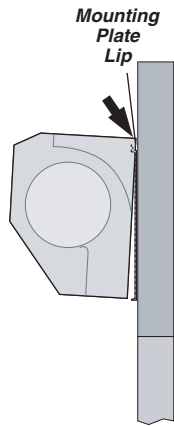

3. Gently push the unit down so it rests on the lip.

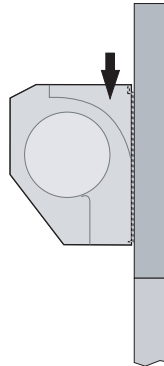

4. Replace all the mounting plate screws and firmly tighten.

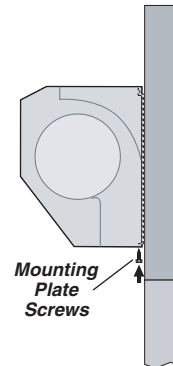

4. Plug the unit into a properly grounded 3 prong, 120 V electrical outlet.



# ADJUSTMENTS

Once your air door has been installed, it will be necessary to adjust the air flow. With the door all the way open, turn the unit on "High," find the air stream split by holding a square piece of light weight cloth by its corners in the stream of air and move it back and forth (inside and outside), approximately 6" from the floor. The cloth will show the flow pattern and will allow you to make the proper adjustments to the directional vane for maximum efficiency. If your unit is properly adjusted, the split should be just outside the threshold with the top of the air current being about 2' from the floor.

The air flow angle can easily be adjusted by turning the directional vane using your hand. No tools are needed. The angle of the air flow depends on the height of the door and is normally between 5° and 10°.

It should never exceed 20°.

If the air current is too severe or exceeds the 2' level, you can turn the power switch to "Low."

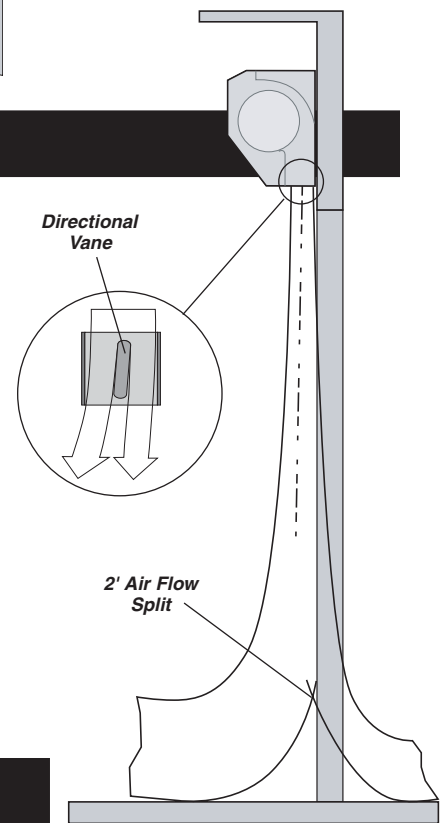

# SPECIAL APPLICATIONS

## Mounting Above the Ceiling

1. Mount the Air Door using the "Wall Mounting" method (see page 1).
2. The intake vent should be at least 36" away from the outlet vent.
3. It is extremely important to fabricate the intake ductwork so it encapsulates the entire intake grill. **Figure 5.**

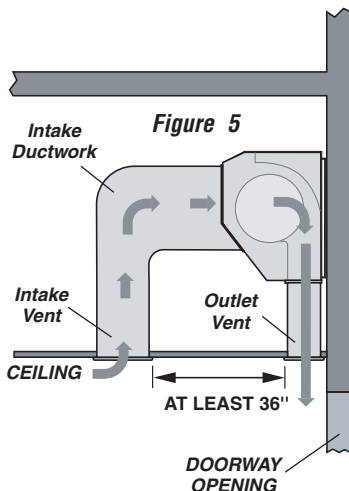

## Mounting Tandem Units

1. Mount the Air Doors using any of the mounting methods (see page 1).
2. The space between units should be between 1" and 2". **Figure 6.**

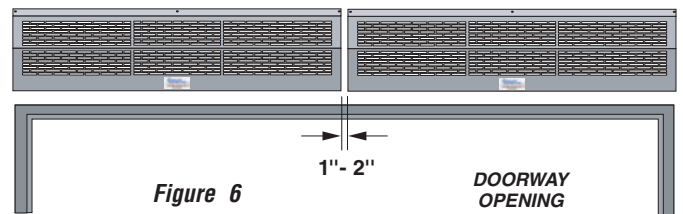

## CLEANING and MAINTENANCE

Once a year the air door's internal parts should be cleaned and serviced.

**CAUTION: Electric Shock Hazard**

Disconnect the power line before working on any unit.

1. Loosen the intake grill mounting screws and remove the grill.
2. Vacuum inside the cabinet and around the fan baskets. Check for any potential problems and perform any appropriate service.
3. Using mild soap and water, wipe the intake grill, directional vanes and units housing with a damp cloth.
4. Replace the intake grill and plug-in the unit.

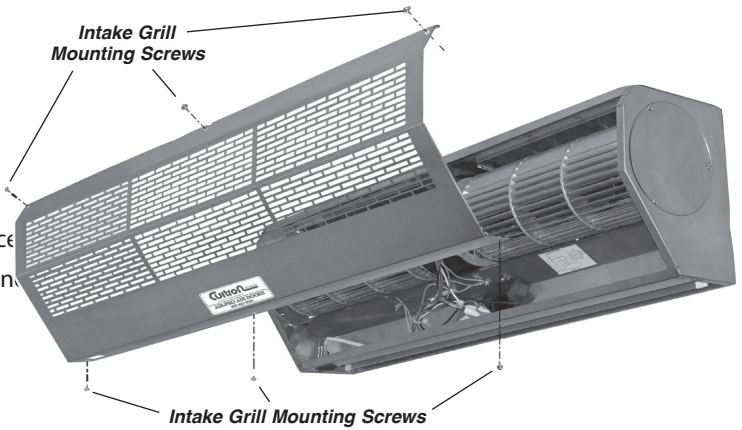

## TECHNICAL SPECIFICATIONS

Model	Diameter of Wheel (in.)	Voltage	Frequency (Hz)	Maximum Capacity (kW)		Maximum Air Speed (fpm)		Sound Level (dBA)		Air Volume (cfm)		Net Weight. (lbs.)	Dimensions (in.) L x W x H
				Hi	Low	Hi	Low	Hi	Low	Hi	Low		
IBD-2-36-1-SS	5.5	110-120	60	.50	.495	3149	2559	69	67	1212	989	43	36" x 8.5" x 10"
IBD-2-42-1-SS	5.5	110-120	60	.65	.645	3149	2559	71	69	1353	1101	47	40" x 8.5" x 10"
IBD-2-48-1-SS	5.5	110-120	60	.65	.645	3149	2559	73	71	1860	1513	53	48" x 8.5" x 10"
IBD-3-60-1-SS	5.5	110-120	60	.80	.795	3149	2559	75	73	2325	1889	62	60" x 8.5" x 10"

## AUTOMATIC DOOR PLUNGER SWITCH INSTALLATION (Optional)

**CAUTION: Electric Shock Hazard**

Unplug the power line before working on the unit.

1. Remove the front intake grill.
2. Use the knock out on one side of the Air-Pro Air Door.  
Use only one knockout (which would be the closest to the installation of the door plunger switch).
3. Install the door plunger switch at the door opening
4. Wire the plunger switch according to the diagram to the right.
5. Replace the front intake grill.
6. Plug in the Air-Pro Air Door.

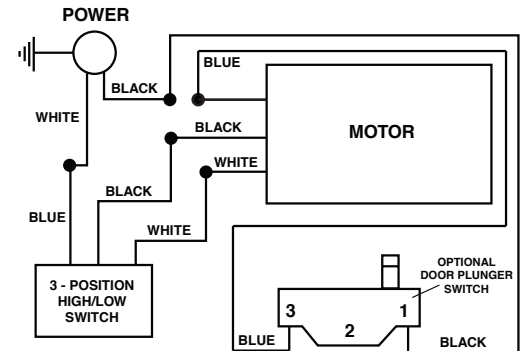

NOTES: