

This page is for printing and document
formatting specifications only.
THIS PAGE DOES NOT PRINT.

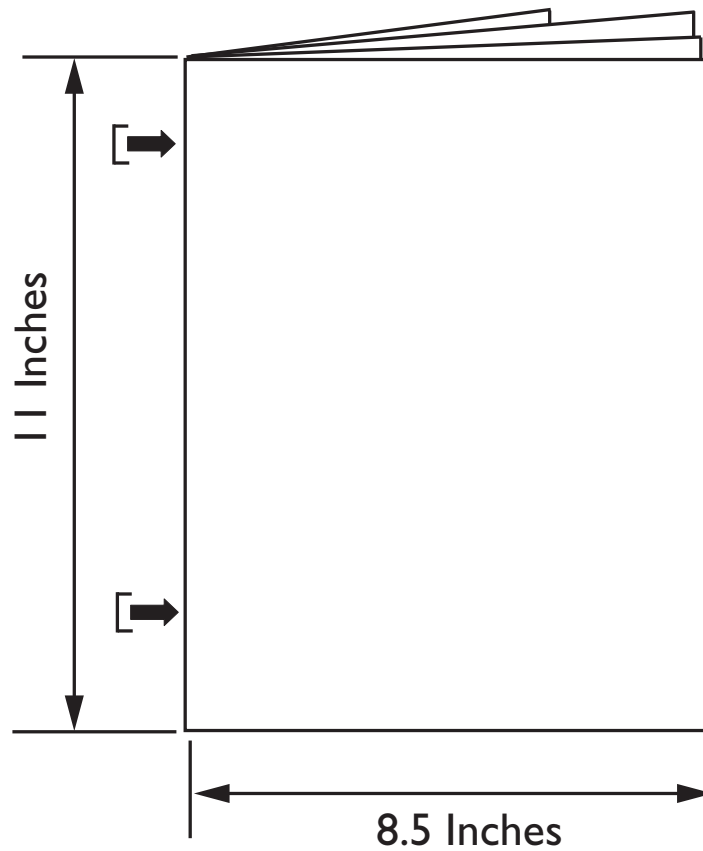

DO NOT scale the artwork for printing.
It has been scaled for proper scaling of parts.

Revisions.

A. Released for Production. 6.30.2025. JAN.



The Sova Company™
5216 Portside Dr, Medina OH 44256 USA • PH: +1 234.400.0707
www.ChooseSova.com

Origin Vertical Surface Mount With EZ Mount™ Backer Plate

10VS0201

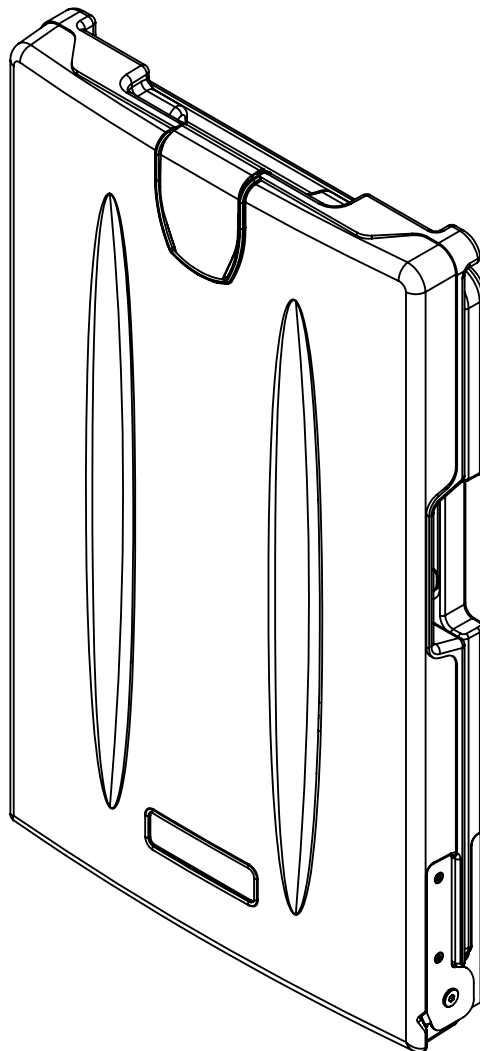

AB20559A

IMPORTANT. RETAIN FOR FUTURE REFERENCE. READ CAREFULLY.

⚠ WARNING

- Failure to follow these warnings and the installation instructions could result in serious injury or death.
- Read all instructions before installing diaper changing station. Keep these instructions. DO NOT discard.
- All four (4) mounting locations MUST be used for safe installation. The lower holes provide reinforced installation through the metal bracket.
- The diaper changing station is no stronger than the anchors or walls to which they are attached and, therefore, MUST be firmly secured in order to support the weight they are intended to support. Contact an architect or building contractor if any questions.
- Child should never be left unattended.
- Avoid serious injury from falling or sliding out. Always use restraint system.
- Adding excessive weight such as parcels, packages, or accessories to the unit or to the bag hooks that exceed the total weight limit of 50 pounds (22.7 kg) may cause the unit to be unstable or may cause a hazardous unstable condition to exist.
- A minimum of 1 stud must be used while mounting the changing station. If 1 stud can not be used for either side, additional hardware blocking is required.
- In addition to the backer plate, mount the changing station using the (4) supplied mounting screws. The backer plate alone is NOT a secure attachment method.

OPERATION

- Rotate base downward. Place child on top of the changing surface. Use restraint system as described below. After child has been changed, remove restraint system and rotate base back up against the wall.

USE OF RESTRAINT SYSTEM

- Place child so restraint strap is located at abdomen. Rotate top of buckle upward and insert strap in buckle. Pull strap through buckle until snug against child. Rotate top of buckle downward to lock the strap into place. Slide red locking tab over top of the buckle (Fig. a). Reverse steps to loosen strap.

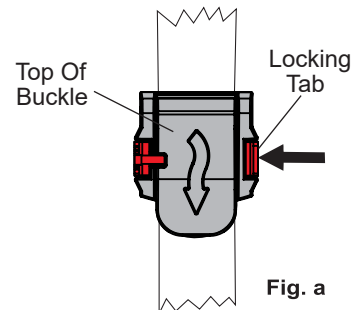

MAINTENANCE AND CLEANING

- Check all hardware and components monthly or as required to ensure hardware is tight and there are no missing or damaged components. Take unit out of service if any component is missing or damaged and contact customer service to order replacement parts. Do not substitute parts. For replacement parts, contact customer service at +1-234-400-0707.
- Clean by using a damp cloth with mild soap or mild multi-purpose cleaner. Do not use any strong chemical cleaners or cleaning agents that may be hazardous to children.

A.D.A Compliance:

306.3 Knee Clearance
307.2 Maximum Protruding Objects
308.2 Forward Reach
308.3 Side Reach
309.4 Operation
902.3 Work Surface



Compliant when properly installed

5216 Portside Dr.
Medina Ohio 44256 USA
Telephone: +1 234.400.0707
www.ChooseSova.com

IMPORTED BY:
The Sova Company™
30 Casebridge Court
Scarborough, ON M1B 3M5 CAN
+1 234.400.0707

TOOLS REQUIRED

IMPORTANT: Steel stud or block wall construction requires additional hardware. Please contact a professional contractor or architect for assistance in determining suitable hardware.

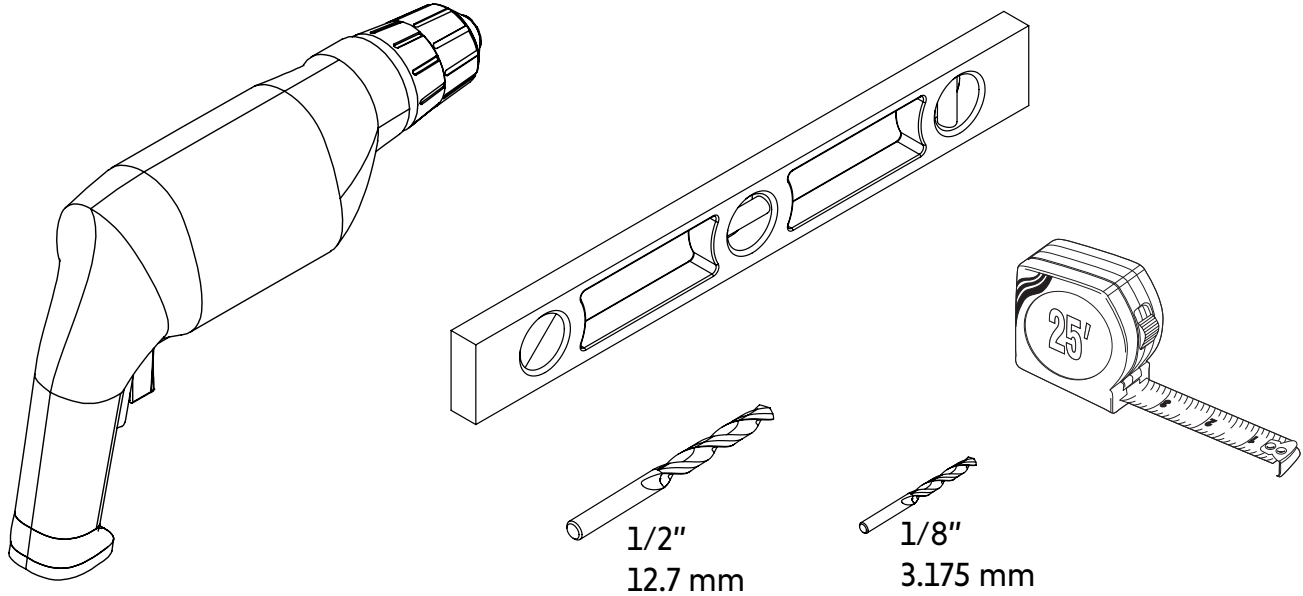

AB20556_G37

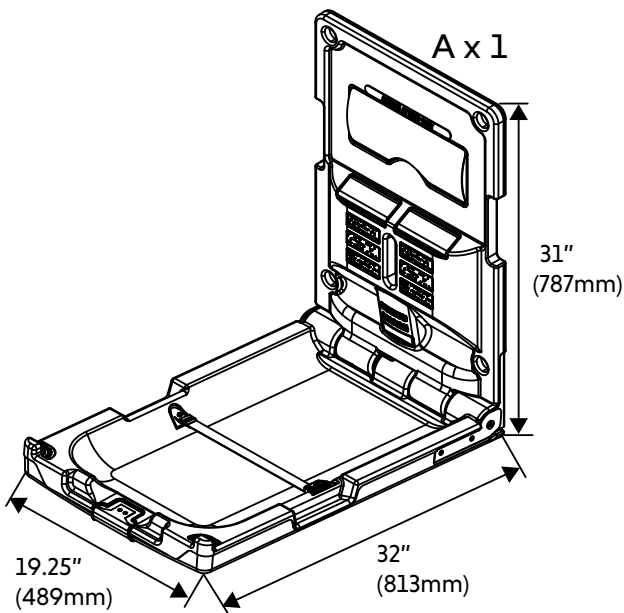

C x 1

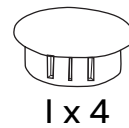

For Wood Studs:

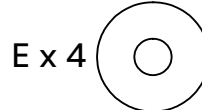
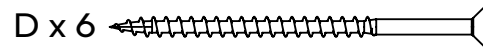

For Toggle Anchors:

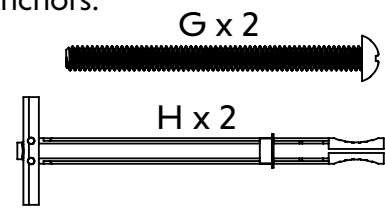

B x 1

AB20558_G5

PREINSTALLATION GUIDE 1

The backer plate is designed to enhance the attachment method by easing single person installation and provides extra strength compare to unit only installation.

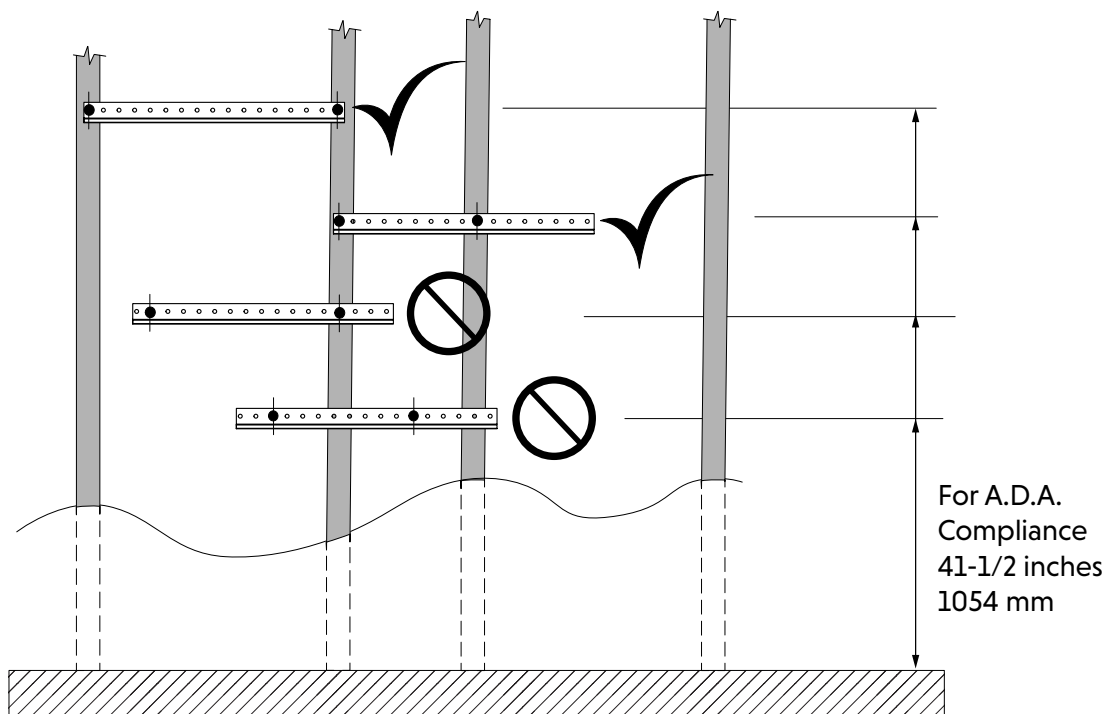
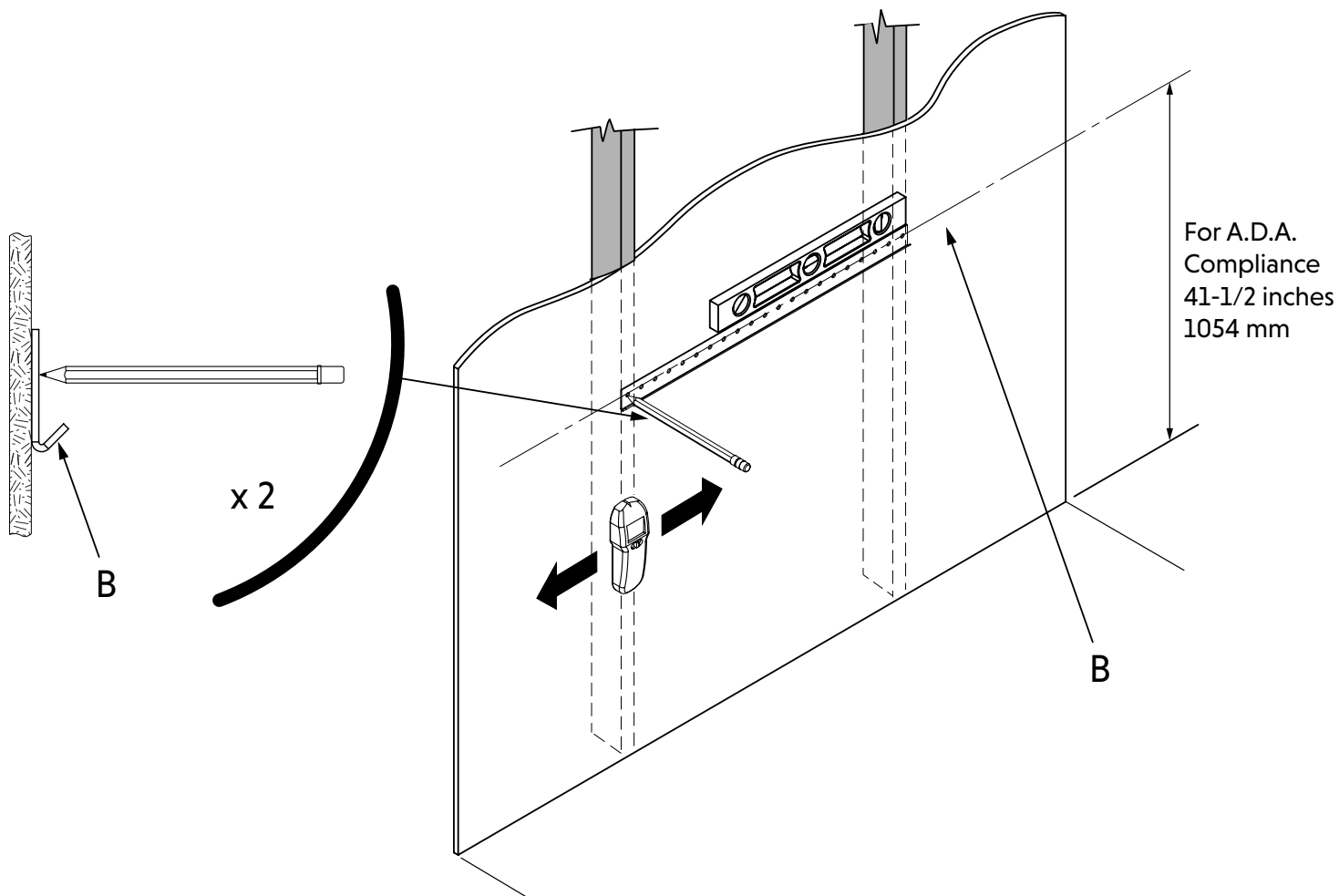

AB20558_G2

PREINSTALLATION GUIDE 2

B x 1

D x 2

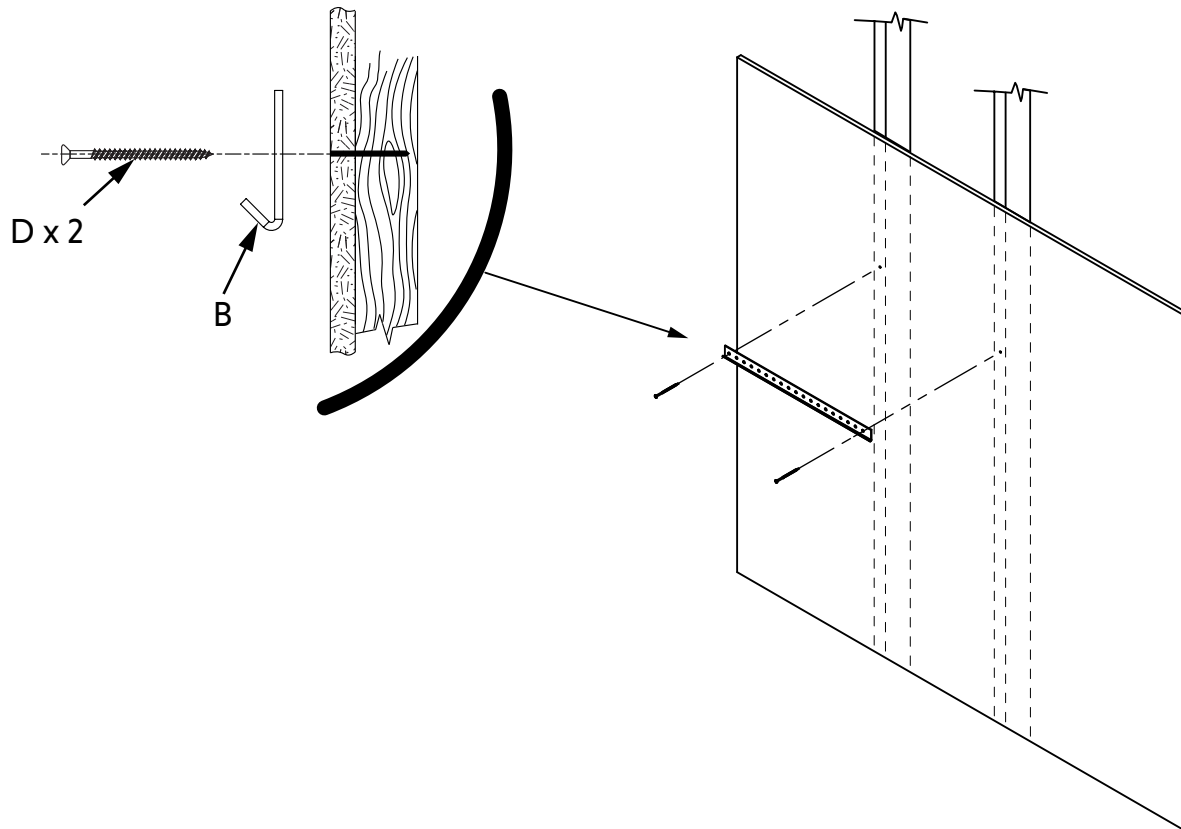

AB20559_G5

PREINSTALLATION GUIDE 3

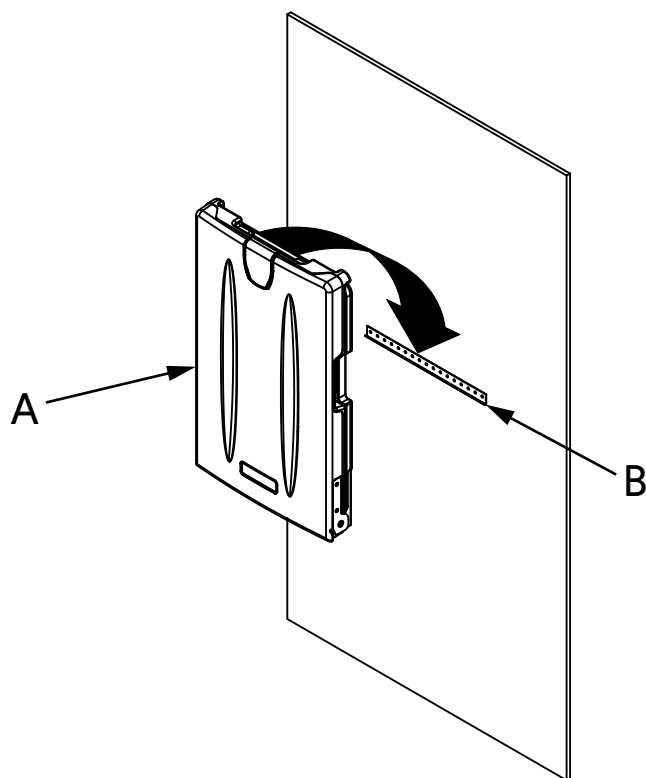

AB20558_G13

PREINSTALLATION GUIDE 4

IMPORTANT: A minimum of 1 stud must be used while mounting the changing station. If 1 stud can not be used for either side, additional hardware blocking is required. Please contact an architect or professional contractor to make sure the blocking is adequate and complies with building codes.

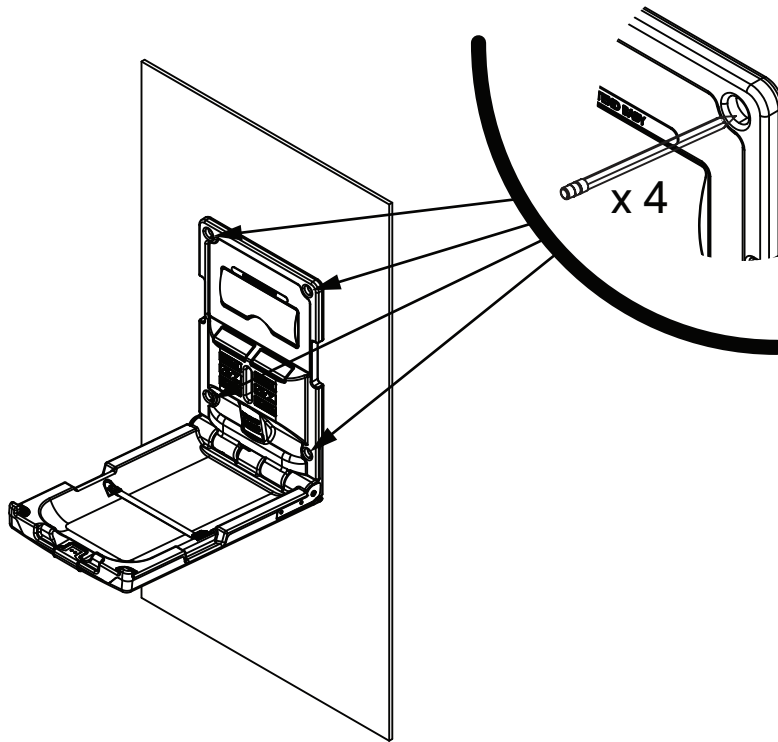

AB20558_G25

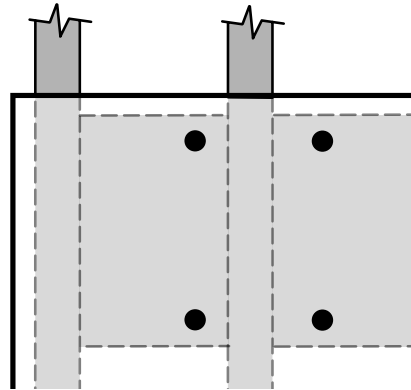
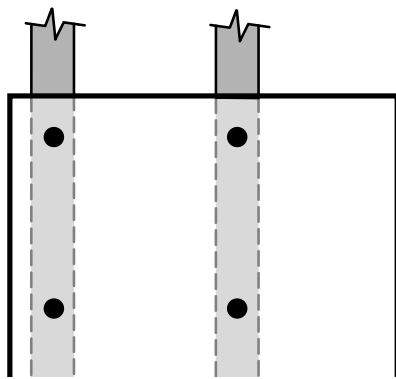

OPTION 1 - PAGE 7

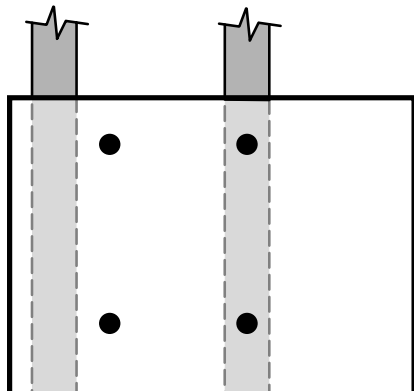

OPTION 2 - PAGE 11

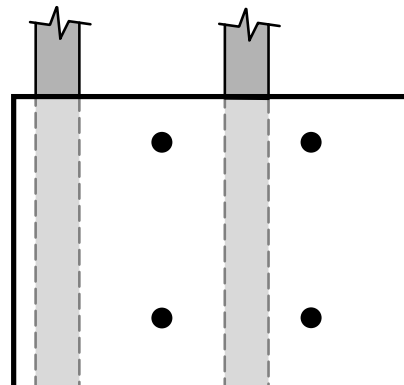

AB20559_G2

OPTION 1

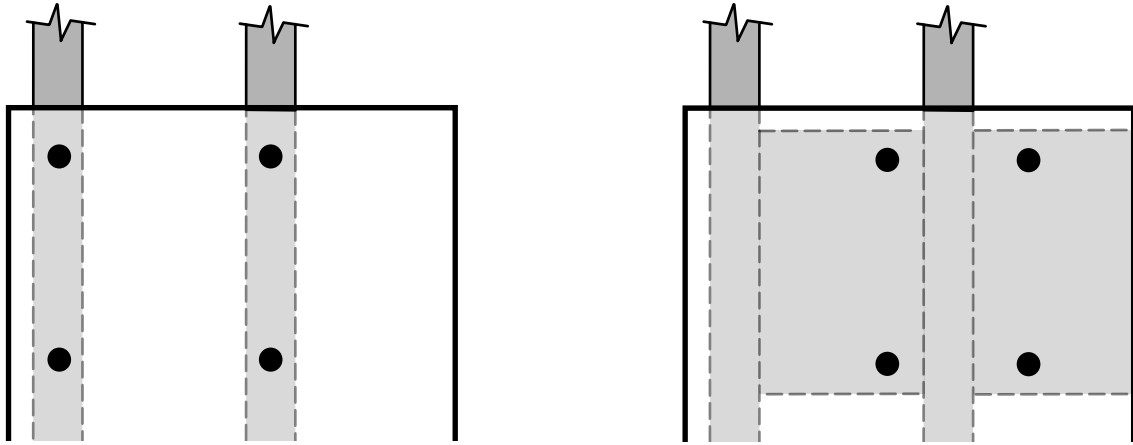

AB20559_G3

1

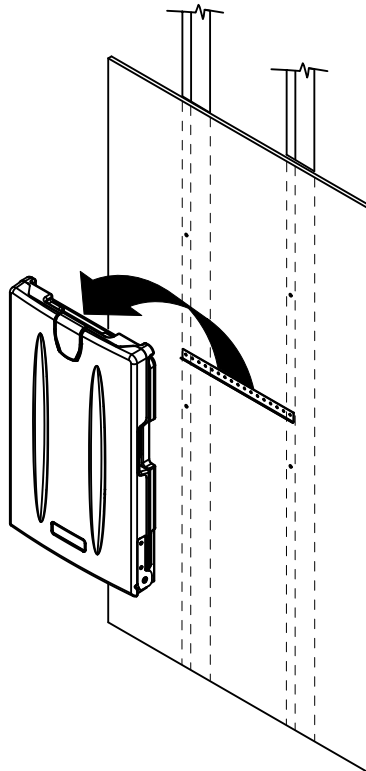

AB20558_G28

2

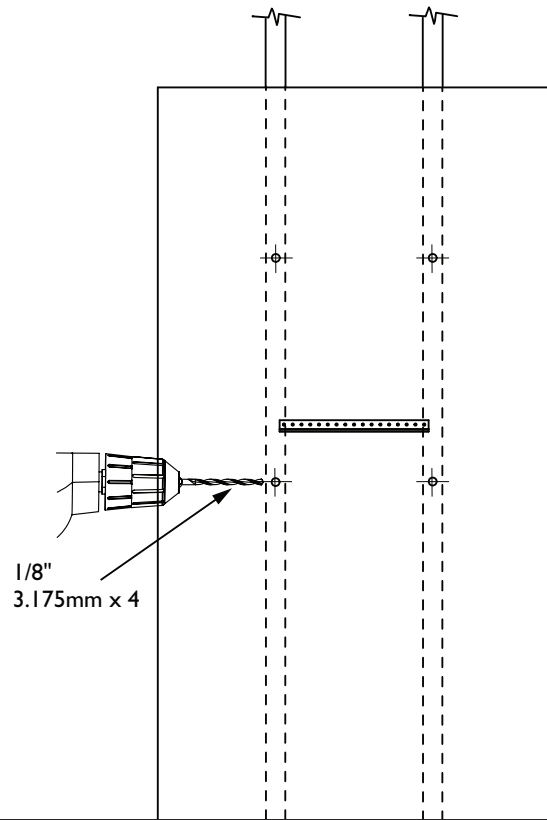

AB20558_G22

3

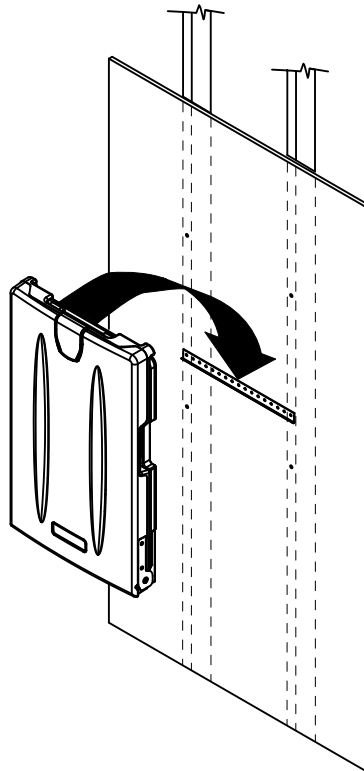

AB20558_G27

4

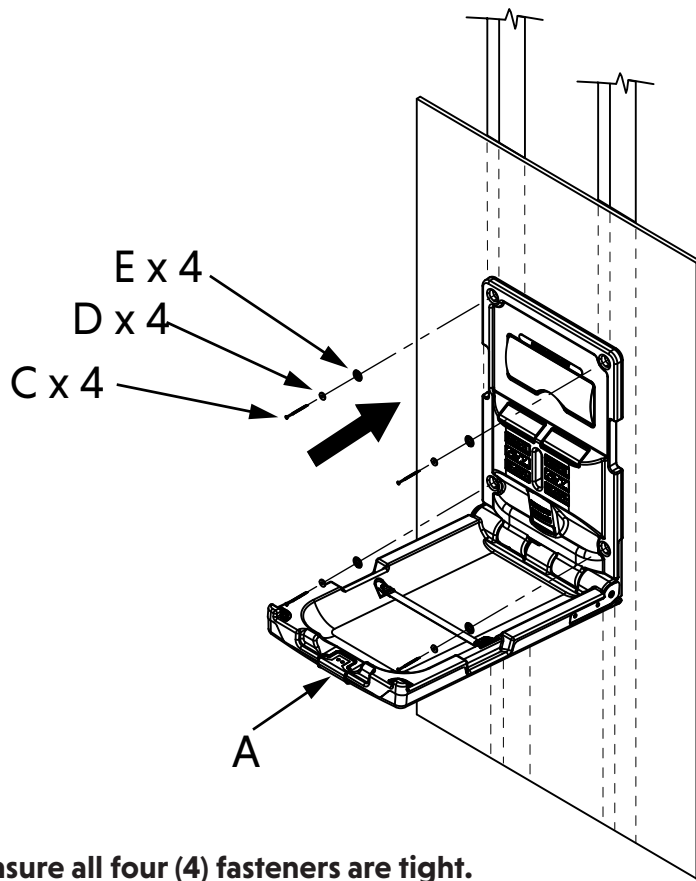

A x 1
C x 4
D x 4
E x 4

IMPORTANT: Ensure all four (4) fasteners are tight.

AB20558_G10

5

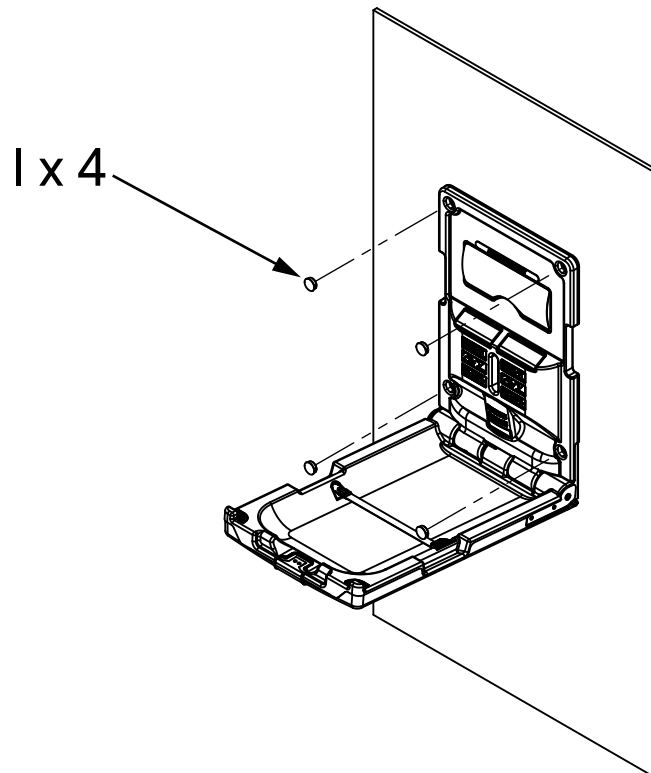

I x 4

AB20558_G12

WALL PLACARD

C x 1

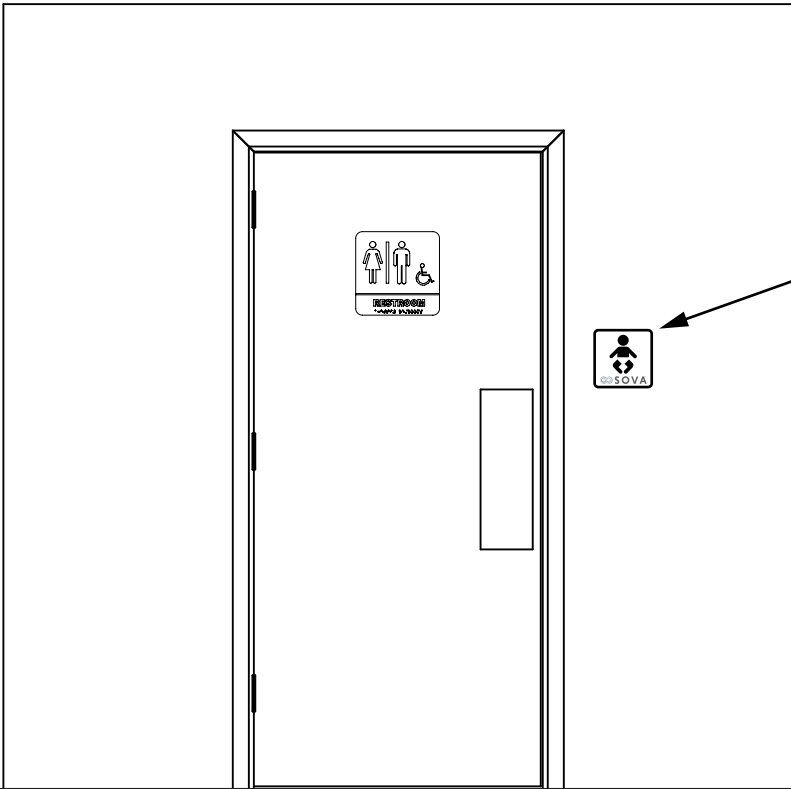

AB20572_G11

OPTION 2

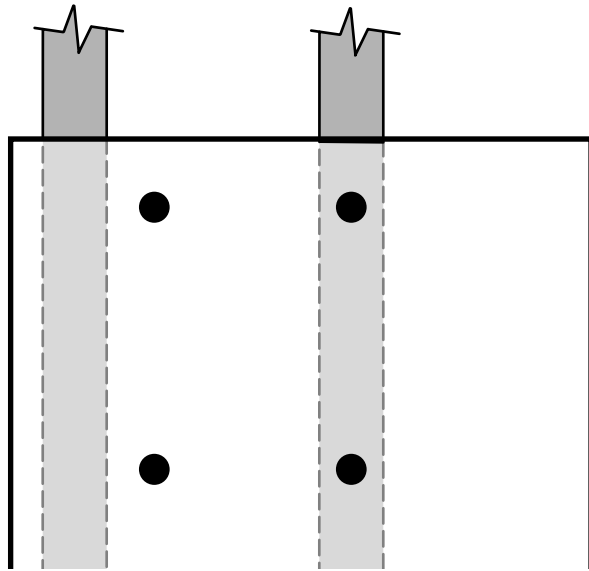

AB20559_G4

1

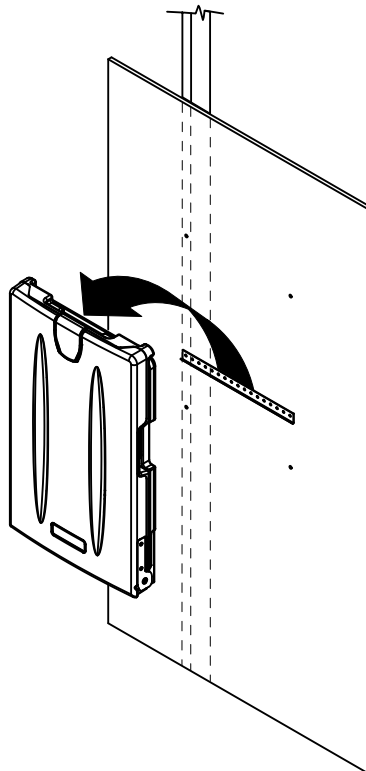

AB20558_G29

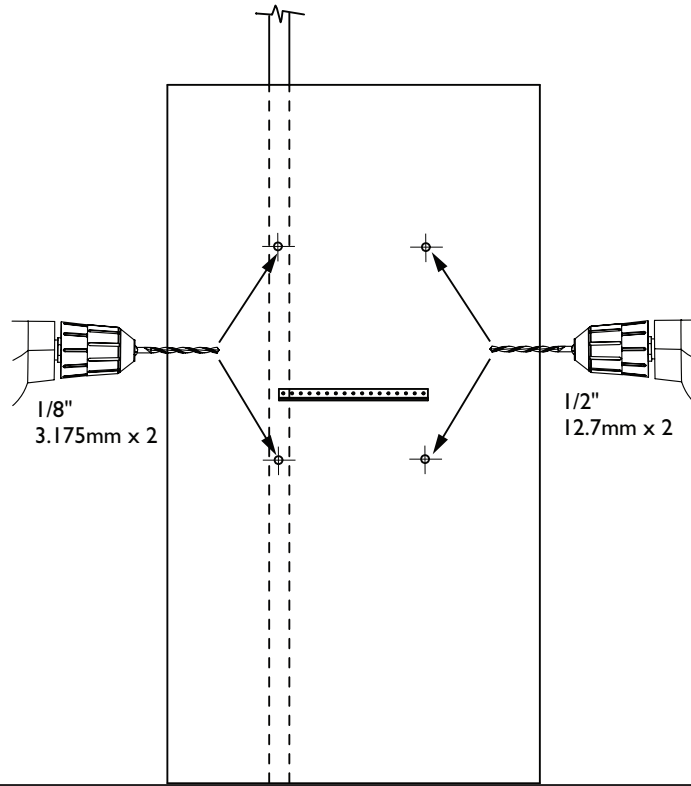

AB20558 G20

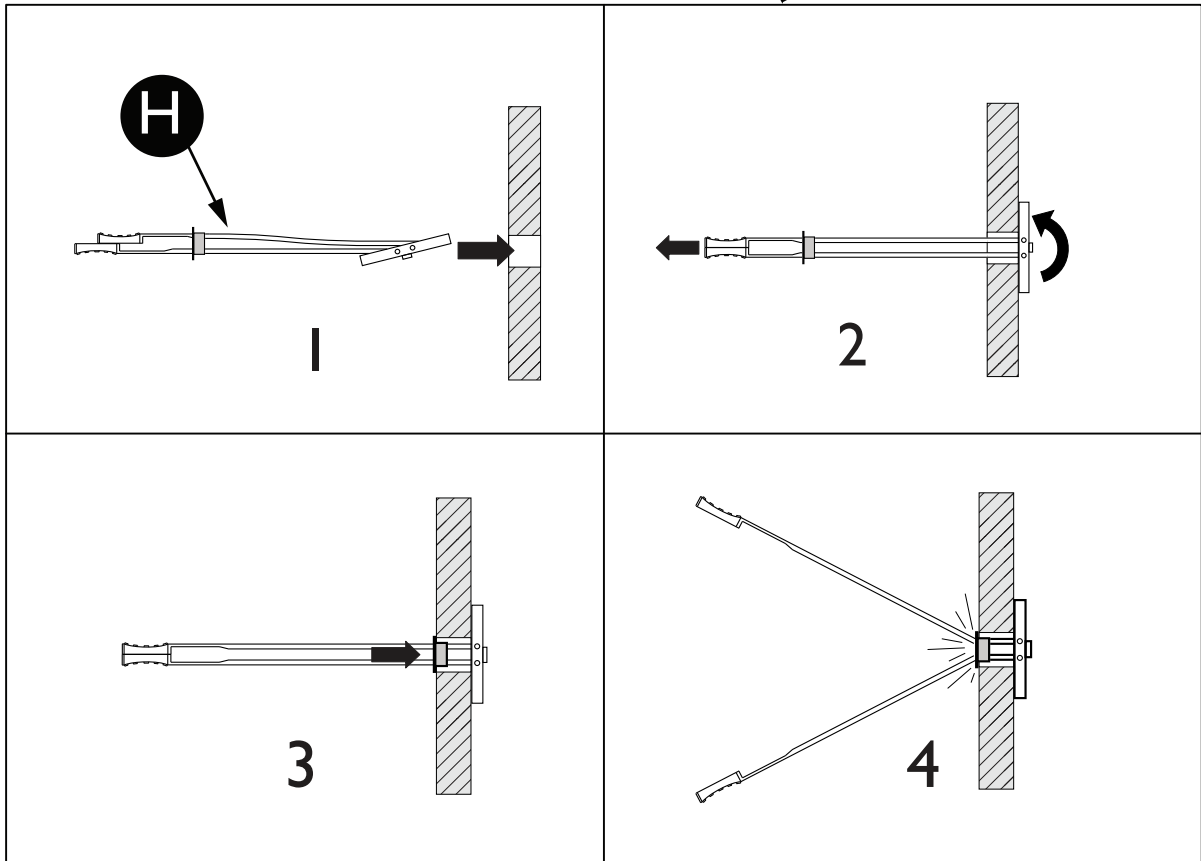
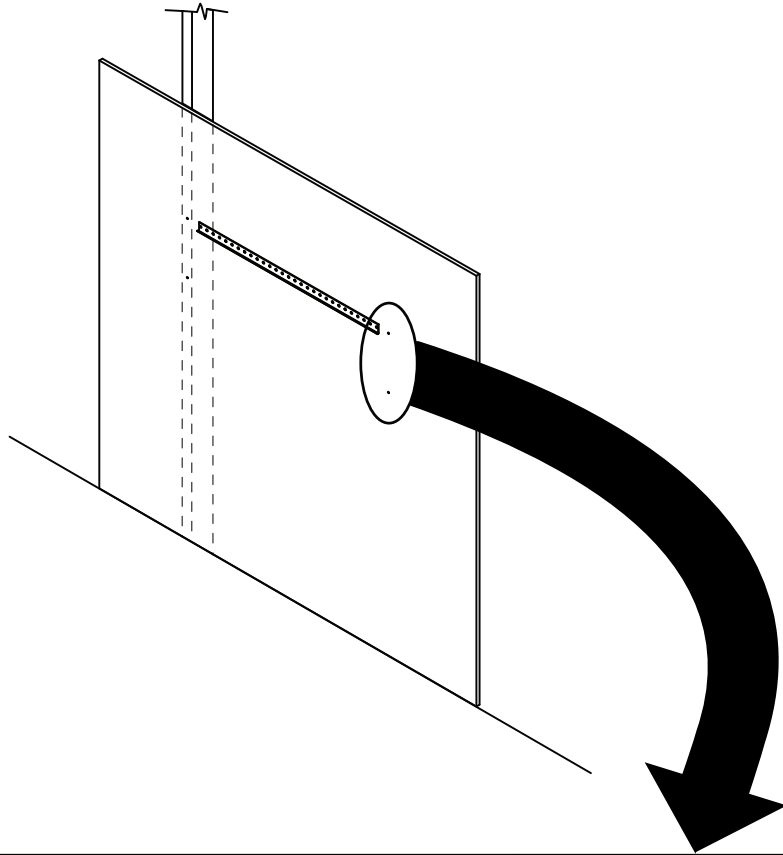

4

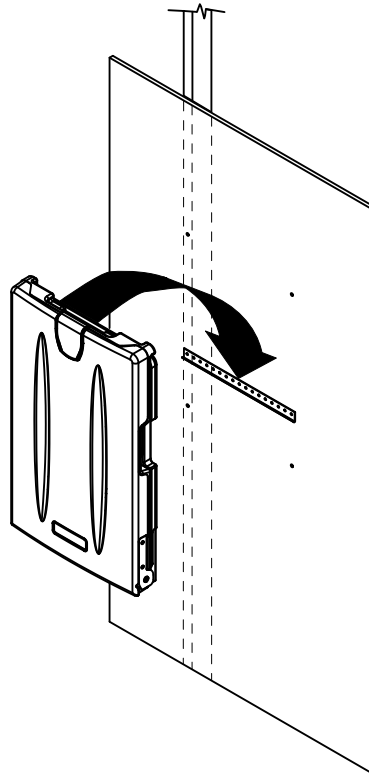

AB20558_G26

5

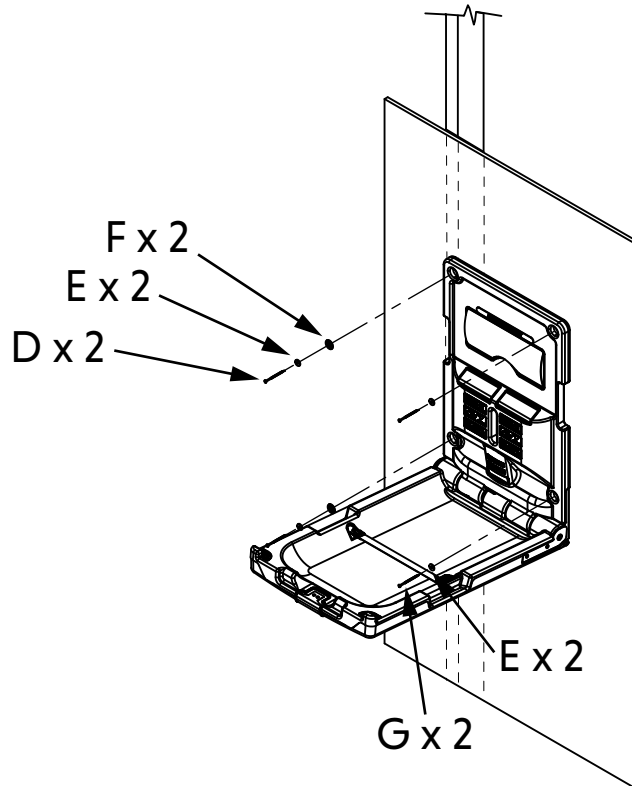

D x 2
E x 4
F x 2
G x 2

IMPORTANT: Ensure all four (4) fasteners are tight.

AB20558_G11

1 x 4

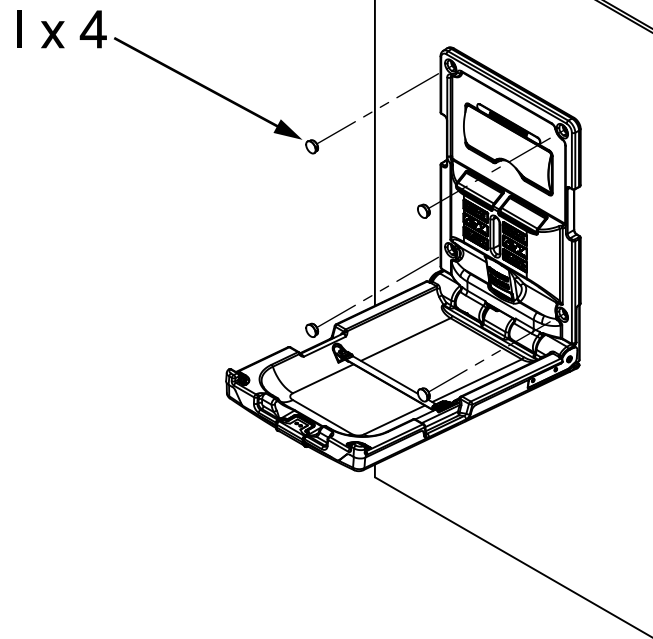

AB20558_G12

WALL PLACARD

C x 1

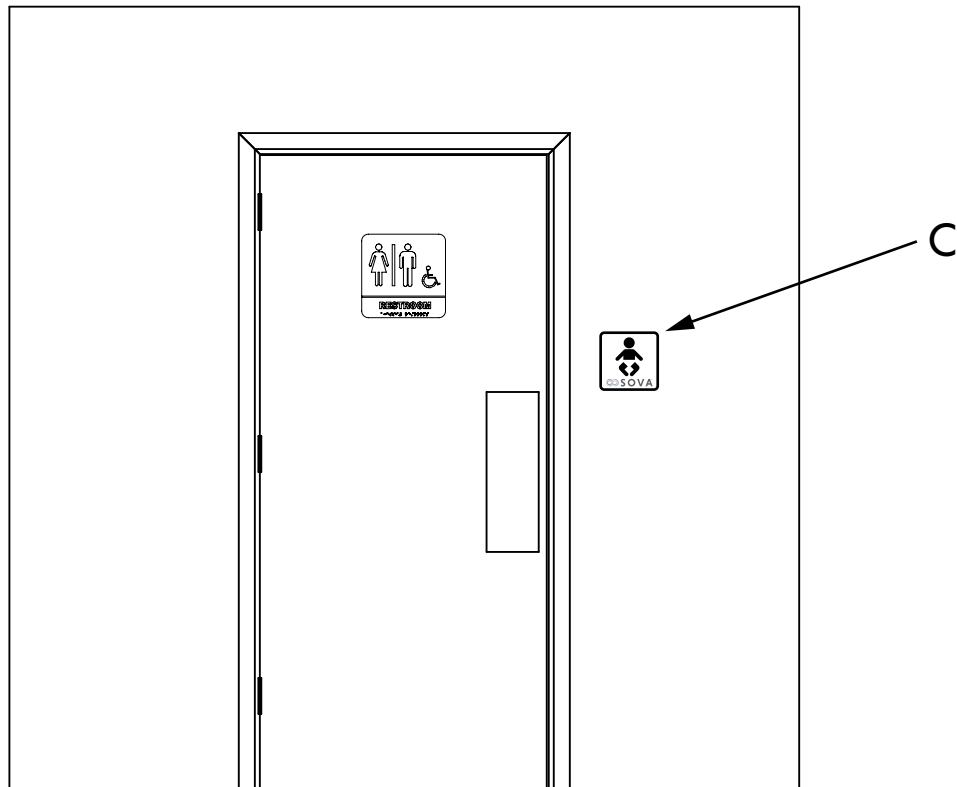

AB20572_G11

Montaje Vertical de Origen con placa trasera EZ Mount™ 10VS0201

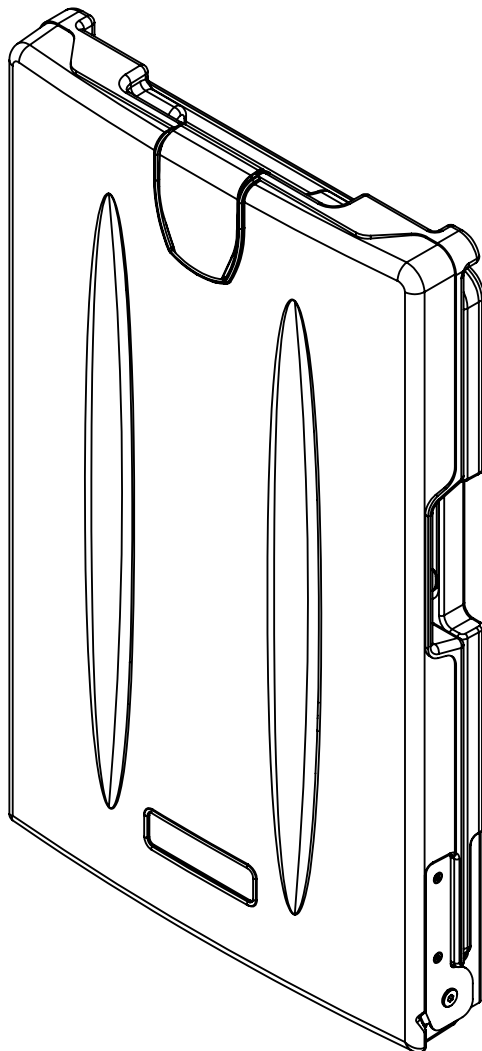

IMPORTANTE. CONSERVAR PARA FUTURAS REFERENCIAS. LEE CUIDADOSAMENTE.

⚠ ADVERTENCIA

- El incumplimiento de estas advertencias y las instrucciones de instalación puede resultar en lesiones graves o muerte.
- Lea todas las instrucciones antes de instalar la estación de cambio de pañales. Conserve estas instrucciones. NO las deshaga.
- Se deben utilizar los cuatro (4) puntos de montaje para una instalación segura. Los agujeros inferiores permiten una instalación reforzada a través del soporte de metal.
- La estación de cambio de pañales no es más fuerte que los anclajes o las paredes a las que está sujeta y, por lo tanto, DEBE estar firmemente asegurada para poder soportar el peso que se supone que debe soportar. Contacte a un arquitecto o contratista de construcción si tiene alguna pregunta.
- El niño nunca debe ser dejado sin supervisión.
- Evite lesiones graves por caídas o deslizamientos. Siempre use el sistema de sujeción.
- Agregar peso excesivo, como paquetes, bultos o accesorios, a la unidad o a los ganchos de la bolsa que excedan el límite de peso total de 50 libras (22.7 kg) puede hacer que la unidad sea inestable o puede causar que exista una condición inestable peligrosa.
- Se debe utilizar un mínimo de 1 viga al instalar la estación de cambio. Si no se puede utilizar 1 viga en ninguno de los lados, se requiere hardware de soporte adicional.
- Además de la placa de respaldo, monte la estación de cambio utilizando los (4) tornillos de montaje suministrados. La placa de respaldo por sí sola NO es un método de sujeción seguro.

OPERACIÓN

- Gire la base hacia abajo. Coloque al niño sobre el cambiador. Use el sistema de sujeción como se describe a continuación. Después de cambiar al niño, retire el sistema de sujeción y gire la base hacia la pared.

USO DEL SISTEMA DE SUJECIÓN

- Coloque al niño de forma que la correa de sujeción quede a la altura del abdomen. Gire la parte superior de la hebilla hacia arriba e inserte la correa. Pase la correa por la hebilla hasta que quede ajustada contra el niño. Gire la parte superior de la hebilla hacia abajo para bloquear la correa. Deslice la pestaña roja de bloqueo sobre la parte superior de la hebilla (Fig. a). Invierta los pasos para aflojar la correa.

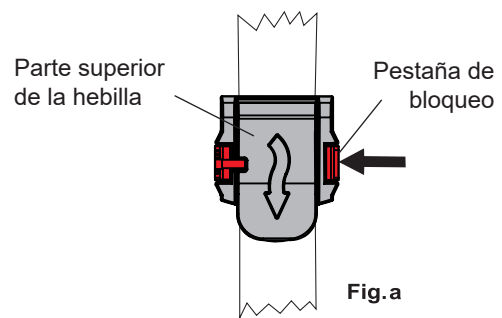

MANTENIMIENTO Y LIMPIEZA

- Revise todo el hardware y los componentes mensualmente o según sea necesario para asegurarse de que el hardware esté ajustado y no haya componentes faltantes o dañados. Retire la unidad de servicio si falta o está dañado algún componente y comuníquese con el servicio al cliente para pedir piezas de repuesto. No sustituya piezas. Para piezas de repuesto, comuníquese con el servicio al cliente al +1-234-400-0707.
- Limpia utilizando un paño húmedo con jabón suave o un limpiador multiusos suave. No uses limpiadores químicos fuertes ni agentes de limpieza que puedan ser peligrosos para los niños.

Cumplimiento de la A.D.A.:

306.3 Despeje de la rodilla
307.2 Objetos Protruyentes Máximos
308.2 Alcance hacia adelante
308.3 Alcance Lateral
309.4 Operación
902.3 Superficie de trabajo



5216 Portside Dr.
Medina Ohio 44256 USA
Teléfono: +1 234.400.0707
www.ChooseSova.com

IMPORTADO POR:
The Sova Company™
30 Casebridge Court
Scarborough, ON M1B 3M5 CAN
+1 234.400.0707

Cumple con las normas cuando está correctamente instalado

HERRAMIENTAS NECESARIAS

IMPORTANTE: La construcción con paredes de acero o bloques requiere hardware adicional. Por favor, contacta a un contratista o arquitecto profesional para obtener ayuda en la determinación del hardware adecuado.

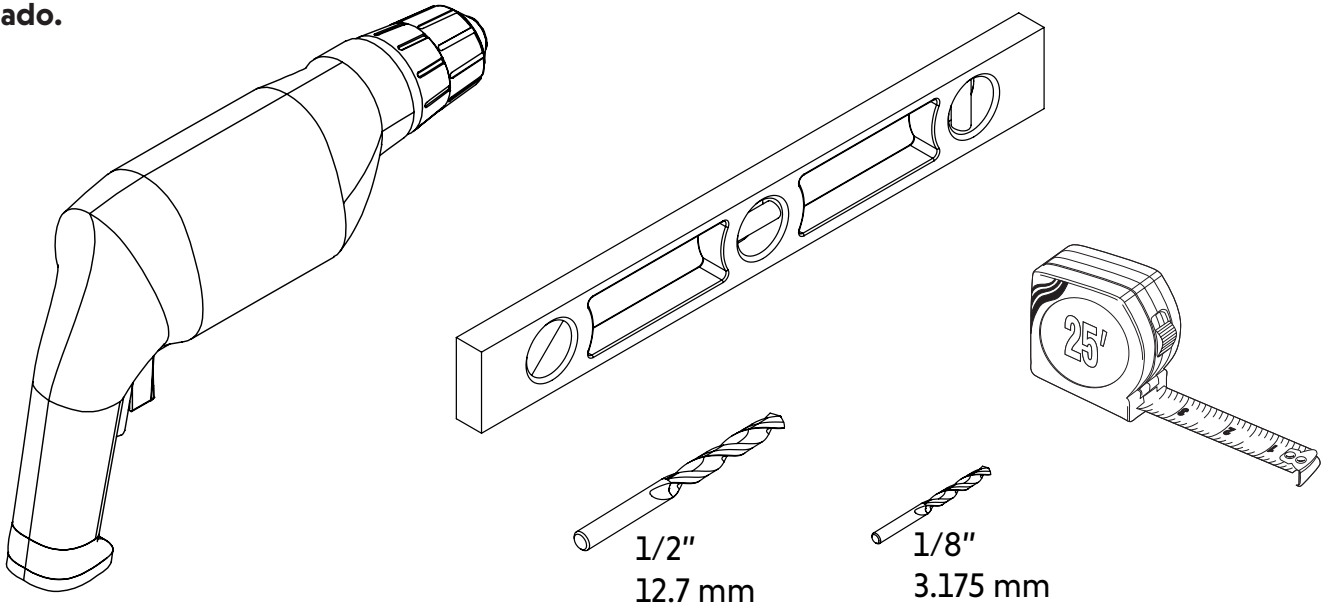

AB20556_G37

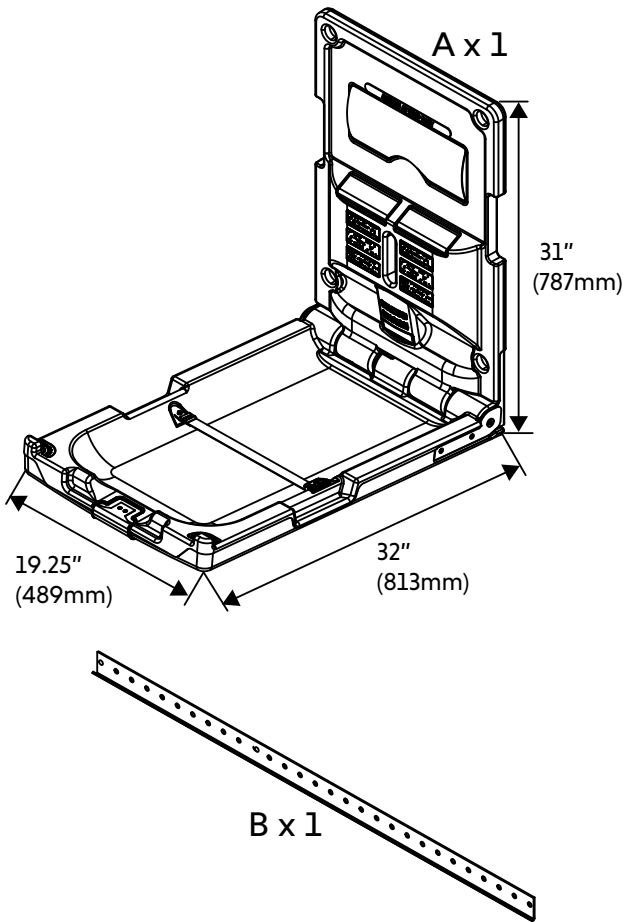

C x 1

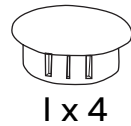

I x 4

Para montantes de madera:

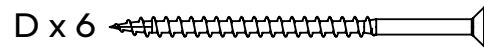

E x 4

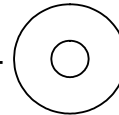

F x 4

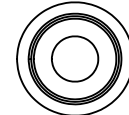

Para Alternar Anclajes:

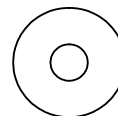

E x 4

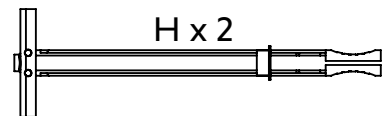

AB20558_G5

GUÍA DE PREINSTALACIÓN 1

La placa de soporte está diseñada para mejorar el método de instalación al facilitar la instalación de una sola persona y proporciona una mayor resistencia en comparación con la instalación de solo la unidad.

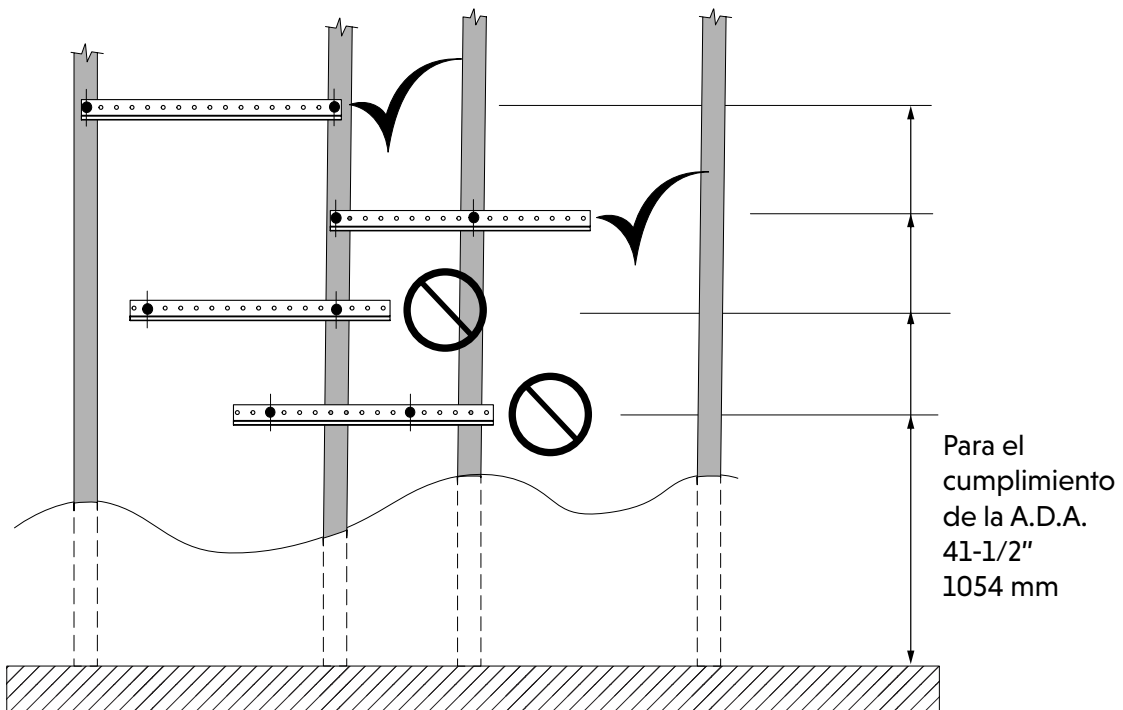
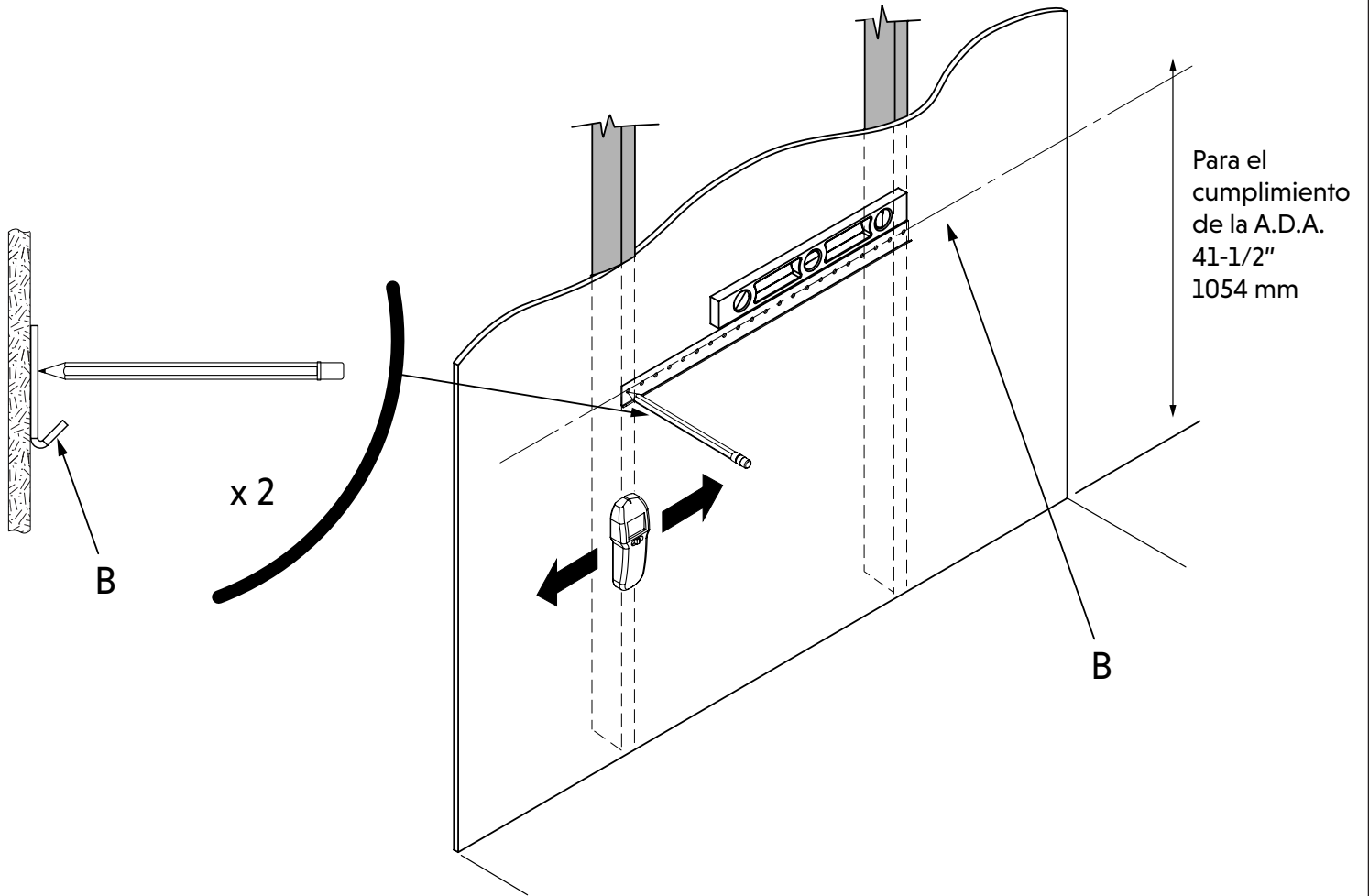

AB20558_G2

GUÍA DE PREINSTALACIÓN 2

B x 1

D x 2

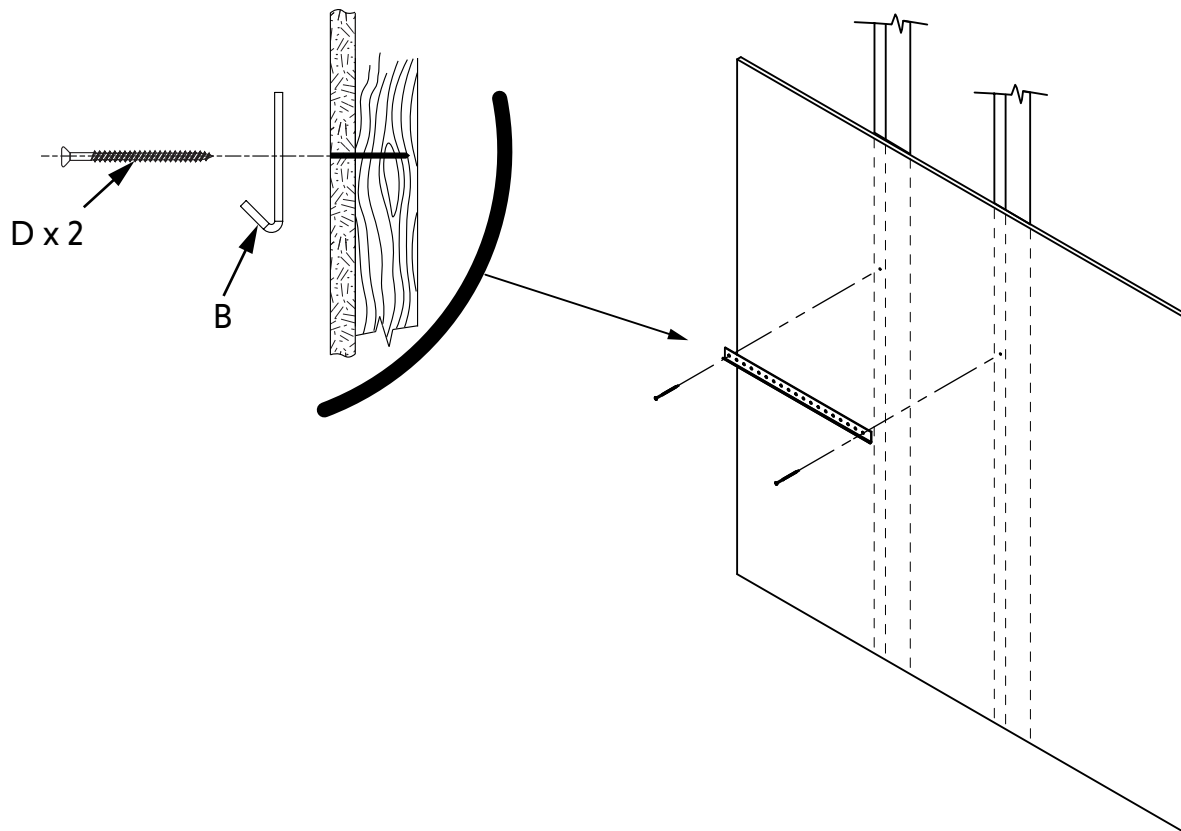

AB20559_G5

GUÍA DE PREINSTALACIÓN 3

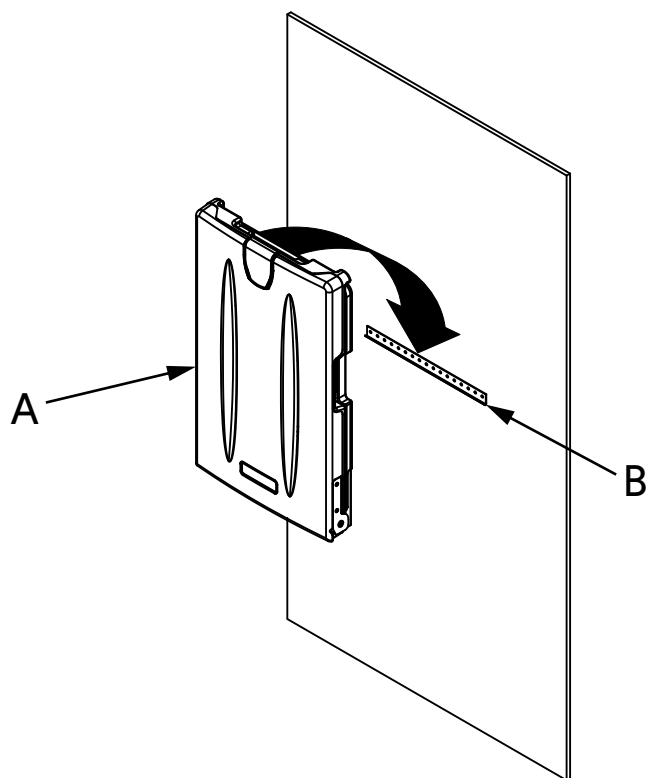

AB20558_G13

GUÍA DE PREINSTALACIÓN 4

IMPORTANTE: Se debe utilizar un mínimo de 1 viga al montar la estación de cambio. Si no se puede utilizar 1 viga en ninguno de los lados, se requiere un bloqueo adicional. Comuníquese con un arquitecto o contratista profesional para asegurarse de que el bloqueo sea adecuado y cumpla con los códigos de construcción.

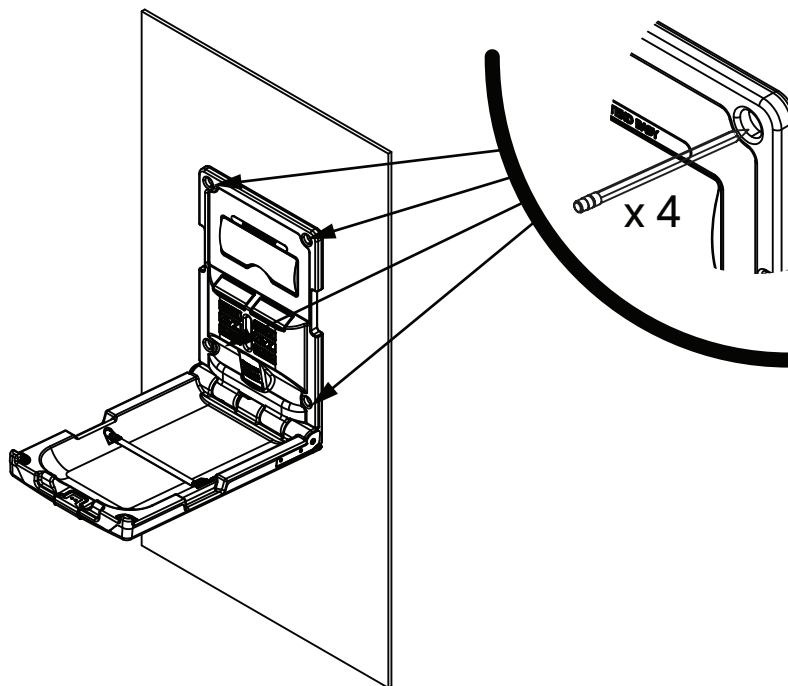

AB20558_G25

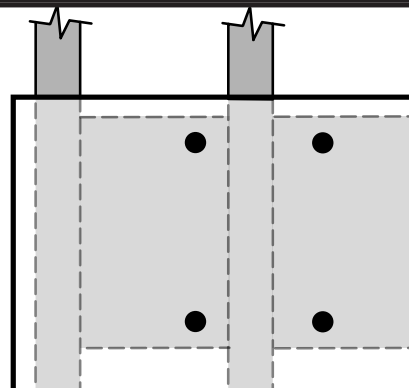
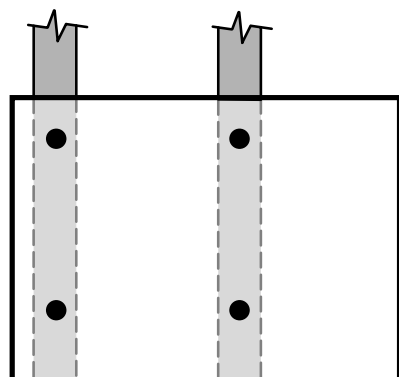

OPCIÓN 1 - PÁGINA 22

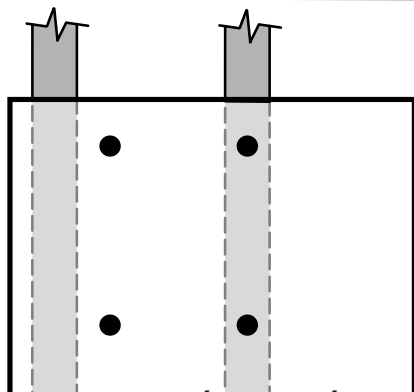

OPCIÓN 2 - PÁGINA 26

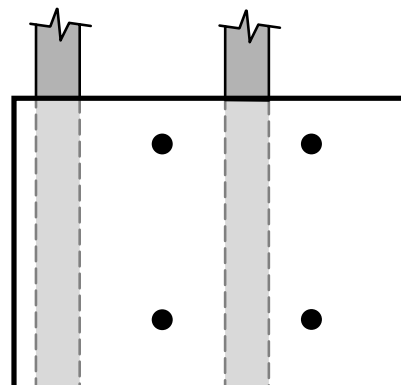

AB20559_G2

OPCIÓN 1

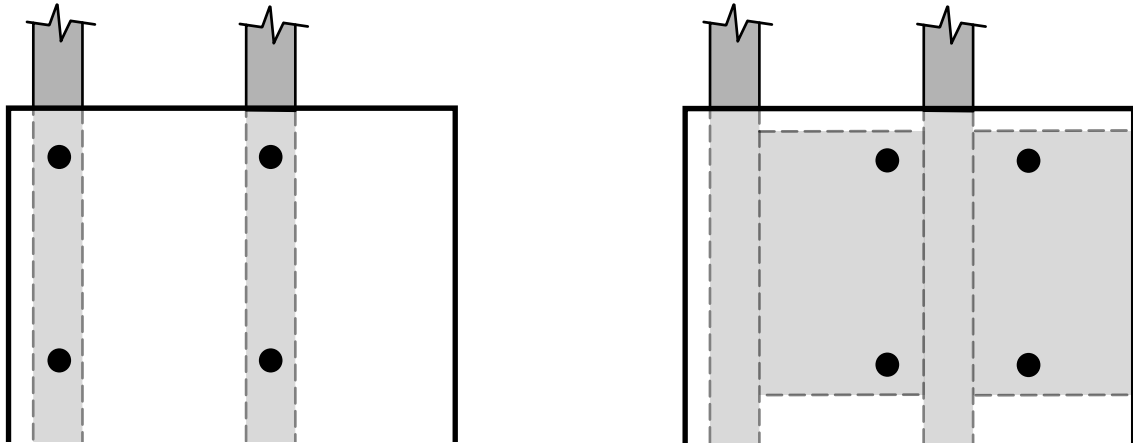

AB20559_G3

1

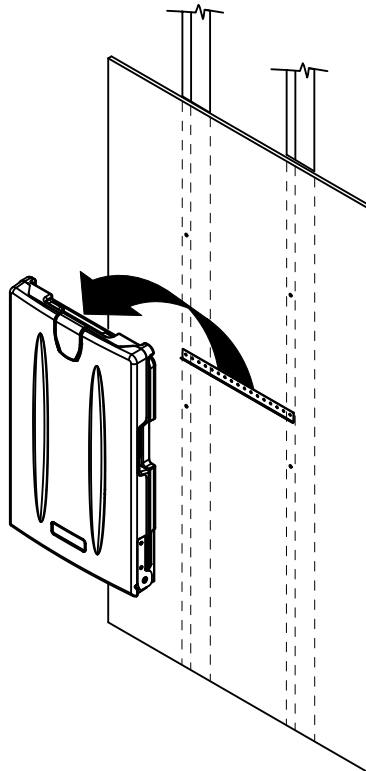

AB20558_G28

2

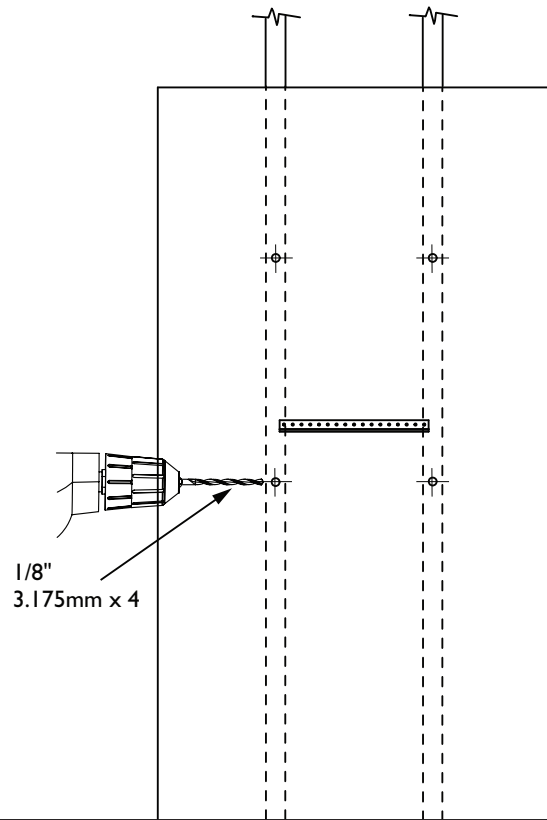

AB20558_G22

3

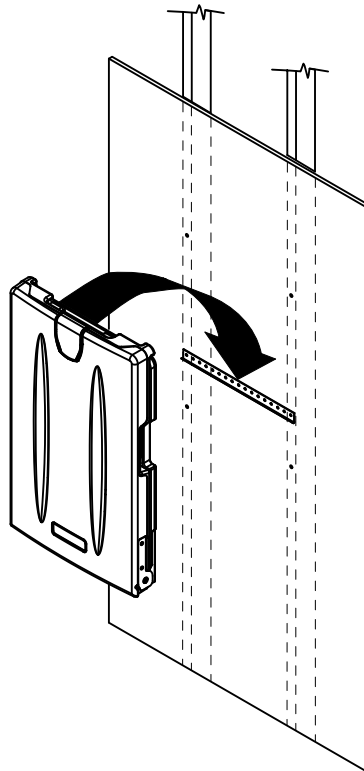

AB20558_G27

4

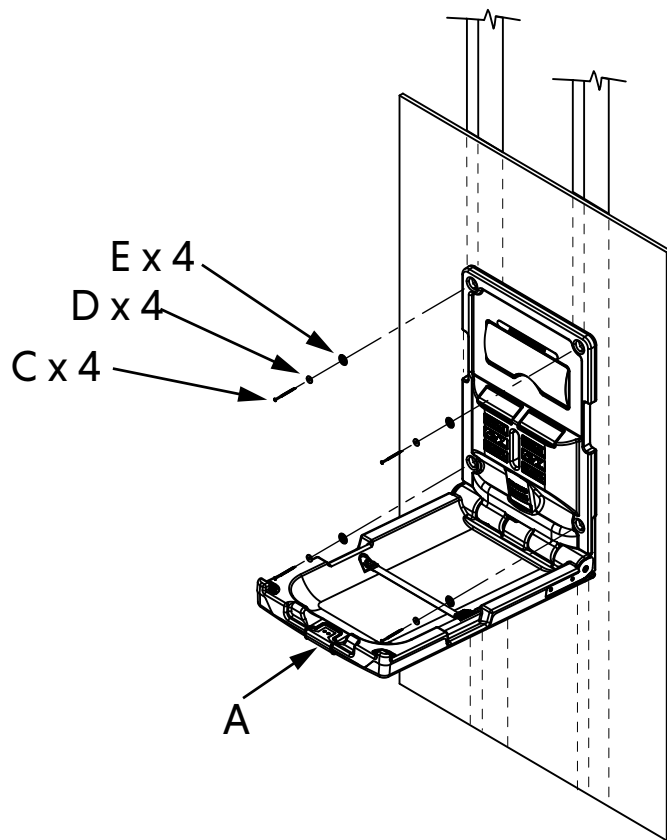

A x 1
C x 4
D x 4
E x 4

IMPORTANTE: Asegúrese de que los cuatro (4) sujetadores estén bien apretados.

AB20558_G10

5

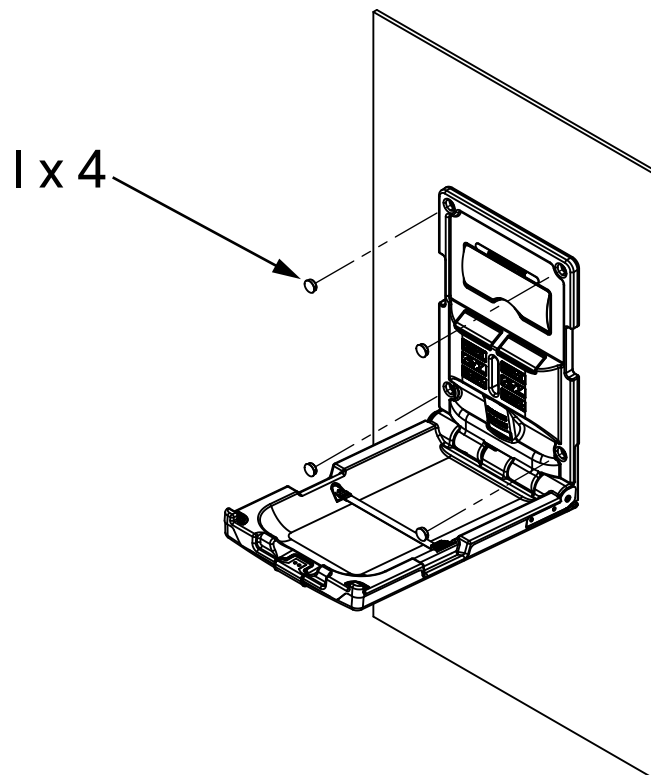

I x 4

AB20558_G12

PLACARD DE PARED

C x 1

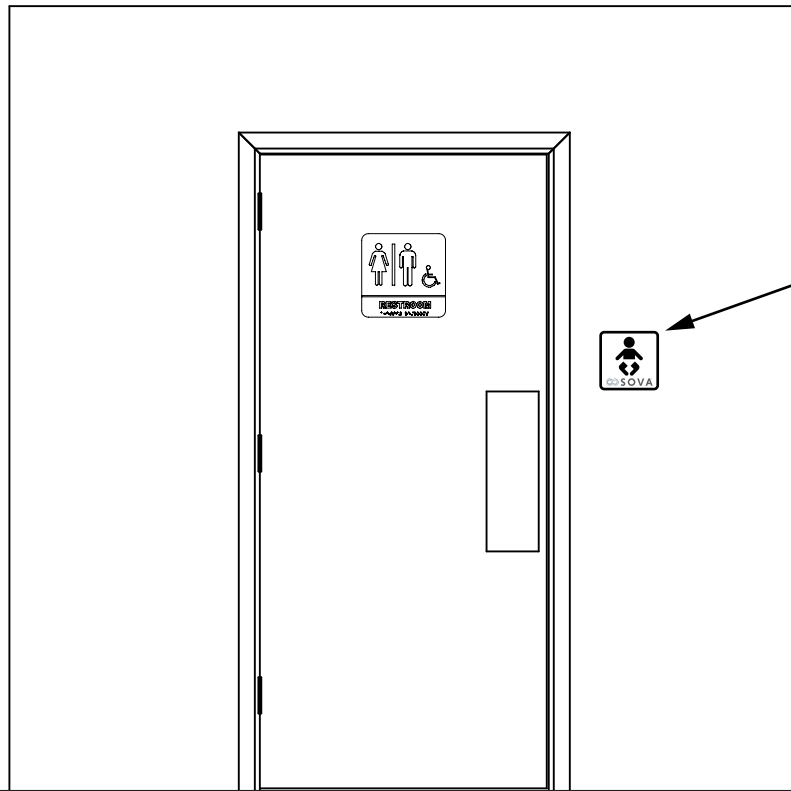

AB20572_G11

OPCIÓN 2

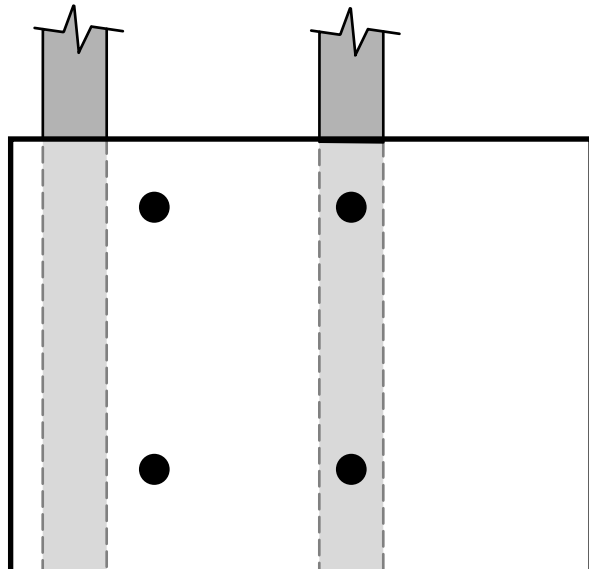

AB20559_G4

1

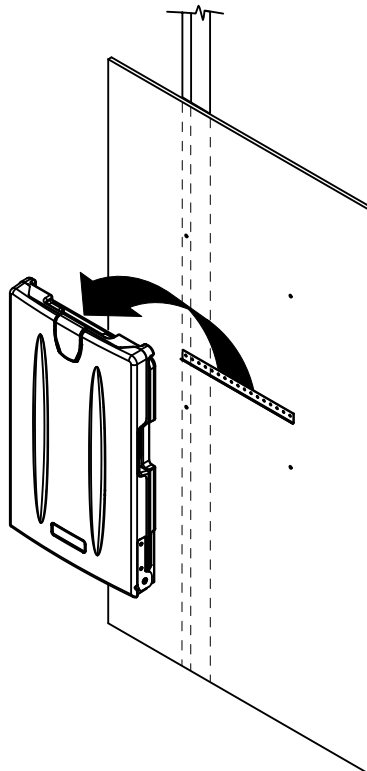

AB20558_G29

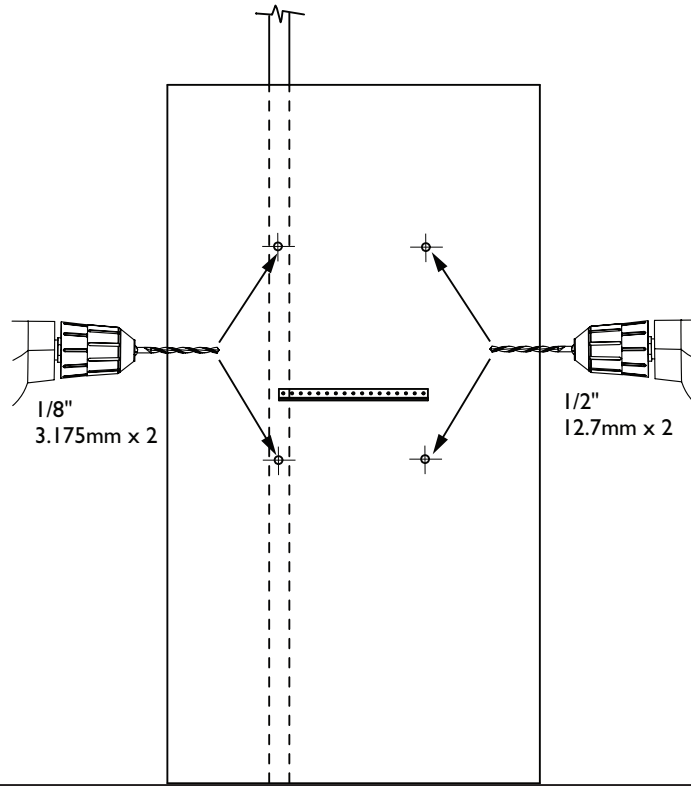

AB20558 G20

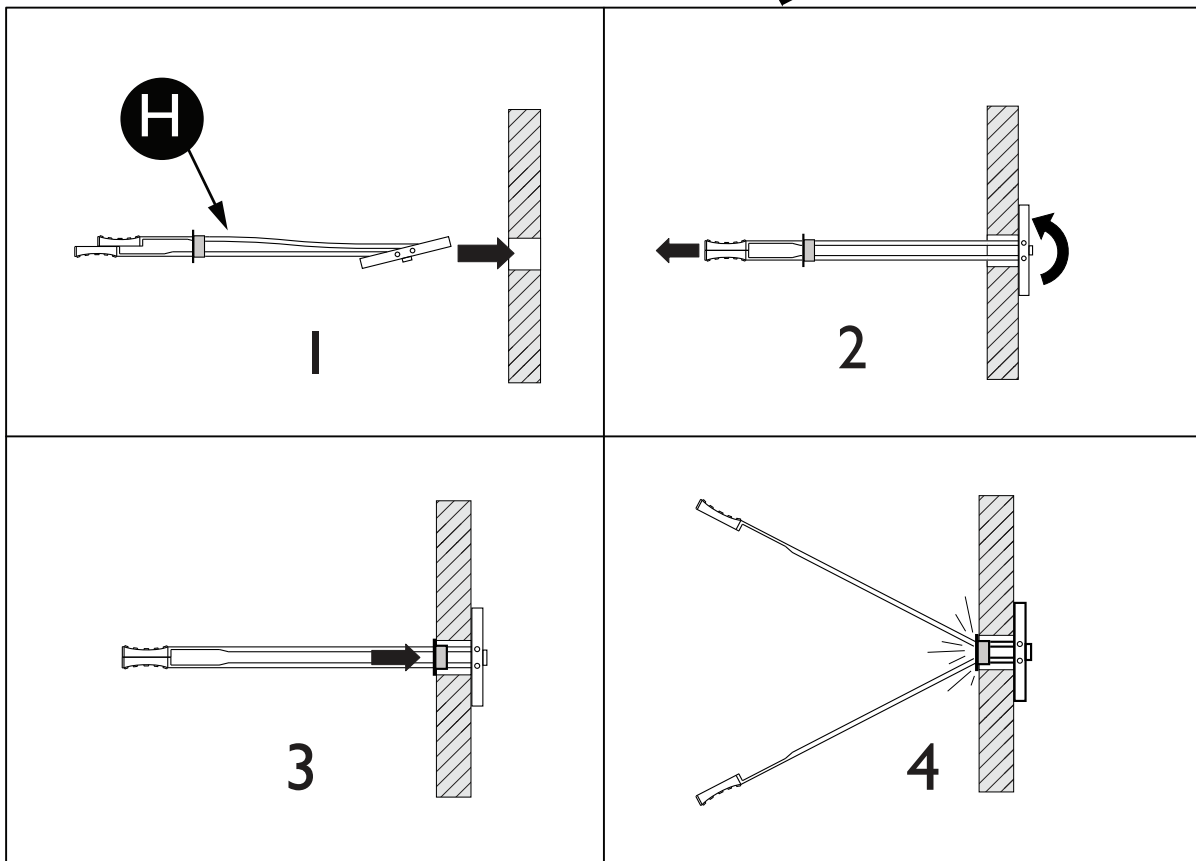
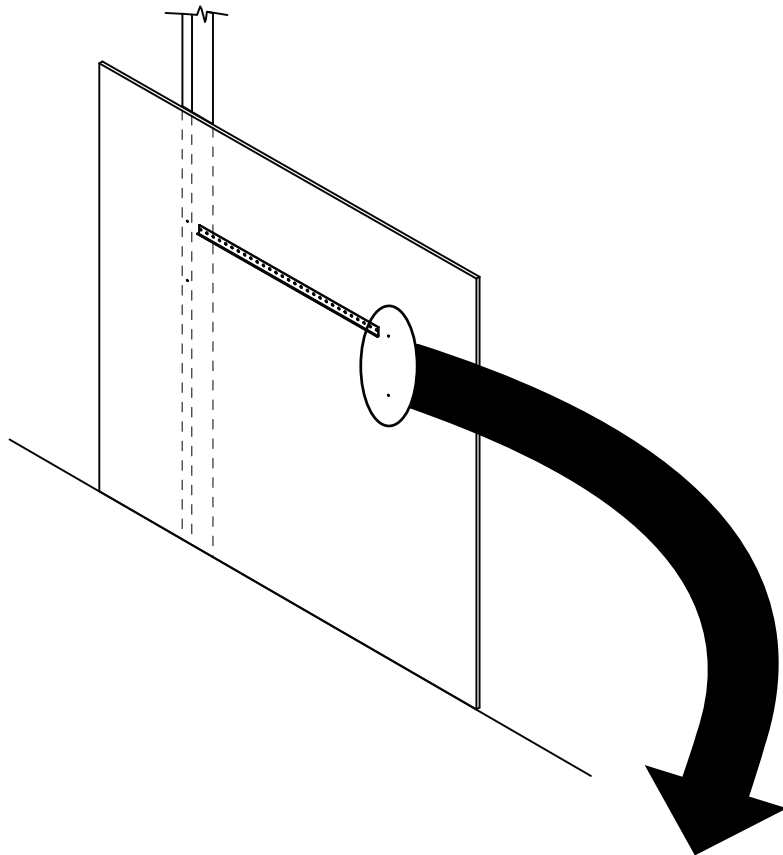

4

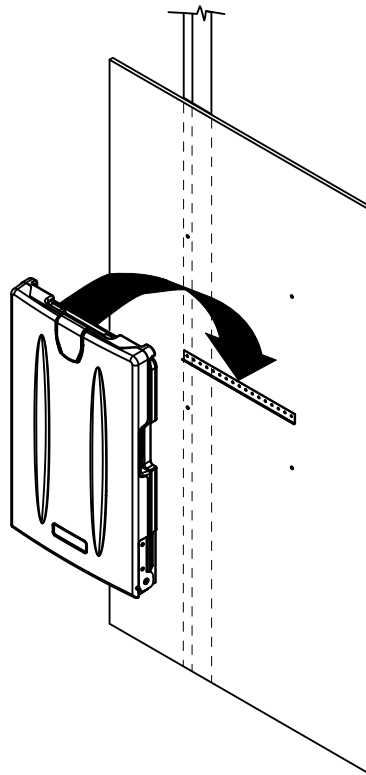

AB20558_G26

5

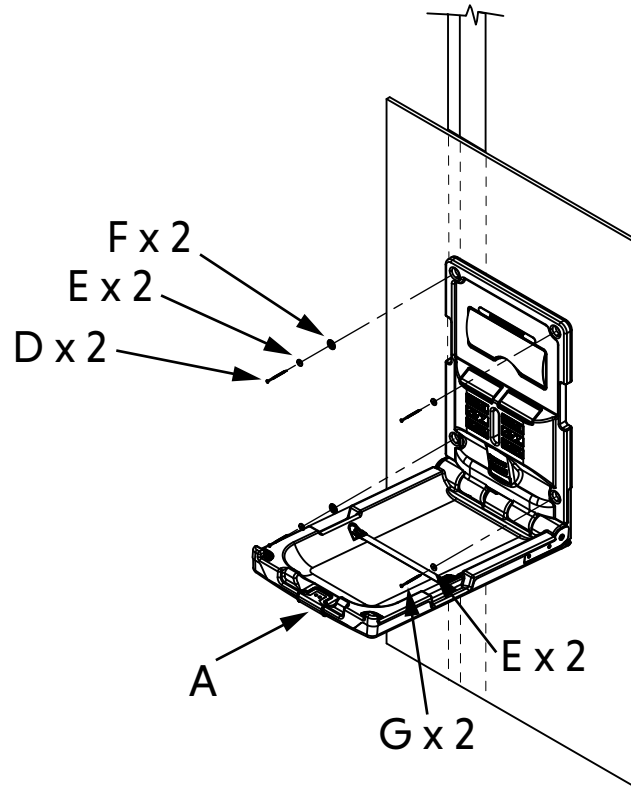

A x 1
D x 2
E x 4
F x 2
G x 2

IMPORTANTE: Asegúrese de que los cuatro (4) sujetadores estén bien apretados.

AB20558_G11

1 x 4

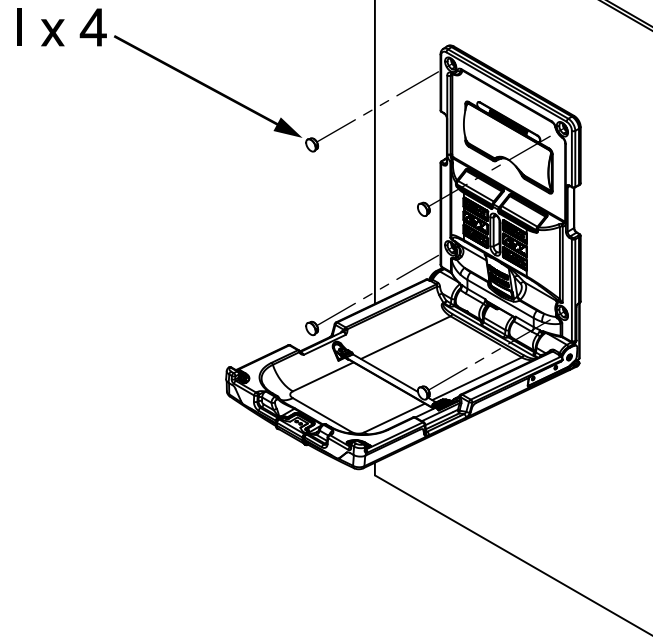

AB20558_G12

PLACARD DE PARED

C x 1

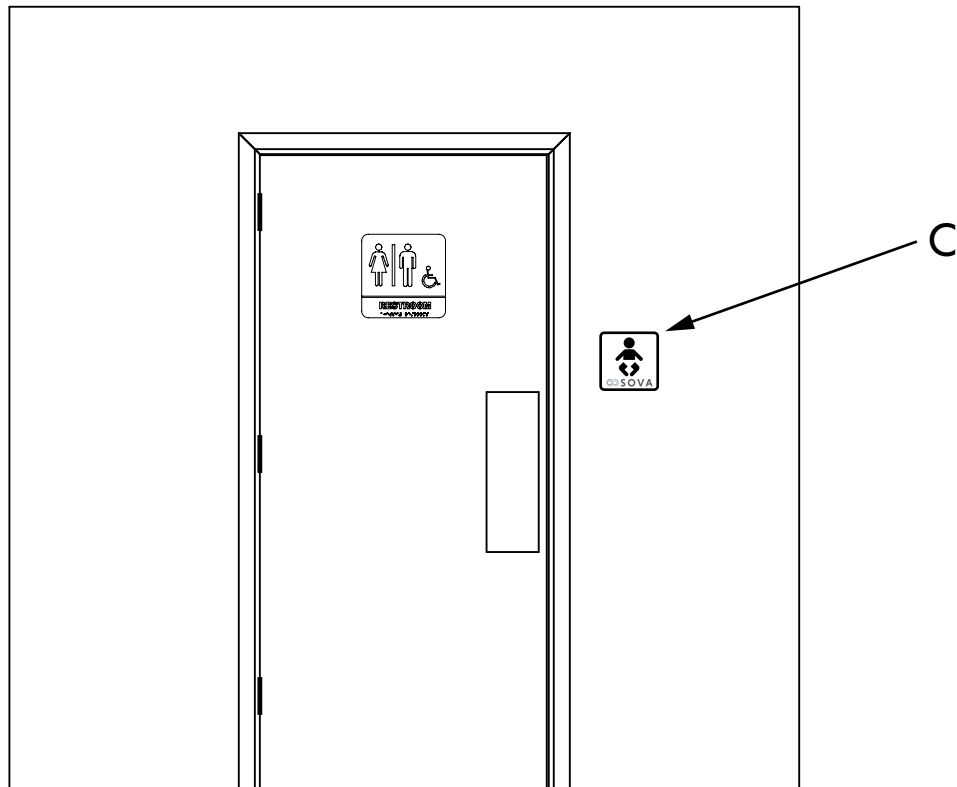

AB20572_G11

Montage vertical d'origine avec plaque de support EZ Mount™

10VS0201

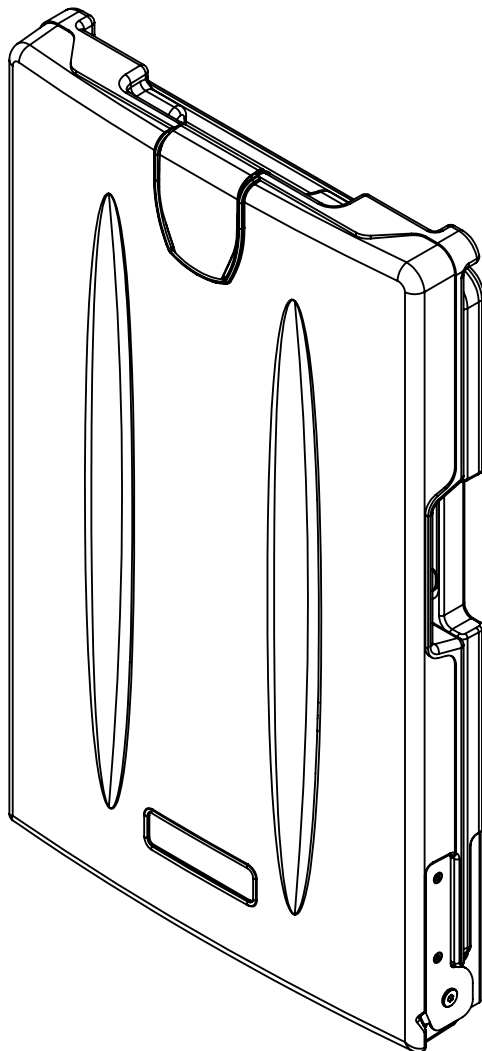

IMPORTANT. CONSERVER PARA FUTURAS CONSULTAS. LEA ATENTAMENTE.

⚠ AVERTISSEMENT

- Le non-respect de ces avertissements et des instructions d'installation pourrait entraîner des blessures graves ou la mort.
- Lisez toutes les instructions avant d'installer le station de change pour bébé. Conservez ces instructions. NE PAS jeter.
- Tous les quatre (4) emplacements de montage DOIVENT être utilisés pour une installation sûre. Les trous inférieurs offrent une installation renforcée grâce au support en métal.
- La station de changement de couches n'est pas plus solide que les ancrages ou les murs auxquels elle est attachée et, par conséquent, DOIT être fermement fixée afin de supporter le poids qu'elle est censée supporter. Contactez un architecte ou un entrepreneur en bâtiment si vous avez des questions.
- Un enfant ne devrait jamais être laissé sans surveillance.
- Évitez les blessures graves en tombant ou en glissant. Utilisez toujours un système de retenue.
- Ajouter un poids excessif, comme des colis, des paquets ou des accessoires, au dispositif ou aux crochets du sac qui dépasse la limite de poids totale de 50 livres (22,7 kg) peut rendre l'appareil instable ou créer une condition dangereuse et instable.
- Un minimum de 1 taquet doit être utilisé lors du montage de la station à langer. Si 1 taquet ne peut pas être utilisé d'un côté ou de l'autre, un matériel de blocage supplémentaire est requis.
- En plus de la plaque de support, montez la station de changement en utilisant les (4) vis de montage fournies. La plaque de support seule NE constitue PAS une méthode de fixation sécurisée.

OPÉRATION

- Faites pivoter la base vers le bas. Placez l'enfant sur la table à langer. Utilisez le système de retenue comme décrit ci-dessous. Une fois l'enfant changé, retirez le système de retenue et faites pivoter la base contre le mur.

UTILISATION DU SYSTÈME DE RETRAITE

- Placez l'enfant de manière à ce que la sangle de retenue soit au niveau de l'abdomen. Tournez le haut de la boucle vers le haut et insérez la sangle dans la boucle. Tirez la sangle à travers la boucle jusqu'à ce qu'elle soit bien ajustée contre l'enfant. Tournez le haut de la boucle vers le bas pour verrouiller la sangle. Glissez la languette de verrouillage rouge sur le dessus de la boucle (Fig. a). Procédez dans l'ordre inverse pour desserrer la sangle.

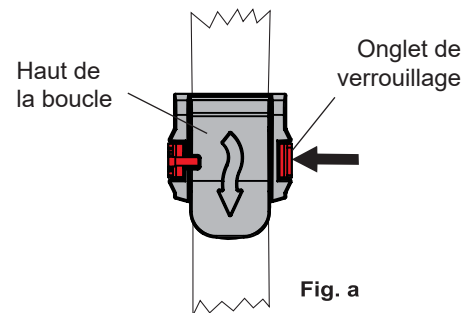

ENTRETIEN ET NETTOYAGE

- Vérifiez tous les matériels et composants chaque mois ou selon les besoins pour vous assurer que le matériel est bien serré et qu'il n'y a pas de composants manquants ou endommagés. Retirez l'unité du service si un composant est manquant ou endommagé et contactez le service client pour commander des pièces de rechange. Ne remplacez pas les pièces. Pour les pièces de rechange, contactez le service client au +1-234-400-0707.
- Nettoyez à l'aide d'un chiffon humide avec du savon doux ou un nettoyant multi-usages doux. N'utilisez pas de nettoyants chimiques forts ou de produits de nettoyage qui pourraient être dangereux pour les enfants.

Conformité A.D.A :

306.3 Dégagement du genou
307.2 Objets dépassant maximum
308.2 Portée Avancée
308.3 Atteinte latérale
309.4 Opération
902.3 Surface de travail



5216 Portside Dr.
Medina Ohio 44256 USA
Téléphone: +1 234.400.0707
www.ChooseSova.com

IMPORTÉ PAR :
The Sova Company™
30 Casebridge Court
Scarborough, ON M1B 3M5 CAN
+1 234.400.0707

Conforme lorsqu'il est correctement installé

OUTILS REQUIS

IMPORTANT : La construction en acier ou en blocs nécessite des équipements supplémentaires. Veuillez contacter un entrepreneur ou un architecte professionnel pour obtenir de l'aide afin de déterminer le matériel adéquat.

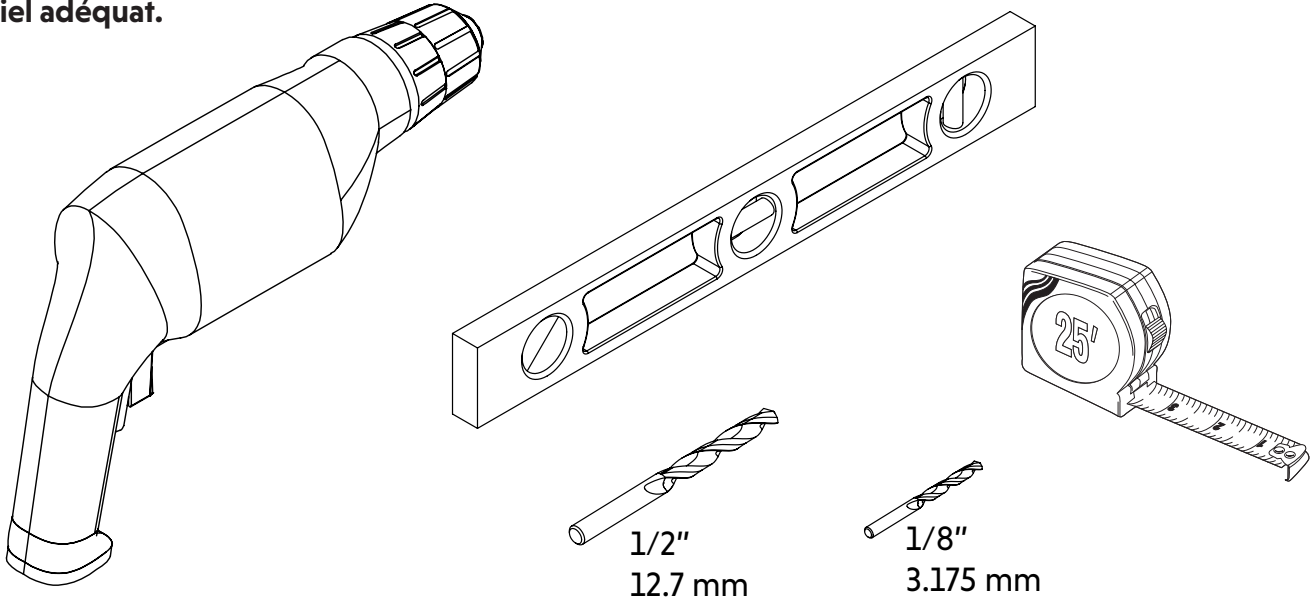

AB20556_G37

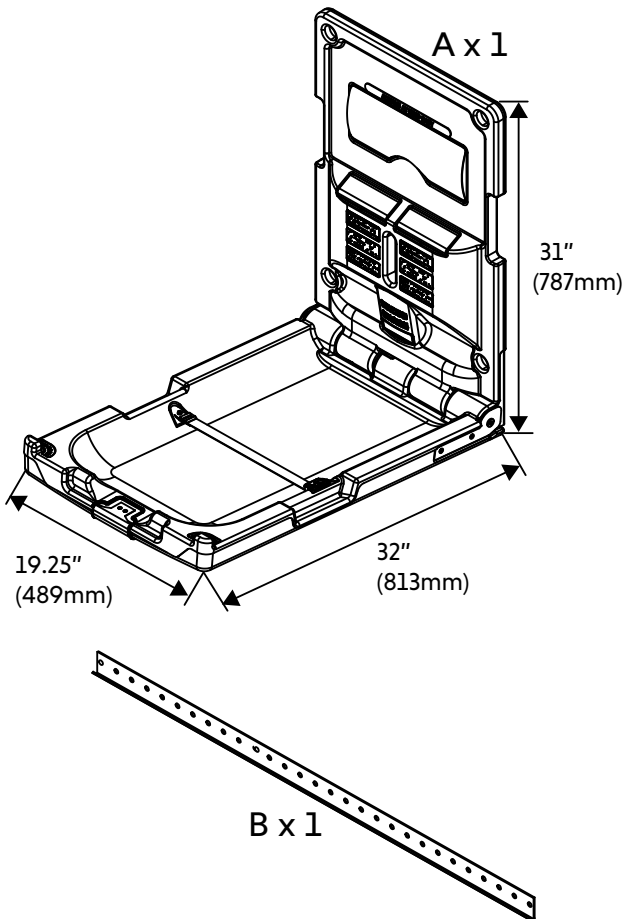

C x 1

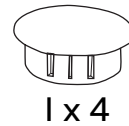

Pour les montants en bois:

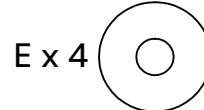
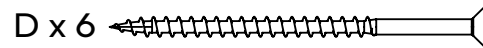

Pour les ancres de bascule:

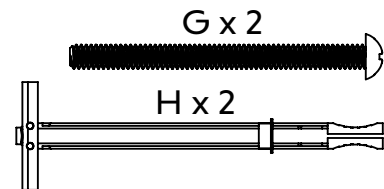

AB20558_G5

GUIDE DE PRÉINSTALLATION 1

La plaque de support est conçue pour améliorer la méthode de fixation en facilitant l'installation par une seule personne et offre une résistance supplémentaire par rapport à une installation sans unité.

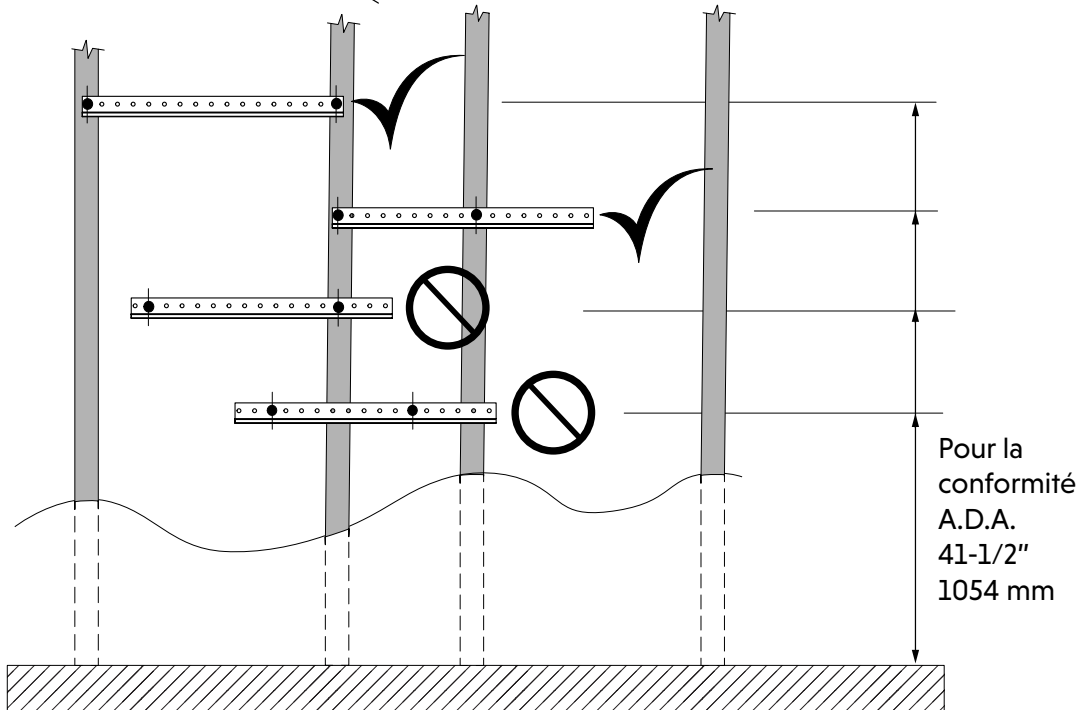
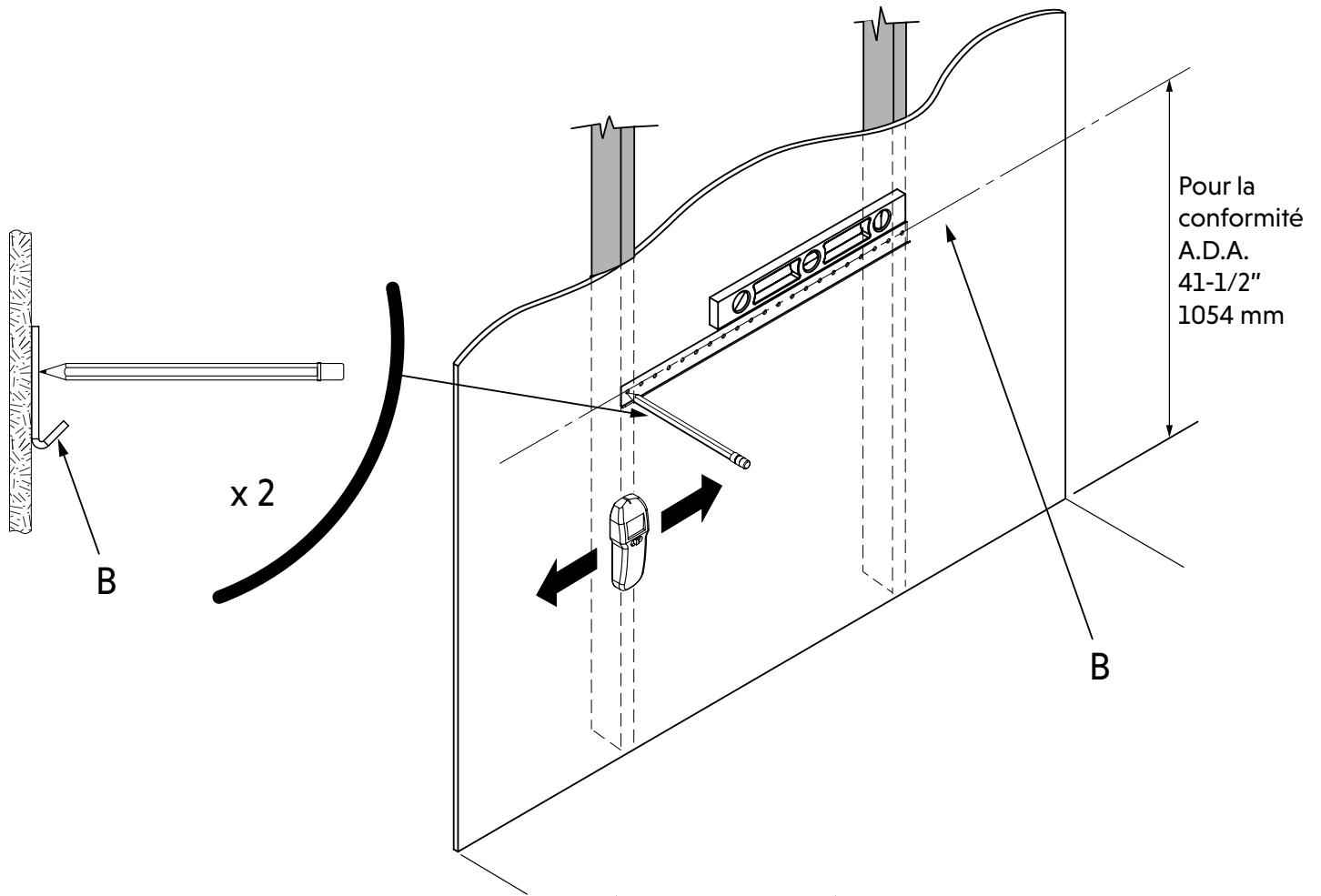

AB20558_G2

GUIDE DE PRÉINSTALLATION 2

B x 1

D x 2

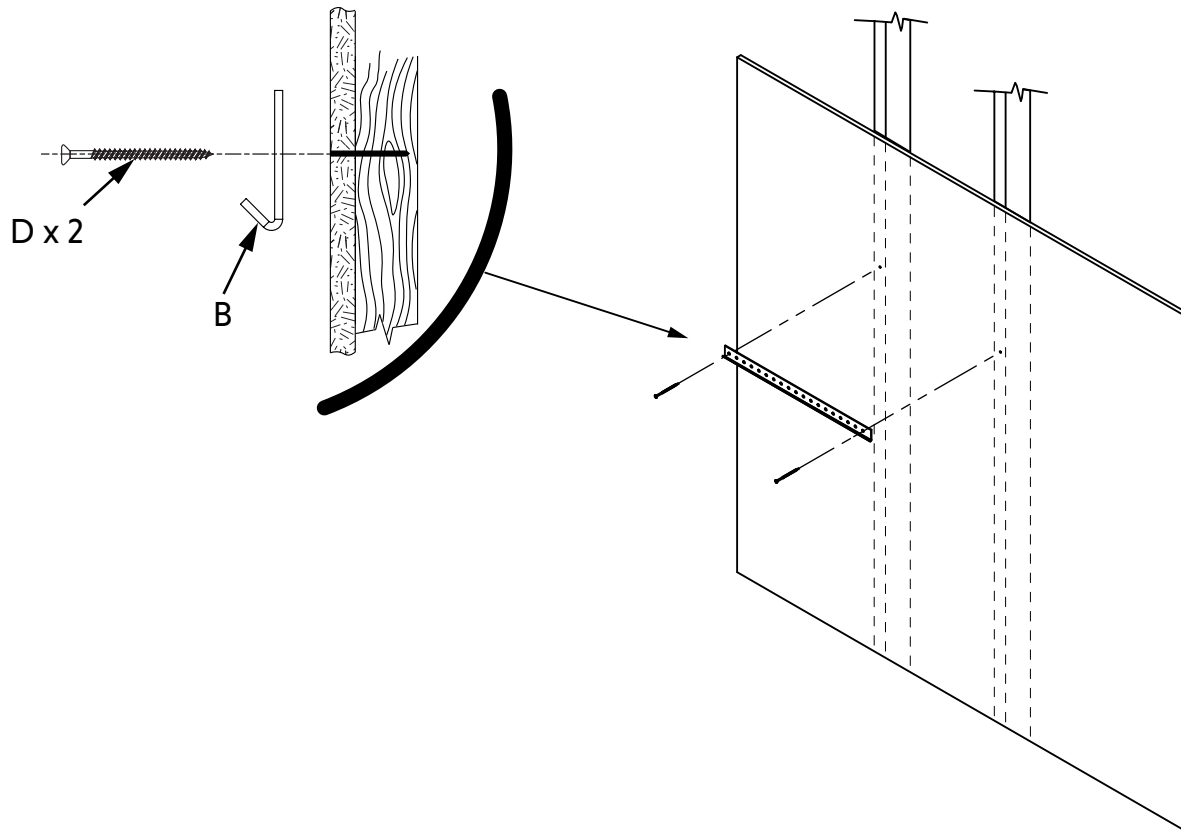

AB20559_G5

GUIDE DE PRÉINSTALLATION 3

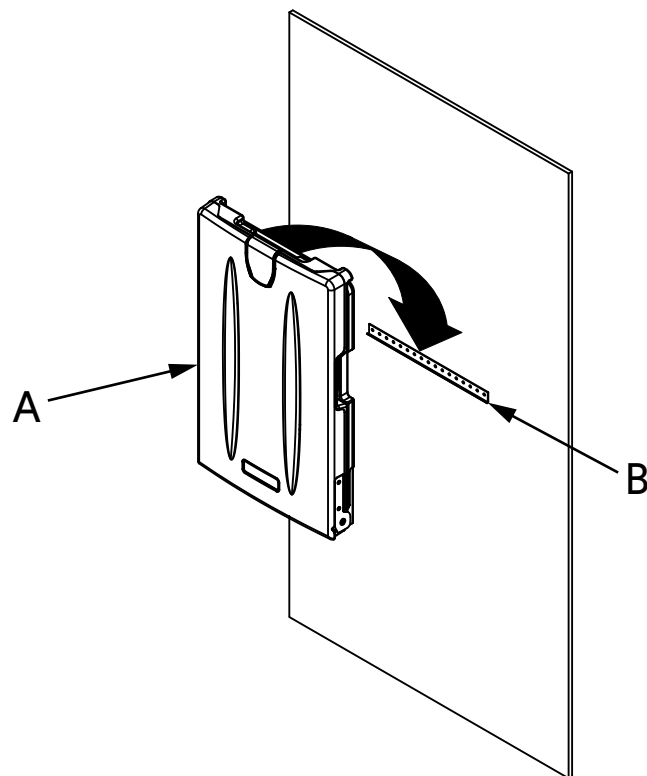

AB20558_G13

GUIDE DE PRÉINSTALLATION 4

IMPORTANT: Un minimum de 1 cheville doit être utilisé lors du montage de la table à langer. Si 1 cheville ne peut pas être utilisée de chaque côté, un matériel de blocage supplémentaire est requis. Veuillez contacter un architecte ou un entrepreneur professionnel pour vous assurer que le blocage est adéquat et conforme aux codes du bâtiment.

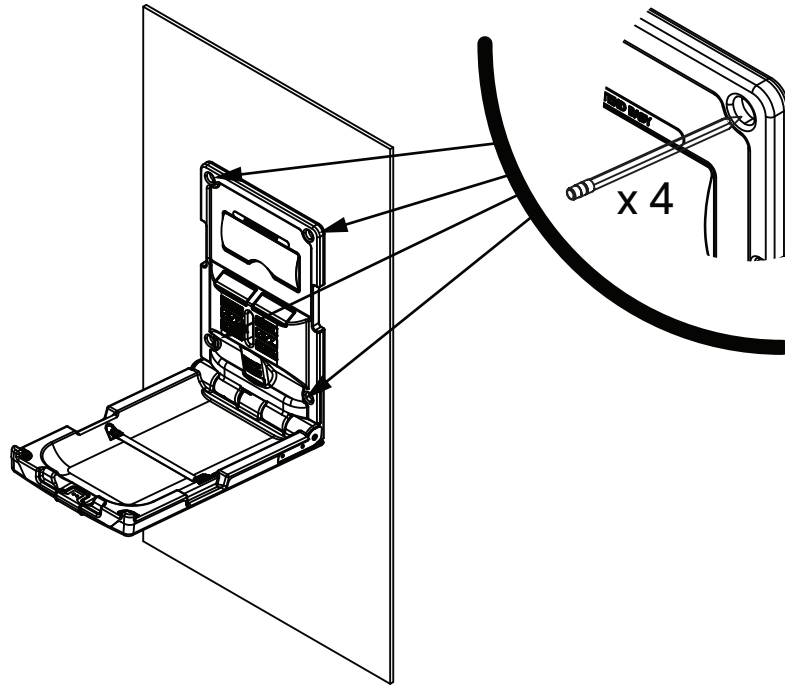

AB20558_G25

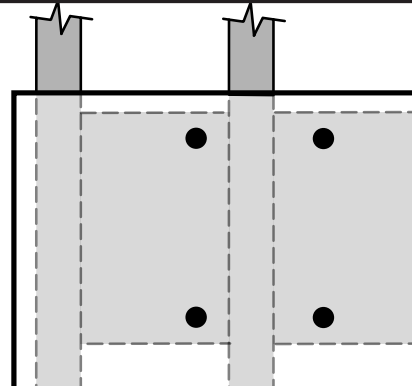
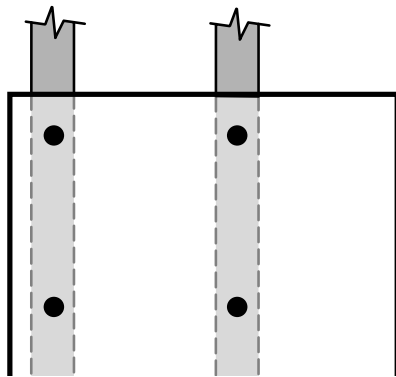

OPTION 1 - PAGE 37

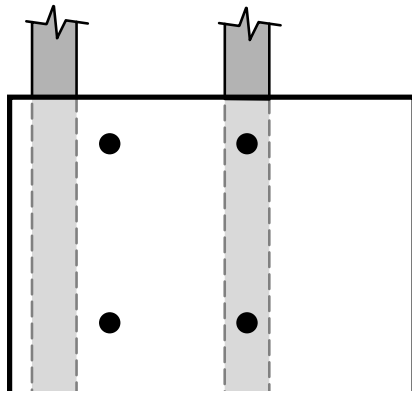

OPTION 2 - PAGE 41

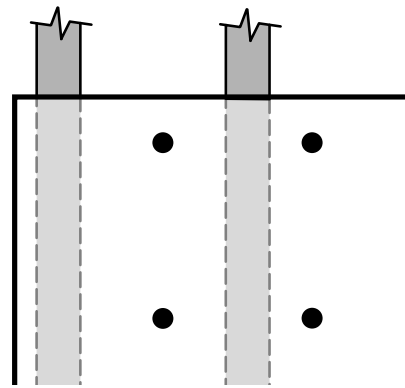

AB20559_G2

OPTION 1

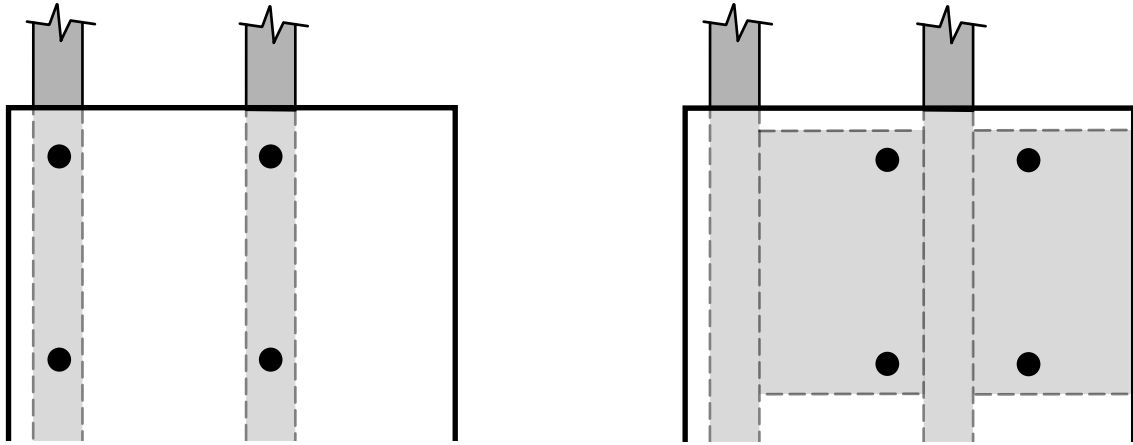

AB20559_G3

1

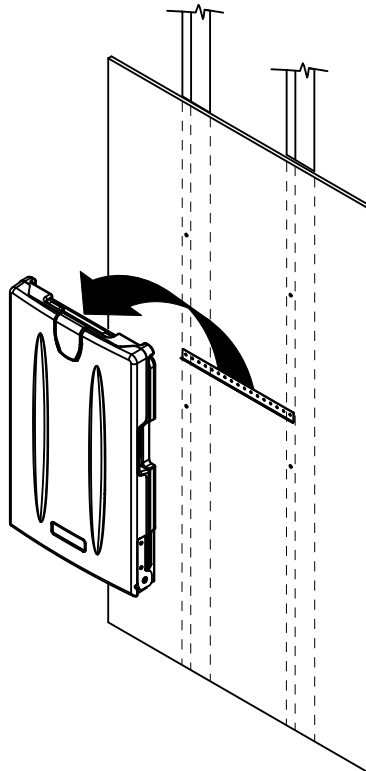

AB20558_G28

2

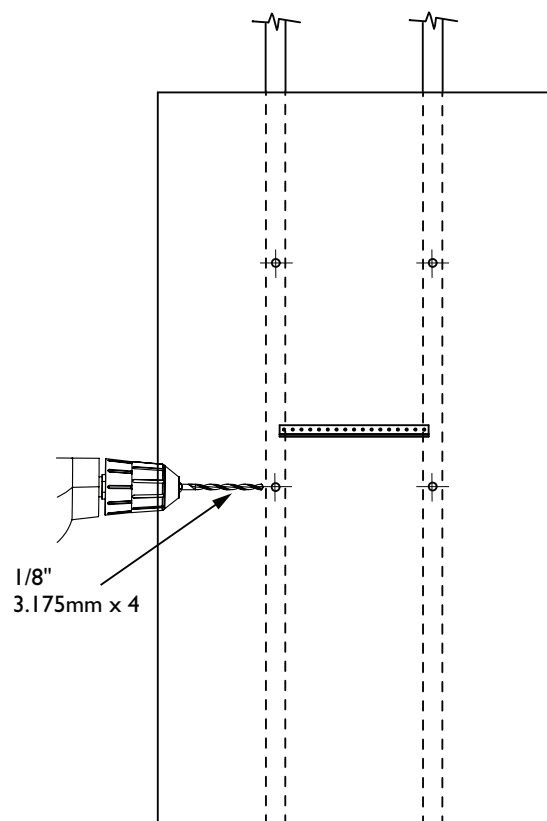

AB20558_G22

3

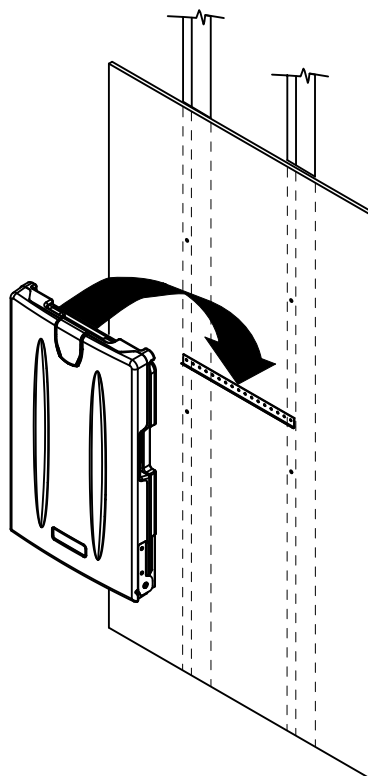

AB20558_G27

4

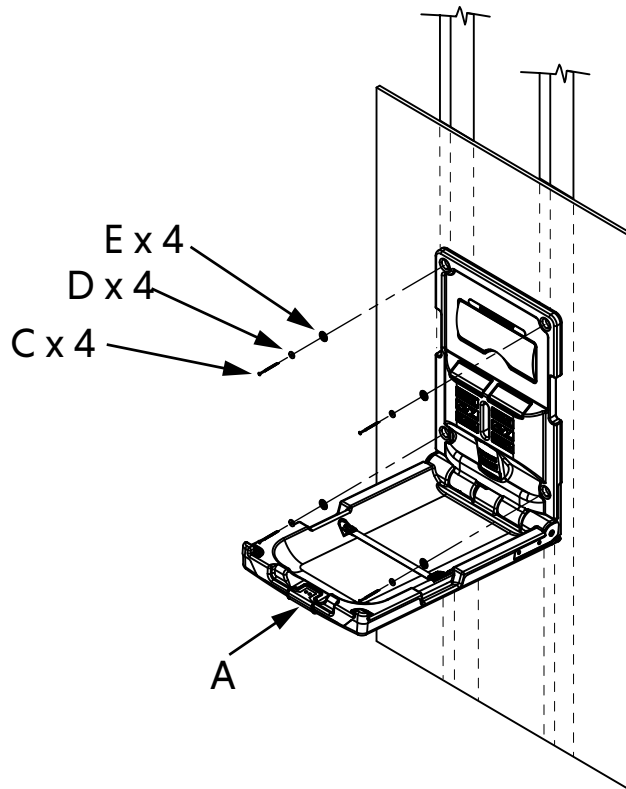

A x 1
C x 4
D x 4
E x 4

IMPORTANT : Assurez-vous que les quatre (4) fixations sont bien serrées.

AB20558_G10

5

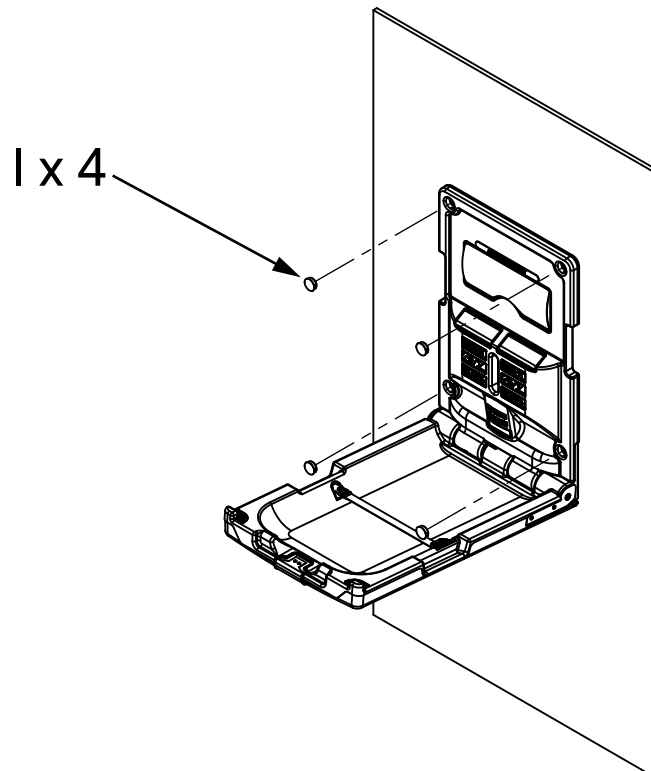

I x 4

AB20558_G12

PLACARD MURAL

C x 1

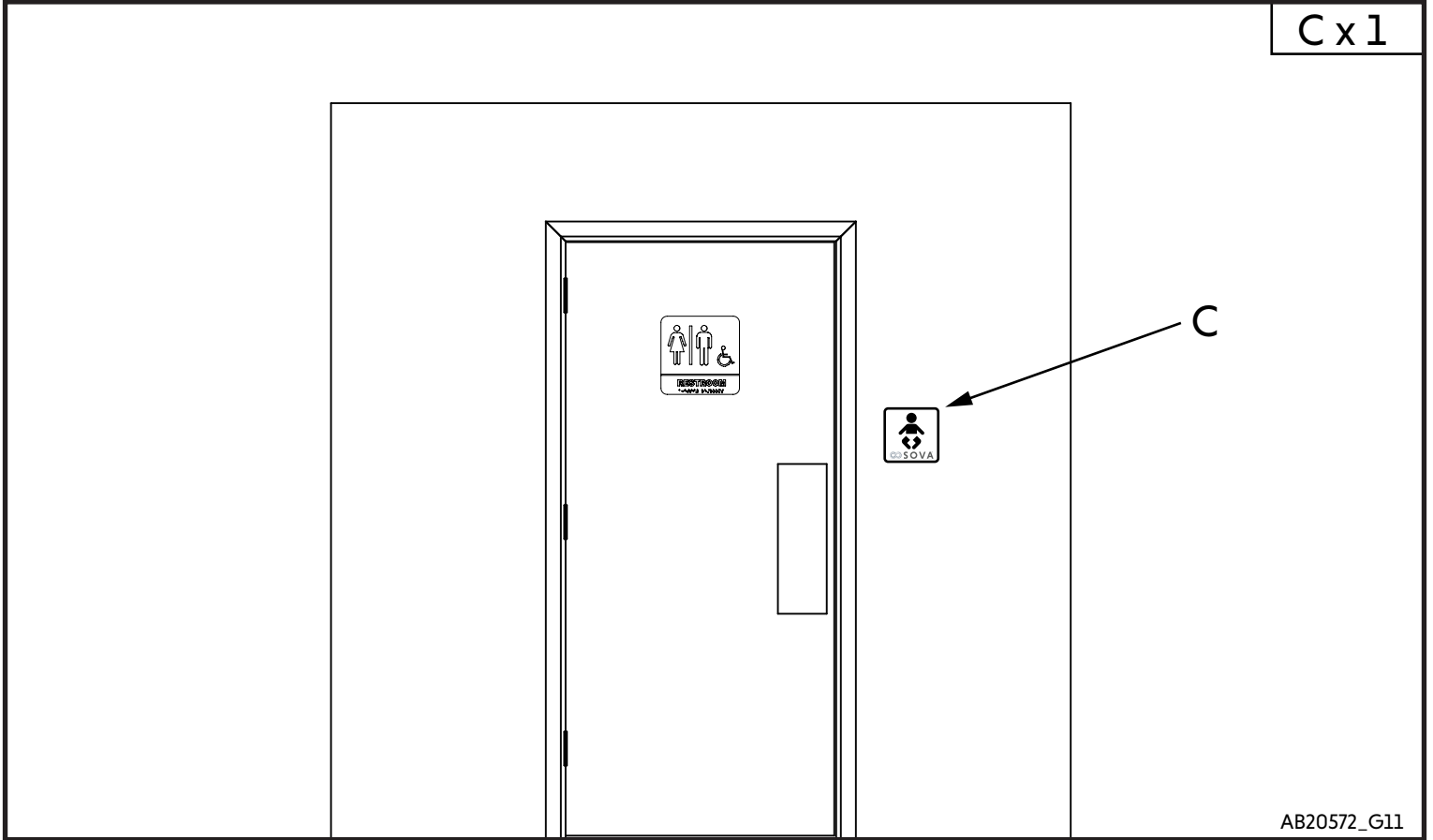

AB20572_G11

OPTION 2

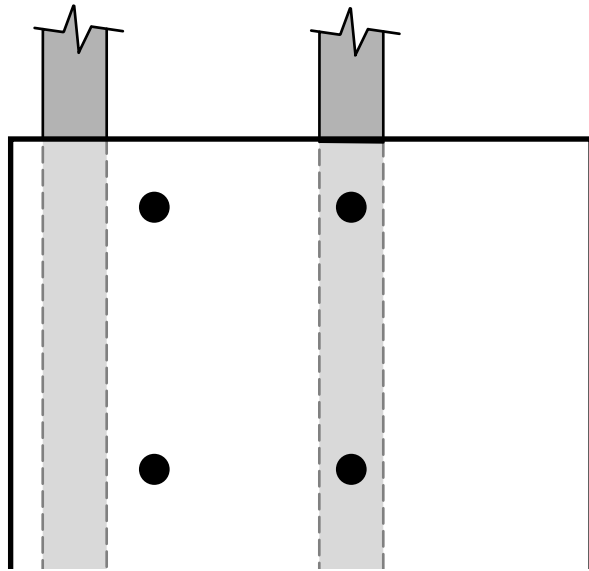

AB20559_G4

1

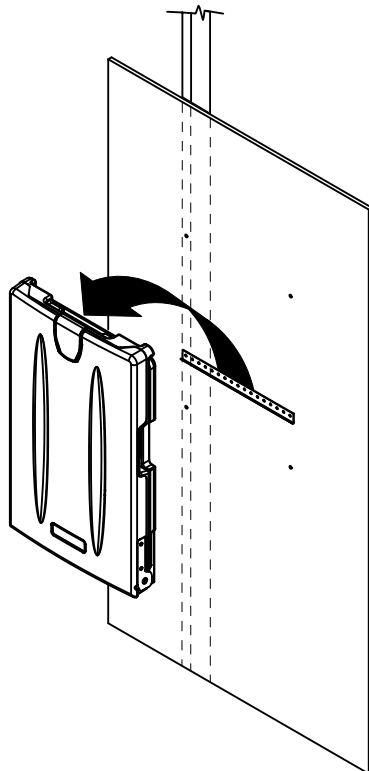

AB20558_G29

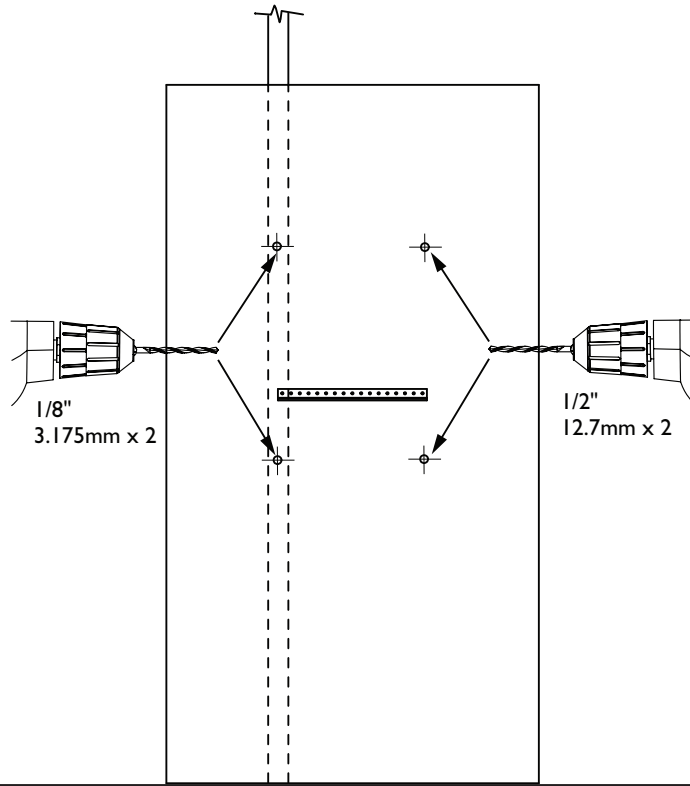

AB20558 G20

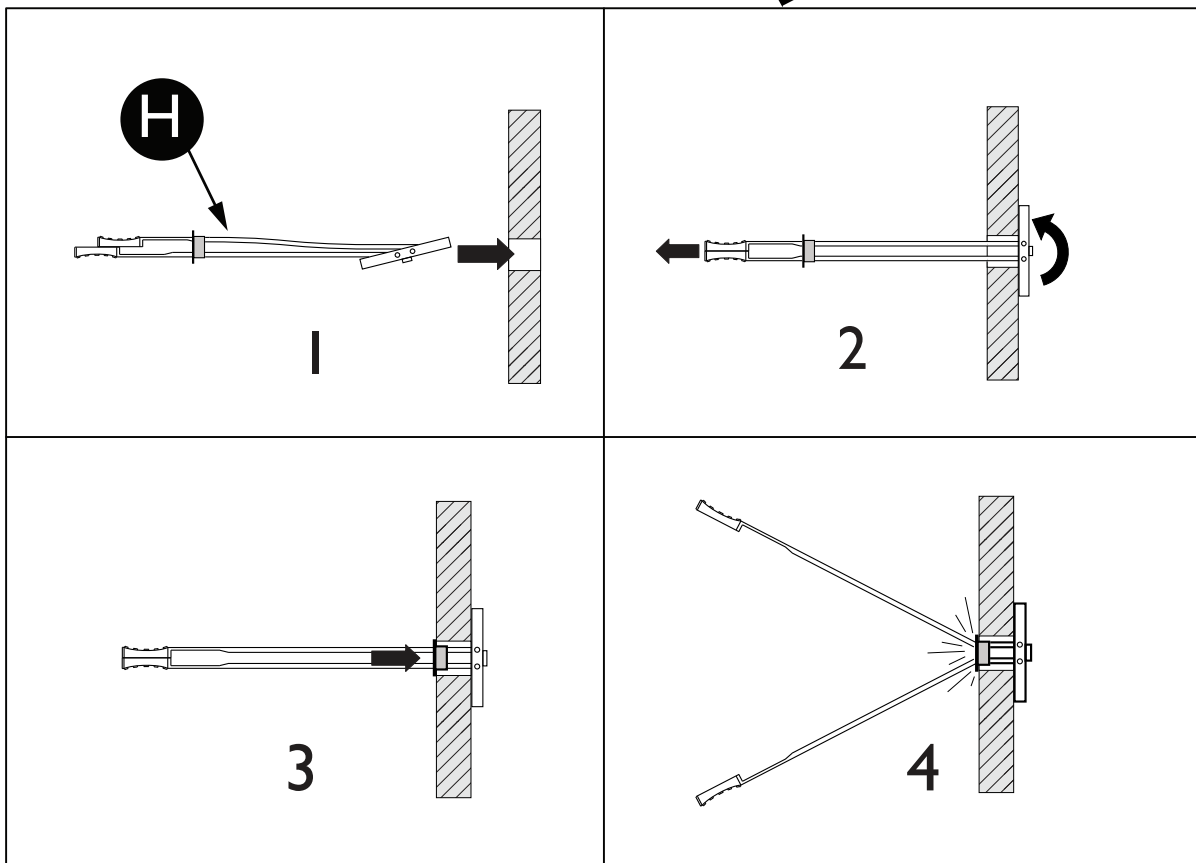
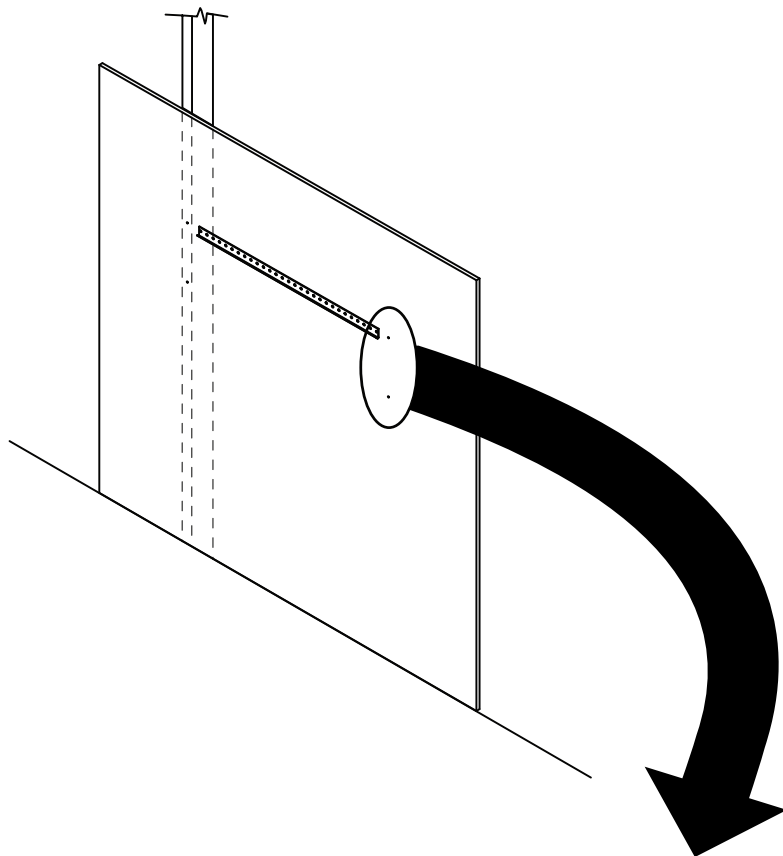

4

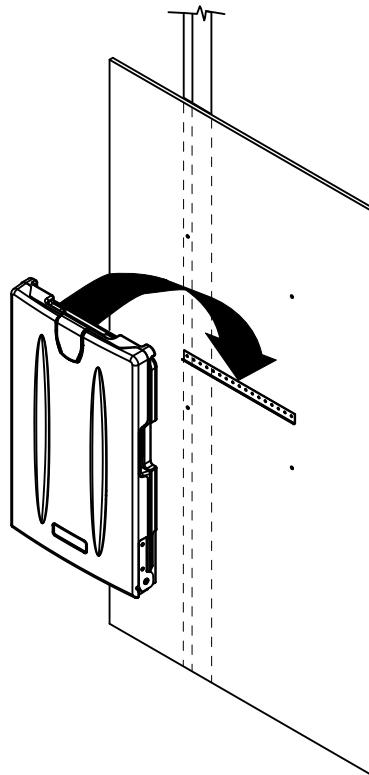

AB20558_G26

5

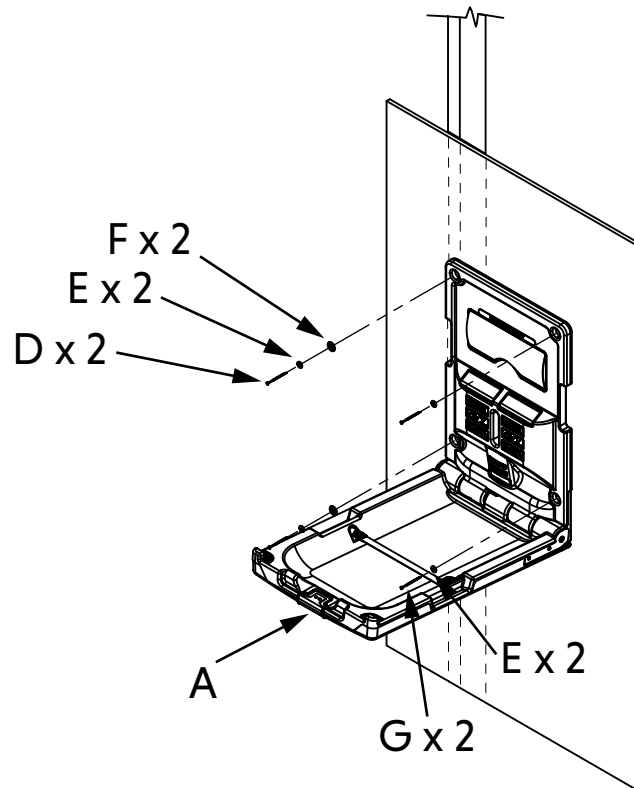

A x 1
D x 2
E x 4
F x 2
G x 2

IMPORTANT : Assurez-vous que les quatre (4) fixations sont bien serrées.

AB20558_G11

1 x 4

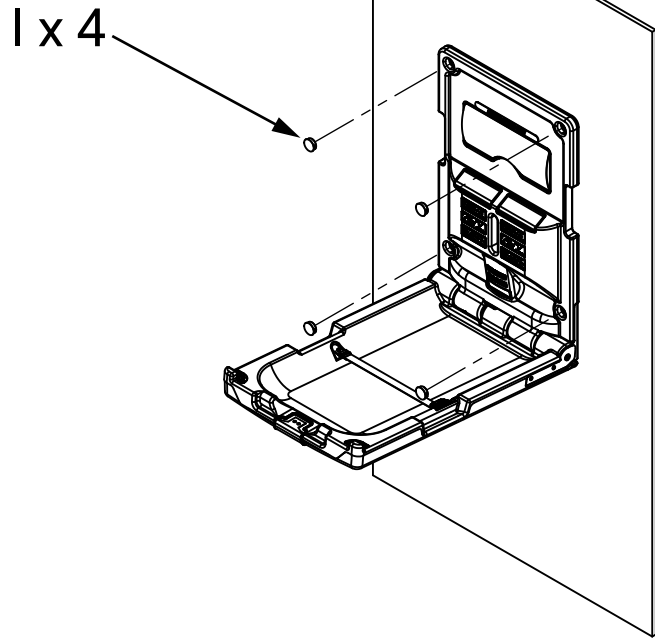

AB20558_G12

PLACARD MURAL

C x 1

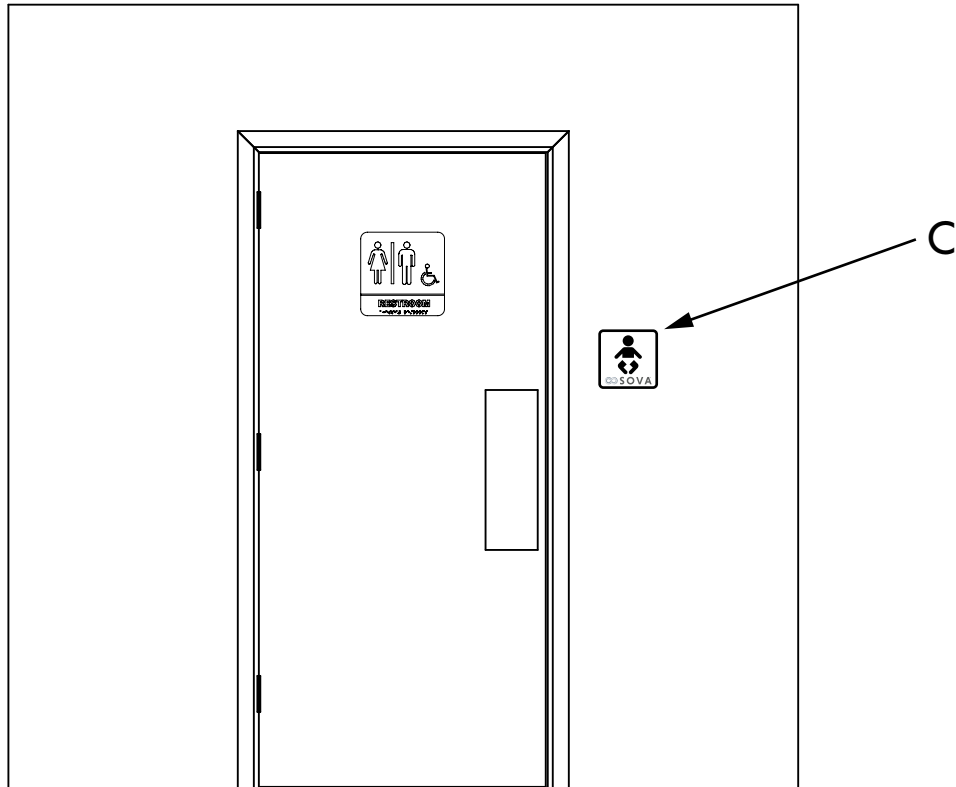

AB20572_G11