

ITEM NO.	MODEL NO.	DESCRIPTION	VOLTAGE	CURRENT	R290 CHARGE	CORD PLUG
RDCCB-48	RDC9348	CUBED COUNTERTOP 48"	120V	6.9A	135G/4.8OZ	5-15P

NOTES:

1. USER ADJUSTABLE DIGITAL TEMPERATURE CONTROLLER FOR TIME-TEMPERATURE CONTROLLED PACKAGED OR UNPACKAGED FOODS
 - TEMPERATURES BETWEEN 32°F (0°C) AND 46°F (8°C)
 - CABINET CAN ALSO BE USED AS AMBIENT DISPLAY
2. SELF-CONTAINED R290 REFRIGERATION SYSTEM WITH AUTOMATIC AND MANUAL DEFROST
3. GLASS HEATER TO KEEP CUSTOMER GLASS CLEAR
4. ZERO CLEARANCE ON ENDS, TOP AND OPERATOR SIDE MUST REMAIN OPEN FOR OPERATION AND SERVICE
5. UNIT SHOULD BE PLACED IN A FLAT, LEVEL POSITION. SEAL TO COUNTER OR PURCHASE OPTIONAL 4" ADJUSTABLE LEGS THROUGH VOLLRATH
6. TWO 3-POSITION ADJUSTABLE SHELVES WITH LED LIGHTING TO ILLUMINATE THE SHELF BELOW
7. LIFT AND REMOVE OPERATOR SIDE SLIDING DOORS
8. ARGON-FILLED AND SEALED DOUBLE PANE, LOW EMISSIVITY COATED GLASS
9. INTERNAL FANS TO CIRCULATE AIR AND PROVIDE EVEN TEMPERATURES
10. NSF DIAL THERMOMETER INCLUDED WITH EACH UNIT
11. 6-FOOT 120V, 15A POWER CORD
12. MATERIALS: STAINLESS STEEL, TEMPERED GLASS
13. UNIT WEIGHT: 352.8 LBS.
14. CERTIFICATIONS:
 - 1.) UL 471 10TH EDITION, FILE NUMBER: SA4847
 - 2.) UL SANITATION (TESTED TO NSF STD. 7), FILE NUMBER: SA45555
 - 3.) ENERGY PERFORMANCES STANDARD FOR COMMERCIAL REFRIGERATION EQUIPMENT CAN/CAS C657-2015

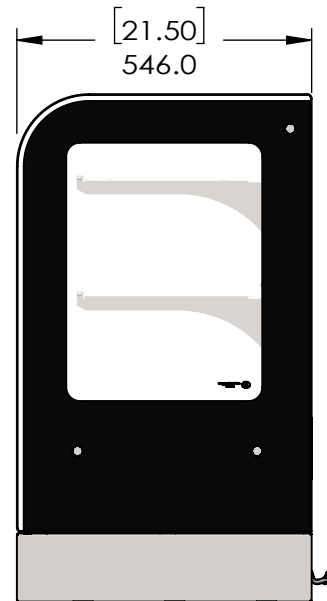
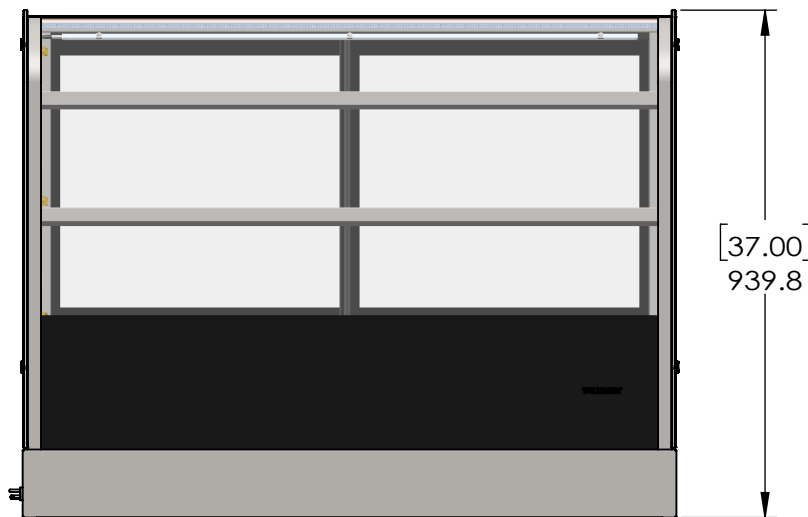
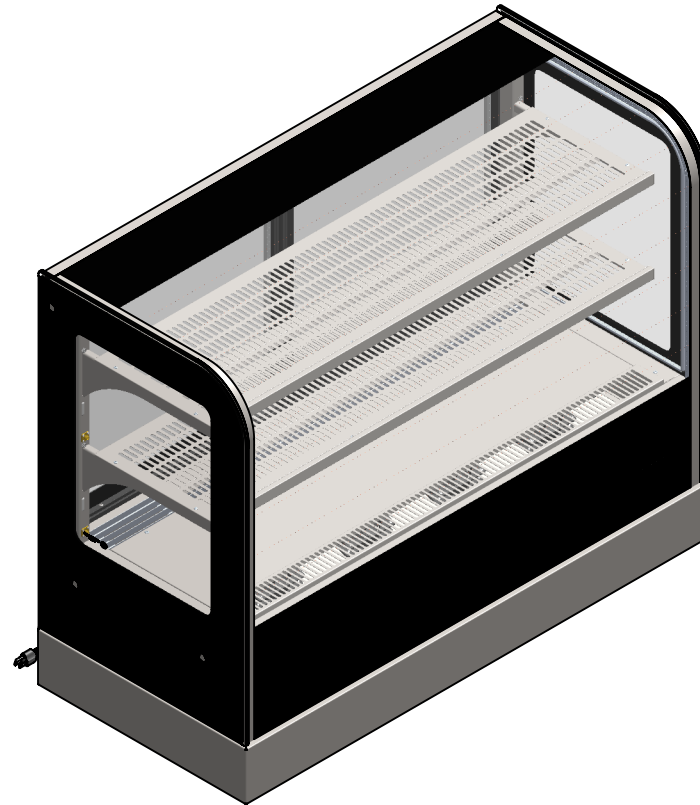
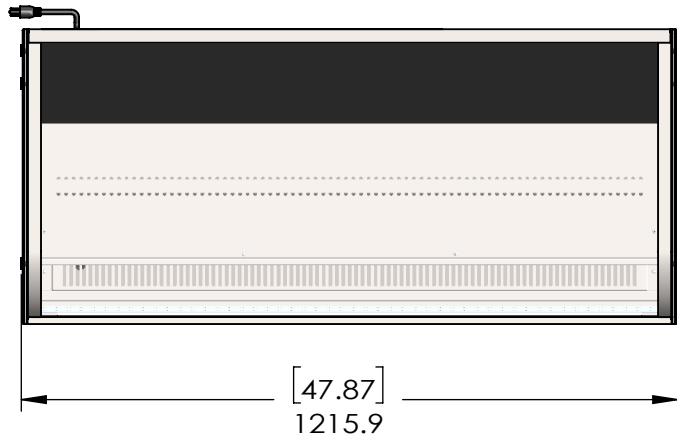

COMMERCIAL REFRIGERATOR
NSF/ANSI 7
SA45555



COMMERCIAL REFRIGERATOR
AND/OR FREEZER
719L



ENERGY PERFORMANCES STANDARD FOR
COMMERCIAL REFRIGERATION EQUIPMENT
CAN/CAS C657-2015

DIMENSIONS ARE IN MILLIMETERS (MM) UNLESS OTHERWISE NOTED.
DIMENSIONS IN BRACKETS ARE IN INCHES (IN) AND ARE FOR REFERENCE ONLY.

ITEM NO.	MODEL NO.	DESCRIPTION	VOLTAGE	CURRENT	R290 CHARGE	CORD PLUG
RDCCB-48	RDC9348	CUBED COUNTERTOP 48"	120V	6.9A	135G/4.8OZ	5-15P

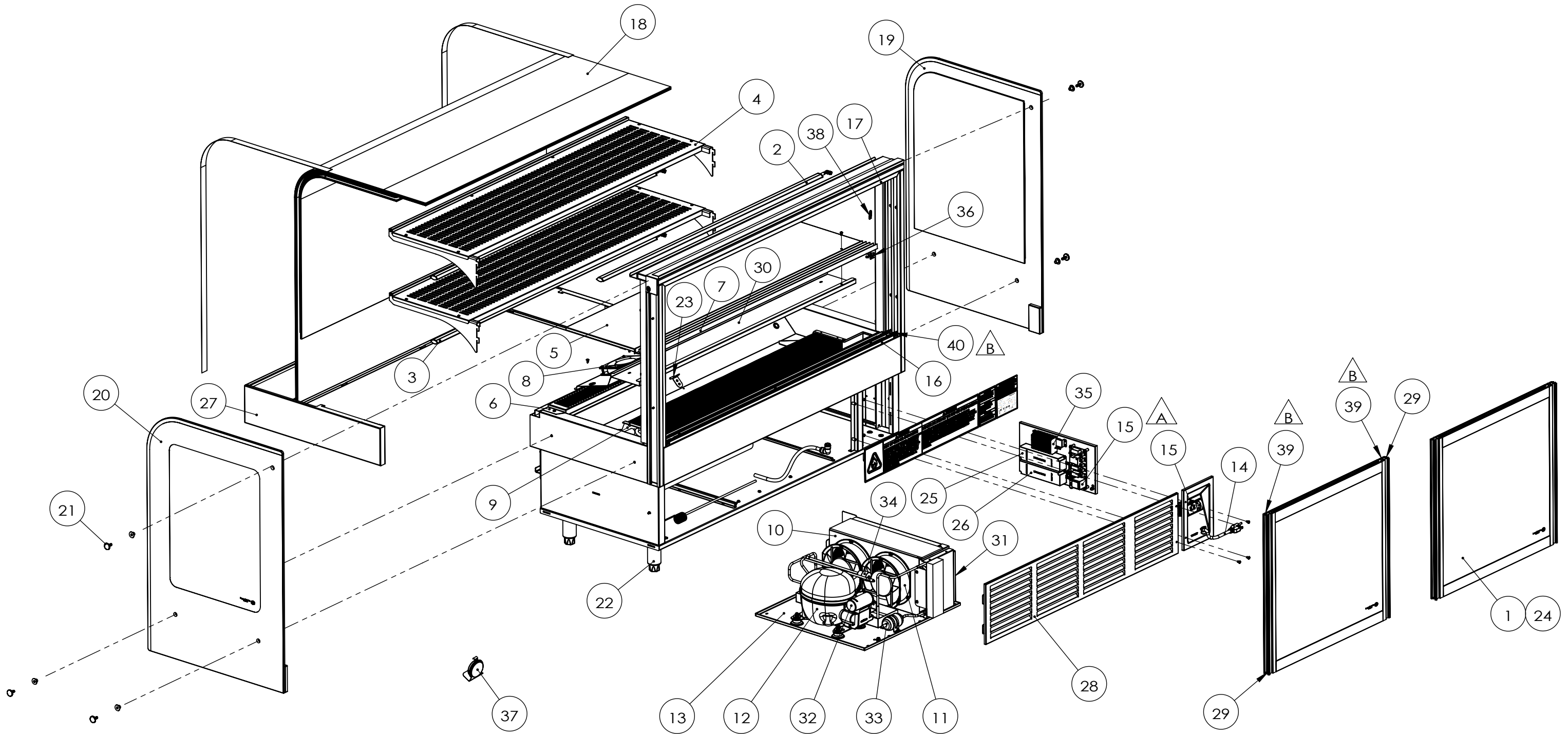

ITEM NO.	MODEL NO.	DESCRIPTION	VOLTAGE	CURRENT	R290 CHARGE	CORD PLUG
RDCCB-48	RDC9348	CUBED COUNTERTOP 48"	120V	6.9A	135G/4.8OZ	5-15P

SN	PART NO.	DESCRIPTION	QTY.
1	RDC0357-48	48" CUBED DOOR ASM	2
2	RDC0084-48S	48" LED 0.15M	1
3	RDC0084-48L	48" LED 0.50M	2
4	RDC0335-48	48" CUBED TOP SHELF ASM	2
5	RDC0356-48	48" CUBED BOTTOM SHELF	1
6	RDC0042-48	48" AIR OUTLET DUCT	1
7	RDC0088-48	48" REAR AIR GRILL	1
8	RDC0163	EVAPORATOR FAN	4
9	RDC0053-48	48" EVAPORATOR	1
10	RDC0149	RDE CONDENSER	1
11	RDC0258	CONDENSOR FAN	2
12	RDC0147L	EMC3140U COMPRESSOR	1
13	RDC0067-48&60B	48"&60" CUBED CONDENSING UNIT	1
14	RDC0501	POWERCORD W/STRAIN RELIEF	1
15	SEE TABLE	SEE TABLE	1
16	RDC0115-48	48" BOTTOM DOOR TRACK	1
17	RDC0128-48	48" BACK SLDNG DOOR TRACK UP	1
18	RDC0511	FRONT GLASS KIT, RDCCB-48	1
19	RDC0414	RDCCB END GLASS ASM-R	1
20	RDC0413	RDCCB END GLASS ASM-L	1
21	RDC0522	GLASS HARDWARE	6
22	2351601	4 INCH LEG ADJUSTABLE FOOT	4
23	RDC0141	RDE HDE NTC SENSOR	2
24	RDC0155	REAR DOOR SLIDER BTM WHEEL	4
25	RDC0145	POWER FOR LED	1
26	RDC0164	GLASS HEATING POWER	1
27	RDC0355-48	48" CUBED STAINLESS WRAP	1
28	RDC0127-48	48"BACK VENT PANEL REAR	1
29	RDC0362	CUBED DOOR GASKET	4
30	RDC0086-48	48" FAN PANEL ASM	1
31	RDC0039	RDE FILTER	1
32	RDC0112	CAPACITOR	1
33	RDC0106	RDE DRY FILTER	1
34	RDC0195	HIGH PRESSURE SWITCH	1
35	RDC0043	RDE TERMINAL BLOCK	1
36	RDC0066	3-PIN LED LIGHT SOCKET	3
37	RDC0273	COOL HOLDING THERMOMETER	1
38	RDC0523	SLOT PLUG, QTY. 4	2
39	RDC0704	DOOR INNER GASKET	4
40	RDC0705	END BLOCK	2

△ A

△ B

NOTE: FOR CONTROLLER, AS SHOWN IN THE TABLE BELOW.

SN	SERIAL NUMBER (YDDD)	CONTROLLER
15	CURRENT PRODUCTION, VERIFY CODE PZUXC9R1S1KT	RDC0700
	UP TO O252, VERIFY CODE PZUXCOE101	RDC0502