

VERTICAL HYDRAULIC SAUSAGE MILLERS

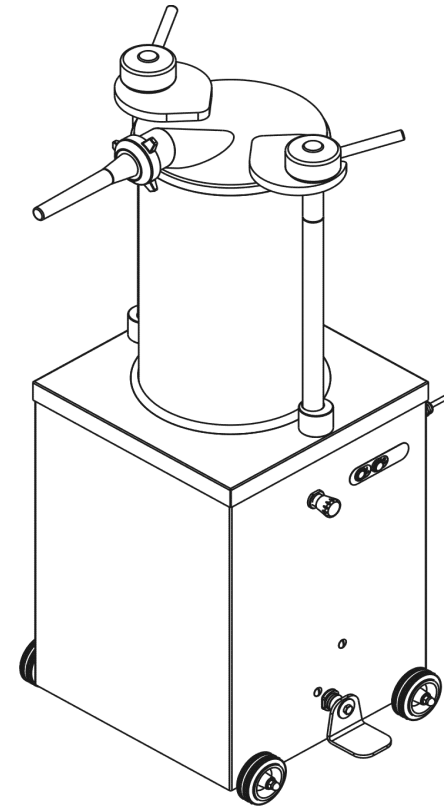

USE AND MAINTENANCE MANUAL

**ASSISTANCE CENTER
AUTHORIZED DEALER**

Ver. 7 12.2018

English

8 Problems and solutions

8.1 - Problems, causes and solutions

Problems	Causes	Solutions
The machine does not start	The plug is not correctly inserted in the outlet The electrical motor is broken down The command pedal microswitch is defective The pressure gauge is broken down	Carefully insert the plug in the outlet Contact technical assistance Contact technical assistance Contact technical assistance
The thrust of the plug is not linear	Air is present in the hydraulic circuit or there is a lack of oil	Contact technical assistance
Oil leak	The oleodynamic cylinder gaskets are worn The hydraulic circuit pipe is closed incorrectly or insufficiently	Contact technical assistance Contact technical assistance

7.5 - Remount the cylinder (not applicable for IS 15)

For correct remounting of the cylinder, follow this procedure:

- wet the stopper gasket and the internal edge of the cylinder with some water;
- position the cylinder in its housing, taking care not to pinch the gasket (fig. 7.5.1);
- insert spring "1" into its housing (fig. 7.5.1.);
- insert cover "2" onto the rods until it is resting on the cylinder (fig. 7.5.2.);

N. B: In the models IS35 and IS50, ask for assistance to remove the cover considering its high weight.

- screw the safety rings of cover "3" onto the rods until the cover is firmly locked on the cylinder (fig. 7.5.3.);

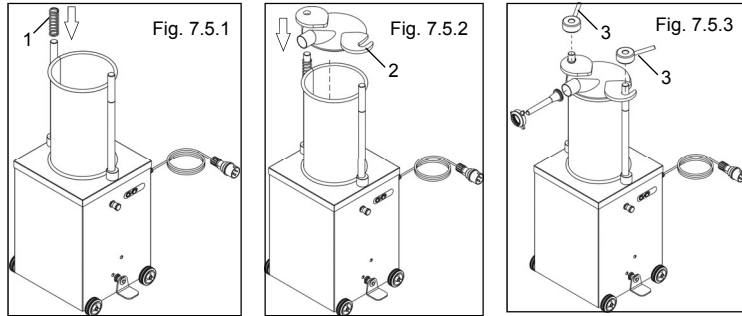

7.4 WEEE Waste of Electric and Electronic Equipment

Directive 2002/95/EC, 2002/96/EC and 2003/108/EC on the restriction of the use of certain hazardous substances in electrical and electronic equipment, and waste electrical and electronic equipment



This symbol, crossed out wheelie bin, on the product or on its packaging indicates that this product must not be disposed of with your other household waste.

Separate waste collection of this appliance is organised and managed by the manufacturer. It is the user's responsibility to contact the manufacturer and follow the waste treatment system the manufacturer has adopted for separate waste collection.

The separate collection and recycling of your waste equipment at the time of disposal will help to conserve natural resources and ensure that it is recycled in a manner that protects human health and the environment.

Index

1. Delivery and warranty	5
1.1 Introduction	
1.2 How to keep and use the manual	
1.3 Warranty	
1.4 Description of the machine	
1.5 Foreseen use	
1.6 Unforeseen uses	
1.6.1 Safety prescriptions	
1.6.2 Environmental conditions	
1.6.3 Lighting	
1.7 Registration data	
1.7.1 Environmental conditions	
1.8 Safety protections and devices	
1.9 Work stations	
1.10 Vibrations	
2. Technical features	10
2.1 Main parts	
2.2 Technical features	
2.3 Dimensions and weight of the machine	
2.4 Electrical diagrams	
2.4.1 Single phase electrical diagram	
2.4.2 Three phase electrical diagram	
2.5 Hydraulic diagrams	
3. Testing, transport, delivery and installation	14
3.1 Testing	
3.2 Delivery and moving the machine	
3.3 Installation	
3.3.1 Disposing of the packages	
3.3.2 Moving the machine	
3.4 Connecting the electrical system	
3.4.1 Three-phase machine	
3.4.1 Single-phase machine	
4. Controls	16
4.1 List of controls	
5. Start up and stop	17
5.1 Checking the electrical connection	
5.2 Checking the presence and efficiency of protection devices	
5.3 Checking the running of the command pedal	
5.4 Start up	
5.5 Stop	

6. Machine use	18
6.1 Prescriptions	
6.2 Machine use	
7. Maintenance	19
7.1 Prescriptions	
7.1.1 Periodical controls	
7.2 Lubrication	
7.3 Cleaning the machine	
7.4 Dismantling the cylinder (not applicable for IS 15)	
7.5 Remount the cylinder (not applicable for IS 15)	
7.6 WEEE Waste of Electric and Electronic Equipment	
8. Problems and solutions	23
8.1 Problems, causes and solutions	

7.4 - Dismantling the cylinder (not applicable for IS 15)

For correct dismantling of the cylinder, follow this procedure:

- unscrew and remove the safety ring of cover "1" (fig. 7.3.1.);
- remove cover "2" by lifting it in a vertical direction (fig. 7.3.2.);

N. B.: In the models IS35 and IS50, ask for assistance to remove the cover considering its high weight.

- remove spring "3" (fig. 7.3.3.);
- connect power cable "4" to the power line (fig. 7.3.3.);
- turn the differential switch upstream of the machine to position 1;
- press the machine's start button "5" (fig. 7.3.4);
- press the pedalboard until the cylinder is lifted by approx. 50 mm (fig. 7.3.5.);
- turn ejectors "8" so that they support the cylinder (fig. 7.3.6.);
- using the tip of your foot, lift the pedalboard so that the stopper is lowered and returns to its initial position (fig. 7.3.6.).

N.B.: During this operation, guide the cylinder with your hands until the stopper is completely extracted

- lift the cylinder and remove it from the machine

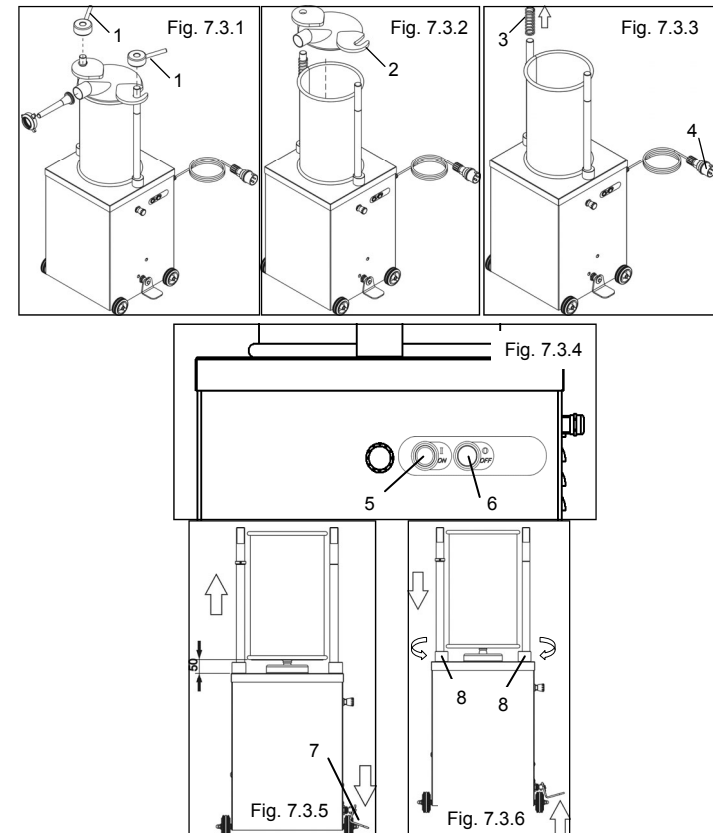

ATTENTION!

When replacing worn or damaged parts always use original spare parts to not vary technical features. If original parts are not used the safe running of the sack filling machine could be compromised

7.1.1 - Periodical controls

Check the hydraulic oil level in the tank every six months.

If oil is lacking the plug does not reach the limit on top and therefore top off the oil which must have the same characteristics as the one indicated in the table below.

Manufacturer	Initials
AGIP	OSO 46
ESSO	NUTO H 46
FINA	HYDRAN 46

Note

The correct level of the hydraulic oil must be done with the plug completely closed in a resting position.

7.2 - Lubrication

The machine does not need to be lubricated.

7.3 - Cleaning the machine

ATTENTION!

Disconnect the machine from the power network before cleaning it.

Do not clean the machine with a jet of water.

In particular: do not use a water cleaner.

Only use non toxic detergents, expressly destined for cleaning parts for food use.

To adequately clean the machine of mixture residue remove the cover by unfastening the locking ring nuts "4" fig. 6.2.1.

N. B: In the models IS35 and IS50, ask for assistance to remove the cover considering its high weight.

Extract the cylinder by lifting it perpendicularly to the two pins "10" and "11" fig. 6.2.1.

Clean the cylinder, plug and the external parts of the machine with water and non toxic detergent then dry all the parts.

Reassemble everything and close it with the cover "5" with the lever "4" on the cylinder "7" (fig. 6.2.1).

If the plug "8" must be disassembled (fig. 6.2.1) act in the following way:

- Bring the plug to the lower limit by lifting the pedal (to block it from turning);
- Unfasten the plug without the help of wrenches and proceed to accurately cleaning it.
- Reassemble the disassembled parts by carrying out the disassembly steps in reverse.

1 Delivery and warranty

1.1 - Introduction

ATTENTION!

The symbols used in this manual are meant to call the attention of the reader to dangerous points and operations for the personal safety of the operators or that could cause risks of damaging the machine.

Do not operate the machine if you are not sure of having completely understood the information highlighted in these notes.

ATTENTION!

Some illustrations contained in this manual show the machine or parts of it without the panels or carters to make the figures clearer.

Do not use the machine in such conditions, only use it if every protection is correctly assembled and working.

The manufacturer forbids reproduction, even partial, of this manual and its contents cannot be used for other purposes.

Any violation will be persecuted according to law.

1.2 - How to keep and use this manual

The purpose of this manual is to explain the essential criteria and prescriptions concerning transport, movement, use and maintenance of the machine to the users through texts and figures.

Therefore carefully read this manual before using the machine.

Take care of it and keep it near the machine, in a place that can be quickly and easily reached for any future consultation.

If the manual is lost or ruined, ask your reseller or the manufacturer for another copy.

If the machine is given away, inform the manufacturer of the address and phone number of the new owner.

The manual reflects current trade techniques for the machine and cannot be considered inadequate if after new experiences it has been updated.

In fact the manufacturer reserves the right to update production and relative manuals without having to update previous production and manuals, except for exceptional cases.

In case of doubt consult the nearest assistance center or directly contact the manufacturer.

The manufacturer is interested in continuously improving its products.

For this reason the manufacturer is happy to receive any comments or suggestions that could help improve the machine and/or manual.

The machine has been delivered to the user in the warranty conditions valid at the moment of purchase.

Contact your supplier for any clarifications.

1.3 - Warranty

The user must not mishandle the machine for any reason. Contact the manufacturer for any anomaly found. If the machine is disassembled, modified or any part of it is mishandled by the user or unauthorized personnel the Compliance Declaration written according to the CEE 2006/42 Directive will be forfeited, the warranty will be invalid and the manufacturer will be relieved of any responsibility for damages to both people or things caused by such mishandling.

Furthermore, the manufacturer is not responsible in the following cases:

- incorrect installation;
- improper use of the machine by inadequately trained personnel;
- use contrary to laws in force in the country;
- lack of or incorrect maintenance;
- use of unoriginal spare parts or parts not specific for the model;
- total or partial inobservance of the instructions.

1.4 - Description of the machine

The sack filling machine in your possession is a simple, compact and highly productive machine.

The structure is made of AISI 304 steel.

The cylinder is in polished AISI 304 stainless steel, with rounded edges, without a mandatory assembly sense.

The plug is made of AISI 304 stainless steel for food products.

It is perfectly sealed thanks to a NBR gasket on the cover and another one on the plug.

The cover is made of AISI 304 stainless steel and it is equipped with a slot so it can open and close quickly without having to use tools.

The mechanical pedal and the maximum pressure valve in the hydraulic circuit make the machine comply with safety laws.

Furthermore it is outfitted with:

- plug advancement adjustable by means of a tap;
- three different sizes of polyethylene funnels, that can be easily interchanged ;
- plug return always at maximum speed;
- wheels so it can be easily moved.

The models represented in this manual have been built in compliance with the CEE 2006/42 Directive and successive modifications.

In the case of an accident the manufacturer cannot be held responsible if the machine has been modified, mishandled, used in ways unforeseen by the manufacturer or if safety protections have been removed.

- After having connected the machine to the electrical line press the start push button "1" fig. 6.2.1 .
- Lift the pedal and wait for the plug to reach the limit.
- Loosen the ring nuts "4" that block the cover by a few turns. Lift the cover and turn it sideways as in fig. 6.2.1.
- Fill the cylinder "7" with mixture so that the plug "8" is in a low position.
- Replace the cover in its proper seating and block it with the corresponding ring nuts. Check that the sealing gasket has not come out of its proper seating.
- After having chosen and assembled the exit funnel by means of the ring nut "9", fig. 6.2.1 push the start push button "1".
- Press the pedal and the plug will start the work run by pushing the mixture towards the exit funnel. The speed is determined by the tap "2". Turning it clockwise lowers the plug pushing speed while turning it counterclockwise increases the speed.
- When the content of the cylinder is finished bring the plug into its initial position by lifting the pedal (fig. 6.2.1).

N. B: To preserve its freshness and properties, it is recommended to work the meat at a maximum temperature of 7°C and terminate the process within 10 minutes. Once the meat has been processed, clean all the parts carefully (see par. 7.3-7.4-7.5).

7 Maintenance

7.1 - Prescriptions

ATTENTION! *Every maintenance and cleaning intervention on the sack filling machine must be carried out only when the machine is stopped and disconnected from the electrical power supply.*

The area where maintenance is done must always be kept clean and dry.

Do not allow unauthorized personnel to intervene on the machine.

Any replacement of parts must be done with original spare parts at authorized workshops or directly by the manufacturer.

Make sure that all the parts of the hydraulic circuit have been closed properly.

Before disassembling pipe fittings or piping make sure there is no fluid under pressure: the oil that comes out under pressure could cause serious damage.

If there is damage or fluids that come out of the piping, etc. are accidentally swallowed, immediately contact a doctor.

In particular remember that: the fluid that comes out of a very small hole can be almost invisible and have enough force to penetrate the skin. Use a card or piece of wood to look for leaks.

Never use your hands !!!

If the fluid comes into contact with the skin immediately contact a doctor. In fact serious infections or skin problems could develop if prompt medical treatment is not sought.

5.3 - Checking the running of the command pedal

When the machine is connected to the supply mains and after having pressed the start push button (fig. 5.1.1) press the pedal and check the movement of the plug in the cylinder. Bring the pedal into the correct central position and make sure that the piston stops.

Note When pressing the pedal, with the start push button deactivated, the plug should not move.

5.4 - Start up

- Put the differential switch located at the head of the machine in "I".
- Press the start push button "3" (fig. 5.1.1).
- Press the pedal "4".

5.5 - Stop

- Press the stop push button "3".
- Put the differential switch in "0".

6 Machine use

6.1 - Prescriptions

ATTENTION!

Only authorized personnel can intervene on the machine.

Before starting to use the machine the operator must make sure that all the protections are in place and that the safety devices are present and efficient. If that is not the case turn off the machine and contact the person in charge of maintenance. Carry out some unloaded maneuvers assisted by specialized personnel to acquire the experience needed to work in safety.

6.2 - Machine use

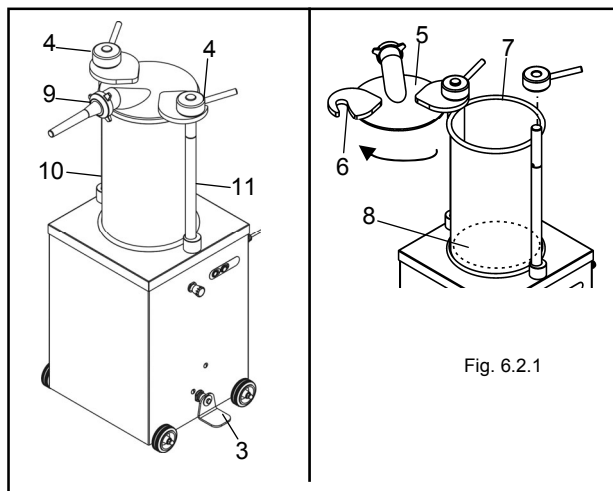

Fig. 6.2.1

1.5 - Foreseen use

The machine has been designed and built to fill sacks with meat mixtures or similar products.

It must be used in professional environments and personnel who use it must operate in the sector and must have read and understood this manual. The machine must be used when it is placed on a flat and clean surface.

1.6 - Unforeseen uses

The machine must be used only for the purposes foreseen by the manufacturer. In particular:

- do not use the machine if it has not been correctly installed with all of the protections in one piece and correctly assembled to avoid the risk of serious personal injuries.
- do not access electrical components without having previously disconnected the machine from the electrical supply mains: there is the risk of electrocution.

1.6.1 - Safety prescriptions

- Do not carry out any intervention without previous authorization.
- Respect the procedures given for maintenance and technical assistance.
- Do not wear clothes that do not comply with safety laws. Consult the employer about safety prescriptions in force and safety devices to be used.
- Do not start up a broken down machine. Before using the machine make sure that any situation that could compromise safety has been eliminated. If there is any irregularity stop the machine and notify persons in charge of maintenance.
- Do not allow unauthorized personnel to intervene on the machine. If an accident is caused by the electrical current the machine operator must be immediately taken off the machine (because one usually loses consciousness). This operation is dangerous. The injured person in this case is the operator: touching him means being electrocuted. It is therefore opportune to disconnect the contacts directly from the line feeding valve; if that is not possible move the victim away by using insulated materials (wooden or pvc sticks, fabric, leather, etc...). Medical personnel must promptly intervene and the patient must be recovered in a hospital.

1.6.2 - Environmental conditions

The machine is foreseen to run in the following environmental conditions:

- altitudes that do not exceed 1000 m
- minimum environmental temperature: -5 °C
- maximum environmental temperature: +40 °C
- relative humidity: 50%

1.6.3 - Lighting

The place where the machine is installed must have adequate natural and artificial lighting that complies with the laws in force in the country the sack filling machine is installed in.

In any case the lighting must be uniform and guarantee good visibility in every point of the machine and it must not create dangerous reflections.

The lighting must enable a clear reading of the control panel and easily individuating the emergency push buttons.

1.7 - Registration data

An exact description of the "Model", the "Serial number" and the "Construction year" of the machine will facilitate quick and efficacious responses on behalf of our technical assistance service. It is advisable to indicate the machine model and the serial number every time you contact the assistance service.

Observe the data on the plate shown in fig. 1.7.1.

As a reminder we suggest writing the data from your machine in the following square.

Sack filling machine model
Serial N°
Year of construction.....
Tipo.....

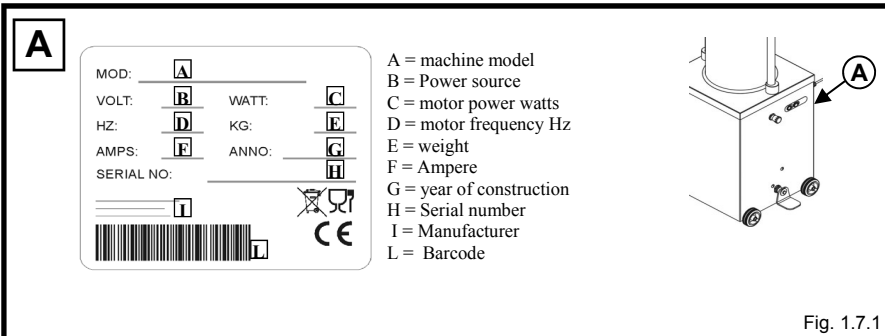

Fig. 1.7.1

ATTENTION!

Never alterate the data shown on the plate for any reason.

1.7.1 - Warning and danger plates (fig. 1.7.2)

ATTENTION!

When the machine is connected to the electrical supply do not intervene on electrical components. You risk being electrocuted.

Respect the warnings on the plates. Not observing them could cause personal injuries.

Make sure the plates are always present and legible.

If they are not, put them on or replace them.

3 - Command pedal (fig. 4.1.2)

The pedal is mechanical.

The forward movement of the plug towards the exit funnel is determined by exerting pressure downwards after having pressed the start button.

On the contrary, pushing the pedal up blocks the it thus determining the return stroke of the plug.

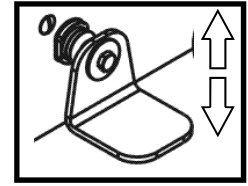

Fig. 4.1.3

5 Start up and stop

5.1 - Check that the lectrical connection is correct

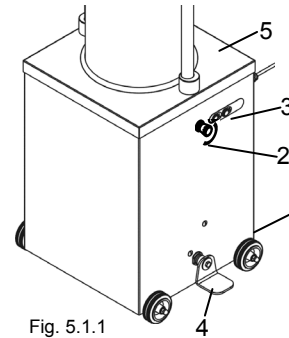

Fig. 5.1.1

ATTENTION! Check that the electrical feeding line corresponds with the value shown on the machine identification plate and that it has an efficacious grounding.

Assemble the 16 Ampere plug (not provided) on the feeding calbe "1" of the machine (fig. 5.1.1) and connect it to an outlet with a differential switch that has the proper capacity and is placed ahead of it. In the three-phase version the rotation direction of the motor must be checked by proceeding in the following way:

1. Remove the back carter "5" fig. 5.1.1.
2. Put the differential switch in the position "I", press the start push button "3" in fig. 5.1.1 then press the pedal; at the same time check that the motor turns in the direction indicated by the arrow located on the electrical motor.
3. If this is not the case immediately stop the machine by means of the differential switch or the stop push button. Invert two of the three phase wires in the plug and repeat the operation described above.
4. Once the correct motor rotation direction has been ascertained, reassemble the carter.

ATTENTION! If the motor turns in the opposite direction of the arrow located on the electrical motor it could cause serious damage to the hydraulic central station.

Note The correct rotation direction in machines connected to a single-phase line and made for such feed is directly defined by the manufacturer.

5.2 - Checking the presence and efficiency of protection devices

1. **Protection carter for internal parts**
Visibly check that it is positioned and fastened in the correctly.
2. **Cover blocking ring nuts**
Visibly check that they are closed in correctly before each work shift.

3.4.1 - Three-phase machine from 400 V-50 Hz and 230 V-50 Hz

With these set ups the machine is provided with a feeding cable with a 4x1 section and a length of about 1.5 meters. Connect the cable to the three-phase supply mains interplacing a 16 Ampere magnetothermic differential switch.

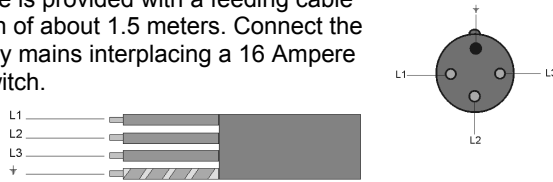

3.4.2 - Single-phase machine from 230 V-50 Hz

With this set up the machine is provided with a feeding cable with a 3x1.5 section and a length of about 1.5 meters. Connect the cable to the 230 Volt-50 Hz single-phase supply mains interplacing a 16 Ampere magnetothermic differential switch.

In set ups with voltages different from those mentioned consult the manufacturer.
If the feeding cable must be extended use a cable with the same section as the one installed by the manufacturer.

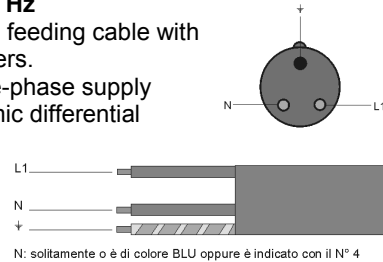

4 Controls

4.1 - List of controls

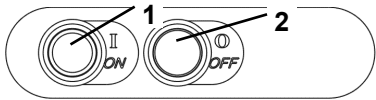

Fig. 4.1.1

1 - Stop/start up pushbutton panel

- It enables turning on and turning off the machine.
- Stop push button: it stops the plug from moving forward when it is moving. It is marked by a lit green indicator which indicates the presence of tension.
 - Start push button: it permits the plug to move forward; when it is selected it is marked by a lit orange indicator.

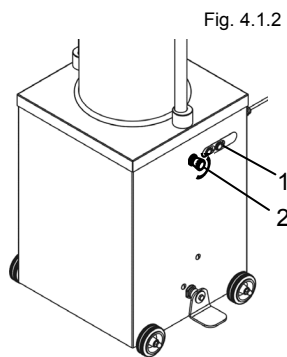

Fig. 4.1.2

Note: the forward movement of the plug is controlled by the mechanical command pedal. The start push button indicates only that the machine is ready to work.

2 - Speed adjustment tap

This tap acts on the valve located in the hydraulic circuit. Turning it clockwise lowers the plug pushing speed; turning it counter-clockwise increases the speed.

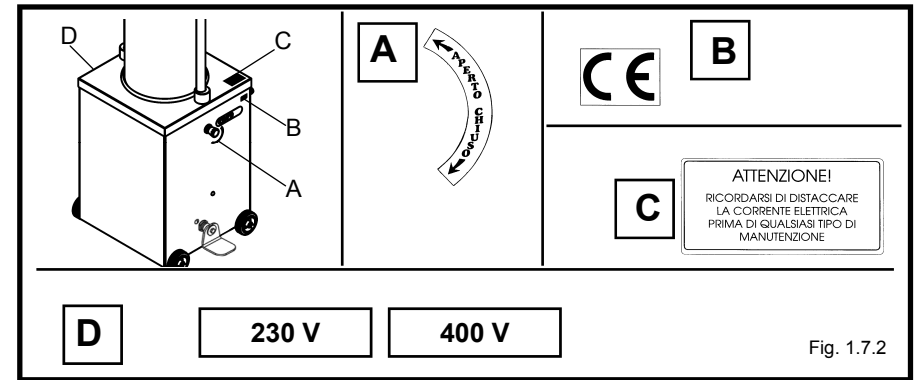

Fig. 1.7.2

1.8 - Safety protections and devices

ATTENTION!

Before proceeding to using the machine make sure the safety devices are whole and in the correct place. At the beginning of every work shift check that they are present and working correctly. If that is not the case warn the person in charge of maintenance.

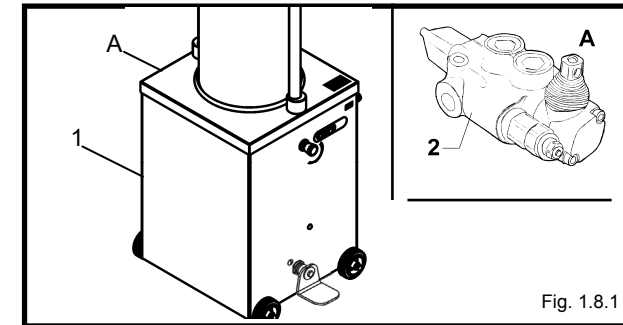

Fig. 1.8.1

1. Protection carters for the electrical and hydraulic components.
2. Safety valve.
Inside the machine there is a maximum pressure valve that limits the piston pushing power, fig. 1.8.1.

ATTENTION!

Never mishandle the safety devices for any reason.

1.9 - Work stations

The correct work station that the operator must occupy to optimize the work of the sack filling machine is indicated in fig. 1.9.1.

10 - Vibrations

The vibrations that the machine transmits to the counter are not important.

2 Technical features

2.1 - Main parts

To facilitate understanding the manual the main machine parts are listed and shown in the following fig. 2.1.1.

- 1 Command pedal
- 2 Product outlet made of AISI 304 stainless steel
- 3 Pushbutton panel
- 4 Work speed adjustment tap
- 5 Mixture carrying cylinder made of AISI 304 stainless steel
- 6 AISI 304 stainless steel solid steel structure
- 7 AISI 304 stainless steel cover
- 8 Cover blocking ring nuts

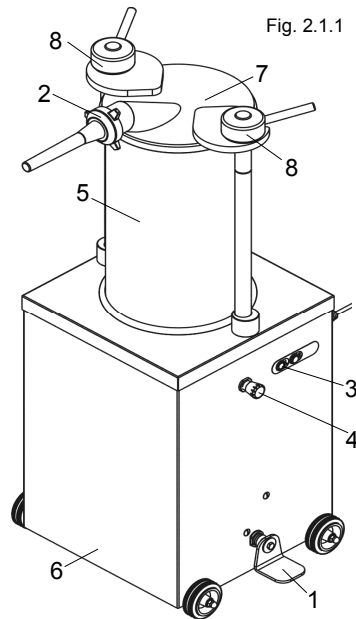
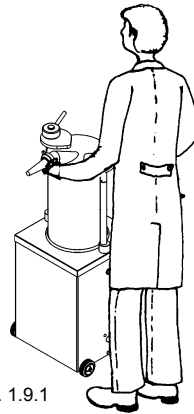

Fig. 1.9.1



Check the integrity of the package when it is received.

If there is damage to the package sign the delivery note with the transporter with an annotation, for ex.:

"I accept, with the reservation..." and then the reason.

Once the package has been opened in the presence of the components of the machine that are really damaged, make a report to the shipping agent within three days of the date indicated on the documents.

3.3 - Installation

ATTENTION!

The area where the machine will be installed must be flat and solid.

Furthermore place the machine keeping enough space around it.

This enables maneuvering it better during work phases and guarantees access during future maintenance interventions.

Prearrange the proper lighting around the machine to guarantee the correct visibility for the operator who must use the machine.

3.3.1 - Disposing of the packages

Components making up the package such as cardboard, nylon, wood are products comparable to solid urban trash. They can therefore be disposed of freely.

Nylon is a pollutant material that if burnt produces toxic fumes. Do not burn and do not throw away in the environment; dispose of it according to laws in force.

If the machine is delivered to countries where particular laws exist, dispose of the packages according to what is prescribed by the laws in force.

3.3.2 - Moving the machine

ATTENTION!

Lift the machine with a forklift that has the proper capacity.

Check the stability and the positioning of the load on the forks, in particular along accidental, inclined or slippery paths. During movement keep the load as low as possible to guarantee both greater stability and visibility.

Widen the forks of the lift to stabilize the hold as much as possible.

3.4 - Connecting the electrical system

Connect a 16 Ampere plug, which is not provided by the supplier, to the electrical feeding cable.

ATTENTION!

Check that the electrical feeding line corresponds to the value shown on the machine identification plate. Every intervention must be carried out only by specialized and personnel who are authorized by the person in charge. Make the connection to a supply mains which has efficient grounding.

2.5 - Hydraulic diagram

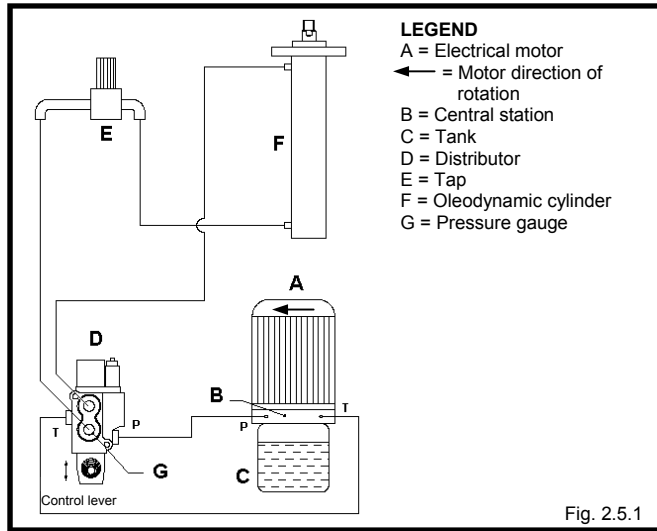

3 Testing, transport, delivery and installation

3.1 - Testing

The machine you have has been tested at our factories to check the correct running and adjustment.

3.2 - Delivery and moving the machine

All the material sent has been carefully checked before delivery to the shipping company. With the exception of different agreements with the client or particularly expensive transport, the machine will be wrapped in nylon and cardboard. The package dimensions are shown in fig. 3.2.

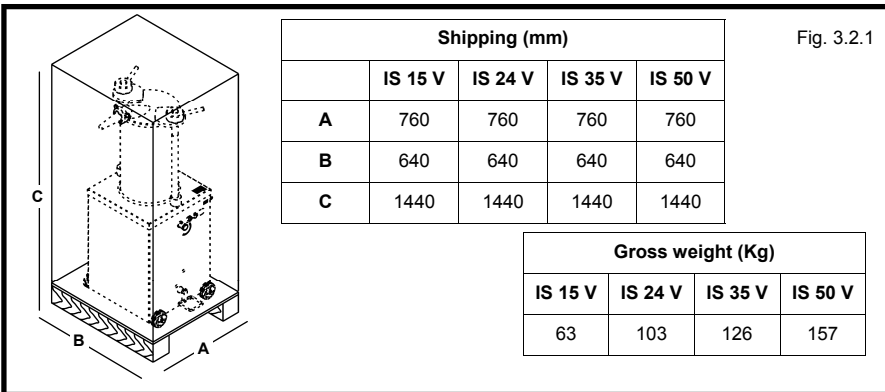

2.2 - Technical features

MODEL		IS 15 V	IS 24 V	IS 35 V	IS 50 V
Motor	Hp	0,75	0,75	0,75	0,75
Feed	V	230-400-50 Hz	230-400-50 Hz	230-400-50 Hz	230-400-50 Hz
Cylinder capacity	Lt	15	24	35	55
Cylinder length	mm	495	460	460	520
Cylinder diameter	mm	200	260	320	380
Piston run	mm	430	380	380	440
Min. emptying speed	Min	2' 11"	2' 02"	7' 46"	6'
Max. emptying speed	Sec	59"	51"	51"	75"
Piston return speed	Sec	35"	32"	33"	32"
Outfitted funnels	Mm Ø	10-18-25	10-18-25	10-18-25	10-18-25

2.3 - Dimensions and weight of the machine

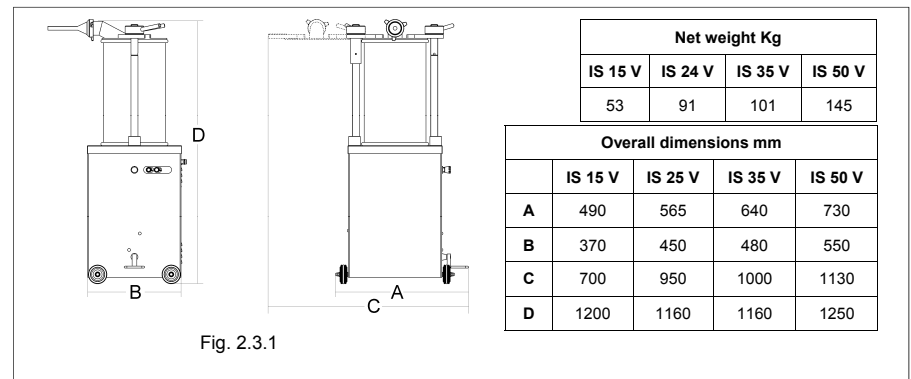

2.4 - Electrical diagrams

2.4.1 Single phase electrical diagram

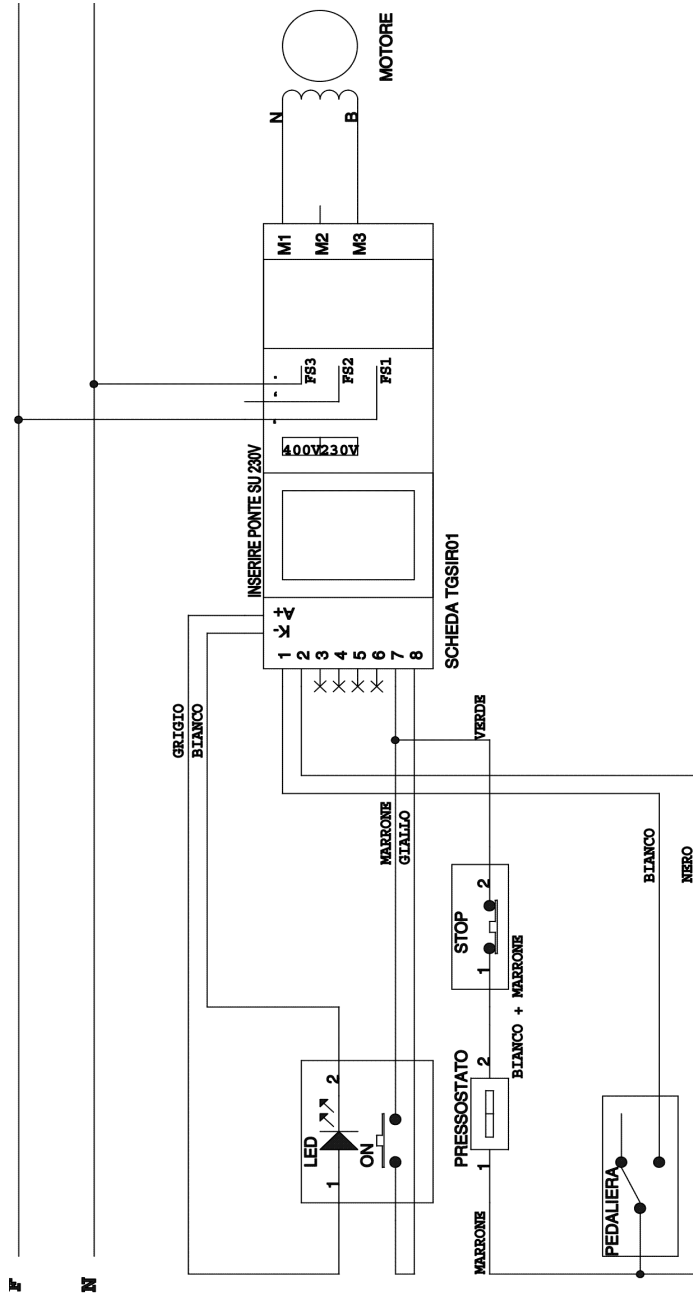

Fig. 2.4.1

2.4.2 Three-phase electrical diagram

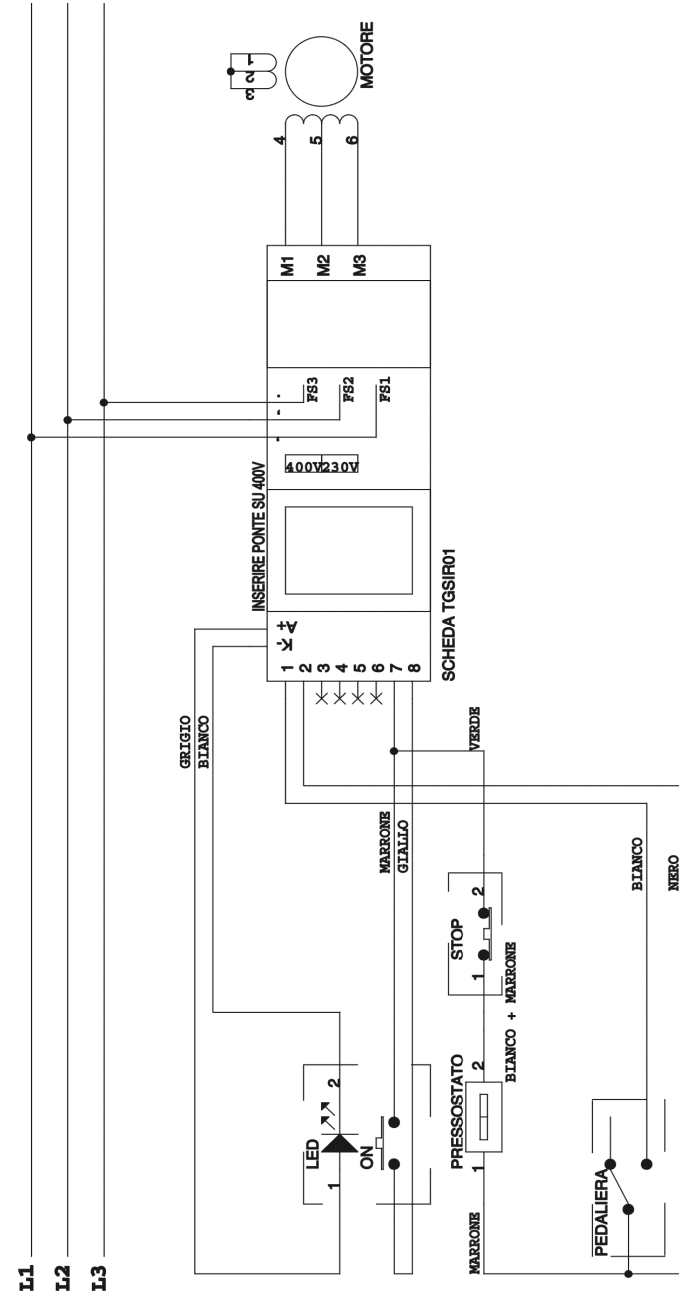

Fig. 2.4.2