

Packaging Contents

Please identify and check to ensure that all spare parts are ready before installation.

- Items Included
- Items NOT Included

| PART# | DESCRIPTION | QTY.(PCS) |
|-------|-------------------|-----------|
| 1 | Top shelf | 1 |
| 2 | Under shelf | 1 |
| 3 | Leg | 4 |
| 4 | Component of rack | 2 |
| 5 | Post | 2 |
| 6 | Washer | 4 |
| 7 | Screw-M8 | 4 |

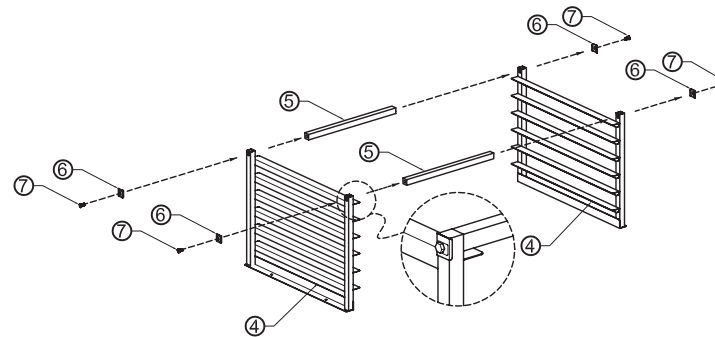

1

Step 1

Connect the 2 ends of the rack together using the included posts and hardware

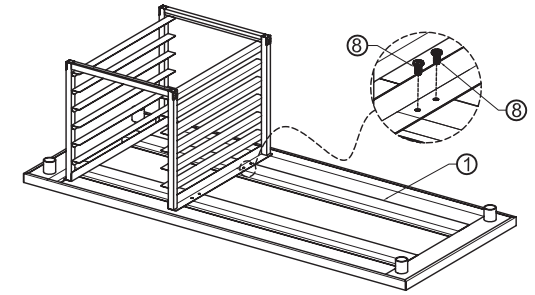

2

Step 2

Flip table over and align the rack on the table's hat channels, placing it in the position where you want it to mount. Use the predrilled holes on the rack as a guide to mark and drill pilot holes into the channels, being careful not to drill through the tabletop. Tighten the rack into place using sheet metal screws.

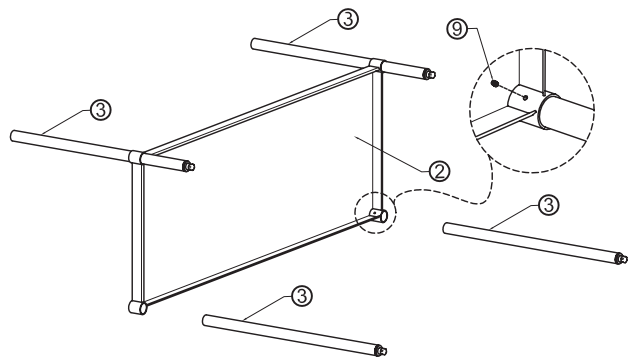

3

Step 3

Attach the legs and under-shelf to your table per manufacturer's instructions

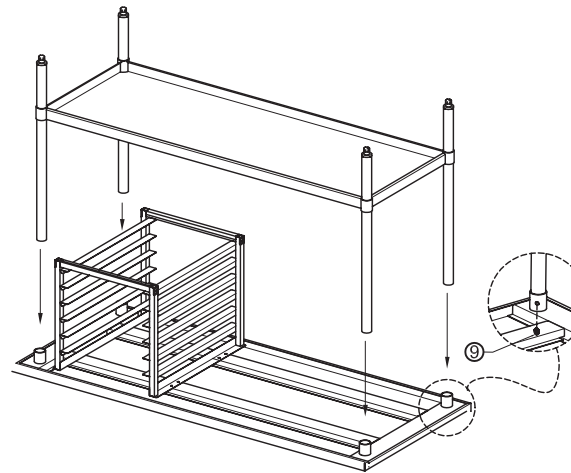

4

Step 4

Put the under-shelf into top shelf.

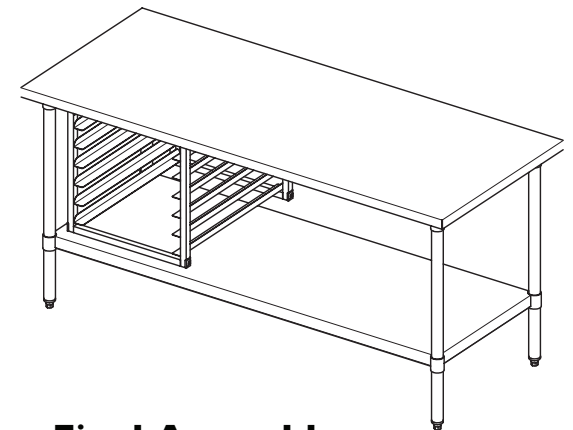

Final Assembly