

**2.5GALLON 120VOLT  
WATER HEATER**

FOR POTABLE WATER HEATING ONLY NOT SUITABLE FOR SPACE HEATING

**#600PHSHEATER**

# SAFE INSTALLATION, USE AND SERVICE

Your safety and the safety of others is extremely important in the installation, use, and servicing of this water heater.

Many safety-related messages and instructions have been provided in this manual and on your own water heater to warn you and others of a potential injury hazard. Read and obey all safety messages and instructions throughout this manual. It is very important that the meaning of each safety message is understood by you and others who install, use, or service this water heater.



This is the safety alert symbol. It is used to alert you to potential personal injury hazards. Obey all safety messages that follow this symbol to avoid possible injury or death.



## DANGER

**DANGER** indicates an imminently hazardous situation which, if not avoided, could result in death or injury.



## WARNING

**WARNING** indicates a potentially hazardous situation which, if not avoided, could result in death or injury.



## CAUTION

**CAUTION** indicates a potentially hazardous situation which, if not avoided, could result in death or injury.



## CAUTION

**CAUTION** used without the safety alert symbol indicates a potentially hazardous situation which, if not avoided, could result in property damage.

All safety messages will generally tell you about the type of hazard, what can happen if you do not follow the safety message, and how to avoid the risk of injury.

The California Safe Drinking Water and Toxic Enforcement Act requires the Governor of California to publish a list of substances known to the State of California to cause cancer, birth defects, or other reproductive harm, and requires businesses to warn of potential exposure to such substances.

This product contains a chemical known to the State of California to cause cancer, birth defects, or other reproductive harm. This appliance can cause low level exposure to some of the substances listed, including formaldehyde.

## IMPORTANT DEFINITIONS

- **Qualified Installer:** A qualified installer must have ability equivalent to a licensed tradesman in the fields of plumbing and electrical installation of these appliances. This would include a thorough understanding of the requirements of the National Electrical Code and they relate to the installation of electric water heaters. The qualified installer must have a thorough understanding of the water heater Instruction Manual.
- **Service Agency:** A service agency also must have ability equivalent to a licensed tradesman in the fields of plumbing and electrical installation of these appliances. This would include a thorough understanding of the requirements of the National Electrical Code and they relate to the installation of electric water heaters. The service agency must have a thorough understanding of the water heater Instruction Manual.

# GENERAL SAFETY

## ⚠ WARNING



Read and understand this instruction manual and safety messages before installing, operating, or servicing this water heater.

Failure to follow these instructions and safety messages could result in death or serious injury.

This manual must remain with water heater.

## ⚠ CAUTION

Improper installation and use may result in property damage.

- Do not operate water heater if flood damaged.
- Inspect and replace anode.
- Install in location with drainage.
- Fill tank with water before operation.
- Be alert for thermal expansion.

Refer to this manual for installation and service.

## ⚠ WARNING

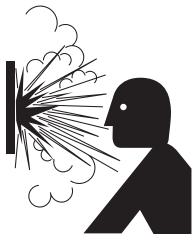

### Explosion Hazard

- Overheated water can cause water tank explosion.
- Properly sized temperature and pressure relief valve must be installed in opening provided.

## ⚠ WARNING



- Before removing any access panels or servicing the water heater, make sure the electrical supply to the water heater is turned "OFF".
- Failure to do this could result in death, serious bodily injury, or property damage.

## ⚠ DANGER



### Fire Hazard/Electrical Shock Hazard

Do not use an extension cord set with this heater. Use of an extension cord will cause overheating, fire, and electrical shock.

If no receptacle is available adjacent to the water heater, contact a qualified electrician to have one properly installed.

## ⚠ DANGER

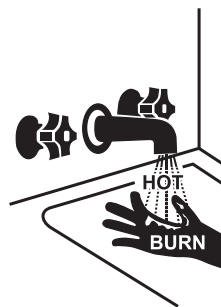

Water temperature over 125°F (52°C) can cause severe burns instantly resulting in severe injury or death.

Children, the elderly, and the physically or mentally disabled are at highest risk for scald injury.

Feel water before bathing or showering.

Temperature limiting valves are available. Read this instruction manual for safe temperature setting.

## ⚠ WARNING



### Fire Hazard/Electrical Shock Hazard

Do not use this water heater with any voltage other than shown on the model rating plate.

Failure to use the correct voltage shown on the model rating plate could result in death, serious bodily injury, or property damage.



# INTRODUCTION

Thank You for purchasing this water heater. Properly installed and maintained, it should give you years of trouble free service.

Abbreviations Found In This Instruction Manual:

- ANSI-American National Standards Institute
- AS ME-American Society of Mechanical Engineers
- NFPA-National Fire Protection Association
- UL-Underwriters Laboratories Inc.

## PREPARING FOR THE INSTALLATION

1. Read the "General Safety" section of this manual first and then the entire manual carefully. If you don't follow the safety rules, the water heater will not operate properly. It could cause DEATH, SERIOUS BODILY INJURY, AND/OR PROPERTY DAMAGE. This manual contains instructions for the installation, operation, and maintenance of the electric water heater. It also contains warnings throughout the manual that you must read and understand. All warning and all instructions are essential to the proper operation of the water heater and your safety. **READ THE ENTIRE MANUAL BEFORE ATTEMPTING TO INSTALL OR OPERATE THE WATER HEATER.**
2. The installation must conform with these instructions and the local code authority having jurisdiction and the requirements of the power company. In the absence of local code requirements follow NFPA-70, the National Electrical Code(current edition), which may be ordered from: National Fire Protection Association, 1 Batterymarch Park, Quincy, Ma 02269.
3. If after reading this manual you have any questions or do not understand any portion of the instructions, call the local utility or the manufacturer whose name appears on the rating plate.
4. Carefully plan your intended placement of the water heater. **INSTALLATION OR SERVICE OF THIS WATER HEATER REQUIRES ABILITY EQUIVALENT TO THAT OF A LICENSED TRADESMAN IN THE FIELD INVOLVED. PLUMBING AND ELECTRICAL WORK ARE REQUIRED.**
5. Examine the location to ensure the water heater complies with the "Facts to Consider About the Location" section in this manual.
6. For California installation this water heater must be braced, anchored, or strapped to avoid falling or moving during an earthquake, see instructions for correct installation procedures. Instructions may be obtained from California Office of the State Architect, 400P Street, Sacramento, CA 95814.
7. Massachusetts Code requires this water heater to be installed in accordance with Massachusetts 248-CMR 2.00: State Plumbing Code and 248-CMR5.00.

# TABLE OF CONTENTS

<b>SAFE INSTALLATION, USE AND SERVICE</b> .....	2
<b>GENERAL SAFETY</b> .....	3
<b>INTRODUCTION</b> .....	4
Preparing for the Installation .....	4
<b>TABLE OF CONTENTS</b> .....	5
<b>TYPICAL INSTALLATION</b> .....	6
<b>MIXING VALVE USAGE</b> .....	6
<b>MATERIALS AND BASIC TOOLS NEEDED</b> .....	7
Deciding on the Type of Installation.....	7
<b>LOCATING THE NEW WATER HEATER</b> .....	8
Facts to Consider About Location .....	8
Insulation Blankets.....	8
<b>IMPORTANT SAFETY INSTRUCTIONS</b> .....	8
<b>INSTALLING THE NEW WATER HAETER</b> .....	9
Mounting .....	9
Water Piping.....	9-10
Water Piping Pressure Test.....	10
Temperature-Pressure Relief Valve .....	10-11
Filling the Water Heater .....	11
<b>WIRING DIAGRAM</b> .....	12
<b>WIRING</b> .....	13
<b>TEMPERATURE REGULATION</b> .....	14
Temperature Adjustment .....	14
<b>FOR YOUR INFORMATION</b> .....	15
Thermal Expansion .....	15
Operation Conditions .....	15
<b>PERIODIC MAINTENANCE</b> .....	16
Anode Rod Inspection.....	16
Temperature-Pressure Relief Valve Operation .....	16
Draining.....	16
Removing Front Panel.....	16-17
Thermostat Removal/Replacement .....	17
Element Cleaning/Replacement .....	17-18
High Limit Switch Removal and Replacement .....	18
Service .....	18
<b>LEAKAGE CHECKPOINTS</b> .....	19
<b>TROUBLESHOOTING GUIDELINES</b> .....	20
<b>REPAIR PARTS LIST</b> .....	21
<b>NOTES</b> .....	22

Everything you need to know is contained in this fully illustrated Installation Guide. For most of you, this simple procedure booklet is all that's needed. However, if necessary you can get help from our Customer Service Representatives. They are there to help, with advice and direction. Call our toll-free number. It's your hotline to fast help.

**IMPORTANT:** Do not return this heater to the place of purchase unless you have called the number listed below first.

**ALL TECHNICAL AND WARRANTY QUESTIONS: SHOULD BE DIRECTED TO THE LOCAL DEALER FROM WHOM THE WATER HEATER WAS PURCHASED. IF YOU ARE UN SUCCESSFUL, PLEASE WRITE TO THE COMPANY LISTED ON THE RATING PLATE ON THE WATER HEATER**  
**KEEP THIS MANUAL IN THE POCKET ON THE WATER HEATER FOR FUTURE REFERENCE WHEN EVER MAINTENANCE ADJUSTMENT OR SERVICE IS REQUIRED.**

# TYPICAL INSTALLATION

## ⚠ DANGER



Fire Hazard/Electrical Shock  
Hazard Explosion Hazard

### THIS WATER HEATER MUST:

- Be properly grounded.
- Be connected to a properly grounded electrical supply with the proper voltage rating as stated on the water heater data plate.
- Have proper overload fuse or breaker.

Failure to follow these instructions can result in a fire, explosion or electrical shock causing property damage, personal injury or death.

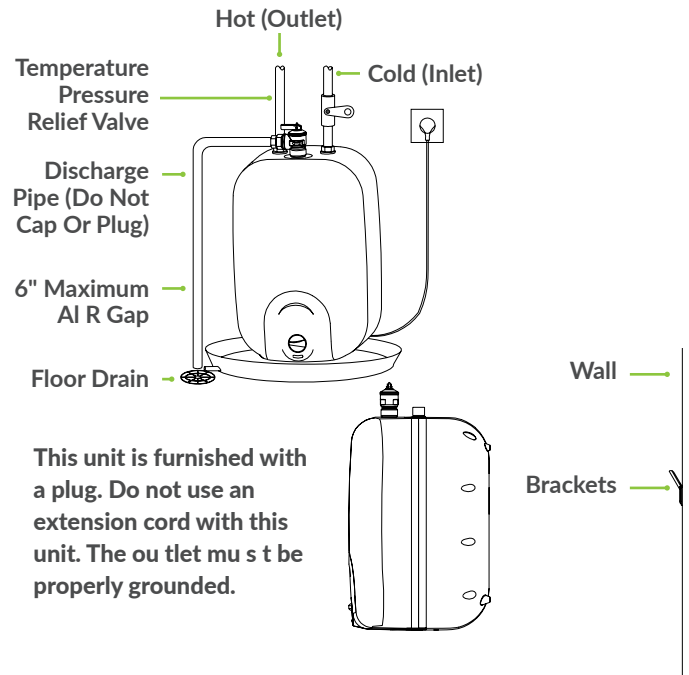

This unit is furnished with a plug. Do not use an extension cord with this unit. The outlet must be properly grounded.

FIGURE 01.

# MIXING VALVE USAGE

Water (Potable) heating: All models are considered suitable for water (potable) heating only.

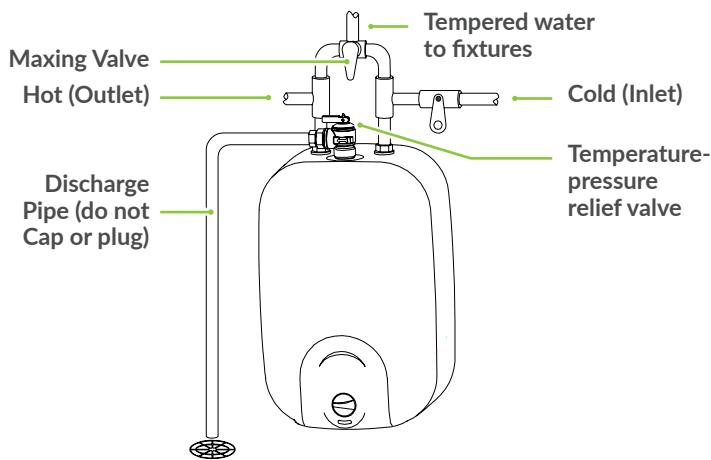
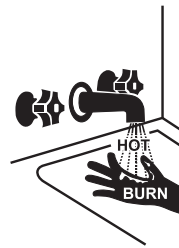

FIGURE 02.

## ⚠ WARNING



Water temperature over 125°F (52°C) can cause severe burns instantly resulting in severe injury or death.

Children, the elderly, and the physically or mentally disabled are at highest risk for scald injury. Feel water before bathing or showering.

Temperature limiting valves are available. Read this instruction manual for safe temperature setting.

**HOTTER WATER CAN SCALD:** Water heaters are intended to produce hot water. Water heated to a temperature which will satisfy space heating, clothes washing, and other sanitizing needs can scald and permanently injure you upon contact. Some people are more likely to be permanently injured by hot water than others. These include the elderly, children, the infirm, or physically/mentally disabled. If anyone using hot water in your home fits into one of these groups or if there is a local code or state law requiring certain temperature water at the hot water tap, then you must take special precautions. In addition to using the lowest possible temperature setting that satisfies your hot water needs, a means such as a mixing valve, should be used at the hot water taps used by these people or at the water heater. Mixing valves are available from your local plumbing contractor. Consult a Qualified Installer or Service Agency. Follow mixing valve manufacturer's instructions for installation of the valves. Before changing the factory setting on the thermostat, read the "Temperature Regulation" section in this manual.

# MATERIALS AND BASIC TOOLS NEEDED

## DECIDING ON THE TYPE OF INSTALLATION

There are typically two different types of installation. The installation section of this manual has been broken into these two methods. Look at your old water heater installation to determine which type of installation you have. After finding out what type of installation you have, look at these options:

**Section A**  
Galvanized Pipe or Copper (Sweat) Piping

The original piping is galvanized pipe or sweat copper and you are going to use a "Water Heater Installation Kit".

**Installation Kit or Individual Parts**

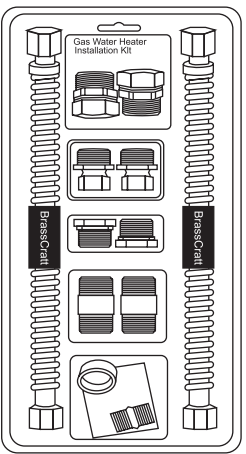

**Electric Installation Kit**

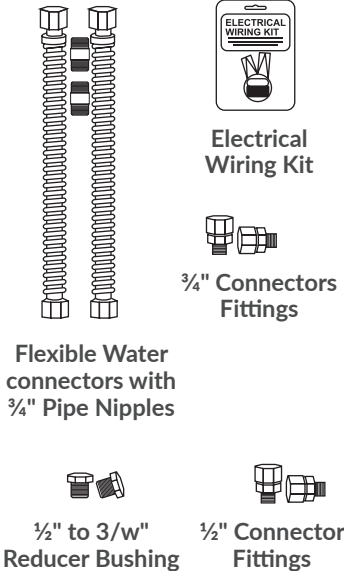

**Flexible Water connectors with 3/4" Pipe Nipples**

**1/2" to 3/w" Reducer Bushing**

**3/4" Connector Fittings**

**1/2" Connector Fittings**

### CHECK YOUR TOOLS

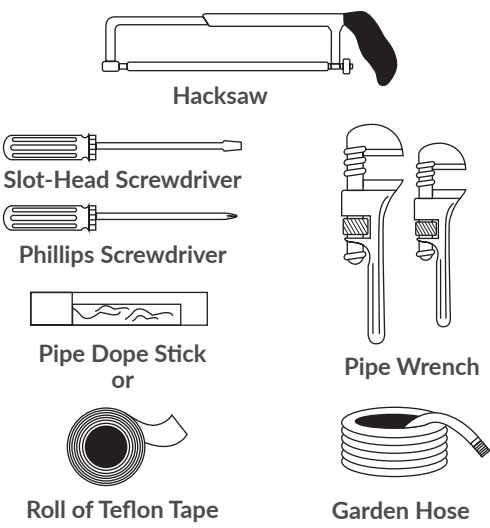

**Hacksaw**

**Slot-Head Screwdriver**

**Phillips Screwdriver**

**Pipe Dope Stick or**

**Roll of Teflon Tape**

**Pipe Wrench**

**Garden Hose**

**Section B**  
Copper (Sweat) Piping

The original piping is copper sweat and you are going to reconnect with sweat joints.

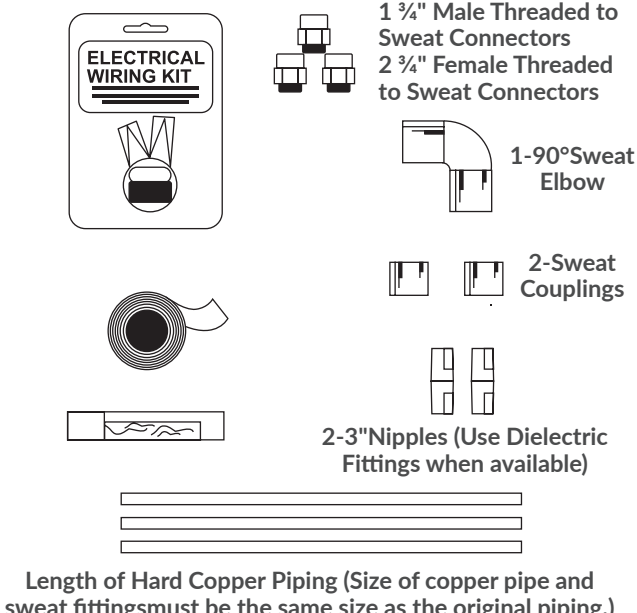

**1 3/4" Male Threaded to Sweat Connectors**

**2 3/4" Female Threaded to Sweat Connectors**

**1-90°Sweat Elbow**

**2-Sweat Couplings**

**2-3"Nipples (Use Dielectric Fittings when available)**

**Length of Hard Copper Piping (Size of copper pipe and sweat fittings must be the same size as the original piping.)**

### CHECK YOUR TOOLS

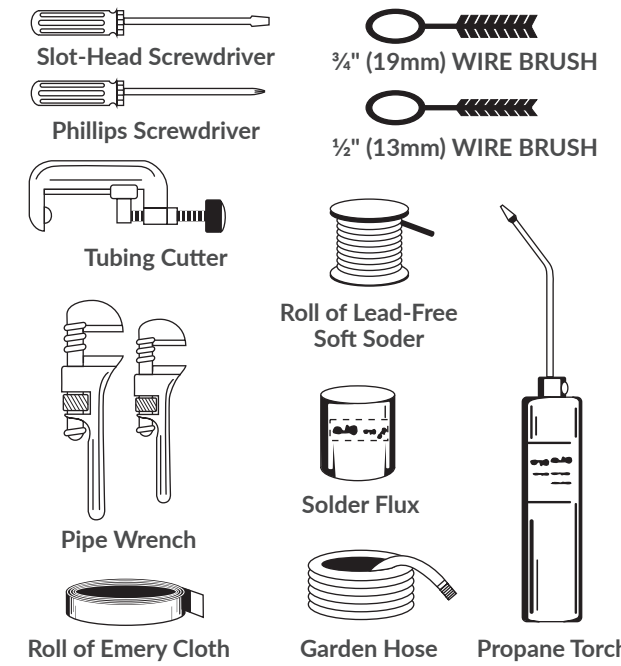

**Slot-Head Screwdriver**

**Phillips Screwdriver**

**3/4" (19mm) WIRE BRUSH**

**1/2" (13mm) WIRE BRUSH**

**Tubing Cutter**

**Roll of Lead-Free Soft Soder**

**Pipe Wrench**

**Solder Flux**

**Roll of Emery Cloth**

**Garden Hose**

**Propane Torch**

# LOCATING THE NEW WATER HEATER

## Facts To Consider About The Location

### ⚠ CAUTION

#### Property Damage Hazard

- All water heater eventually leak
- Do not install without adequate drainage

Carefully choose an indoor location for the new water heater, because the placement is very important consideration for the safety of the occupants in the building and for the most economical use of the appliance.

Whether replacing an old water heater or putting the water heater in a new location, the following critical points must be observed:

1. Select a location as close as practical or centralized to the point of use. The water heater should be located in an area not subject to freezing temperatures.
2. Selected location must provide adequate clearances for removing the front cover in order to service parts such as the thermostat, element, temperature sensor, anode, and high limit reset. Adequate clearance for servicing this appliance should be considered before installation, such as operating the relief valve, etc.
3. The water heater should be located so it is not subject to physical damage by moving vehicles or area flooding.
4. The selected wall or cabinet must be capable of supporting at least two times the weight of the water heater when filled with water (77 lbs).
5. The water heater must be installed in a vertical position with water inlet and outlet connections facing upwards and easily accessible.

Installation of the water heater must be accomplished in such a manner that if the tank or any connections should leak, the flow will not cause damage to the structure. For this reason, it is not advisable to install the water heater in an attic or upper floor.

When such locations cannot be avoided, a suitable drain pan should be installed under the water heater. Drain pans are

available from your local plumbing contractor. Such a drain pan must have a minimum length and width of at least 2 inches (51 mm) greater than the water heater dimensions and must be piped to an adequate drain.

Water heater life depends upon water quality, water pressure, water usage, water temperature, and the environment in which the water heater is installed. Water heaters are sometimes installed in locations where leakage may result in property damage, even with the use of a drain pan piped to a drain.

However, unanticipated damage can be reduced or prevented by a leak detector or water shut-off device used in conjunction with a piped drain pan. These devices are available from some plumbing supply wholesalers and retailers, and detect and react to leakage in various ways:

- Sensors mounted in the drain pan that trigger an alarm or turn off the incoming water to the water heater when leakage is detected.
- Sensors mounted in the drain pan that turn off the water supply to the entire home when water is detected in the drain pan.
- Water supply shut-off devices that activate based on the water pressure differential between the cold water and hot water pipes connected to the water heater.

#### INSULATION BLANKETS

Insulation blankets are available to the general public for external use on electric water heaters but are not necessary with this product. The purpose of an insulation blanket is to reduce the standby heat loss encountered with storage tank heaters.

Should you choose to apply an insulation blanket to this heater, you should follow these instructions below. Failure to follow these instructions can result in fire, serious personal injury, or death.

Do not cover the temperature and pressure relief (T&P) valve with an insulation blanket.

Do not cover the instruction manual. Keep it on the side of the water heater or nearby for future reference.

Do obtain new warning and instruction labels for placement on the blanket directly over the existing labels.

# IMPORTANT SAFETY INSTRUCTIONS

### ⚠ DANGER



#### Fire Hazard/Electrical Shock Hazard

When using electrical appliances, basic safety precautions to reduce the risk of fire, electric shock, or injury to persons should be followed.

1. READ ALL INSTRUCTIONS BEFORE USING THIS WATER HEATER.
2. This water heater must be grounded. Connect only to properly grounded outlet. See **GROUNDING INSTRUCTIONS** found in the **WIRING** section of this manual.
3. Install or locate this water heater only in accordance with the provided installation instructions.
4. Use this water heater for its intended use as described in this manual.
5. Do not use an extension cord set with this water heater. If no receptacle is available adjacent to the water heater, contact a qualified electrician to have one properly installed.
6. As with any appliance, close supervision is necessary when used by children.
7. Do not operate this water heater if it has a damaged cord or plug, if it is not working properly, or if it has been damaged or dropped.
8. This water heater should be serviced only by qualified service personnel. Contact nearest authorized service facility for examination, repair, or adjustment.



# INSTALLING THE NEW WATER HEATER

## MOUNTING

### MOUNTING-DRYWALL (HOLLOW WALL)

1. The selected wall or cabinet must be capable of supporting double the weight of the unit when completely full of water(77lbs).
2. The installation area must provide adequate clearances for removal of the front panel and servicing the unit.
3. Locate the wall studs in the area where the unit is to be mounted.
4. Cut two sections of 1/2 inch plywood or equivalent material 3 inches in height. The length of each section should be sufficient to span the width of the wall studs. See Figure 3A.
5. Use appropriately sized nails or wood screws to attach the two wall supports to the wall as show in Figure 3A.
6. Drill two 13/32 inch holes in the upper wall support NOTE: The holes must be level.
7. Insert the hollow wall anchors into the drilled holes. Place the wall bracket over the anchors and screw the two Phillips head screws down tight against the bracket.

### MOUNTING-MASONRY WALL (SOLID WALL)

1. The selected wall or cabinet must be capable of supporting double the weight of the unit when completely full of water(77lbs ).
2. The installation area must provide adequate clearances for removal of the front panel and servicing the unit.
3. Drill two 13/32 inch holes in the masonry wall. NOTE: The holes must be level and at least 3-1 /2 inches deep.
4. Insert the masonry wall anchors into the drilled holes. Place the wall bracket over the anchors and screw the two Phillips head screws tight against the bracket.

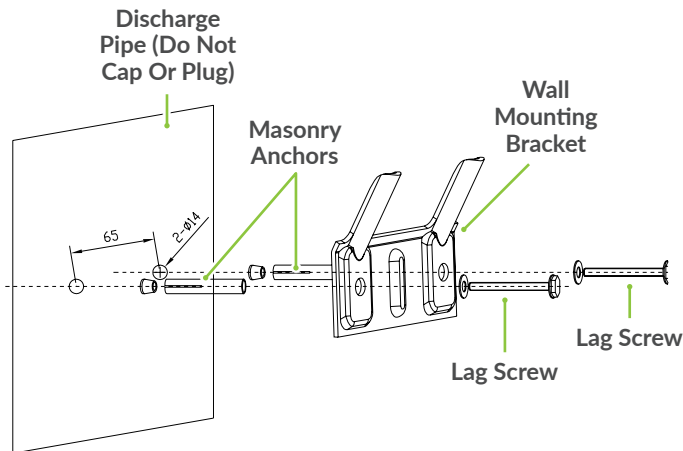

FIGURE 03A.

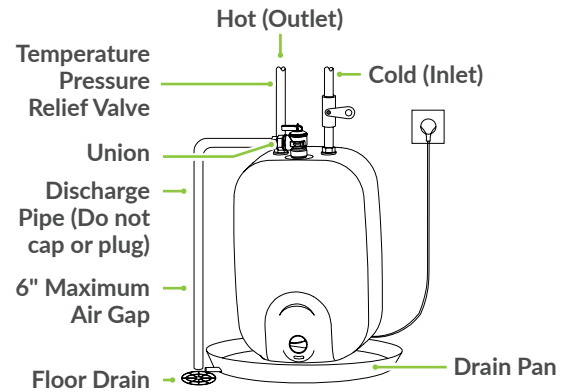
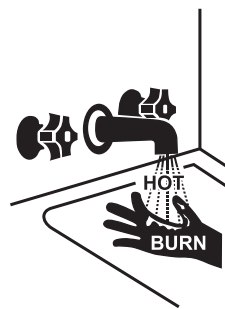

FIGURE 03B.

## WATER PIPING

### ⚠ DANGER



Water temperature over 125°F (52°C) can cause severe burns instantly resulting in severe injury or death.

Children, the elderly, and the physically or mentally disabled are at highest risk for scald injury.

Feel water before bathing or showering.

Temperature limiting valves are available. Read this instruction manual for safe temperature setting.

### HOTTER WATER CAN SCALD:

Water heaters are intended to produce hot water. Water heated to a temperature which will satisfy space heating, clothes washing, dish washing, cleaning and other sanitizing needs can scald and permanently injury you upon contact. Some people are more likely to be permanently injured by hot water than others. These include the elderly, children, the infirm, or physically/mentally disabled. If anyone using hot water in your home fits into one of these groups or if there is a local code or state law requiring certain temperature water at the hot water tap, then you must take special precautions. In addition to using the lowest possible temperature setting that satisfies your hot water needs, a means such as a mixing valve should be used at the hot water taps used by these people or at the water heater. Valves for reducing point of use temperature by mixing cold and hot water are also available.

Consult a Qualified Installer or Service Agency. Follow manufacturer's instructions for installation of the valves. Before changing the factory setting on the thermostat, read the "Temperature Regulation" section in this manual.

## ⚠ WARNING

### Toxic Chemical Hazard

- Do not connect non-potable water system

This water heater shall not be connected to any heating systems or components used with a non potable water heating appliance. Toxic chemicals, such as those used for boiler treatment shall not be introduced into this system.

Water supply system may, because of such events as high line pressure, frequent cut-offs, the effects of water hammer among others, have installed devices such as pressure reducing valves, check valves, back flow preventers, etc. to control these types of problems. When these devices are not equipped with an internal by-pass, and no other measures are taken, the devices cause the water system to be closed. As water is heated, it expands(thermal expansion) and closed systems do not allow for the expansion of heated water.

The water within the water heater tank expands as it is heated and increases the pressure of the water system. If the relieving point of the water heater's temperature-pressure relief valve is reached, the valve will relieve the excess pressure. The temperature-pressure relief valve is not limited for the constant relief of thermal expansion. This is an unacceptable condition and must be corrected.

It is recommended that any devices installed which could create a closed system have a by-pass and/or the system have an expansion tank or device to relieve the pressure built by thermal expansion in the water system. Expansion tanks are available for ordering through a local plumbing contractor. Contact the local water supplier and/or a service agency for assistance in controlling these situations.

**NOTE: To protect against untimely corrosion of hot and cold water fittings, it is strongly recommended that dielectric unions or couplings be installed on this water heater when connected to copper pipe.**

Figure 4 shows the typical attachment of the water piping to the water heater. The water heater is equipped with 1/2 inch NPT water connections.

## ⚠ CAUTION

### Property Damage Hazard

- Avoid water heater damage.
- Install thermal expansion tank if necessary.
- Do not apply heat to cold water inlet.
- Contact qualified installer or service agency.

**NOTE: If using copper tubing, older tubing to an adapter before attaching the adapter to the cold water inlet connection. Do not solder that cold water supply line directly to the cold water inlet, it will harm the dip tube and damage the tank.**

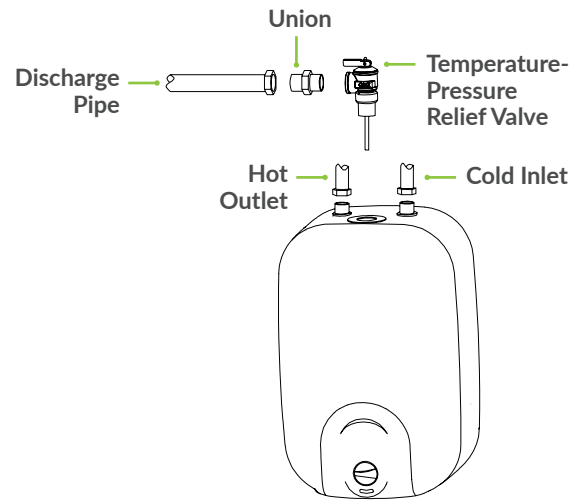

FIGURE 04.

## WATER PIPING PRESSURE TEST

This section is only for the manufacturer installing the water heater when the installation is to comply with H.U.D. Standards. When testing the water ways, H.U.D. Standards state:

"Water distribution system: All water piping in the water distribution system shall be subjected to a pressure test. The test shall be made by subjecting the system to air or water at 1 00psi for 15 minutes without loss of pressure. **When air pressure is used, the water heater shall not be connected during the test.**"

## ⚠ WARNING

### Air Pressure Hazard

- If water piping system is to be air pressure tested, the water heater must be disconnected from the water piping system.
- Failure to disconnect the water heater during air pressure testing of the water system could result in **DEATH, SERIOUS BODILY INJURY, OR PROPERTY DAMAGE.**

## TEMPERATURE-PRESSURE RELIEF VALVE

## ⚠ WARNING

### Explosion Hazard

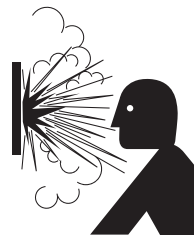

- Temperature-pressure relief valve must comply with ANSI Z21.22 and ASME code.
- Properly sized temperature-relief valve must be installed in opening provided.
- Can result in overheating and excessive tank pressure.
- Can cause serious injury or death.

This heater is provided with a properly certified combination temperature-pressure relief valve by the manufacturer.

The valve is certified by a nationally recognized testing laboratory that maintains periodic inspection of production of listed equipment of materials as meeting the requirements for Relief Valve for Hot Water Supply Systems, ANSI Z21.22 • CSA4.4, and the code requirements of ASME.

If replaced, the valve must meet the requirements of local codes, but not less than a combination temperature and pressure relief valve certified as indicated in the above paragraph.

The valve must be marked with a maximum set pressure not to exceed the marked hydrostatic working pressure of the water heater(150psi=1035kPa) and a discharge capacity not less than the water heater input rate as shown in the model rating plate.

**For safe operation of the water heater, the relief valve must not be removed from its designated opening nor plugged.**

The temperature-pressure relief valve must be installed directly into the fitting of the water heater designed for the relief valve. Provide tubing so that any discharge will exit only within 6 inches (153mm) above an adequate drain, or external to the building or structure. Be certain that no contact is made with any live electrical part. The discharge opening must not be blocked or reduced in size under any circumstances. Excessive length, over 30 feet (9.14m), or use of more than four elbows can cause restriction and reduce the discharge capacity of the valve.

No valve or other obstruction is to be placed between the relief valve and the tank. Do not connect tubing directly to discharge drain unless a 6 inch air gap is provided. The relief valve must be allowed to discharge water in sufficient quantities, should circumstances demand, to prevent bodily injury, hazard to life, or property damage. If the discharge pipe is not connected to a drain or other suitable means, the water flow may cause property damage.

## ⚠ CAUTION

### Water Damage Hazard

- Temperature-pressure relief valve discharge pipe must terminate at adequate drain.

### The Discharge Pipe:

- Shall not be smaller in size than the outlet pipe size of the valve, or have any reducing couplings or other restrictions.
- Shall not be plugged or blocked.
- Shall be of material listed for hot water distribution.
- Shall be installed so as to allow complete drainage of both the temperature-pressure relief valve, and the discharge pipe.
- Shall be installed so as to allow complete drainage of both the temperature-pressure relief valve, and the discharge pipe.
- Shall terminate at an adequate drain or external to the building or structure.
- Shall not have any shut-off valve between the relief valve and tank nor in the discharge pipe.

## ⚠ DANGER

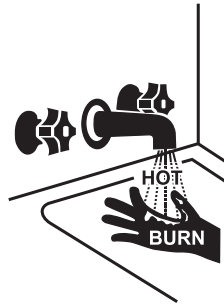

Water temperature over 125°F (52°C) can cause severe burns instantly resulting in severe injury or death.

Children, the elderly, and the physically or mentally disabled are at highest risk for scald injury.

Feel water before bathing or showering.

Temperature limiting valves are available. Read this instruction manual for safe temperature setting.

The temperature-pressure relief valve must be manually operated at least once a year. Caution should be taken to ensure that (1) no one is in front of or around the outlet of the temperature-pressure relief valve discharge line, and (2) the water manually discharged will not cause any bodily injury or property damage because the water may be extremely hot.

If after manually operating the valve, it fails to completely reset and continues to release water, immediately close the cold water inlet to the water heater, follow the draining instructions, and replace the temperature-pressure relief valve with a new one.

### FILLING THE WATER HEATER

## ⚠ CAUTION

### Property Damage Hazard

- Avoid water heater damage.
- Fill tank with water before operating.

Never use this water heater unless it is completely full of water. To prevent damage to the tank and heating element, the tank must be filled with water. Water must flow from the hot water faucet before turning "ON" electrical supply to the water heater. The manufacturer will not warrant any elements damaged by failure to follow instructions.

### To fill the water heater with water:

1. Open the cold water supply valve to the water heater.  
**NOTE: The cold water supply valve must be left open when the water heater is in use.**
2. To ensure complete filling of the tank, allow air to exit by opening the nearest hot water faucet. Allow water to run until a constant flow is obtained. This will let air out of the water heater and the piping.
3. Check all water piping and connections for leaks. Repair as needed.
4. Never alter or modify the certified construction of the water heater or its components, or bypass any safety features. Doing so voids all warranties.

# WIRING DIAGRAM

## ⚠ WARNING



- Before removing any access panels or servicing the water heater, make sure the electrical supply to the water heater is turned "OFF".
- Failure to do this could result in death, serious bodily injury, or property damage.

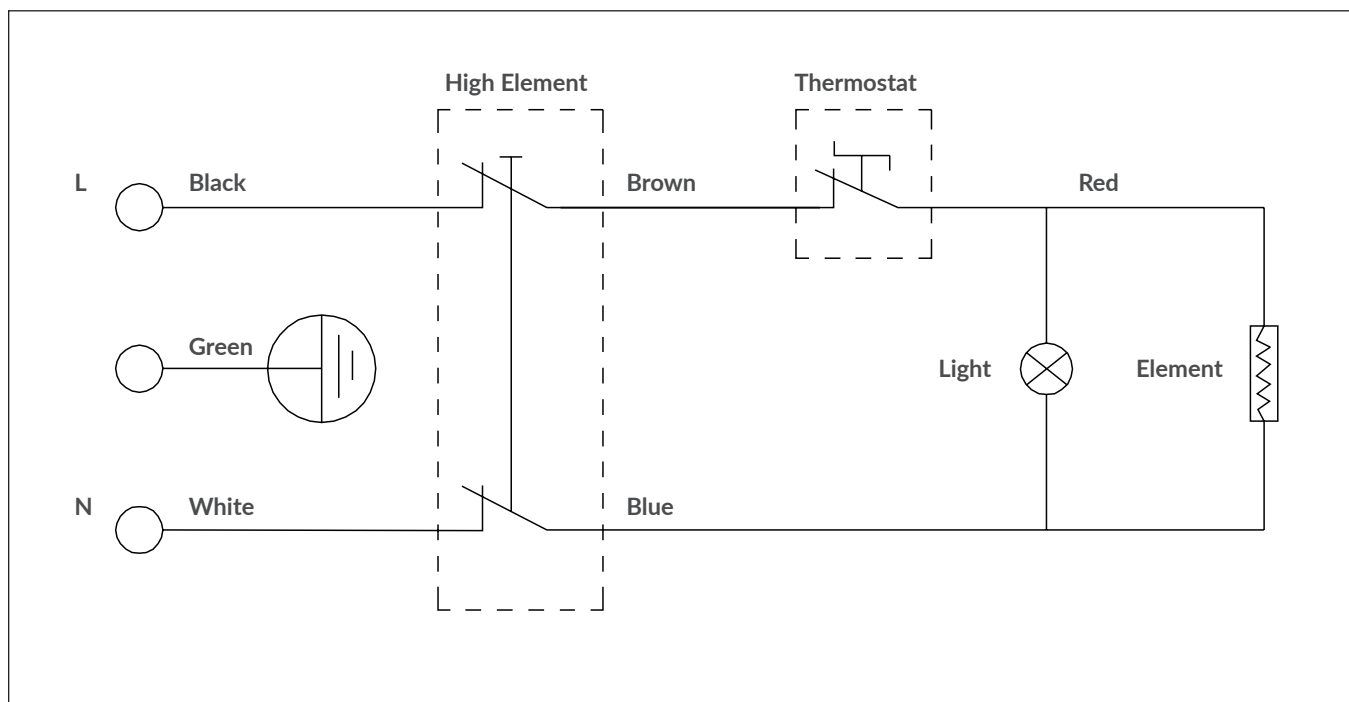

FIGURE 05.

# WIRING

## ⚠ CAUTION

Improper installation and use may result in property damage.

- Fill tank with water heater before operation.

Never use the water heater unless it is completely full of water. To prevent damage to the tank and the heating element, the tank must be filled with water. Water must flow from the hot water faucet before turning on the power.

## ⚠ WARNING



### Fire Hazard/Electrical Shock Hazard

- Do not use this water heater with any voltage other than shown on the model rating plate.
- Failure to use the correct voltage shown on the model rating plate could result in death, serious bodily injury, or property damage.

You must provide all wiring of the proper size outside of the water heater. You must obey the local codes and the electric company requirements when you install this wiring.

This water heater is supplied with a flexible, grounded power cord and connects to a standard three-wire 120 volt 60Hz grounded type outlet. If an outlet is not within reach of the power cord, contact a local electrician/electrical contractor or the local electric utility to have a properly sized circuit (including outlet, wiring and breaker) installed. NOTE: Check the water heater's data plate for power requirements.

If you are not familiar with the electric codes and practices, or if you have any doubt, even the slightest doubt, in your ability to connect the wiring to the water heater, obtain the service of a competent electrician. Contact a local electrical contractor and/or the local electric utility.

**WATER HEATERS EQUIPPED FOR ONE VOLTAGE ONLY:** This water heater is equipped for one type voltage only. Check the rating plate near the bottom access panel for the correct voltage. DO NOT use this water heater with any voltage other than the one shown on the models rating plate. Failure to use the correct voltage can cause problems which can result in DEATH, SERIOUS BODILY INJURY, OR PROPERTY DAMAGE. If you have any questions or doubts consult your electric company.

If wiring from your fuse box or circuit breaker box was aluminum for your old water heater, replace it with copper wire. If you wish to reuse the existing aluminum wire, have the connection at the water heater made by a competent electrician. Contact a local electrical contractor and /or the local electric utility.

# TEMPERATURE REGULATION

## ⚠ DANGER

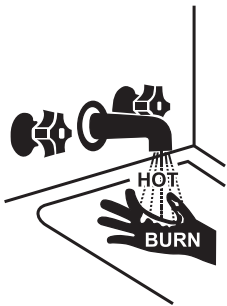

Water temperature over 125°F (52°C) can cause severe burns instantly resulting in severe injury or death.

Children, the elderly, and the physically or mentally disabled are at highest risk for scald injury.

Feel water before bathing or showering.

Temperature limiting valves are available. Read this instruction manual for safe temperature setting.

### HOTTER WATER CAN SCALD:

Water heaters are intended to produce hot water. Water heated to a temperature which will satisfy space heating, clothes washing, dish washing, cleaning and other sanitizing needs can scald and permanently injure you upon contact. Some people are more likely to be permanently injured by hot water than others. These include the elderly, children, the infirm, or physically/mentally disabled. If anyone using hot water in your home fits into one of these groups or if there is a local code or state law requiring certain temperature water at the hot water tap, then you must take special precautions. In addition to using the lowest possible temperature setting that satisfies your hot water needs, a means such as a mixing valve should be used at the hot water taps used by these people or at the water heater. Mixing valves are available from your local plumbing contractor. Follow manufacturer's instructions for installation of the valves. Before changing the factory setting on the thermostat, see Figure 6.

Never allow small children to use a hot water tap or to draw their own bath water. Never leave a child or handicapped person unattended in a bathtub or shower.

It is recommended that lower water temperatures be used to avoid the risk of scalding. It is further recommended, in all cases, that the water temperature thermostat be set for the lowest temperature which satisfies your hot water needs. This will also provide the most energy efficient operation of the water heater.

**KEEPING THE THERMOSTAT SETTING AT 120°F (49°C) OR LOWER WILL REDUCE THE RISK OF SCALDS.**

Figure 6 shows the approximate time-to-burn relationship for normal adult skin.

## TEMPERATURE ADJUSTMENT

### ⚠ WARNING



- Before removing any access panels or servicing the water heater, make sure the electrical supply to the water heater is turned "OFF".
- Failure to do this could result in death, serious bodily injury, or property damage.

### To change the temperature setting:

The white knob on the front of the water heater is the temperature control. When the "OFF" mark is aligned with the raised indicator arrow, the water heater is off. Turn the knob clockwise to increase the temperature, and counterclockwise to decrease the temperature. The knob is marked with circular indentations of increasing size. The larger the indentation, the higher the temperature setting. See Figure 6. The temperature range of this water heater is 68°F at the lowest setting and 158°F at the maximum setting. This water heater is shipped in the "OFF" position. Adjust the dial to the desired temperature.

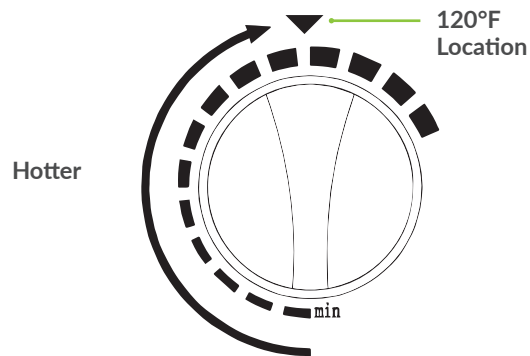

**TEMPERATURE SETTINGS**  
It is recommended that the dial be set lower whenever possible.

Temperature Setting	Time to Produce 2nd & 3rd degree burns on Adult Skin
158°F (70 °C)	About 1-1 /2 seconds
140°F (60°C)	Less than 5 seconds
130°F (54 °C)	About 30 seconds
120°F (49 °C)	More than 5 minutes

FIGURE 06.

# FOR YOUR INFORMATION

## THERMAL EXPANSION

### ⚠ CAUTION

#### Property Damage Hazard

- Avoid water heater damage.
- Install thermal expansion tank if necessary.
- Do not apply heat to cold water inlet.
- Contact qualified installer or service agency.

Water supply systems may, because of such events as high line pressure, frequent cut-offs, the effects of water hammer among others, have installed devices such as pressure reducing valves, check valves, back flow preventers, etc. to control these types of problems. When these devices are not equipped with an internal by-pass, and no other measures are taken, the devices cause the water system to be closed. As water is heated, it expands (thermal expansion) and closed systems do not allow for the expansion of heated water.

The water within the water heater tank expands as it is heated and increases the pressure of the water system. If the relieving point of the water heater's temperature-pressure relief valve is reached, the valve will relieve the excess pressure. The temperature-pressure relief valve is not intended for the constant relief of thermal expansion. This is an unacceptable condition and must be corrected. It is recommended that any devices installed which could create a closed system have a bypass and/or the system have an expansion in the water system. Expansion tanks are available for ordering through a local plumbing contractor. Contact the local water heater supplier or service agency for assistance in controlling these situations.

#### STRANGE SOUNDS

Possible noises due to expansion and contraction of some metal parts during periods of heat-up and cool-down do not necessarily represent harmful or dangerous conditions

## OPERATION CONDITIONS

#### WATER ODOR

In each water heater there is installed at least one anode rod (see parts section) for corrosion protection of the tank. Certain water conditions will cause a reaction between this rod and the water. The most common complaint associated with the anode rod is one of a "rotten egg smell" in the hot water. This odor is derived from hydrogen sulfide gas dissolved in the water. The smell is the result of four factors which must all be present for the odor to develop:

- A. A concentration of sulfate in the supply water.
- B. Little or no dissolved oxygen in the water.
- C. A sulfate reducing bacteria which has accumulated within the water heater (this harmless bacteria is nontoxic to humans).
- D. An excess of active hydrogen in the tank. This is caused by the corrosion protective action of the anode.

Smelly water may be eliminated or reduced in some water heater models by replacing the anode(s) with one of less active material, and then chlorinating the water heater tank and all hot water lines. Contact the local water heater supplier or service agency

for further information concerning an Anode Replacement and chlorination treatment; we can only suggest that chlorination or aeration of the water supply be considered to eliminate the water problem.

Do not remove the anode leaving the tank unprotected. By doing so, all warranty on the water heater tank is voided.

#### "AIR" IN HOT WATER FAUCETS

### ⚠ WARNING

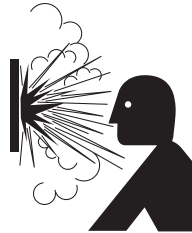

#### Explosion Hazard

- Flammable hydrogen gases may be present.
- Keep all ignition sources away from faucet when turning on hot water.

#### HYDROGEN GAS:

Hydrogen gas can be produced in a hot water system that has not been used for a long period of time (generally two weeks or more). Hydrogen gas is extremely flammable and explosive. To prevent the possibility of injury under these conditions, we recommend the hot water faucet, located farthest away be opened for several minutes before any electrical appliances which are connected to the hot water system are used (such as a dishwasher or washing machine). If hydrogen gas is present, there will probably be an unusual sound similar to air escaping through the pipe as the hot water faucet at the time it is open.

#### HIGHER WATER TEMPERATURE SHUT OFF SYSTEM

A non-adjustable high temperature limit control operates before steam temperatures are reached. The high limit switch must be reset manually when it operates. **BECAUSE THE HIGH LIMIT OPERATES ONLY WHEN ABNORMALLY HIGH WATER TEMPERATURES ARE PRESENT, IT IS IMPORTANT THAT A QUALIFIED SERVICE AGENT BE CONTACTED TO DETERMINE THE REASON FOR OPERATION BEFORE RESETTING.**

### ⚠ WARNING



- Before removing any access panels or servicing the water heater, make sure the electrical supply to the water heater is turned "OFF".
- Failure to do this could result in death, serious bodily injury, or property damage.

- Turn off and unplug the water heater. Do not attempt to reset thermostat with power on.
- Remove the front panel, see "Removing Front Panel" in the Periodic Maintenance section.
- Removing the insulation to expose the reset button.
- Reset the high limit by pushing in the red button.
- Replace the insulation so that it completely covers the thermostat and element.
- Replace the front panel.
- Plug in and turn on the water heater.



# PERIODIC MAINTENANCE

## ANODE ROD INSPECTION

### ⚠ CAUTION

#### Property Damage Hazard

- Avoid water heater damage.
- Inspection and replacement of anode rod required.

The anode rod is used to protect the tank from corrosion. Most hot water tanks are equipped with an anode rod. The submerged rod sacrifices itself to protect the tank. Instead of corroding the tank, water ions attack and eat away the anode rod. This does not affect the water's taste or color. The rod must be maintained to keep the tank in operating condition.

**NOTE:** Artificially softened water is more corrosive because the process substitutes sodium ions for magnesium and calcium ions. The use of a water softener may decrease the life of the water heater tank.

Anode deterioration depends on water conductivity, not necessarily water condition. A corroded or pitted anode rod indicates high water conductivity and should be checked and/or replaced more often than an anode rod can extend the life of your water heater. Inspection should be conducted by a qualified technician, and at a minimum should be checked every three years. The anode rod in this unit is attached to the element flange. For removal instructions, see "ELEMENT CLEANING/REPLACEMENT."

Typical (but not all) signs of a depleted anode rod are as follows:

1. The majority of the rods diameter is less than 3/8"
2. Significant sections of the support wire (approximately 1/3 or more if the anode rod's length) are visible.

If the anode rod shows signs of either or both it should be replaced.

**NOTE:** Whether re-installing or replacing the anode rod, check for any leaks and immediately correct if found.

## TEMPERATURE PRESSURE RELIEF VALVE OPERATION

### ⚠ DANGER



- Burn hazard
- Hot water discharge.
- Keep clear of relief valve discharge outlet.

The temperature-pressure relief valve must be manually operated at least once a year.

When checking the temperature-pressure relief valve operation, make sure that (1) no one is in front of or around the outlet of the temperature-pressure relief valve discharge line, and (2) that the water discharge will not cause any property damage, as the water may be extremely hot, see figure 7.

### TEMPERATURE-PRESSURE RELIEF VALVE

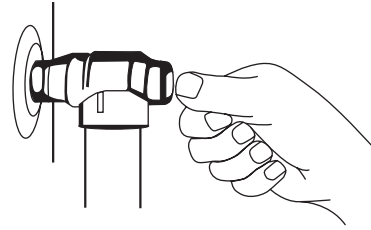

DISCHARGE PIPE

FIGURE 7.

If after manually operating the valve, it fails to completely reset and continues to release water, immediately close the cold water inlet to the water heater, follow the draining instructions, and replace the temperature-pressure relief valve with a new one.

If the temperature-pressure relief valve on the appliance weeps or discharges periodically, this may be due to thermal expansion. You may have a check valve installed in the water line or a water meter with a check valve. Consult your local water supplier or service agency for further information. Do not plug or remove the temperature-pressure relief valve.

## DRAINING

### ⚠ DANGER

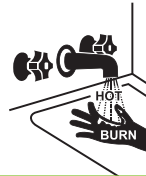

- Burn hazard
- Hot water discharge.
- Keep clear of relief valve discharge outlet.

The water heater should be drained if being shut down during freezing temperatures. Also periodic draining and cleaning of sediment from the tank may be necessary.

1. Turn off and unplug the water heater from the electric outlet.
2. CLOSE the cold water inlet valve to the water heater.
3. OPEN a nearby hot water faucet and leave open to allow for draining.
4. Disconnect water connections. Remove unit from wall. UNIT WILL BE HEAVY. Turn unit upside down and drain unit into a suitable drain or receptacle.

## REMOVING THE FRONT PANEL

1. Turn off and unplug the water heater from the electric outlet and follow "DRAINING INSTRUCTIONS".
2. Remove the temperature knob by pulling straight out.
3. Using a Philips screwdriver, unscrew the bottom screw securing the outer door, see Figure 8.
4. Lift up and remove front panel.



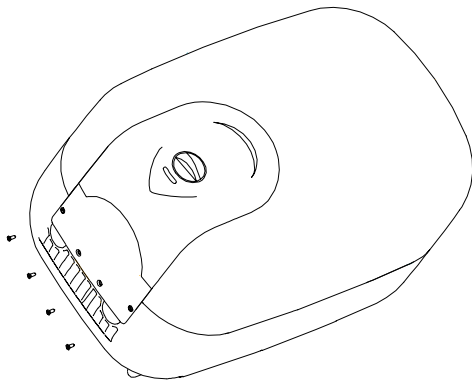

FIGURE 8.

## THERMOSTAT REMOVAL/ REPLACEMENT

### ⚠ WARNING



- Before removing any access panels or servicing the water heater, make sure the electrical supply to the water heater is turned "OFF".
- Failure to do this could result in death, serious bodily injury, or property damage.

### REMOVAL

1. Turn off and unplug the water heater from the electric outlet.
2. Remove the front panel; see the "REMOVING THE FRONT PANEL" section in this manual. Remove the insulation pad.
3. Using a 7mm wrench, loosen the nuts securing the high limit switch to the tank enough to rotate the switch 90° counterclockwise and slide it out from beneath the bracket. It is not necessary to remove the nuts completely.
4. Remove the 3 wires (whit, brown, and green/yellow) from the thermostat at the spade connections, carefully taking note of the original location of each wire.
5. Unscrew the 2 screws securing the thermostat to the front panel and remove thermostat.

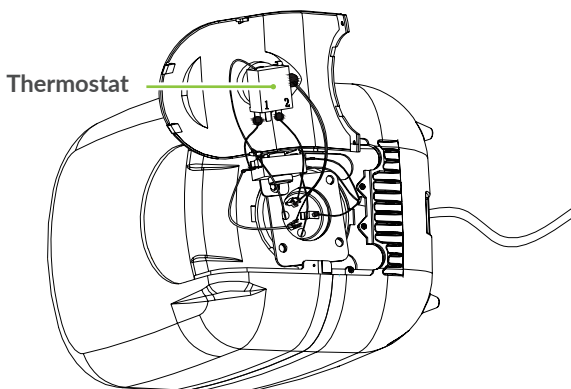

FIGURE 9.

### REPLACEMENT

1. Place the new thermostat against the front panel and secure it with the two screws.
2. Reattach the wires at the spade connections, taking care to place them in their original locations. Be sure to push the connector completely onto the spade terminals.
3. Secure the temperature sensor to the tank by tightening the nuts. Be sure the sensor is firmly in contact with the tank surface.
4. Replace the insulation block and the front panel.

### ⚠ WARNING



- Before removing any access panels or servicing the water heater, make sure the electrical supply to the water heater is turned "OFF".
- Failure to do this could result in death, serious bodily injury, or property damage.

To remove the element from the tank in order to clean or replace it:

1. Turn off and unplug the water heater from the electrical outlet and follow "DRAINING INSTRUCTIONS."
2. Remove the front panel; see the "REMOVING THE FRONT PANEL" section in this manual. Remove the insulation pad.
3. Remove the two screws from the mounting bracket; see Figure 10, being careful not to drop the screws into the unit, as they will be difficult to retrieve. Remove bracket and set screws aside.
4. Remove the two spade connectors from the element.
5. Using a 10mm wrench, remove the four nuts around the element flange. Set nuts and lock washers aside.
6. Lift element up to clear the four mounting bolts, rotate 15 clockwise, and lift out.
7. Discard the old gasket and clean the area around the element opening. Removing any sediment from or around the element opening and inside the tank.
8. If you are cleaning the element you have removed, do so by scraping or soaking in vinegar or a deli ming solution.

**NOTE: Replacement elements must(1) be the same voltage and (2) no greater wattage than listed on the model rating plate affixed to the water heater.**

9. A new gasket must be used in all cases to prevent a possible water leak. Place new element gasket in the element opening over the four element bolts, orienting the gasket bulge facing water side.
10. Insert the curved part of the element, rotate 20 clockwise, and continue to insert the element, being sure that the four bolts fit into the element flange.
11. Replace the four lockwashers and 10mm nuts. Tighten until snug.
12. Place unit back on wall mounting bracket hooks. Reconnect the water inlet and outlet, open the nearest hot water tap and follow filling instructions.

## ⚠ CAUTION

Improper installation and use may result in property damage.

- Fill tank with water before operation.

Never use this water heater unless it is completely full of water. To prevent damage to the tank and heating element, the tank must be filled with water. Water must flow from the hot water faucet before turning "ON" power. The manufacturer will not warranty any elements damaged by failure to follow instructions.

13. Check element for water leaks. If leakage occurs, tighten clockwise. element. If necessary drain tank before repeating Step 7 and 8. Remove element and reposition gasket. Then repeat Step 10 NOTE: The taller spade terminal will be on the right side. through 15.
14. Replace the two spade connectors on element into their original positions.
15. Replace the mounting bracket with the center rise facing outward and the screw hole up, see Figure 10.
16. Replace the insulation and front panel, lining up the three tabs at the top with the slots in the casing.
17. Replace the retaining screw and the temperature knob.
18. Plug heater into electrical outlet.

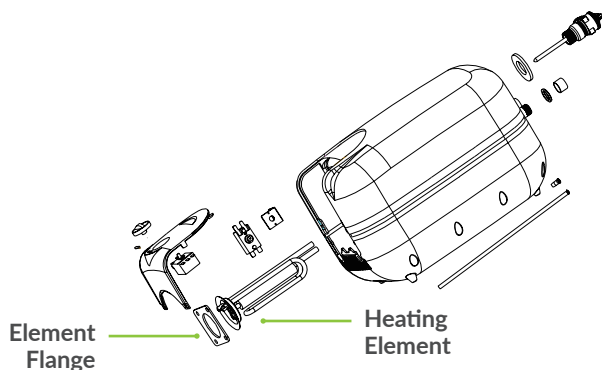

FIGURE 10.

### TO REMOVE AND REPLACE ANODE:

1. Follow steps 1-8 of the Element Cleaning/Replacement section.
2. Using a 7mm wrench, remove the nut securing the anode.
3. Unscrew and remove anode.
4. Screw in the new anode and secure with the retaining nut.
5. Follow instructions for replacing the element in "ELEMENT CLEANING/REPLACEMENT."

### HIGH LIMIT SWITCH REMOVAL AND REPLACEMENT

1. Turn off and unplug the heater from the electrical outlet.
2. Remove the front panel; see the "REMOVING THE FRONT PANEL" section in this manual. Remove the insulation pad. Remove personnel barrier.
3. Remove the four wires connected to the switch, taking care to note the original placement of each wire.
4. Using a 7mm wrench, remove the nuts securing the high limit ° switch to the tank enough to rotate the switch 90 counterclockwise and slide it out from beneath the bracket. It is not necessary to remove the nuts completely.
5. Place the new switch beneath the bracket and rotate it 90

NOTE: The taller spade terminal will be on the right side.

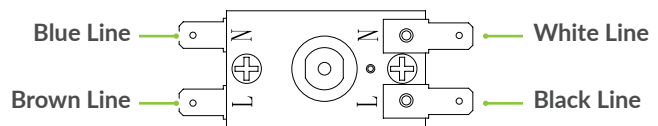

FIGURE 11.

6. Replace and tighten the nuts so the high limit switch is firmly in contact with the tank surface.
7. Replace the four wires, taking care that they are replaced into their original positions and tighten screws.
8. Replace personnel barrier; replace insulation block and the front panel.

### SERVICE

If a condition persists or you are uncertain about the operation of the water heater contact a service agency.

Use this guide to check a "Leaking" water heater. Many suspected "Leakers" are not leaking tanks. Often the source of the water can be found and corrected.

If you are not thoroughly familiar with your water heater and safety practices, contact a qualified installer to check the water heater.

# LEAKAGE CHECKPOINTS

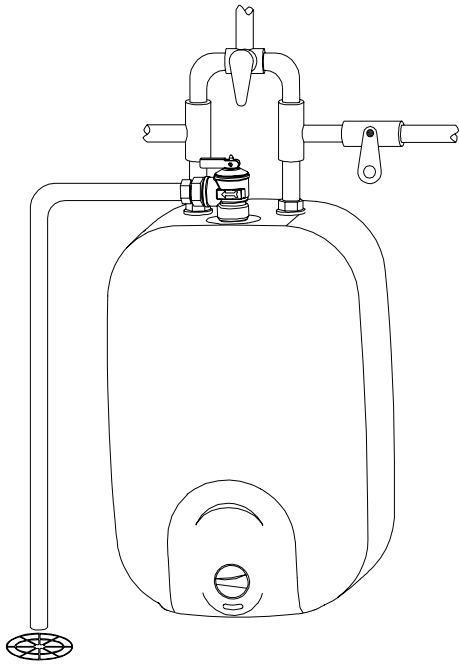

FIGURE 12.

## ⚠ WARNING



Read and understand this instruction manual and safety messages before installing, operating, or servicing this water heater.

Failure to follow these instructions and safety messages could result in death or serious injury.

This manual must remain with water heater.

Read this manual first. Make sure the electrical power supply has been turned "OFF" before checking the tank for leakage.

\*A. Condensation and dripping may be seen on pipes if the water temperature is low in humid weather or pipe connections may be leaking.

B. Small amounts of water from temperature-pressure relief valve may be due to thermal expansion or high water pressure in your area. If the valve is not piped to an open drain the released water could be mistaken for a leaking heater, see "Thermal Expansion" section.

\*C. The temperature-pressure relief valve may be leaking at the tank fitting.

D. Water on the side of the tank may be condensation due to the panel or insulation not being in place.

\*E. Water in the water heater bottom or on the floor may be from condensation, loose connections, or the relief valve. DO NOT replace the water heater until a full inspection of all possible water sources is made and necessary corrective steps taken.

Leakage from other appliances, water lines, or ground seepage should also be checked.

\*To check where threaded portion enters tank, insert cotton swab between jacket opening and fitting. If cotton is wet, follow "Draining" instructions in the "Periodic Maintenance" section and then remove fitting. Put pipe dope or Teflon tape on the threads and replace. Then follow "Filling the Water Heater" instructions in the "Installing the New Water Heater" section.

## ⚠ WARNING



- Before removing any access panels or servicing the water heater, make sure the electrical supply to the water heater is turned "OFF".
- Failure to do this could result in death, serious bodily injury, or property damage.

# TROUBLESHOOTING GUIDELINES

Problem	Possible Cause	Corrective Action
<b>WATER LEAKS</b> (See Leakage Checkpoints in this manual)	Improperly sealed, hot or cold supply connection, relief valve or drain valve.	Tighten threaded connections
	Leakage from other appliances or water lines.	Inspect other appliances near water
<b>NO HOT WATER</b>	No power to heater.	Turn on electrical switch. Check for blown fuses or tripped breaker.
	High Temperature Limit Switch open.	Reset. Check for source of trouble and correct.
	Non-functioning thermostat.	Replace thermostat
<b>INSUFFICIENT HOT WATER</b>	Non-functioning thermostat.	Replace thermostat
	Improper calibration	Replace thermostat
	Thermostat set too low.	Set thermostat to desired temperature.
	Sediment or lime in tank.	Drain. Determine if water treatment is needed.
	Heater too small for job.	Install adequate water heater.
	Wrong piping connections.	Correct piping.
	Leaking faucets.	Repair faucets.
	Wasted hot water.	Review and reduce hot water consumption.
	Long runs of exposed pipe/insulate piping.	Insulate piping.
	Hot water piping on outside wall.	Insulate piping.
<b>HIGH OPERATION COSTS</b>	Improper Calibration.	Replace thermostat.
	Thermostat set too high.	Set thermostat to desired setting.
	Sediment or lime in tank.	Drain. Flush-Provide water treatment if needed
	Heater too small for job.	Install adequate heater.
	Wrong piping connections.	Correct piping.
	Leaking faucets.	Repair faucets.
	Wasted hot water.	Review and reduce hot water consumption.
	Long runs of exposed piping.	Insulate piping.
	Hot water piping in exposed wall.	Insulate piping.
<b>SLOW HOT WATER RECOVERY</b>	Non-functioning element.	Replace element.
<b>DRIP FROM RELIEF VALVE</b>	Excessive water pressure.	Use Pressure Reducing Valve and Pressure Relief Valve
	Closed system.	See "Thermal Expansion" in the For Your Information section
<b>THERMOSTAT DOES NOT SHUUTOFF</b>	Non-functioning element.	Replace thermostat.
	Improper calibration.	Replace thermostat.
<b>WATER ODOR</b>	Sulfides in the water.	See "Operational Conditions" in the For Your Information section.
<b>WATER HEATER SOUNDS</b>	Scale accumulation on elements.	Contact dealer to clean or replace elements.

