

OVERSHELF ASSEMBLY INSTRUCTIONS

600DOS1284, 600DOS1884, 600DOS1296, 600DOS1896

REGENCY
Tables and Sinks

PARTS

A) 1pc



B) 6pcs



C) 1pc



D) 2pcs
L-Brackets



E) 1pc

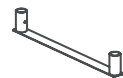

F) 12pcs



- 1** Place the top shelf (A) upside down on a surface that won't scratch it.

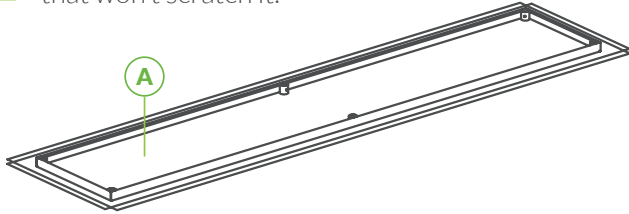

- 2** Secure the six legs (B) into the top shelf gussets using the Allen wrench and set screws (F) provided. You may need to loosen a set screw if one struggles to go in.

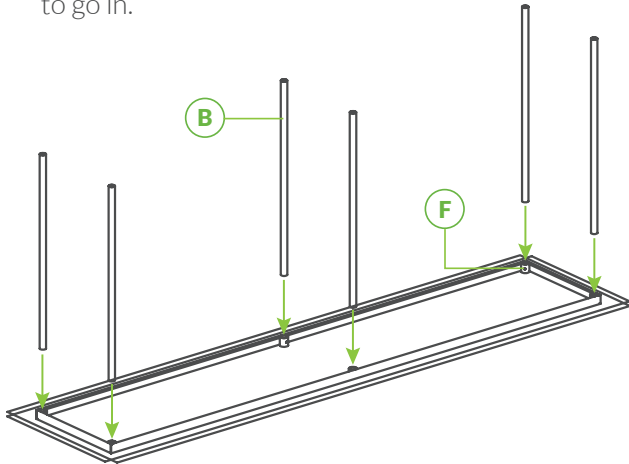

- 3** Slide the midshelf (C) into place and secure it using the set screws.

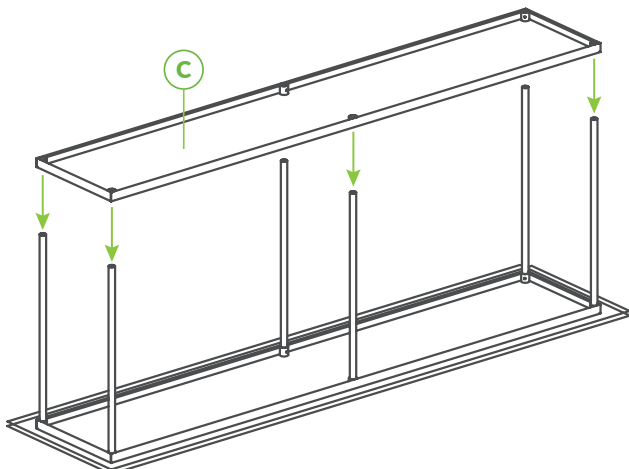

- 4** Secure the two L-brackets (D) and middle bracket (E) to the bottom of the legs with the set screws.

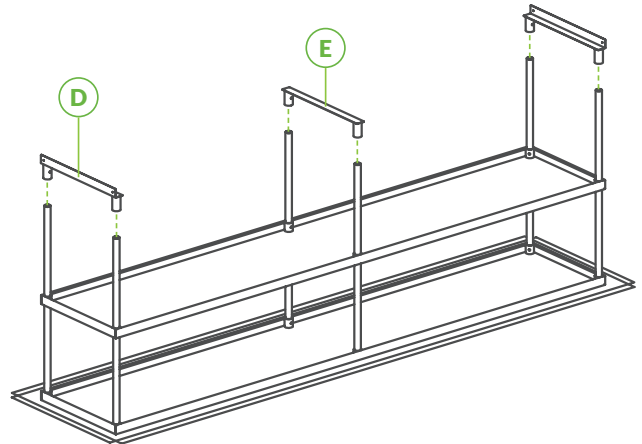

- 5** Align the overshelf to the back of the table to be mounted. Ensure the L-brackets are aligned properly and pre-drill holes through the side of the tabletop for screws. Screw L-brackets into the table (screws not included).

