



User Manual

Door Type Dishwasher



Intertek
9900857

CONFORMS TO UL STD. 921
CERT. TO CSA STD. C22.2 N°168



Intertek
9900857

CONFORMS TO STD.
NSF/ANSI 3-2019



Code 12318949
Revised 10/2023

Model: 541HTDT403; 541HTDT401

Please read and keep these instructions. Indoor use only.







READ FIRST



THIS MANUAL MUST BE RETAINED FOR FUTURE REFERENCE. READ, UNDERSTAND, AND FOLLOW THE INSTRUCTIONS AND WARNINGS CONTAINED IN THIS MANUAL.

WARNING

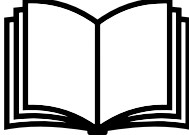
IMPROPER INSTALLATION, ADJUSTMENT, ALTERATION, SERVICE, OR MAINTENANCE CAN CAUSE PROPERTY DAMAGE, INJURY OR DEATH. READ THE INSTALLATION, OPERATION, & MAINTENANCE INSTRUCTIONS THOROUGHLY BEFORE INSTALLING OR SERVICING THIS EQUIPMENT.

				
WARNING	HAZARDOUS VOLTAGE	PLEASE READ INSTRUCTIONS	PROTECTIVE EARTH	EQUIPOTENTIAL BONDING

Model:	Purchased From:
Serial:	Location:
Date Purchased:	Date Installed:
Purchase Order:	For Service, call:

Congratulations on your purchase of Mainstreet Equipment commercial dishwashing equipment! At Mainstreet Equipment, we take pride in the design, innovation, and quality of our products. When used as intended and with proper care and maintenance, you will experience years of reliable operation from your Mainstreet Equipment dishwasher. To ensure optimal performance, we have outlined the following instructions and guidelines in this manual carefully for your review. Mainstreet Equipment declines any responsibility in the event users do not follow the instructions or guidelines stated here.

1. INDEX

1. INDEX	3
2. GENERAL INFORMATION AND WARNINGS	4
3. GENERAL MEASUREMENTS AND CONNECTIONS	5
4. QUICK STARTUP GUIDES	6
5. ELECTRICAL DIAGRAMS	7
6. ELECTRIC DIAGRAMS LEGEND	8
7. PRODUCT DETAILS	9
7.1 Technical specifications	10
8. INSTALLATION INSTRUCTIONS	12
8.1 Removal of packaging	12
8.2 Positioning and leveling	12
8.3 Electrical connection	13
8.4 Water supply connection	14
8.5 Drainage connection	15
8.6 Electric rinse aid dispenser	17
8.7 Detergent dispenser	18
8.8 Recycling	19
9. USE AND MAINTENANCE INSTRUCTIONS	20
9.1 Operation	20
9.1.1 Control panel symbols	20
9.1.2 Switching on the machine	21
9.1.3 Hygiene practices	21
9.1.4 Preparation of the dishes	22
9.1.5 Selecting the wash cycle	23
9.1.6 Stopping the wash cycle and end of wash cycle	23
9.1.7 Drainage of the machine	24
9.1.8 Switching off the machine	25
9.1.9 Cleaning the machine at the end of the day	25
9.2 Cleaning and Maintenance Instructions	25
9.2.1 Routine maintenance	25
9.2.2 Rinse aid and detergent	26
9.2.3 Prolonged non use	26
10. FAULTS AND TROUBLESHOOTING	27

2. GENERAL INFORMATION AND WARNINGS

This manual has been created to help you understand the operation, installation, and maintenance of the machine. It contains all the necessary information and warnings to ensure that the appliance is installed and used correctly, together with information about the characteristics and possibilities offered, so that you may enjoy your machine to the fullest.



BEFORE STARTING THE APPLIANCE, PLEASE READ THE INSTRUCTIONS CONTAINED IN THIS MANUAL CAREFULLY.



**The manual should be kept safely on hand for future reference.
If the machine is sold or transferred, please pass the manual to the new user.**

THIS APPLIANCE IS EXCLUSIVELY FOR PROFESSIONAL USE AND SHOULD ONLY BE USED BY QUALIFIED PERSONNEL.

- The positioning and installation, and all repairs or modifications, should always be carried out by an **AUTHORIZED TECHNICIAN**, in accordance with the applicable local legislation. The manufacturer does not accept liability if the machine is incorrectly installed.
- The installation, incorrect adjustment, inappropriate maintenance, or use of the appliance may cause material damages and injuries.
- The dishwasher should be correctly leveled, and care should be taken to ensure that none of the electric cables, water, or drainage hoses are trapped or kinked.
- **DO NOT** climb on top of the dishwasher or place heavy objects on top of the machine as it has only been designed to bear the weight of the basket of plates to be washed.
- **The dishwasher is designed for washing plates, glasses, and other kitchenware with traces of human food. Any other objects must not be washed in the machine.**
 - If your machine breaks down, please **contact authorized dealer**.
 - Unqualified or unauthorized personnel must **NOT** try to repair the machine.
 - Use of spare parts other than original parts will cancel the guarantee.
 - During all maintenance operations, the dishwasher must be disconnected from the main power supply at the mains power switch, and the water intake tap must be closed.
 - Abrasive or corrosive products, acids, solvents, and chlorine-based detergents must **NOT** be used to clean the appliance, as this may damage the components.
 - Detergents or sanitizers shall not be manually added to the machine.
 - This appliance has been designed for use in ambient temperatures between 41 °F and 104 °F



Failure to comply with these instructions or the incorrect use of the appliance shall relieve the manufacturer of any obligations regarding the guarantee or possible claims.

3. GENERAL MEASUREMENTS AND CONNECTIONS

Door Type Dishwashers (541HTDT403; 541HTDT401)

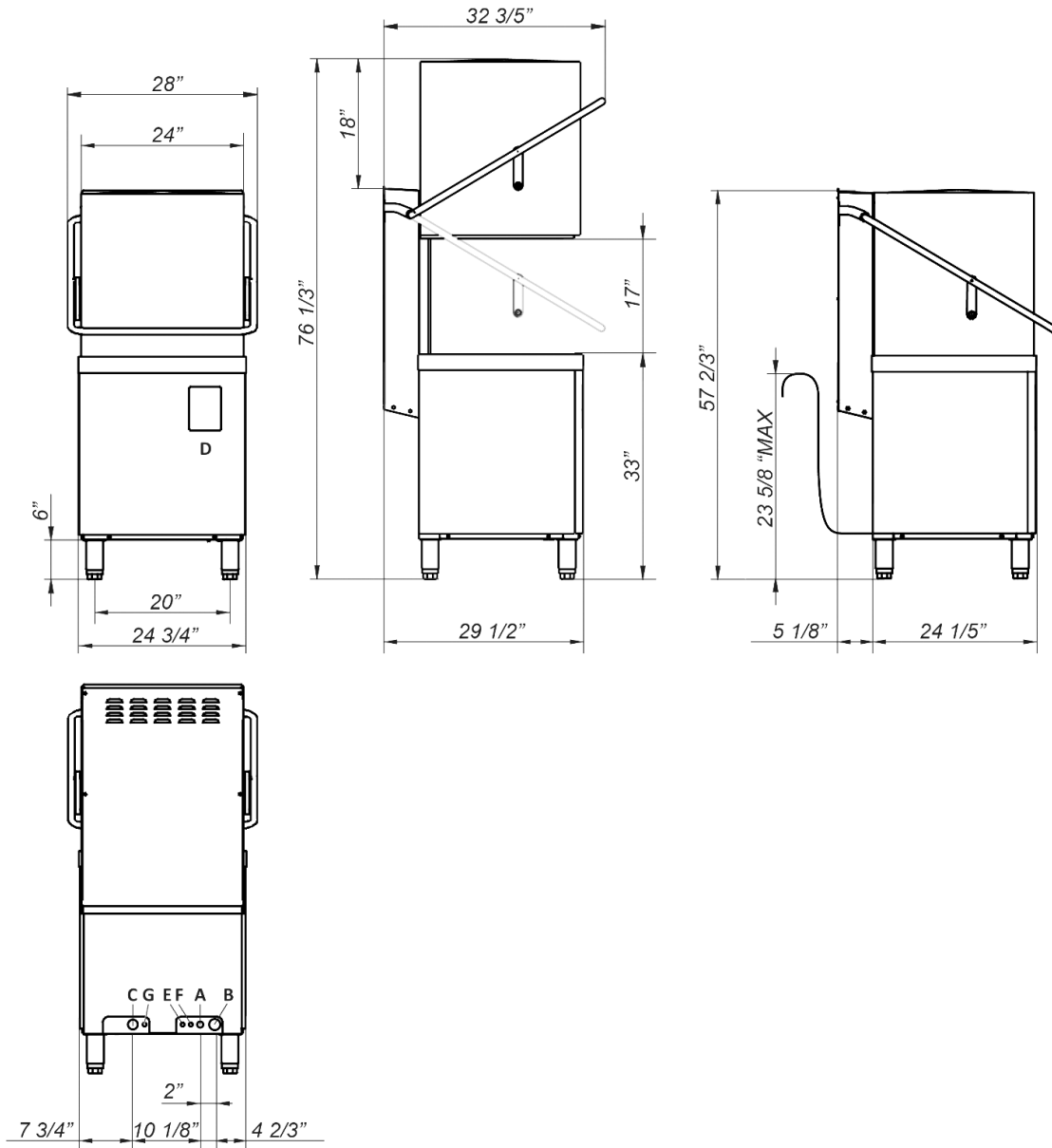





A	B	C	D	E	F	G
Water Inlet	Drain Hose	Power Supply Cable Strain Relief	Connection Strip (Inside)	Rinse Aid Inlet	Detergent Inlet	Equipotential Bond

4. QUICK STARTUP GUIDES

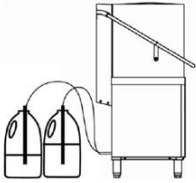
QUICK START GUIDE

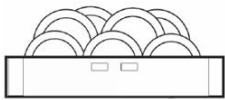

WASH



- 1  Check chemical levels
- 2  Turn on: Hold the on/off button for 3 seconds
- 3  Wait for wash temperature to read between 160-164 °F / 71-73 °C
- 4  Pre-scrap wares thoroughly
Place in rack
- 5  Lift door and load rack into dishwasher
- 6  Close door, press P1, P2 or P3 for 1 second or press and hold P3 for 3 seconds to start wash cycle
- 7

WASH CYCLE IS EXTENDED IF THE FINAL RINSE WATER IS NOT UP TO 180 °F / 82 °C

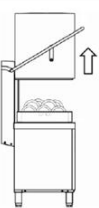
Cycle is complete when cycle light stops blinking

DRAIN

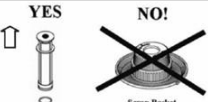
- 1  Lift door, remove rack
- 2  Gravity
Hold on/off button for 3 seconds to turn machine off
- 3  YES NO!
Remove overflow tube
- 4

KEEP DOOR OPEN UNTIL WATER HAS DRAINED. CLEAN INSIDE THE UNIT AND REPLACE COMPONENTS
- 2  YES NO!
Remove overflow tube
- 3  With door open, hold on/off button for 3 seconds to start drain cycle
- 4

KEEP DOOR OPEN UNTIL WATER HAS DRAINED. CLEAN INSIDE THE UNIT AND REPLACE COMPONENTS

5. ELECTRICAL DIAGRAMS

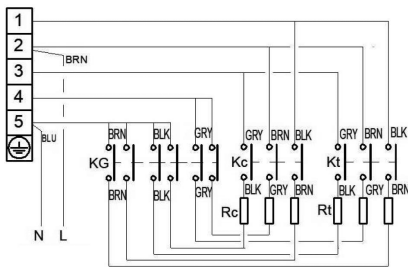
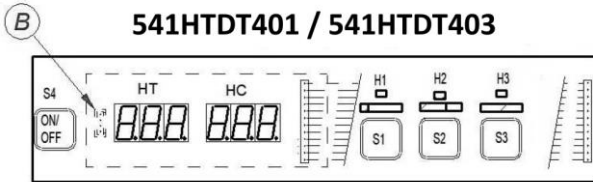

208-240 V 3Ph

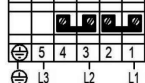

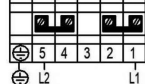

208-240 V 1Ph

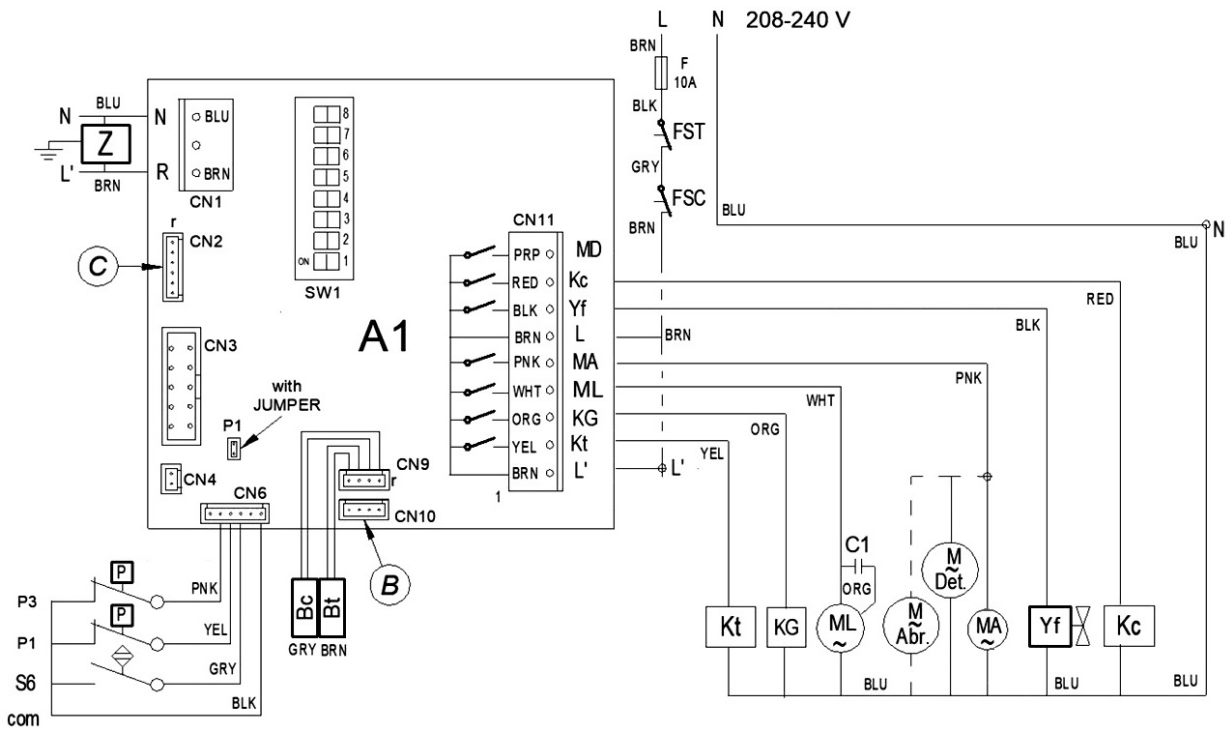
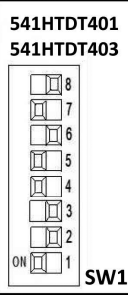

Bridge



6. ELECTRICAL DIAGRAMS LEGEND

	Terminal block bridge	MD	Drain Pump
A1, A2	Electronic Board	MDet	Detergent Dispenser
A1-P1	Electric Bridge / Jumper	ML, ML1, ML2	Wash Pump
Bc	Boiler temperature probe	N	Neutral
Bt	Tank Temperature Probe	P1	Tank Pressure Switch
C1, C2	Capacitor	P2	Tank Safety Pressure Switch
F	Fuse	P3	Boiler Pressure Switch
FSC	Boiler Safety Thermostat	PE / 	Earth Ground
FST	Tank Safety Thermostat	RC	Boiler Heating Element
H1, H2, H3	Cycle Light	RT	Tank Heating Element
H4	Power On Light	S1, S2, S3	Program/Cycle Push button
HC	Boiler temperature Display	S4	ON/OFF Push button
HT	Tank Temperature Display	S6	Door Switch
KC	Boiler Heating Contactor	SW1	DIP-SWITCH
KG	Main Relay	TRF	Transformer
KT	Tank Heating Contactor	Y	Tank Filling Solenoid valve
L, L1, L2, L3	Power Supply Phases	Yf	Boiler Filling Solenoid valve
MAbr	Rinse Aid Dispenser	Z	EMC Filter
MA	Rinse Pump		

	COLOR
BLK, bk, n	Black
BLU, bl, a	Blue
BRN, bn, m	Brown
GRN, gn, ve	Green
GRY, gy, g	Grey
ORG, or, na	Orange



	COLOR
PNK, pk, rs	Pink
PRP, pr, vi	Purple
RED, rd, r	Red
WHT, wh, b	White
YEL, yw, am	Yellow
YW/GN, am/ve	Yellow / green

7. PRODUCT DETAILS

As it is an industrial product, the unit is characterized for having a high dishwashing capacity. The characteristics of the product are listed below to help you understand your machine better.

All the appliances have a nameplate which identifies the appliance and indicates its technical characteristics. Under no circumstances should the data plate be removed from the unit. The data plate is essential to identify the particular features of your machine and is of great benefit to installers, operators, and maintenance personnel. It is recommended that, in the event the data plate is removed, you copy down the essential information in this manual for reference before installation.

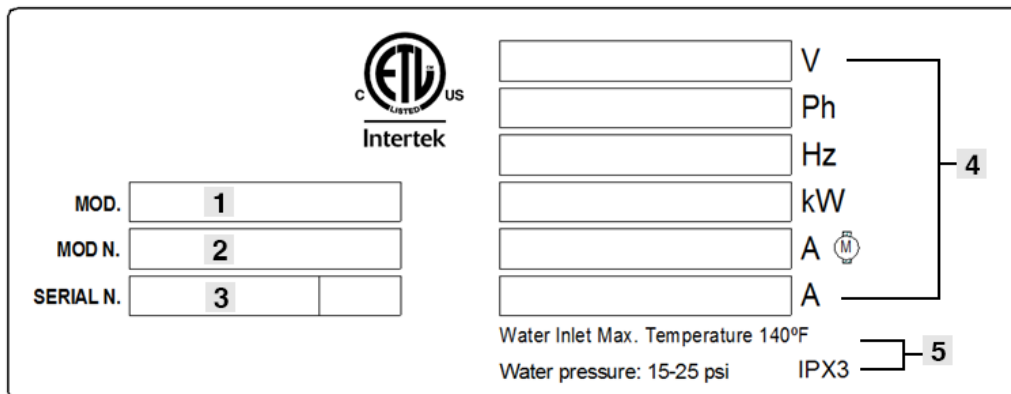
DATA PLATE

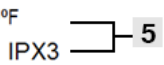
				
MOD.	1		V	
MOD N.	2		Ph	
SERIAL N.	3		Hz	
			kW	
			A 	
			A	
		Water Inlet Max. Temperature 140°F		
		Water pressure: 15-25 psi		

- 1: APPLIANCE MODEL NAME
- 2: APPLIANCE REFERENCE
- 3: SERIAL NUMBER + MANUFACTURE DATE
- 4: ELECTRICAL SPECIFICATIONS
- 5: WATER INLET SPECIFICATIONS

These details should be quoted when the technical service is called.

7.1 Technical Specifications

MODEL	RACKS PER HOUR	WASH TANK (Gal)	GALLONS PER CYCLE	WATER INLET MAX TEMP.	WATER INLET PRESSURE
Door Type - 541HTDT403; 541HTDT401	40	8.7	0.53	140° F	At Water Inlet 15 - 58 psi

MODEL	WASH PUMP MOTOR	HEATING ELEMENTS		OPERATING CYCLE TIME (s)			
		WASH TANK (kW)	BOILER (kW)	WASH	DWELL	RINSE	TOTAL
Door Type - 541HTDT403	1 hp	4.9	9.8	74/104/164/584	5	11	90/120/180/600
Door Type - 541HTDT401	1 hp	3.25	6.5	74/104/164/584	5	11	90/120/180/600

MODEL	WIDTH	DEPTH	HEIGHT	MAX CLEARANCE FOR DISHWARE	RACK
Door Type - 541HTDT403; 541HTDT401	24 3/4"	29 1/2"	57 2/3"	17"	20" x 20"

MODEL	CONNECTION TYPE	VOLTAGE (V)	TOTAL LOAD (A)	TOTAL POWER (kW)	PUMP LOAD (A)	PUMP POWER (kW)	TANK POWER (kW)	BOILER POWER (kW)
Door Type - 541HTDT403	208-240V 60Hz 3Ph	208V	33.52	11.64	2.87	0.60	3.68	7.36
		220V	35.45	13.02	3.04	0.67	4.12	8.23
		240V	38.67	15.49	3.31	0.79	4.90	9.80
Door Type - 541HTDT401	208-240V 60Hz 1Ph	208V	38.26	7.96	2.87	0.60	2.45	4.91
		220V	40.47	8.90	3.04	0.67	2.74	5.49
		240V	44.14	10.59	3.31	0.79	3.27	6.53

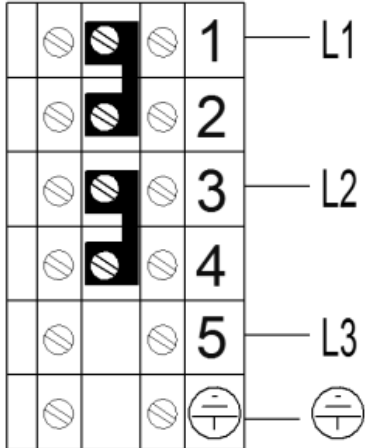
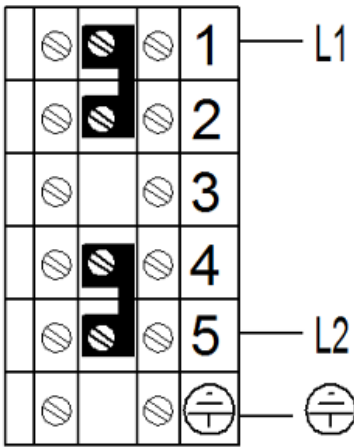
DOOR TYPE DISHWASHERS	
541HTDT403	541HTDT401
	
208-240V, 60HZ 3PH	208-240V, 60HZ 1PH
AWG 6 MCA 45A / MOP 50A	AWG 6 MCA 51A / MOP 60A



8. INSTALLATION INSTRUCTIONS



The dishwasher shall be installed in accordance with local codes, or in the absence of local codes, installed in accordance with the applicable requirements in the National Electrical Code, NFPA 70, Canadian Electrical Code (CEC), Part 1, CSA C22.1, and Standard for Ventilation Control and Fire Protection of Commercial Cooking Operations, NFPA 96.



The positioning and installation, and all repairs or modifications, should always be carried out by an **AUTHORIZED TECHNICIAN**, in accordance with the applicable legislation of the country.

The installation, incorrect adjustment, inappropriate maintenance, or use of the appliance may cause material damages and injuries.

8.1 Removal of packaging

Remove packaging from the machine and check for damage during transportation. If any damage is observed, immediately notify the supplier and the transport company. In the event of doubt, do not use the machine until the problem has been assessed.



Packaging (plastic, expanded polyurethane, staples, etc...) must not be left in the reach of children. They are a potential hazard.

The machine should be moved using a fork-lift truck or similar to avoid damage to the structure. Transport the machine to the installation location and then remove packaging. All the packaging can be recycled. Dispose of packaging correctly.

8.2 Positioning and leveling

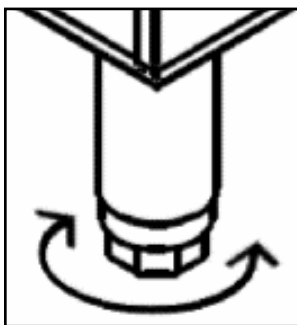

This appliance has adjustable feet. This is done by turning the leveling stands to the desired height. For optimum operation, it is essential that the machine is correctly leveled. The flooring on which the machine is to be installed must be able to bear the full weight of the machine.



Inspect final location of the machine prior to installation to prevent damage during use.

8.3 Electrical connection

An AUTHORIZED TECHNICIAN should always carry out the appliance's electrical connection.



The dishwasher shall be installed in accordance with local codes, or in the absence of local codes, installed in accordance with the applicable requirements in the National Electrical Code, NFPA 70, Canadian Electrical Code (CEC), Part 1, CSA C22.1, and Standard for Ventilation Control and Fire Protection of Commercial Cooking Operations, NFPA 96."



THIS APPLIANCE, WHEN INSTALLED, MUST BE ELECTRICALLY GROUNDED

The manufacturer cannot accept any responsibility for damage caused from a failure to observe grounding instructions.

- Refer to the wiring diagram, the machine data plate, and technical specifications for service size requirements.
- Check that the mains voltage corresponds to that indicated on the nameplate.
- The power-supply cord shall be Type S, SE, SO, SOO, ST, STO, or STOO (with or without W at the end).
- The power supply cord wire size must be suitable for the rated current of the machine (amperage load). Use copper conductors only.



- The appliance must be grounded using the ground connection of the terminal block of the appliance.
- An all phase Circuit Breaker must be installed near to the appliance between the power supply and the appliance in accordance to required consumption guidelines. Switch the circuit breaker to "OFF" when servicing the appliance. It is recommended that it has lockout-tagout capabilities. The manufacturer will not be held liable for damage originated by failure to observe this requirement.
- A suitable safety switch / Residual current device must be installed near the appliance between the power supply and the appliance. The manufacturer will not be held liable for damage originated by failure to observe this requirement.
- If any faults are observed during the installation, the supplier should be notified immediately.

When a number of appliances are installed in line, they should all be ground bonded at the point provided for that purpose.

To access the connection strip when a permanent connection needs to be made, release the cover of the machine's front (see Section 2 - General Measurements and Connections). The power cable is connected to the connection strip. It is also possible to change the machine configuration here.



The manufacturer will not be held liable for any personal or material damage to the machine resulting from incorrect installation or failure to comply with the manufacturer's specifications.

It is the personal responsibility and obligation of the customer to contact a qualified electrician to assure that the electrical installation is adequate.

8.4 Water supply connection

The new hoses supplied with the appliance should be used (do not reuse old hoses).
Before connecting the machine to the water supply, the water quality should be tested.
Recommended water quality:

pH: 6.5 to 7.5	Alkalinity: Less than 50 ppm (mg/L)
Free Chlorine: Less than 0.2 ppm (mg/L)	Total Dissolved Solids (TDS): Less than 60 ppm
Chlorides: Less than 30 ppm (mg/L)	Sulfates: Less than 40 ppm
Hardness: Less than 3 gpg (52 ppm)	Iron: Less than 0.1 ppm
Conductivity: 400 to 1,000 μ S/cm	Copper: Less than 0.05 ppm
Silica: Less than 12 ppm (mg/L)	Manganese: Less than 0.05 ppm

Water installation is carried out as shown in **Fig. 1**:

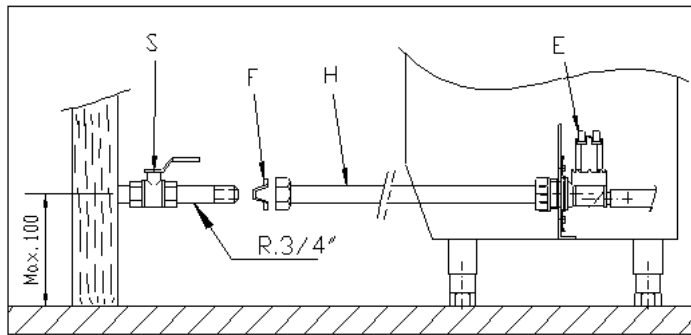

S → SHUT-OFF COCK
F → FILTER
H → WATER HOSE
E → WATER VALVE

Fig. 1. Direct connection of water input hose.

Use 3/4" copper tubing inlet line.

It is necessary to remove all foreign debris from the water line that may potentially get trapped in the valves or cause an obstruction prior to connecting to the machine.

Use only the supplied hoses (3/4" Female hose connector) at the water connections. Failure to do so may result in damage to the solenoid valve threads and leaking. Tighten by hand. Connect the bent side of the hose to the machine. Adaptor supplied for 3/4" female garden hose connection.

FOR HARD WATER SUPPLIES WITH A HARDNESS OF OVER 3 gpg OR 5°fH AND PH BEYOND THE RANGE OF 6.5 – 7.5, A WATER CONDITIONER/DESCALER MUST BE INSTALLED.

Webstaurantstore.com offers a scale prevention system (Item #490047300332).

In addition to water quality, the pressure of the mains water supply must be considered. This is important to ensure the machine operates correctly.

Door Type Dishwashers (541HTDT403; 541HTDT401):

Required water dynamic pressure measured at water inlet between 20-58 psi.

CAUTION: Do not confuse static pressure with flow pressure. Static pressure is the line pressure in a “no flow” condition (all valves and services are closed). Flow pressure is the pressure in the fill line when the solenoid valve is opened during the filling or cycle.

In areas where the pressure fluctuates or it is higher than the recommended pressure, a water pressure regulator shall be installed between the shut-off cock and the water hose (**Fig. 1.**).

If the water pressure is less than required, installation of a water pump is required.

The hot water heater should be set to deliver 140 °F (not lower than 122 °F) water temperature to the dishwasher for best results.

Slowly turn on the water supply to the machine after the incoming fill line and the drain line have been installed. Check for any leaks and repair as required. All leaks must be repaired prior to placing the machine in operation.

The following requirements are necessary for the correct water piping installation of the machine.

- The water piping circuit must be fitted with a valve to shut off the water supply.
- Check that the mains pressure is within the range indicated.
- To optimize the work of the machine, the water temperature at the machine intake should be within the following range: 122 °F (50 °C) < Hot water Temp < 140 °F (60 °C)
- If using hot water, the water temperature must not exceed 60 °C / 140 °F.
- All the machines should have a 3/4” screw-on connection.

8.5 Drainage connection

Attach the drain hose as shown in **Fig. 2** (on next page). The drainage pipe must always be fitted on a siphon to prevent the return of odors.

All piping from the machine to the drain must be a minimum 1-1/2” I.P.S. There should also be an air gap between the machine drain line and the drain. For natural overflow efficiency, use floor drain.

The water draining from the machine must flow freely and therefore the drainage pipe should be lower than the drainage outlet (**Fig. 2**).

If the drainage pipe is not lower, a drainage pump will be required. This must not be mounted at a height of more than **28 5/8”** for door type dishwashers (**Fig. 3**). In this case, the pump may be requested at the time of purchase or subsequently.

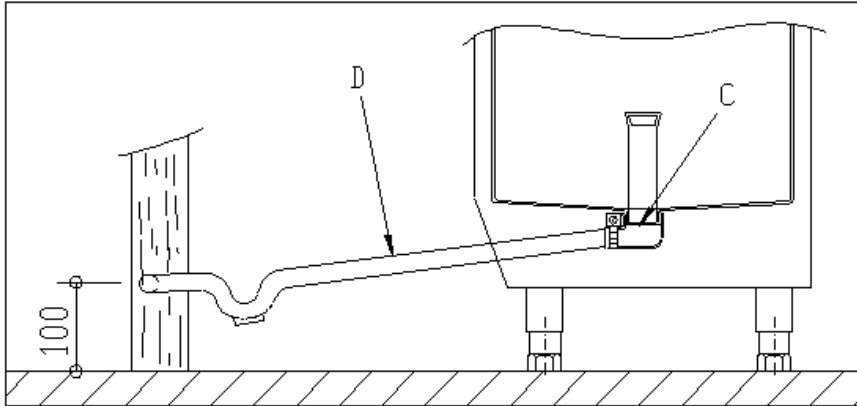
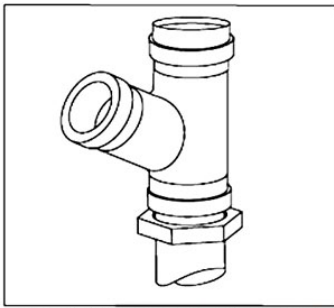
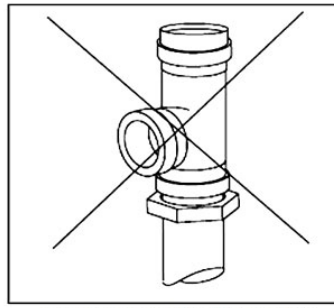

Fig. 2. Drainage installation

D: Drain hose
C: Drain collector



The dishwasher flexible drain hose must be connected to a WYE fitting.



Do not connect the dishwasher flexible drain hose to a TEE fitting.

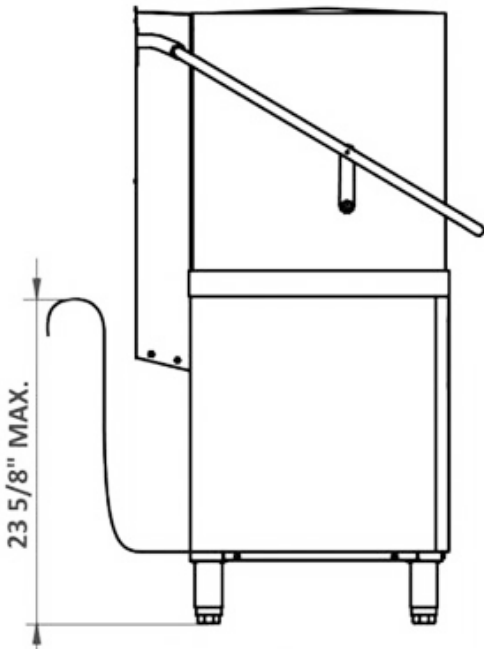

Fig. 3. Installation of drainage at a height using drainage pump.



THE DRAINAGE PUMP MUST ONLY BE INSTALLED BY PERSONNEL AUTHORIZED BY THE MANUFACTURER, AND THE MANUFACTURER DOES NOT ACCEPT LIABILITY IN THE EVENT OF INCORRECT INSTALLATION.

8.6 Electric rinse aid dispenser (door type)

Installation: Take the tube located in the back of your machine marked "Rinse Aid" and place inside rinse container.

Tubes are transparent to provide a visible means to check that chemicals are being dispensed.

Operation: This dispenser absorbs the rinse aid when the rinse pump is switched on. That is, when the machine is filling and when the machine is running the rinse cycle.

Adjustment: The dispenser should be adjusted when the machine is installed to ensure that the wash is optimized from the start. The setting should be adjusted according to the type of rinse aid and the water hardness.

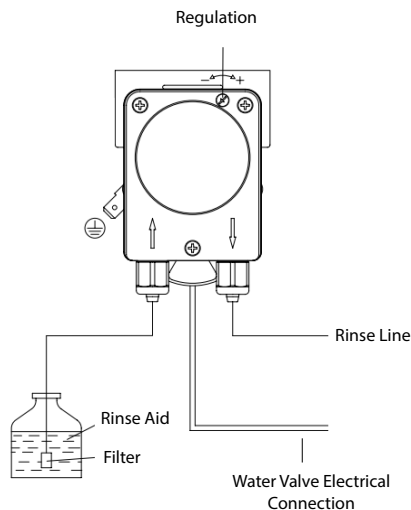

In order to maintain dishwasher at optimum conditions, it is requested to remove lime and corrosion deposits on a frequent basis. A de-liming solution should be available from your chemical supplier. Read and follow all instructions on the label of the de-liming solution. Operations:

- Fill the machine. Add the correct amount of de-liming solutions as recommended by the de-liming solution manufacturer. The water capacity of the tank can be verified on the specification sheet of this manual.
- Remove detergent and rinsing tubes from containers so no chemicals go to the machine.
- Run the machine for the recommended period of time, as many cycles as needed.
- Turn off the machine and open the door.
- When clean, drain and refill the machine.
- Run machine for 3-4 cycles to remove de-liming solution.
- Drain the machine.

If desired, you can control the amount of Chemical being dispensed by opening the bottom front panel of the machine. Locate the detergent dispenser and regulate according to the flow. For the Rinse, turn the button counterclockwise to get more rinse aide and clockwise for less. Verify all connections to the dispenser are hand tightened to prevent any leaks.

Control and maintain the level of detergent and rinse aid of the tanks. Keep chemical tubing and filters submerged.



It is recommended that the rinse aid product and the dispenser setting are defined by a technician specialized in the use of chemical products in order to ensure a more efficient wash.

8.7 Detergent dispenser

This machine must be operated with an automatic detergent feeder including a visual means to verify that detergent is delivered or a visual or audible alarm to signal if detergent is not available for delivery to the respective washing system. Please see instructions for electrical and plumbing connections located in this manual and in the feeder equipment manual.

The detergent dispenser ensures that the correct measure of detergent is supplied to the machine.

Use ONLY Commercial Grade, High Temperature, Low Suds Liquid Detergent. Mainstreet Equipment doesn't recommend any specific brand name of chemicals. Contact your local chemical distributor for questions concerning your chemical needs.

Installation: the detergent dispenser input is in the wash tank front part, above the maximum water level.

Take the tube located in the back of your machine marked "Detergent" and place inside detergent container.

Tubes are transparent to provide a visible means to check that chemicals are being dispensed.

Operation: the detergent dispenser is activated when the machine is taking water, whether it is in rinse cycle or whether it is filling.

Settings: the quantity of detergent used should be adjusted on installation to ensure that the wash is optimized from the start.

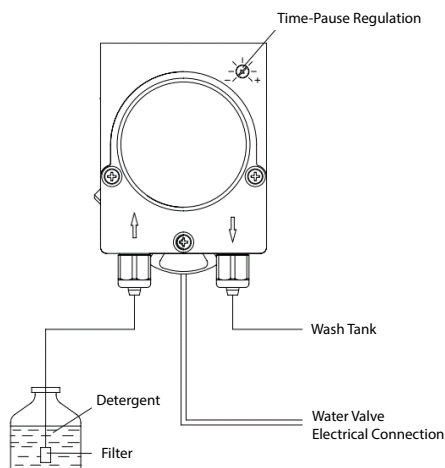



It is recommended that the detergent and the dispenser setting are defined by a technician specialized in the use of chemical products in order to ensure a more efficient wash.



If you require the installation of a NON-MAINSTREET EQUIPMENT Detergent and/or Rinse pump, a form **MUST** be filled out prior to installation by your installer. Failure to do so will void your Warranty. This form can be located inside your dishwasher. If lost, please contact Mainstreet Equipment to get a copy.



The detergent pump and rinse dispensing pump will only work during the process of fill and rinse.

8.8 Recycling

The product packaging consists of:



- A wooden pallet.
- Cardboard.
- A polypropylene band.
- Expanded polyethylene.

All the packaging used around the machine can be recycled. The correct disposal of these products will help to protect the environment. For further information regarding the recycling of these products, please refer to your local recycling authority.

9. USE AND MAINTENANCE INSTRUCTIONS



BEFORE STARTING THE APPLIANCE, PLEASE READ THE INSTRUCTIONS CONTAINED IN THIS MANUAL CAREFULLY.



THE APPLIANCE IS EXCLUSIVELY FOR PROFESSIONAL USE AND SHOULD ONLY BE USED BY QUALIFIED PERSONNEL.

9.1 Operation

The steps required to optimize the operation of your dishwasher are shown below, with all the available options.

9.1.1 Control panel symbols

541HTDT403 / 541HTDT401 (Door Type Dishwasher)

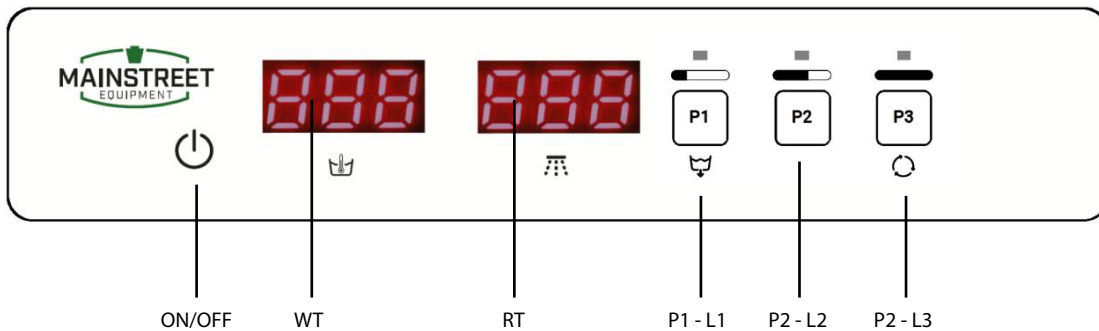

ON/OFF	ON/OFF Button
P1	Wash Cycle 1 / Drainage Button
P2	Wash Cycle 2 Button
P3	Wash Cycle 3 Button Wash Cycle 4 Button (Long pressing 3 seconds)
WT	Wash Tub thermometer
RT	Rinse boiler thermometer
L1 / L2 / L3	Blinking: Cycle pilot light Steady: Wash tub over 150°F

9.1.2 Switching on the machine

Before switching on the machine, check the following:

- The mains switch must be on.
- The water stop cock must be open.
- There must be water in the mains network.
- The corresponding filters must be in place.
- The overflow should be mounted in place.

To switch on the machine just press the ON-OFF button once for 2 seconds.

9.1.2.1 Filling and heating

In the door type models, the filling is thermostatic. This means that when the water boiler is full, the boiler heats the water and then the tank is filled. This process is repeated each time the boiler is emptied during the filling cycle. This filling system is more efficient and helps reduce the filling time.

Once the wash tub is full, the boiler and the tub start to heat up. Although it is possible to start the wash process, this is not recommended as the water inside the machine is not yet at the ideal temperature. When the machine has reached the ideal temperature for washing the dishes properly, a light comes on, advising the user that the machine is ready. The required temperature of the machine is over 180°F in the rinse boiler and over 158°F in the wash tub. It is recommended that the water in the dishwasher is changed every 40/50 washes or twice a day.



The door must be closed for the machine to start filling. For safety reasons, if the door is open, the machine will not fill.

The machine you have purchased has a safety thermostat in the boiler and another for the tub, so that in the event of the breakdown of any of the main thermostats, the safety thermostats switch off the corresponding heating.



During the first heating of the day, the boiler may reach a higher temperature than that mentioned above due to heating inertia. This is normal. If pressurized steam is observed coming out of the rinse arm nozzles, while the boiler is heating, the technical service should be notified.

9.1.3 Hygiene practices

- Operators must strictly observe all hygiene requirements when handling clean dishes and cutlery.
- Do not touch clean dishes with dirty or greasy hands. Handle the dishes/cutlery with gloves or clean hands to prevent contamination. Be careful as the dishes will be hot.
- Use clean sterilized cloths to thoroughly dry the dishes. Do not dry the plates with kitchen towels or cloths that are not sterile.

- Wait until the machine reaches the correct wash temperature to ensure a thorough disinfection and wash. To obtain optimum results, wash the dishes when the machine is ready.
- Drain the wash tub and rinse the filters at least twice a day or every 40-50 wash cycles.
- Make sure that the quantities of detergent and rinse aid dispensed are correct (as recommended by supplier). At the start of the work day, check that the quantity of product in the reservoirs is enough for the daily requirement.
- The dishwasher should be kept perfectly clean and maintained.

9.1.4 Preparation of the dishes

Before washing the dishes, the preparatory steps below should be followed:

- Remove the largest pieces of waste from the dishes before placing them in the baskets to avoid blocking the filters, nozzles, and tubes.
- Wash glassware first.
- Put the plates in the rack basket.
- Place the glasses upside down.
- Place the cutlery in the cutlery baskets with the handles downwards. The different pieces of cutlery can be mixed.
- Place the cutlery baskets in the lower baskets.

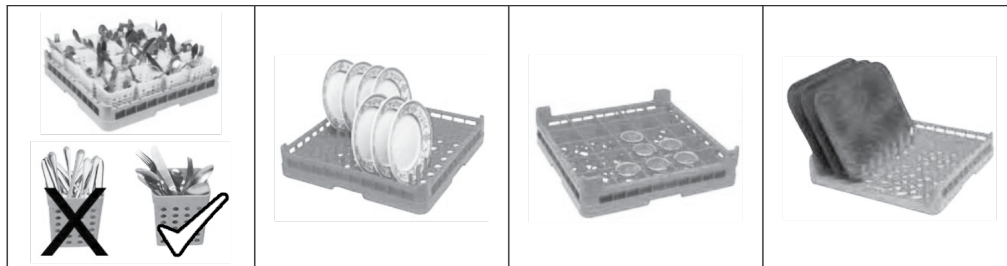

9.1.5 Selecting the wash cycle

Before starting the wash cycle, place the corresponding basket containing the dishes in the machine and close the door.

Before starting the wash cycle, the machine should have the ideal temperature for washing the dishes properly, indicated by the temperature on thermometers, advising the user that the machine is ready. The required temperature of the machine is over 180°F (see thermo-stop chapter) in the rinse boiler and over 158°F in the wash tub.

In the door type dishwashers, the last used (or default at start) wash cycle starts automatically when the door is closed. The cycle can be selected with the door open. Also, a wash cycle button can be pressed (P1/P2/P3/P3-Long press 3s) with the door closed in order to start the wash cycle.

The wash cycle selected by default is P2 in machines with more than one wash cycle button. Each wash cycle corresponds to a wash time that should be selected according to the user requirements.

When the wash cycle starts, the selected program led will switch on blinking.



The door must be closed for the machine to start the wash cycle. For safety reasons, if the door is open, the wash cycle will not start.



If you start your dishwasher prior to your boiler reaching a minimum of 180°F (83°C), YOU WILL HAVE AN EXTENDED WASH CYCLE!

Wash cycle times:

Model	P1	P2	P3	P3 (3s Extended)
Door Type - 541HTDT403	90s	120s	180s	600s
Door Type - 541HTDT401	90s	120s	180s	600s

9.1.5.1 Thermo-stop

The thermo-stop is designed to ensure a constant rinse at the maximum temperature. This means that the machine continues washing until the boiler reaches the ideal temperature. Then the rinse cycle starts.



If the mains water temperature is less than 50°C / 122°F, the wash capacity may be reduced.

9.1.6 Stopping the wash cycle and end of wash cycle

The wash cycle can be stopped or paused in the following ways:

- By pressing the active cycle button → the cycle stops completely.
- By opening the door → Cycle pauses. When the door is closed, the cycle continues.
- By switching off the machine → the cycle stops completely.

At the end of the wash cycle, remove the basket and leave the dishes to dry naturally. Remove the dishes from the basket with clean hands, taking care not to burn yourself as the dishes are extremely hot.

9.1.7 Drainage of the machine

The dishwashers have two types of drainage; gravity drainage or using a drainage pump, which is optional.

9.1.7.1 Drainage by gravity

To drain the machine in this way, first switch off the machine, then just remove the overflow tube from the machine and it will drain naturally. For safety reasons, this drainage method should only be used with the machine switched off.

- Switch off the machine. Press ON/OFF button for 2 seconds to turn unit OFF.
- Open the door and remove the filter tray. (**Fig. 4**)
- Remove the overflow tube. (**Fig. 5**)
- Wait until the tub is empty. Clean any dirt that could be on the bottom of the tub.
- Take out scrap basket for cleaning by twisting to the left. (**Fig. 6**)
- Replace scrap basket. Lock into position by twisting to the right and replace overflow tube with O-ring.
- Replace filter tray back into position (**Fig. 4**).
- Wipe clean and dry the machine if the day is completed. Leave door open until the next day's operations or to one of the time settings to begin using the machine again.
- To avoid the risk of damage from oxidization or corrosion from chemicals, keep all steel surfaces clean.

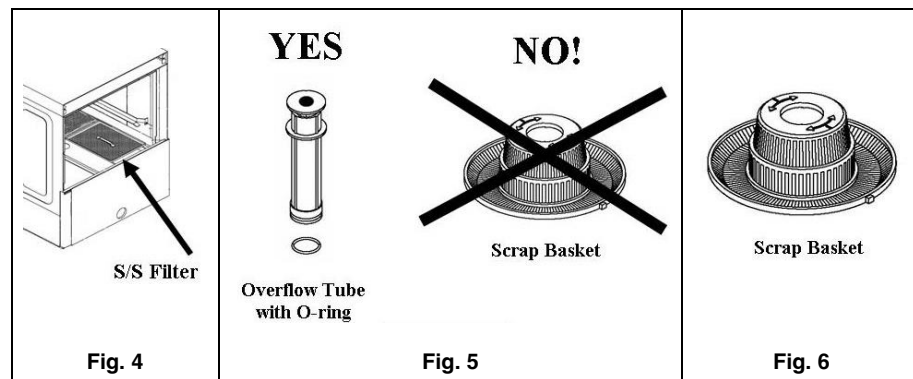

9.1.7.2 Drainage using the drainage pump (Optional)

The drainage using the drainage pump option is only available on request. To drain the machine using this method, proceed as follows:

- Open the door and remove the filter tray. (**Fig. 4**)
- Remove the overflow tube. (**Fig. 5**)
- With the door open, press the button P1 for 3 seconds. L1 will blink during operation.
- Wait until the led L1 turns off. At the end of the drain cycle, the machine will be automatically switched off.
- Clean any dirt that could be on the bottom of the tub.
- Take out scrap basket for cleaning by twisting to the left. (**Fig. 6**)
- Replace scrap basket. Lock into position by twisting to the right and replace overflow tube with O-ring.
- Replace filter tray back into position (**Fig. 4**).
- Wipe clean and dry the machine if the day is completed. Leave door open until the next day's operations or to one of the time settings to begin using the machine again.
- To avoid the risk of damage from oxidization or corrosion from chemicals, keep all steel surfaces clean.



To drain the machine with the drainage pump, the hose must be at a height of 23 5/8" maximum in door type dishwasher.

9.1.8 Switching off the machine

To switch off the machine, just press the ON/OFF button once for 2 seconds.

The machine should not be switched off during the wash process as this will stop the tableware inside the machine from being cleaned properly.

9.1.9 Cleaning the machine at the end of the day

At the end of the day, the filters, rotating wash arms, rinse arms, and other accessories must be cleaned. This is necessary to prolong the service life of the machine.

To ensure the efficient washing of the dishes, the dishwasher must be perfectly clean and disinfected.

9.2 Cleaning and Maintenance Instructions

9.2.1 Routine maintenance

Every day at the end of the day, the filters, rotating wash arms, rinse arms, and other accessories must be cleaned.

To ensure the efficient washing of the dishes, the dishwasher must be perfectly clean and disinfected.

Always clean the machine correctly to prolong the service life of the machine.

- Remove any waste from the machine at the end of each day.
- Do not use abrasive, corrosive, or acid products, chlorine-based detergents, solvents, or petrol derivatives to clean the machine.
- Do not use pressurized water to clean the machine.
- Do not spray off the machine and the immediate vicinity (walls, floors) with a water hose, steam cleaner, or pressure washer.
- In order to prevent water from entering into the machine uncontrollably, make sure that the machine's base is not flooded when cleaning the floor.
- Only wash tableware, glassware, or kitchenware that has been used for human food.
- Check that the rotating wash arms rotate correctly every day.
- Check the rinse aid and detergent levels at the start of each day.
- If the power cable is damaged, it must be replaced by the manufacturer, after-sales service, or authorized technical personnel in order to prevent risks.

9.2.2 Rinse aid and detergent

If you change the rinse aid or detergent, the settings should be adjusted accordingly. This adjustment must be carried out by qualified personnel. Only use detergents suitable for industrial dishwashers. Do not use foam-producing detergents. Detergents designed for domestic use should not be used under any circumstances.



When handling chemical substances, the safety instructions must be observed. Use suitable protective clothing, gloves, and safety goggles when handling chemical substances. Do not mix different detergents.

9.2.3 Prolonged non use

If the machine is kept out of service for a long period of time (holidays, temporary closure...), please observe the following:

- Drain the machine completely, including the boiler.
- Clean the machine thoroughly and leave the door of the machine open.
- Close the water intake valve.
- Switch off the mains power supply.
- If there is a risk of frosts, ask your technical service to protect the machine against frosts.

10. FAULTS AND TROUBLESHOOTING

The steps to be followed in the event of a fault or operating error are described below. The possible causes and possible solutions are listed in the following table. In the event of doubt, or if you are unable to resolve the problem, please contact the technical service.



DO NOT HANDLE ELECTRICAL COMPONENTS, AS THERE IS A RISK OF DEATH AS THE COMPONENTS ARE LIVE.

FAULT	POSSIBLE CAUSE	SOLUTION
The machine does not turn on.	There is no power supply.	Check whether the magneto-thermal circuit breaker has been triggered.
	The fuses have blown.	Call the technical service to analyze the reason why.
	Main switch open.	Close switch.
The machine does not fill with water.	Water entrance valve closed.	Open the water valve.
	Rinse nozzles blocked.	Clean nozzles and check arms for build-up of lime.
	Solenoid valve filter blocked.	Call the technical service to clean the filter.
	Rinse pump faulty.	Call the technical service to replace the pressure switch.
	Pressure switch is broken.	Call the technical service to replace the pressure switch.
Unsatisfactory wash.	Wash arms obstructed.	Clean arms thoroughly.
	Shortage of detergent.	Call the technical service to reset the dispenser.
	Dirty filters.	Clean the filters thoroughly.
	Presence of foam.	Unsuitable detergent. Call the technical service to supply correct detergent.
		Too much rinse aid. Call the technical service to reset the dispenser.
	Temperature of lower tub at 50°C/122°F.	Thermostat faulty or incorrectly set. Call the technical service to repair it.
	Length of cycle too short for level of dirt on dishes.	Select a longer cycle.
Water too dirty.	Drain the wash tub and fill with clean water.	
Dishes and kitchenware are not dry.	There is no rinse aid.	Fill the rinse aid container.
	Rinse aid low.	Call technical service to adjust dispenser.
	Dishes left inside dishwasher for too long.	When the dishwasher finishes, remove the basket from the machine and allow to dry naturally.
	Rinse temperature lower than 80°C/176°F.	Call technical service to analyze problem.
Scratches or stains on dishes.	Too much rinse aid.	Call technical service to adjust rinse aid dispenser.
	Water too chalky.	Check water hardness.

FAULT	POSSIBLE CAUSE	SOLUTION
Machine stops during operation.	Electrical installation overloaded.	Call technical service to modify electrical installation.
	Machine protection has tripped.	Reset safety device and if it trips again, call technical service.
Machine stops and fills with water when it is washing.	Pressure switch pipe blocked.	Empty the tub and clean thoroughly.
	Pressure switch faulty.	Call the technical service to replace it.
	Overflow incorrectly mounting.	Mount overflow correctly.
The machine does not start with the wash cycle.	Hood/door is not closed properly.	Close the hood/door correctly and if it is seen to reopen alone, call the technical services to adjust the tensioners.
	Hood/door micro switch faulty.	Call the technical service to replace it.
Machine does not drain completely.	Machine not leveled correctly.	Level the machine. In the event of doubt, please contact your technical service.
	Pressure switch faulty.	Call the technical service to replace the pressure switch.



NOTE: If a fault occurs and is not listed in the above table, please call the technical service. The manufacturer reserves the right to modify the technical characteristics with prior warning.

ERROR DISPLAYED	DESCRIPTION	SOLUTION
E1/bP	Boiler probe failure	Call Service technician
E2/tP	Tank probe failure	Call Service technician
E3/bo	Boiler overheating	Check if water supply is turned 'ON'
		Call Service technician
E4/to	Tank overheating	Check if water supply is turned 'ON'
		Call Service technician
E5/bh	Boiler heat element failure	Call Service technician
E6/th	Tank heat element failure	Call Service technician
E7/dr	Draining failure	Check tank drain is not blocked
		Check the drain hose is not blocked
		Call Service technician
E8/bF	Boiler not filling	Check if water supply is turned 'ON'
		Check if overflow tube is installed
		Check if drain hose has fallen and below tank drain
		Check if drain hose has fallen and below tank drain
E9/tF	Tank not filling	Check if water supply is turned 'ON'
		Check if overflow tube is installed
		Call Service technician
E10/rS	Rinse error	Call Service technician
do/or	Door is open	Close door
		Call Service technician

For Service or Technical support Call 717-381-4844