

4246 MIXER-GRINDER TECHNICAL MANUAL

SPECIFICATION SHEET

INSTALLATION INSTRUCTIONS

OPERATION INSTRUCTIONS

CLEANING INSTRUCTIONS

TROUBLE SHOOTING INSTRUCTIONS

WIRING DIAGRAMS

CATALOG OF REPLACEMENT PARTS

SMARTPARTS™ USER GUIDE

RECOMMENDED SPARE PARTS LIST

Need other Hobart Services?



- [Warranty Registration](#)
- [Delivery and Installation](#)
- [Preventive Maintenance](#)
- [Hobart Service Contracts](#)
- [Extended Warranty Contracts](#)
- [Parts and Accessories](#)
- [Specialty Programs](#)
- [Water Treatment Programs](#)



HOBART701 S Ridge Avenue, Troy, OH 45374
1-888-4HOBART • www.hobartcorp.com**4246
MIXER-GRINDER****HOBART****STANDARD FEATURES**

- 140 Lb. Hopper Capacity, 55 to 60 lb. per Minute Output
- Exclusive WEDGE Cylinder Insures Full Rate Feeding for the Entire Batch
- Grind Motors –
 - 4246S - 5 H.P.
 - 4246HD - 7½ H.P.
- 1 H.P. Mix Motor
- Grinder Hooper Constructed of Glass Bead Finished Stainless Steel
- Stainless Steel Panels Enclose the Base Assembly and Motors; Mixing Arm and Conveyor Screw are Tinned, End Ring and Cylinder are Stainless Steel
- Nickel Chrome Plated Legs
- Up-Front, Easy-To-Reach Controls
- Easily Converted Hopper Lid for Right or Left Side Hopper Loading
- Pneumatic Foot Control Option

VOLTAGES

- 208/60/3
- 380-415/50/3

**MODELS**

- 4246S – Standard Mixer-Grinder
- 4246HD – Heavy-Duty Mixer-Grinder

OPTIONS

- 7½ H.P. Grind Motor (Model 4246HD for mixed fresh and frozen applications) (not available in 208-240/60/1 electrical spec)
- Pneumatic Foot-Control
- Non-Adjustable Legs with Casters - 7⅝" (same height as stationary legs)
- Adjustable Legs with Casters in Two Different Height Ranges (Heights are measured from floor to base of frame):
 - Short - 9¾" - 12¼"
 - Long - 12⅜" - 17½"

Specifications, Details and Dimensions on Reverse Side.

**4246 MIXER-GRINDER**

4246 MIXER-GRINDER



701 S Ridge Avenue, Troy, OH 45374
1-888-4HOBART • www.hobartcorp.com

SPECIFICATIONS

GENERAL: The standard machine has a 5 H.P. grind motor, 1 H.P. mix motor, non-adjustable stationary legs, and an 8-foot length cord and plug power connection. Available voltages are 208/60/3 and 380-415/50/3 (only for 7½ H.P.).

ELECTRICAL CONTROLS: Electrical controls consist of waterproof start and stop switches, magnetic contactors, dual motor overload protection and foot switch operation capability. An electrical interlock switch is provided. Whenever the hopper lid is opened, power to the motors is shut off. The hopper lid must be in its proper operating position before the grinder motors can be started.

CAPACITY: The 4246 Mixer-Grinder hopper has meat capacity up to 140 pounds depending on the type of product. The grinding rate is 55 to 60 pounds of fresh boneless beef per minute, first or second cutting through a ⅛" plate; 60 to 65 pounds of pork per minute second cutting through a ⅜" plate. The 4246HD is for fresh or frozen meat tempered to 24°F or higher and can be in flake or stick form.

GRINDING END: The mixer-grinder is equipped with a "Wedge cylinder" grinding end. This grinding end is sized for #32 knives and plates (not included but optionally available).

FEEDING SYSTEM: The 4246 is powered by two separate drive systems. A 1 H.P. motor drives the heavy-duty steel mixing arm. The arm rotates at 23 rpm and can easily be removed from the hopper for cleaning. The conveyor screw extends the full length of the hopper and the cylinder. The screw rotates at a speed of 194 rpm and it is driven by a 5 H.P. motor in the standard unit (4246S); the motor in the heavy-duty unit (4246HD) is a 7½ H.P. motor. By depressing the MIX/GRIND START button both the mixing arm and the screw are operated. Both mixing and grinding are stopped when the STOP switch is depressed.

CLEANING: The mixing arm, conveyor screw, cylinder, and conveyor screw drive-shaft seal are removable from the grinder for cleaning.

FINISH: The grinder consists of glass bead finished stainless steel hopper; stainless steel panels to enclose the base assembly and motors. The mixing arm and conveyor screw are tinned. The end ring and cylinder are stainless steel. The legs are nickel chrome plated.

DETAILS AND DIMENSIONS

LEG	DIM 'A'	DIM 'B'	DIM 'D'	DIM 'F'
STANDARD & CASTER	7 ¹⁵ / ₁₆ "	24 ⁷ / ₁₆ "	49 ¹⁵ / ₁₆ "	71 ⁵ / ₁₆ "
SH ADJ CASTER (MIN)	10 ¹ / ₁₆ "	26 ⁷ / ₁₆ "	52 ¹ / ₁₆ "	73 ⁷ / ₁₆ "
SH ADJ CASTER (MAX)	12 ¹ / ₄ "	28 ³ / ₄ "	54 ¹ / ₄ "	75 ⁵ / ₈ "
LG ADJ CASTER (MIN)	12 ¹¹ / ₁₆ "	29 ⁹ / ₁₆ "	54 ¹¹ / ₁₆ "	76 ¹ / ₁₆ "
LG ADJ CASTER (MAX)	17 ¹ / ₂ "	34"	59 ¹ / ₂ "	80 ⁵ / ₈ "

ELECTRICAL SPECIFICATIONS	NEMA CONFIGURATION	
	CONNECTOR	RECEPTACLE
208/60/3	L21 - 30P	L21 - 30R

WARNING

ELECTRICAL AND GROUNDING CONNECTIONS MUST COMPLY WITH THE NATIONAL ELECTRICAL CODE AND/OR OTHER LOCAL ELECTRICAL CODES IN FORCE.

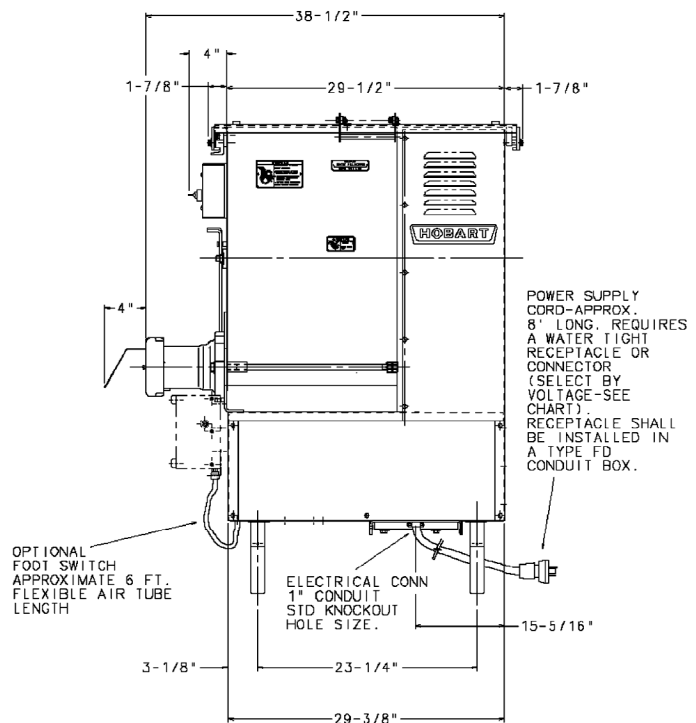
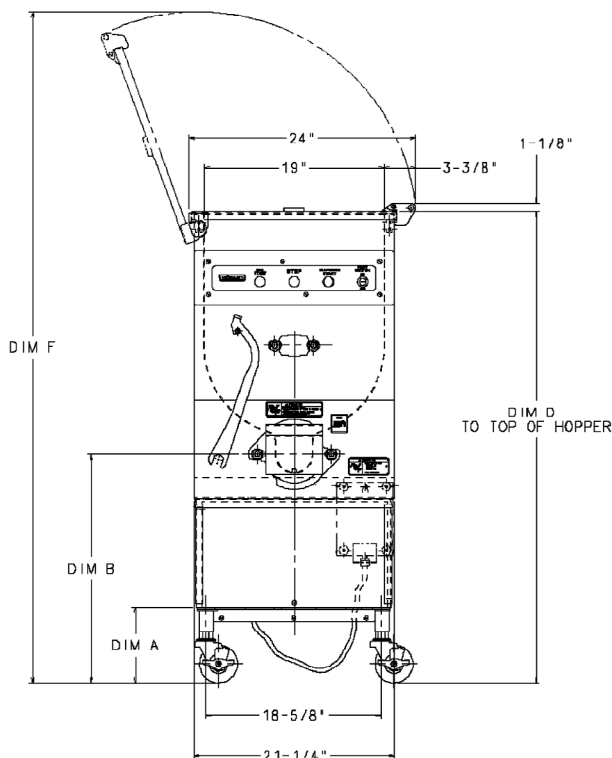

As continued product improvement is a policy of Hobart, specifications are subject to change without notice.

OPERATION

MODEL 4246 MIXER-GRINDER

4246S STANDARD (5 HP/1 HP)

ML-134220

4246HD HEAVY DUTY (7.5 HP/1 HP)

ML-134221



701 S. RIDGE AVENUE
TROY, OHIO 45374-0001

937 332-3000

www.hobartcorp.com

FORM 34850 (Dec. 2002)

Operation and Care of the MODEL 4246 MIXER-GRINDER

SAVE THESE INSTRUCTIONS

GENERAL

The Model 4246 Mixer-Grinder is designed to use #32-size knife and plate assemblies (not included with the unit).

The Model 4246 is equipped with two drive systems. A 1-HP motor drives the heavy-duty steel mixing arm. A 5-HP motor drives the grinder worm in the Standard 4246S unit. There is a 7¹/₂-HP motor, specifically powered for grinding mixed fresh and frozen meat in the Heavy-Duty 4246HD. The data plate is marked 6 HP (total) for the 4246S and 8¹/₂ HP (total) for the 4246HD.

The exclusive Hobart design #46 Wedge cylinder grinding end (Fig. 1) speeds product from hopper to grinding end by pulling pieces of meat through the large upper opening of the cylinder.

The 4246 Mixer-Grinder may be ordered with any of the following options and/or accessories:

- Pneumatic foot switch (can be added at any time)
- Nonadjustable legs with casters
- Adjustable legs with casters in two different height ranges

The hopper lid is designed to open either from the left or the right, depending on your needs. Contact your Hobart representative for further information.

The mixing arm rotates at 23 rpm and the grinder worm at 216 rpm. The 4246 Mixer-Grinder hopper has meat capacity up to 140 lb (64 kg), depending upon the type of product. It has a grinding rate of 55 to 60 lb (25 to 27 kg) of fresh boneless beef per minute, first or second cutting through a 1/8" plate, and a grinding rate of 60 to 65 lb (27 to 29 kg) of fresh boneless pork per minute, second cutting through a 3/16" plate. The 4246HD unit is powered for processing frozen meat tempered to 26°F (-3°C) or higher; the meat can be in flake or stick form.

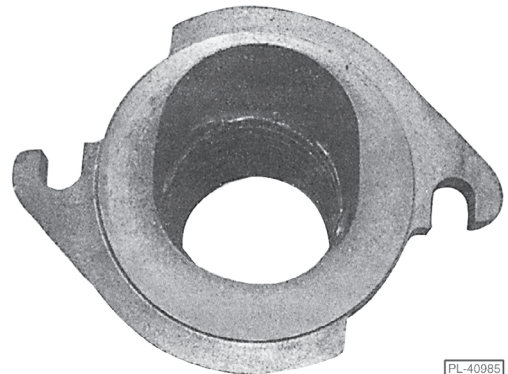

Fig. 1

INSTALLATION

UNPACKING

Immediately after unpacking the mixer-grinder, check for possible shipping damage. If the mixer-grinder is found to be damaged, save the packaging material and contact the carrier within 15 days of delivery.

Remove the packing box by loosening and removing the four bolts through the wooden skid.

To set up the unit, follow the order of assembly below:

1. Legs, shipped in a separate box from the unit, require a $1\frac{5}{16}$ " socket with torque to 50 ft-lb.
2. Lower side panels are packed on top of unit.
3. Remove the spanner wrench and the meat deflector, located inside the hopper.
4. Pneumatic foot switch, if ordered, is shipped in a separate box.

Already assembled within the unit are the conveyor screw, mixing arm and cylinder. Remove the shipping plate and rubber spacer from the chopping end and replace with your #32 knife and plate assembly, not supplied.

LOCATION

Prior to installing the mixer-grinder, verify the electrical supply to make sure that it agrees with the specifications on the machine data plate, which is located under the hopper on the right.

LEVELING

Level the mixer-grinder, both front-to-back and side-to-side, by loosening the two set screws on the caster/leg shaft. Tighten both set screws when level.

LUBRICATION

The mixer-grinder is shipped with oil already installed. If oil loss is observed, the oil levels of both transmissions should be checked prior to operation. Contact a local Hobart Service Office.

PNEUMATIC FOOT SWITCH

To install the pneumatic foot switch:

1. Remove screws from the lower front panel.

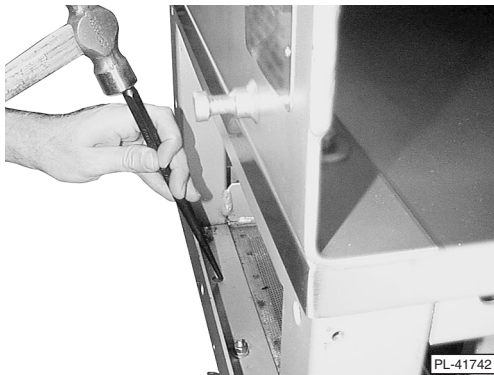

Fig. 2

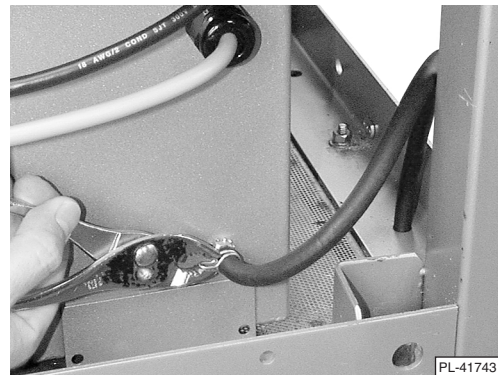

Fig. 3

2. On the front of the machine, locate the lower frame rail; approximately 4" (10.2 cm) from the left side, is a knockout hole for the foot switch control hose. Using a hammer and punch (Fig. 2), tap sharply to remove knockout piece in the sheet metal just beneath the frame rail.
3. Using pliers remove small pinch clamp from hose, save clamp.
4. Thread hose up through knockout hole (Fig. 3).
5. Slide pinch clamp onto hose approximately 2" (5.08 cm) from end of hose.
6. Route the hose around left corner of the control box. Avoid kinking the hose during installation.
7. A small metal nipple is located on the left side of the control box. Remove the protective cap and push hose tightly over the metal nipple.
8. Slide the clamp up the hose and place it within 1/4" (0.653 cm) of the hose end (Fig. 3) to ensure a proper seal.

NOTE: Be absolutely sure hose and clamp are firmly secured to nipple; a loose fit may cause foot controls to malfunction.

9. Reinstall lower front panel with six screws.

ELECTRICAL

WARNING: ELECTRICAL AND GROUNDING CONNECTIONS MUST COMPLY WITH THE APPLICABLE PORTIONS OF THE NATIONAL ELECTRICAL CODE AND/OR OTHER LOCAL ELECTRICAL CODES.

The mixer-grinder is provided with a cord and plug and only requires that it be connected to an appropriately sized, grounding-type receptacle. Refer to the machine data plate.

CHECK MOTOR ROTATION

With the grinder cylinder in place and the hopper lid closed, check the rotation. Standing in front of machine, push the MIX/GRIND START button. Check that the mixing arm and worm rotate counterclockwise; press the STOP button to stop rotation.

If the mixing arm and worm do not rotate counterclockwise, correct the rotation using the following procedure:

1. Disconnect the electrical power supply and interchange any two power supply leads at the receptacle.
2. Reconnect the power supply and push the MIX/GRIND START button.
3. Verify that both the worm and the mixer arm rotate counterclockwise when viewed from the front of the machine.
4. Press the STOP button to stop rotation.

OPERATION IN TANDEM

When the 4246 is used in tandem as a first-cut machine, a special adjusting ring is required. When ordering side-feed adapters for non-Hobart grinders, specify plate size and type. When ordering adjusting rings for Hobart grinders, specify grinder size.

OPERATION

CONTROLS - FIG. 4

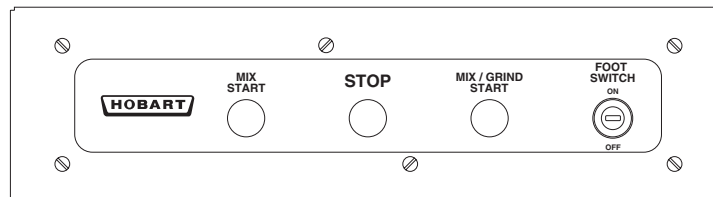

PL-56571

Fig. 4

- | | |
|-----------------|---|
| MIX START | - Starts the mixing arm. |
| STOP | - All operations will be stopped. |
| MIX/GRIND START | - Operates both the mixing arm and the conveyor screw. |
| FOOT SWITCH ON | - The foot switch is used to operate the Mix/Grind mode only. The MIX START and GRIND START buttons are inoperable. |
| FOOT SWITCH OFF | - All buttons are operable. |

NOTE: If the foot switch is in the ON position, pressing the STOP button will stop the machine for as long as the button is held down.

WARNING: IF FOOT CONTROL IS DISASSEMBLED FOR CLEANING OR FOR REPAIR, THE UNIT MUST BE COMPLETELY REASSEMBLED AS MANUFACTURED PRIOR TO CUSTOMER USE.

ASSEMBLY AND USE

Do not use a plate with hole size smaller than $\frac{3}{32}$ ".

Before using the grinding cylinder, take it apart and wash it thoroughly. (See Cleaning instructions.)

Hand-tighten the end ring. Overtightening will damage unit.

The Wedge cylinder is marked TOP and BOTTOM. Before operating, be sure TOP is visible.

The knife and plate need some preliminary lubrication: rub tallow or mineral oil over the cutting surfaces of these parts. Knives and plates must be sharp and true for proper cutting action. The two studs on the front of the hopper allow storage of the spanner wrench and the foot control.

The Model 4246 hopper has a normal total capacity of 140 lb (63.5 kg), depending on the type of meat or product to be processed. Meat may be mixed in the hopper for any desired length of time. During the Mix-Only period, the mixing arm operates; and the hopper conveyor screw does not rotate. Continuous self-feeding occurs along with grinding in the Mix/Grind operation.

To shut hopper lid, lift the locking catch on the front hinge while holding the lid itself with your other hand.

GRINDING PROCEDURE

First Grind . . .

Fill hopper and close and latch the hopper lid. Overfilling will bend the hopper lid and may cause the interlock to open the electrical circuit.

Push MIX/GRIND START button to start grinding. Press STOP button to stop grinding.

Second Grind . . .

Fill hopper and close and latch the hopper lid. Press MIX START button. After desired mixing, press the STOP button. Then, press the MIX/GRIND START button to start grinding, press the STOP button to stop grinding, or activate and use the optional accessory Foot Switch.

MAINTENANCE

WARNING: DISCONNECT THE ELECTRICAL POWER TO THE MACHINE AND FOLLOW LOCKOUT / TAGOUT PROCEDURES.

CLEANING

The Model 4246 Mixer-Grinder is designed for easy cleaning. Stop the grinder and unplug electrical power source before cleaning or servicing. The following components must be removed when cleaning the mixer-grinder: mixing arm, end ring, knife, plate, cylinder and conveyor screw. The grinder attachment is easily cleaned.

1. Use spanner wrench to loosen the adjusting ring and to withdraw the plate, knife and conveyor screw.
2. Inside the hopper, remove the rubber seal at the drive end of the conveyor screw. Grasp the outer flange or use a dull screwdriver tip to pull the seal out.

3. Loosen the two retaining nuts, and remove the mixing arm pilot bushing assembly. Rotate and remove the bushing retainer. Disengage and pull mixing arm from the square drive and lift the arm from the hopper.
4. Wash machine with hot water or steam. When using detergents and sanitizers, follow manufacturer's instructions. Rinse with clear water. Allow to air-dry.
5. When mixer-grinder is clean and dry, apply a light coat of food-grade mineral oil to the cylinder, adjusting ring, knife, plate and worm.
6. Assemble mixing arm, cylinder, end ring, knife, plate and conveyor screw into mixer-grinder.
7. Reconnect electrical power supply.

HEATER

The mixer-grinder is equipped with heaters for the electric control box and operator panel to keep the controls dry. These are automatically on when the unit is electrically connected. The mixer-grinder should always be connected except when cleaning or disassembling unit.

LUBRICATION

Both motor bearings are prelubricated and sealed. No further lubrication is required.

SERVICE

Contact your local Hobart Service Office for any repairs or adjustments needed.

TROUBLESHOOTING

Problem	Possible Cause
Machine will not run.	<ol style="list-style-type: none"> 1. Hopper lid not closed completely. 2. Plug disconnected from receptacle. 3. Circuit breaker tripped.
Poor grind result.	<ol style="list-style-type: none"> 1. Adjusting ring loose. 2. Knife or plate dull. 3. Knife and plate not seated properly. 4. Plate stud broken. 5. Knife broken.

SERVICE

Contact your local Hobart Service Office for any repairs or adjustments needed on this equipment.

WARNING

ELECTRICAL & GROUNDING CONNECTIONS MUST COMPLY WITH THE APPLICABLE PORTIONS OF THE NATIONAL ELECTRICAL CODE AND/OR OTHER LOCAL ELECTRICAL CODES

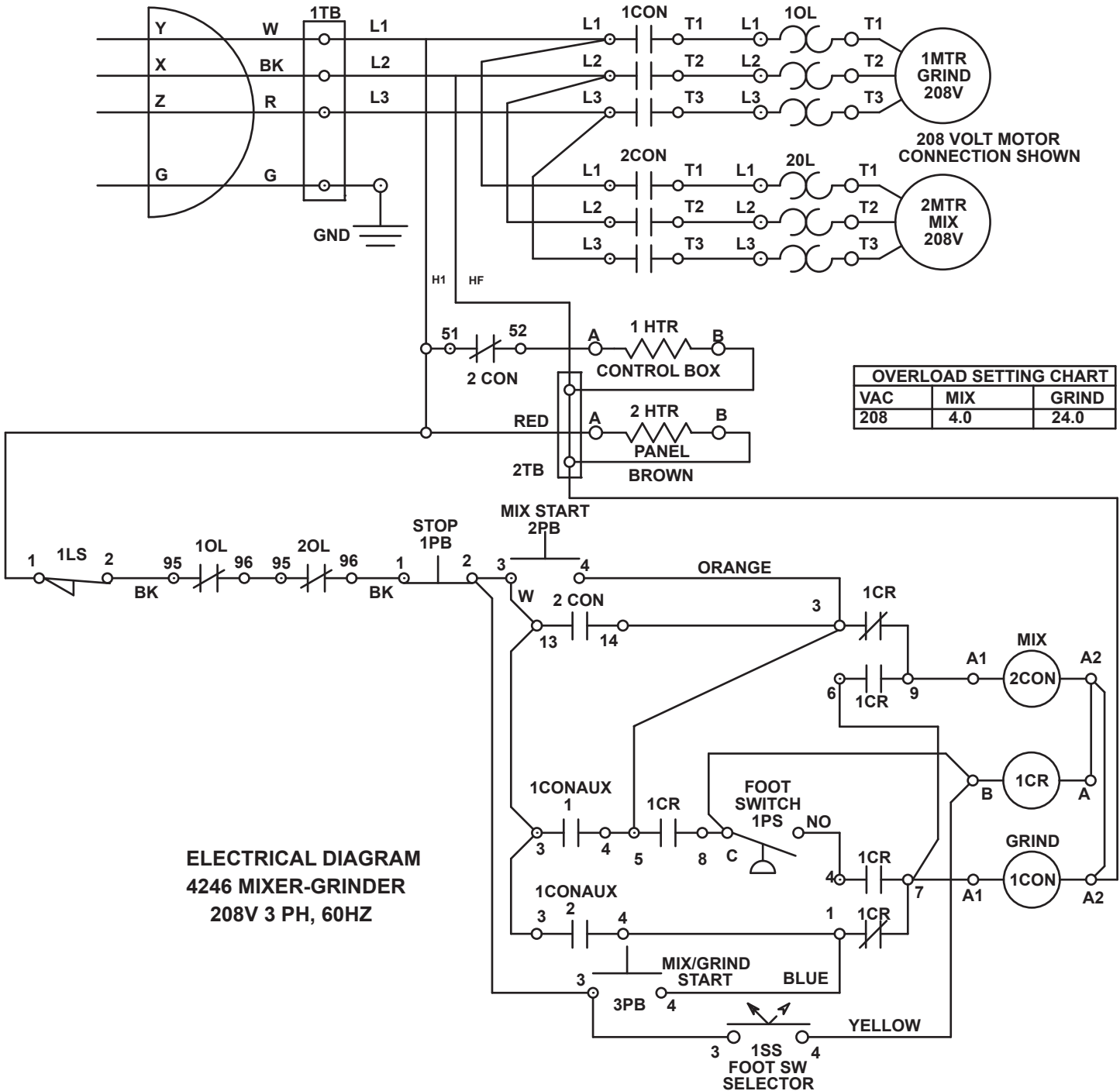
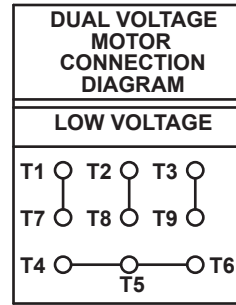

OVERLOAD SETTING CHART		
VAC	MIX	GRIND
208	4.0	24.0

**ELECTRICAL DIAGRAM
4246 MIXER-GRINDER
208V 3 PH, 60HZ**

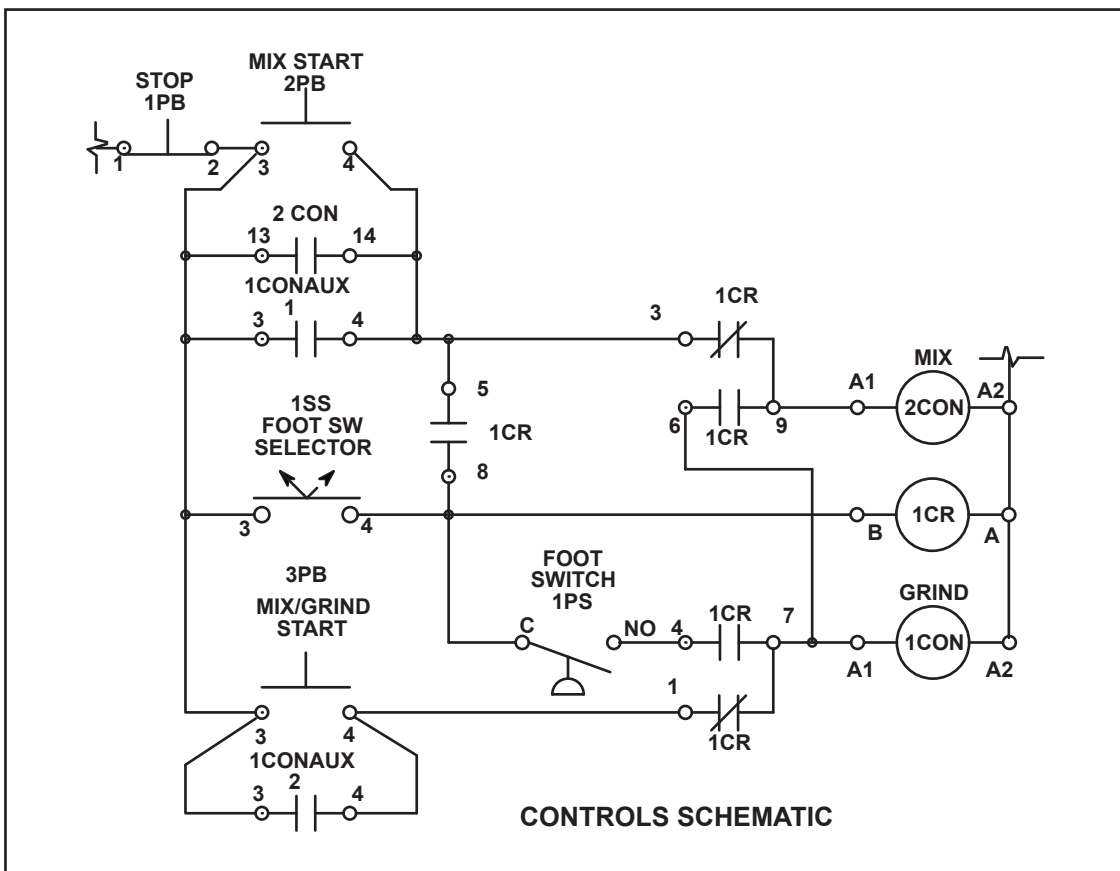

SYMBOL DEFINITIONS

- - - DASHED LINES DENOTE OPTIONAL WIRING
- PB START SWITCH - NORMALLY OPEN (N.O.)
- PB STOP SWITCH - NORMALLY CLOSED (N.C.)
- CONTACT - NORMALLY OPEN (N.O.)
- CONTACT - NORMALLY CLOSED (N.C.)
- LS LIMIT SWITCH - NORMALLY OPEN, HELD CLOSED
- SS SELECTOR-OPTIONAL FOOT SWITCH
- FU FUSE
- PS PRESSURE FOOT SWITCH
- OL OVERLOAD RELAY AND HEATERS
- HTR BOX AIR HEATER
- CON CONTACTOR(R-RIGHT,L-LEFT)
- CR CONTROL RELAY
- INSEPARABLE CONNECTION
- SEPARABLE CONNECTION
- MTR MOTOR
- T TRANSFORMER
- TB TERMINAL BLOCK

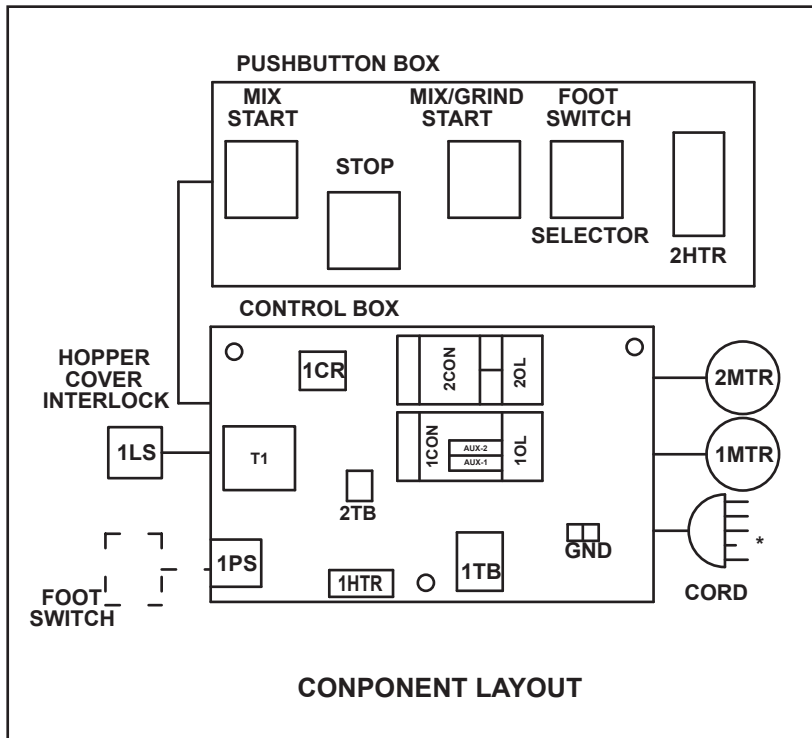



CATALOG OF REPLACEMENT PARTS

MODEL 4246 MIXER-GRINDERS

STANDARD (5 HP./1 HP.)
4246S ML-134220

HEAVY DUTY (7.5 HP./1 HP.)
4246HD ML-134221

PRIOR MLS COVERED IN THIS MANUAL

STANDARD (5 HP./1HP.)
4246S ML-038397
4246S ML-134216

HEAVY DUTY (7.5 HP./1 HP.)
4246HD ML-038401
4246HD ML-134214

Table of Contents

Page	Description
5	Control Box
7	Control Panel (ML-38397 and ML-38401)
9	Control Panel (ML-134214, ML-134216, ML-134220, & ML-134221)
11	Operator's Panel (ML-38397 and ML-38401)
13	Operator's Panel (ML-134214, ML-134216, ML-134220, & ML-134221)
14	Hopper and Frame
17	Grind Transmission (Previous Construction)
19	Grind Transmission (Current Construction)
21	Grind Conveyor and Mixing Arm/Transmission
23	Grind Motor/Drive Unit
25	Mix Arm Motor/Ventilating Unit
27	Foot Switch
29	#32 Grinder
31	Side Feed

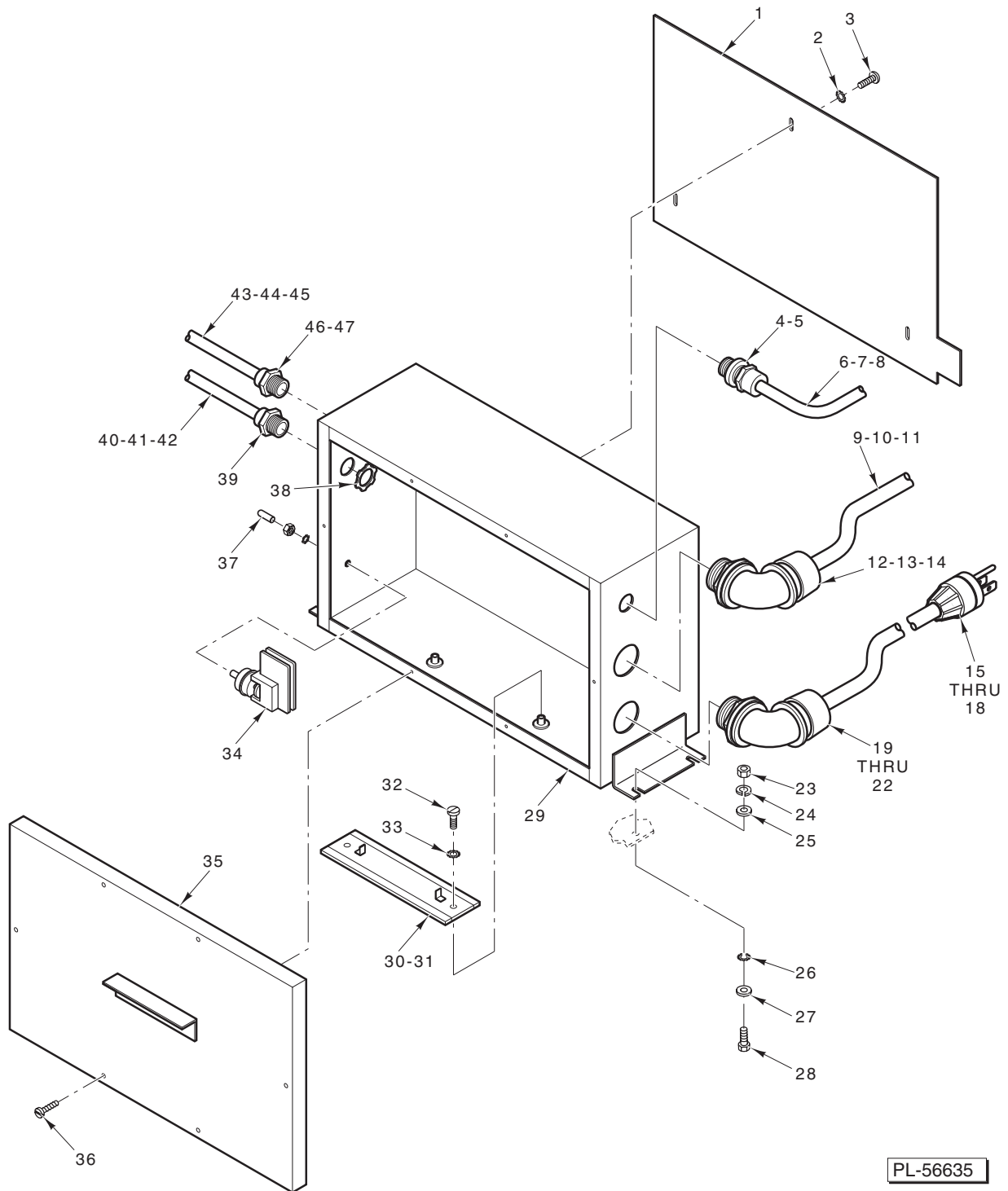

CONTROL BOX

CONTROL BOX

ILLUS.	PART NO.	NAME OF PART	AMT.
	PL-56635		
1	00-292671	Panel – Air Deflector (3 Ph.)	1
2	WL-007-12	Lockwasher #10 External Shakeproof	3
3	SC-008-09	Mach. Screw 10-24 x ³ / ₈ Rd. Hd.	3
4	FE-022-84	Strain Relief	1
5	FE-024-88	Lock Nut Electrical ¹ / ₂	1
6	00-294853-00041	Cable – Mix Motor Control (ML-134214 & ML-134216)	1
7	00-294853-00002	Cable – Mix Motor Control (3 Ph.) (ML-38397 & ML-38401)	1
8	00-294853-00007	Cable – Mix Motor Control (1 Ph.) (ML-38397)	1
9	00-294853-00052	Cable – Grind Motor Control (ML-134214 & ML-134216)	1
10	00-294853-00001	Cable – Grind Motor Control (3 Ph.) (ML-38397 & ML-38401)	1
11	00-294853-00008	Cable – Grind Motor Control (1 Ph.) (ML-38397)	1
12	FE-023-41	Strain Relief	1
13	FE-006-50	Lock Nut Electrical 1	1
14	FE-008-12	Gasket – Electrical	1
15	00-478551-00001	Cord/Plug Assy. (208 V., 3 Ph.)	1
16	00-478551-00002	Cord/Plug Assy. (240 V., 3 Ph.)	1
17	00-117612-00016	Cord/Plug Assy. (480 V., 3 Ph.)	1
18	00-294899-00001	Cord/Plug Assy. (208-240 V., 1 Ph.)	1
19	FE-023-42	Strain Relief (208 V., 3 Ph.; 208-240 V., 1 Ph.)	1
20	FE-023-41	Strain Relief (380-415 V., 50 Hz., 3 Ph.; 240-480 V., 60 Hz., 3 Ph.)	1
21	FE-006-50	Lock Nut Electrical 1	1
22	FE-008-12	Gasket – Electrical	1
23	NS-015-01	Nut Hex ¹ / ₄ -20	4
24	WL-006-17	Lockwasher ¹ / ₄ Helical	4
25	WS-017-06	Washer	4
26	WS-017-06	Washer	4
27	WL-007-16	Lockwasher ¹ / ₄ External Shakeproof	4
28	SC-041-01	Cap Screw ¹ / ₄ -20 x ³ / ₄ Hex Hd.	4
29	00-186704-00001	Box Wldt. – Lower Control	1
30	00-478220-00001	Heater (208 V.) (ML-134214 & ML-134216)	1
31	00-478220-00002	Heater (240 V.) (ML-134214)	1
32	SC-018-11	Mach. Screw 10-24 x ³ / ₈ Slotted Pan Hd.	2
33	WL-007-12	Lockwasher #10 External	2
34	00-087711-213-1	Switch – Air Activated	1
35	00-186771	Lid & Gasket Assy.	1
36	SD-036-39	Self-Tapping Screw 10-24 x ³ / ₈ Truss Hd., Type TT	6
37	00-294855-00001	Cap	1
38	FE-024-88	Lock Nut Electrical ¹ / ₂	1
39	FE-022-84	Relief – Strain, Electrical	1
40	00-294853-00051	Cable – Control Switch (ML-134214 & ML-134216)	1
41	00-294853-00003	Cable – Control Switch (3 Ph.) (ML-38397 & ML-38401)	1
42	00-294853-00009	Cable – Control Switch (1 Ph.) (ML-38397)	1
43	00-294853-00038	Cable – Interlock Switch (ML-134214 & ML-134216)	1
44	00-294853-00004	Cable – Interlock Switch (3 Ph.) (ML-38397 & ML-38401)	1
45	00-294853-00006	Cable – Interlock Switch (1 Ph.) (ML-38397)	1
46	FE-022-84	Strain Relief	1
47	FE-024-88	Lock Nut Electrical ¹ / ₂	1

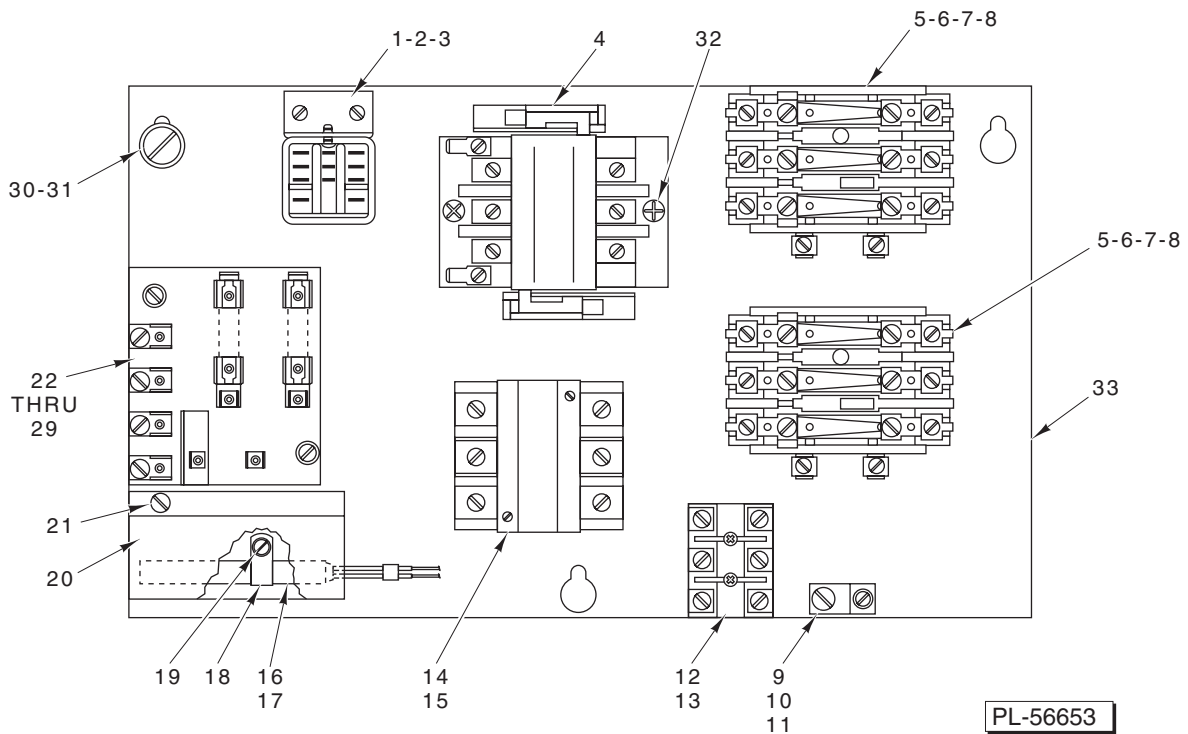

**CONTROL PANEL
(ML-38397 AND ML-38401)**

**CONTROL PANEL
(ML-38397 AND ML-38401)**

ILLUS. PL-56653	PART NO.	NAME OF PART	AMT.
1	00-087714-020-3	Relay – 3 P.D.T.	1
2	00-186748	Relay Mounting	1
3	SD-009-24	Self-Tapping Screw 6-32 x 3/8 Slotted Rd. Hd., Type F	4
4	00-087713-030-1	Contactactor	1
5	SD-009-08	Self-Tapping Screw 8-32 x 3/8 Slotted Bndg. Hd., Type F	4
6	00-088196-009-1	Relay – Thermal Overload (3 Ph.) (208-240/480 V.) (W/Overload Protection)	2
7	00-088196-006-1	Relay – Thermal Overload (1 Ph.) (W/Overload Protection)	2
8	-	Heater Elements (Give Elec. Spec.)	AR
9	00-118544-00001	Lug – Solderless	1
10	SD-009-12	Self-Tapping Screw 10-32 x 3/8 Slotted Rd. Hd., Type F	1
11	WL-007-12	Lockwasher #10 External Shakeproof	AR
12	00-294325-003-1	Block – Terminal	AR
13	SD-029-11	Self-Tapping Screw 6-32 x 1 Phil. Pan Hd., Type F	2
14	00-087713-071-1	Contactactor (50A, 3 Pole)	1
15	SD-009-08	Self-Tapping Screw 8-32 x 3/8 Slotted Bndg. Hd., Type F	2
16	00-108202-00002	Heater	1
17	00-292708	Spacer – Heater	2
18	00-108199-00001	Clamp – Air Heater	1
19	SD-009-09	Self-Tapping Screw 8-32 x 1/2 Slotted Bndg. Hd., Type F	1
20	00-108101	Shield – Heater	1
21	SD-009-08	Self-Tapping Screw 8-32 x 3/8 Slotted Bndg. Hd., Type F	1
22	00-114707	Terminal & Mounting Board Assy. (480 V.)	1
23	00-293555-00002	Transformer & Terminal Assy. (480 V., 60 Hz.)	1
24	00-293555	Transformer & Terminal (480 V., 50 Hz.)	1
25	FE-022-74	Fuse (Buss #FNQ-6/10)	2
26	SC-019-33	Mach. Screw 8-32 x 1/2 Slotted Bndg. Hd.	2
27	NS-009-12	Mach. Nut 8-32 Hex	2
28	WL-007-07	Lockwasher #8 External Shakeproof	2
29	SD-009-08	Self-Tapping Screw 8-32 x 3/8 Slotted Bndg. Hd., Type F	2
30	SC-008-09	Mach. Screw 10-24 x 3/8 Slotted Rd. Hd.	3
31	WL-007-12	Lockwasher #10 External Shakeproof	3
32	SD-009-08	Self-Tapping Screw 8-32 x 3/8 Slotted Bndg. Hd., Type F	2
33	00-186727	Plate – Control Mounting	1
	00-293215	Barrier – Control Box (480 V., 50 Hz.)	1

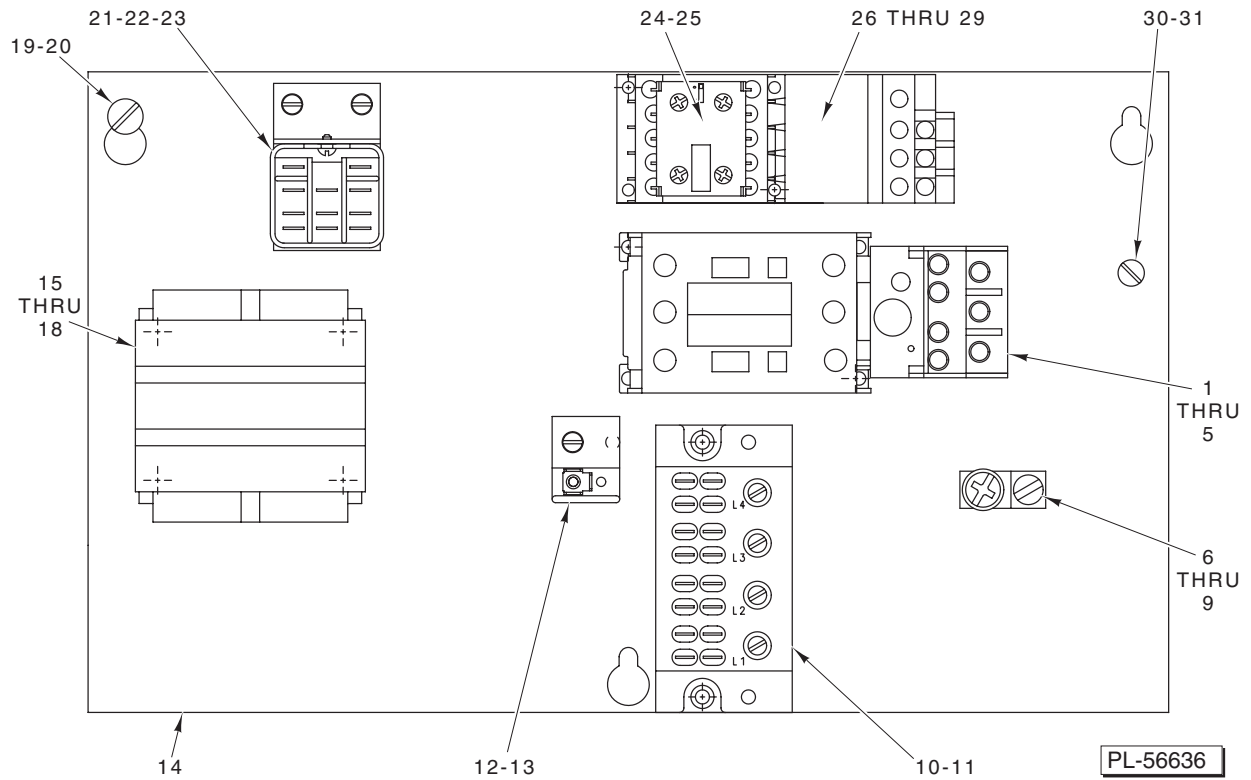

CONTROL PANEL
(ML-134214, ML-134216, ML-134220, & ML-134221)

CONTROL PANEL
(ML-134214, ML-134216, ML-134220, & ML-134221)

ILLUS. PL-56636	PART NO.	NAME OF PART	AMT.
1	00-087713-094-2	Contactactor (208 V., 60 Hz., 3 Ph.)	1
2	00-087713-094-3	Contactactor (380-415 V., 50 Hz., 3 Ph.)	1
3	00-088186-024-2	Relay – Overload (380-415 V., 50 Hz., 3 Ph.)	1
4	00-088186-024-1	Relay – Overload (208 V., 60 Hz., 3 Ph.)	1
5	SD-009-09	Self-Tapping Screw 8-32 x 1/2 Slotted Bndg. Hd.	2
6	00-118544-00002	Lug	1
7	SC-114-29	Mach. Screw 1/4-20 x 3/8 Phil. Pan Hd.	1
8	WL-007-14	Lockwasher 1/4 External	1
9	NS-046-38	Mach. Nut 1/4-20 Hex (SST)	1
10	00-294325-00021	Block – Terminal (4 Pole)	1
11	SD-038-03	Self-Tapping Screw 10-16 x 3/4 Slotted Truss Hd., Type B (SST)	2
12	00-873203-00002	Block – Terminal (Modified)	1
13	SD-009-24	Self-Tapping Screw 6-32 x 3/8 Slotted Rd. Hd., Type F	1
14	00-186727	Plate – Control Mounting	1
15	00-478962	Transformer & Fuse Block Assy. (380-415 V., 50 Hz., 3 Ph.)	1
16	SD-009-08	Self-Tapping Screw 8-32 x 3/8 Slotted Bndg. Hd., Type F	4
17	FE-025-20	Fuse (0.2 Amp.) (600 V.) (380-415 V., 50 Hz., 3 Ph.)	2
18	FE-025-58	Fuse (0.3 Amp.) (600 V.) (380-415 V., 50 Hz., 3 Ph.)	1
19	SC-008-09	Mach. Screw 10-24 x 3/8 Slotted Rd. Hd.	3
20	WL-007-12	Lockwasher #10 External	3
21	00-186748	Bracket – Relay Mounting	1
22	00-087714-020-3	Relay 3 P.D.T.	1
23	SD-009-24	Self-Tapping Screw 6-32 x 3/8 Slotted Rd. Hd., Type F	4
24	00-087711-00266	Switch - Auxiliary	1
25	SD-038-96	Self-Tapping Screw 6-32 x 1/2 Slotted Phil. Rd. Hd., Type F	2
26	00-087713-089-3	Contactactor (208 V., 60 Hz., 3 Ph.)	1
27	00-087713-089-2	Contactactor (380-415 V., 50 Hz., 3 Ph.)	1
28	00-088196-017-1	Relay – Overload (208 V., 60 Hz., 3 Ph.)	1
29	00-088196-017-2	Relay – Overload (380-415 V., 50 Hz., 3 Ph.)	1
30	SD-009-08	Self-Tapping Screw 8-32 x 3/8 Slotted Bndg. Hd., Type F	1
31	WL-007-12	Lockwasher #10 External	1

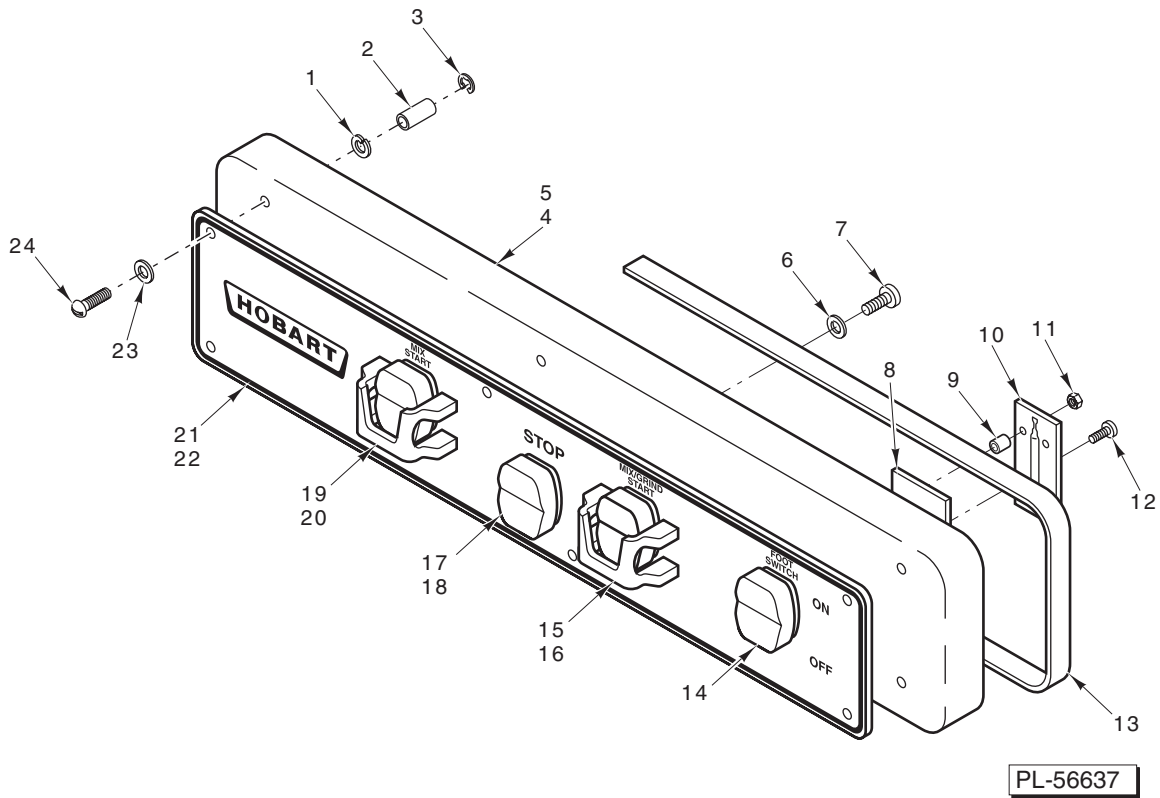

**OPERATOR'S PANEL
(ML-38397 AND ML-38401)**

**OPERATOR'S PANEL
(ML-38397 AND ML-38401)**

ILLUS. PL-56637	PART NO.	NAME OF PART	AMT.
1	WL-006-17	Lockwasher 1/4 Helical (SST)	6
2	00-292917	Spacer – Switch Cover	6
3	00-067500-00058	O-Ring	6
4	00-186736-00001	Switch Cover Assy. (60 Hz.)	1
5	00-292998-00001	Switch Cover Assy. (50 Hz.)	1
6	WS-002-14	Washer	8
7	00-123109	Screw 6-32 x 3/8 Serrated Hd.	8
8	00-124022	Insulator – Reed Mounting Board	4
9	00-118349-00003	Spacer – Control Panel	16
10	00-294854	Reed Mounting Board Assy.	4
11	NS-031-01	Stop Nut – Special	8
12	SD-009-40	Self-Tapping Screw 6-32 x 3/4 Phil. Pan Hd., Type F	8
13	00-102825-00003	Gasket (Switch Cover)	1
14	00-120872-00003	Switch – Select	1
15	00-186739	Guard – Switch	1
16	00-120872-00002	Switch – Start	1
17	00-120872-00004	Switch – Stop (60 Hz.) (Shown)	1
18	00-087711-223-1	Switch – Push Pull (50 Hz.)	1
19	00-186739	Guard – Switch	1
20	00-120872-00002	Switch – Start	1
21	00-186741	Panel – Trim (60 Hz.)	1
22	00-292997	Panel – Trim (50 Hz.)	1
23	WS-017-06	Washer (SST)	6
24	SC-117-90	Mach. Screw 1/4-20 x 1 3/8 Slotted Rd. Hd. (SST)	6

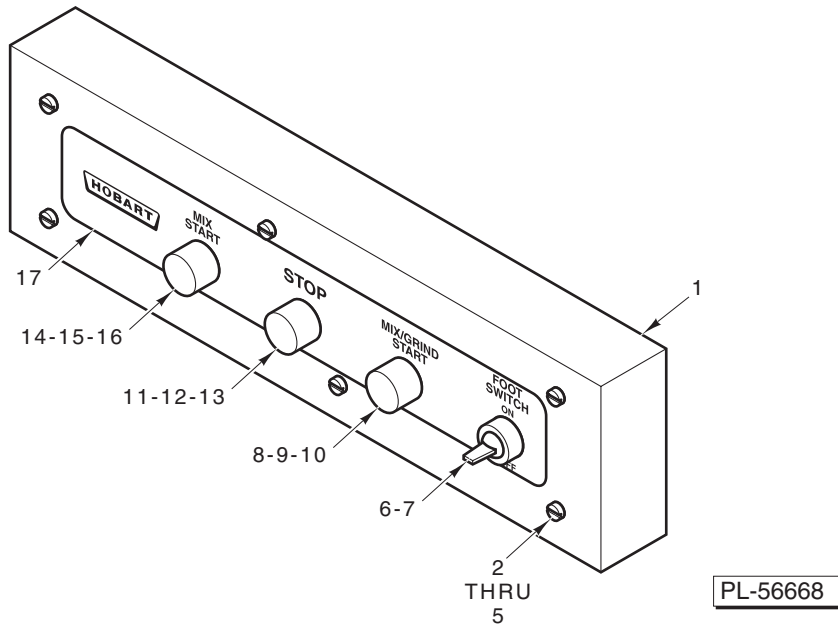

**OPERATOR'S PANEL
(ML-134214, ML-134216, ML-134220, & ML-134221)**

OPERATOR'S PANEL
(ML-134214, ML-134216, ML-134220, & ML-134221)

ILLUS. PL-56668	PART NO.	NAME OF PART	AMT.
1	00-875455	Box – Operator Control Wldt.	1
2	SC-128-44	Mach. Screw 1/4-20 x 2 1/4 Slotted Rd. Hd. (SST)	6
3	WL-006-17	Lockwasher 1/4 Helical (SST)	6
4	00-875537	Spacer	6
5	00-067500-00058	O-Ring	6
6	00-478752-00005	Switch – Select	1
7	00-087711-322-3	Block – Contact	1
8	00-478752-00003	Switch – Start	1
9	00-873427	Cap – Protective	1
10	00-087711-322-3	Block – Contact	1
11	00-478752-00008	Switch – Stop	1
12	00-873427-00002	Cap – Protective	1
13	00-087711-322-5	Block – Contact	1
14	00-478752-00003	Switch – Start	1
15	00-873427	Cap – Protective	1
16	00-087711-322-3	Block – Contact	1
17	00-875456	Trim – Panel	1
	00-875532	Panel Assy. (Incls. Items 1 thru 17)	1
	00-522898	Tie – Cable	3
	SC-021-14	Mach. Screw 8-32 x 3/8 Slotted Rd. Hd. (SST)	2
	WL-014-05	Lockwasher #8 External	2
	SC-060-85	Mach. Screw 10-24 x 1 Slotted Rd. Hd.	1
	00-478220-00001	Heater (208 V.)	1
	00-478220-00002	Heater (240 V.)	1
	SC-041-50	Cap Screw 1/4-20 x 1/2 Hex Hd. (SST) (Use W/478220)	2
	WS-017-06	Washer (Use W/478220)	2
	WL-010-01	Lockwasher #8 External (Use W/478220)	2
	00-520228	Adhesive – Loctite (Use W/478220)	AR

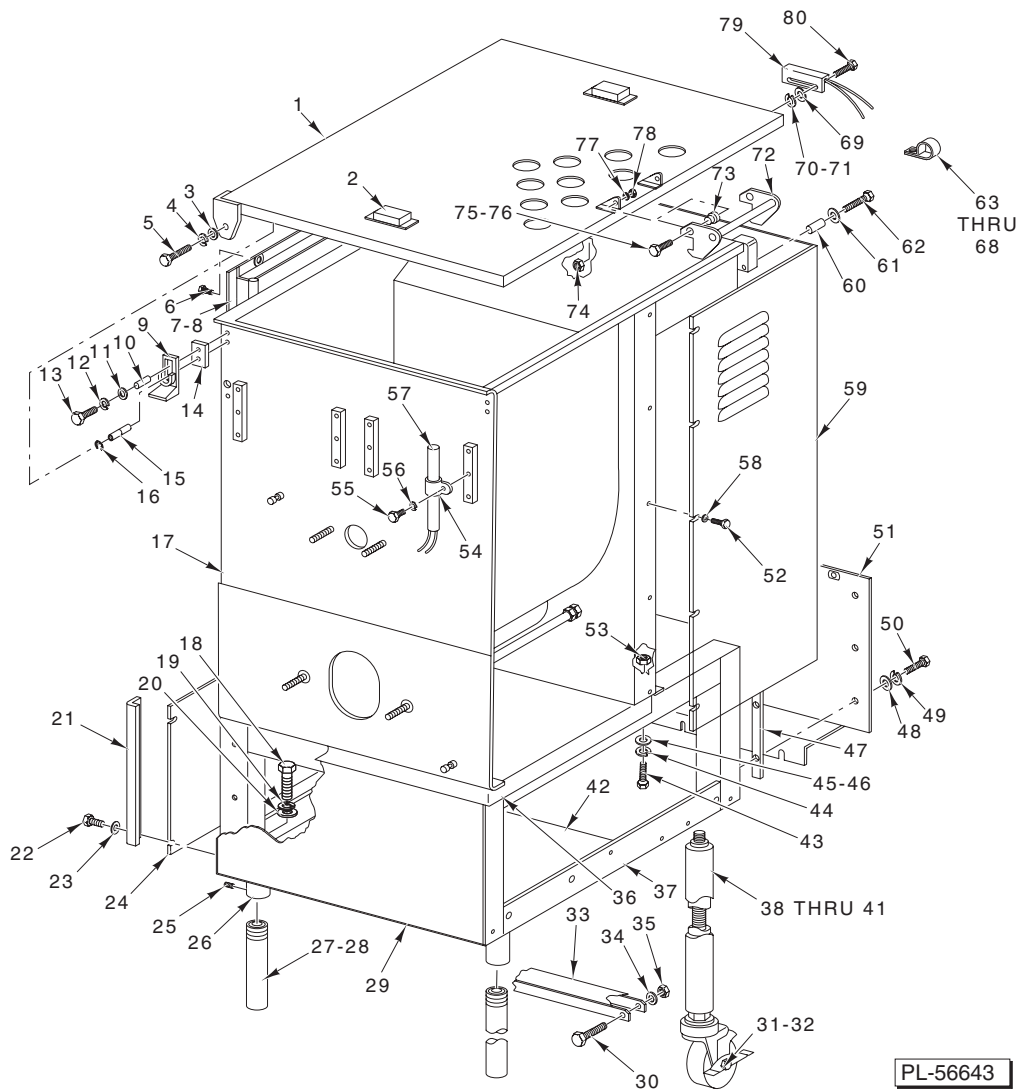

HOPPER AND FRAME

ILLUS.	PART NO.	NAME OF PART	AMT.
	PL-56643		
1	00-186742	Lid Assy. (Incls. Item 2)	1
2	00-290160	Magnet	2
3	WS-008-48	Washer (SST)	1
4	WL-006-23	Lockwasher 5/16 Helical (SST)	1
5	SC-120-99	Cap Screw 5/16-18 x 2 1/4 Hex Hd.	1
6	SC-053-05	Mach. Screw 10-24 x 3/8 Slotted Truss Hd. (SST)	2
7	00-186753	Raceway & Gasket Assy. (Incls. Item 8)	1
8	00-102825-00004	Gasket (Raceway)	1
9	00-186654	Block – Cover Stop	1
10	00-186661-00001	Bushing – Pivot	1
11	WS-005-39	Washer (SST)	1
12	WL-006-23	Lockwasher 5/16 Helical (SST)	1
13	SC-120-32	Cap Screw 5/16-18 x 1 1/2 Hex Hd.	1
14	00-186663	Spacer – Block	1
15	00-186625	Bushing – Pivot	1
16	RR-004-05	Retaining Ring	1
17	00-186683-00001	Hopper (Std.)	1
18	SC-062-51	Cap Screw 5/8-11 x 1 1/2 Hex Hd.	4
19	WL-004-20	Lockwasher 5/8 Helical	4
20	WS-030-07	Washer	4
21	00-186643	Cover – Corner Angle	4

HOPPER AND FRAME (Cont.)

ILLUS.	PART NO.	NAME OF PART	AMT.
	PL-56643		
22	SD-036-39	Self-Tapping Screw 10-24 x 3/8 Slotted Truss Hd., Type T (SST)	8
23	WS-019-10	Washer	8
24	00-186653	Cover – Side	2
25	SC-117-84	Set Screw 1/4-20 x 5/16 Hex Hdls., Cup Pt. (SST)	8
26	00-186722	Leg	4
27	00-186669	Foot	4
28	00-186730	Leg Assy. (Std. W/Foot) (Incls. Items 18, 19, 20, 25, 26, & 27)	4
29	00-186651	Cover – Front Panel	1
30	SC-097-16	Cap Screw 1/4-20 x 2 3/4 Hex Hd.	2
31	00-186724	Caster – Rigid	AR
32	00-186725	Caster – Locking (Swivel)	AR
33	00-292902	Bracket – Rigid Caster	1
34	WL-006-17	Lockwasher 1/4 Helical (SST)	2
35	NS-015-01	Nut 1/4-20 Hex (SST)	2
36	00-186652	Cover – Top	1
37	00-186620	Frame	1
38	00-292904	Adjustable Leg & Rigid Caster Assy. (Frt. Long Adj.) (17 1/2 Max) (Incls. Item 31)	AR
39	00-292602	Adjustable Leg & Swivel Caster Assy. (Long Adj.) (17 1/2 Max) (Incls. Item 32)	AR
40	00-292605	Adjustable Leg & Swivel Caster Assy. (Short Adj.) (12 1/4 Max) (Incls. Item 32)	AR
41	00-186731	Leg Assy. (Std. W/Casters) (Incls. Items 18, 19, 20, 25, 26, & 32)	4
42	00-186686-00001	Cover – Frame Bottom	1
43	SC-041-31	Cap Screw 3/8-16 x 1 1/4 Hex Hd. (SST)	7
44	WL-006-28	Lockwasher 3/8 Helical (SST)	7
45	WS-018-04	Washer (SST)	7
46	WS-030-05	Washer (SST)	7
47	00-186695	Plate – Nut	2
48	WS-017-08	Washer (SST)	6
49	WL-006-23	Lockwasher 5/16 Medium (SST)	6
50	SC-041-11	Cap Screw 5/16-18 x 3/4 Hex Hd. (SST)	6
51	00-186650-00001	Cover – Lower Back	1
52	SD-036-39	Self-Tapping Screw 10-24 x 3/8 Slotted Truss Hd., Type TT (SST)	AR
53	NS-015-13	Nut 3/8-16 Hex (SST)	7
54	00-108199-00001	Clamp – Air Heater (ML-38397 & ML-38401 – Previous Construction)	1
55	SC-009-56	Mach. Screw 8-32 x 3/8 Slotted Rd. Hd.	1
56	WL-010-01	Lockwasher #8 External Shakeproof	1
57	00-122345-00003	Heater Assy. (Ceramic) (ML-38397 & ML-38401 – Previous Construction)	1
58	WS-019-10	Washer (SST)	AR
59	00-186645-00001	Cover – Top Back	1
60	00-186661-00002	Bushing – Pivot	1
61	WL-006-23	Lockwasher 5/16 Helical (SST)	1
62	SC-120-32	Cap Screw 5/16-18 x 1 1/2 Hex Hd.	1
63	00-078752-00001	Clamp 1 1/16 (ML-134214 & ML-134216)	1
64	00-078752-00002	Clamp 1 1/4 P (ML-134214)	1
65	SC-062-50	Cap Screw 10-24 x 5/8 Hex Hd.	1
66	WS-019-10	Washer (SST)	1
67	WL-006-07	Lockwasher #10 Helical (SST)	1
68	NS-009-22	Mach. Nut 10-24 Hex	1
69	WS-019-10	Washer (SST)	2
70	NS-009-22	Mach. Nut 10-24 Hex	2
71	WL-006-07	Lockwasher #10 Helical (SST)	2
72	00-186698	Handle Assy.	1
73	00-289854	Pivot – Lid Stop	2
74	NS-010-16	Mach. Nut 10-24 Hex (Brass) (Mounts Reed Interlock Switch)	2
75	SC-041-01	Cap Screw 1/4-20 x 3/4 Hex Hd. (SST)	2
76	00-520228	Adhesive – Loctite	AR
77	WL-006-17	Lockwasher 1/4 Helical	2
78	NS-025-04	Acorn Nut 1/4-20	2
79	00-087711-215-2	Switch – Reed (Interlock)	1
80	SC-062-30	Cap Screw 10-24 x 5/8 Hex Hd.	2
	00-295269	Leg Assy. (Set of 4, Std. W/Foot) (Packaged)	1
	00-295271	Leg Assy. (Set of 4, Std. W/Caster) (Packaged)	1
	00-295276	Leg Assy. (Set of 4, Short Adj.) (Packaged)	1
	00-295282	Leg Assy. (Set of 4, Long Adj.) (Packaged)	1

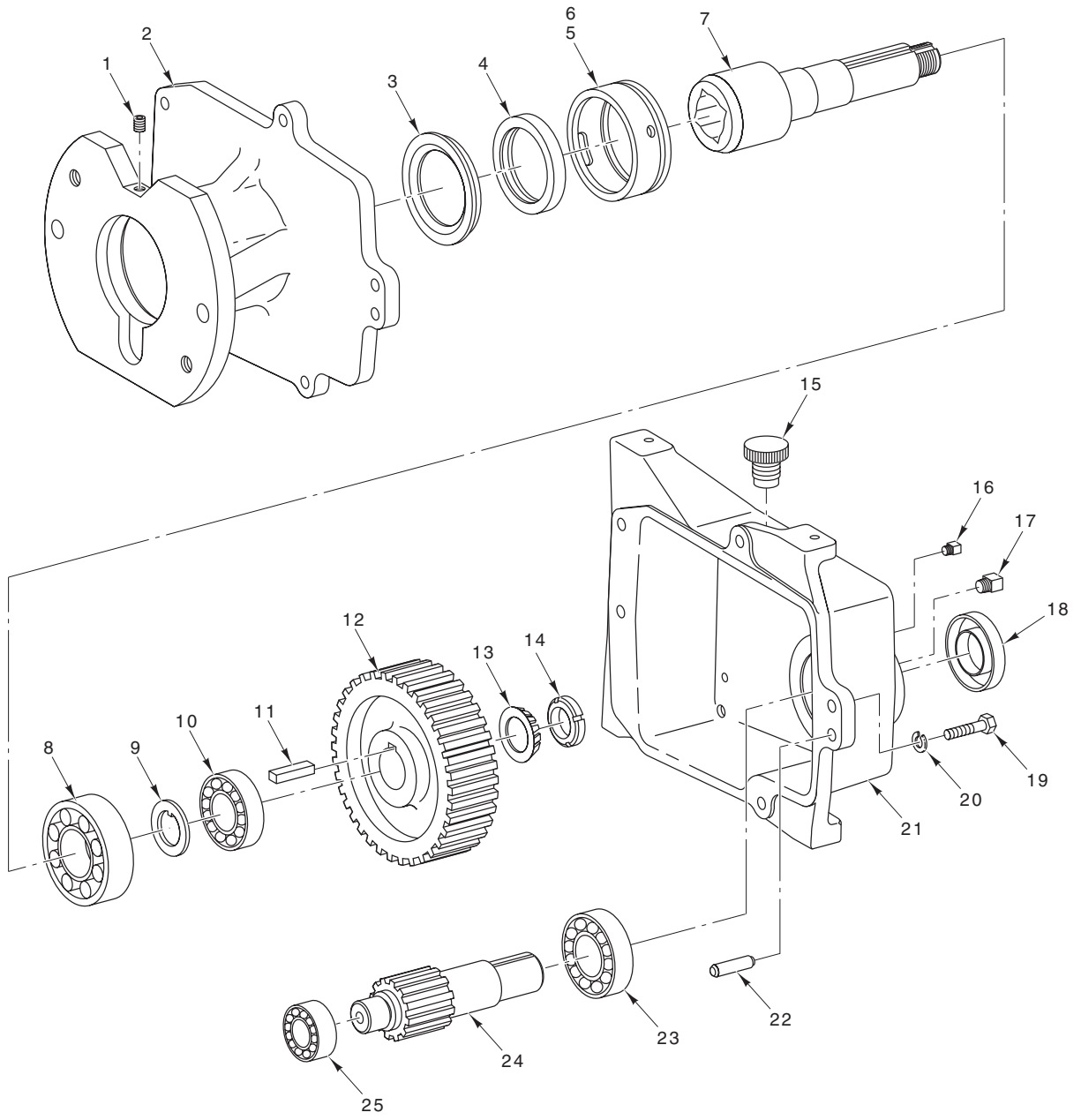

PL-56651

**GRIND TRANSMISSION
(PREVIOUS CONSTRUCTION)**

**GRIND TRANSMISSION
(PREVIOUS CONSTRUCTION)**

ILLUS. PL-56651	PART NO.	NAME OF PART	AMT.
1	SC-047-35	Set Screw $\frac{5}{16}$ -18 x $\frac{1}{2}$ Hdls., Cup Pt.	1
2	00-186627	Hub – Attachment	1
3	00-105196	Seal – Outer Conveyor	1
4	00-108591	Seal – Square Drive Shaft	1
5	00-186655	Retainer – Seal	1
6	00-067500-00052	O-Ring	1
7	00-186635	Shaft – Grind Worm Drive	1
8	BR-002-28	Roller Bearing – Cone & Cup Assy. (1.625 x 3.25)	1
9	WL-017-07	Lockwasher – Bearing Lock Nut	1
10	BR-002-20	Roller Bearing – Cone & Cup Assy. (1.375 x 2.56)	1
11	00-012430-00210	Key $\frac{5}{16}$ x $\frac{5}{16}$ x $1\frac{3}{8}$	1
12	00-186642	Gear (57T)	1
13	NS-034-07	Lock Nut – Bearing	1
14	WS-031-36	Washer	1
15	00-108963-00002	Plug – Oil Fill	1
16	FP-028-42	Plug – Pipe $\frac{1}{8}$	1
17	FP-028-38	Plug – Pipe $\frac{3}{8}$	1
18	00-186657	Seal – Oil	1
19	SC-062-22	Cap Screw $\frac{3}{8}$ -16 x $1\frac{1}{4}$ Hex Hd.	5
20	WL-006-28	Lockwasher $\frac{3}{8}$ Helical (SST)	5
21	00-186626	Case – Gear	1
22	00-508199	Dowel Pin	2
23	BB-007-21	Ball Bearing SKF 6207BE	1
24	00-186636	Shaft – Pinion (18T)	1
25	BB-018-33	Ball Bearing – Fafnir #205K	1

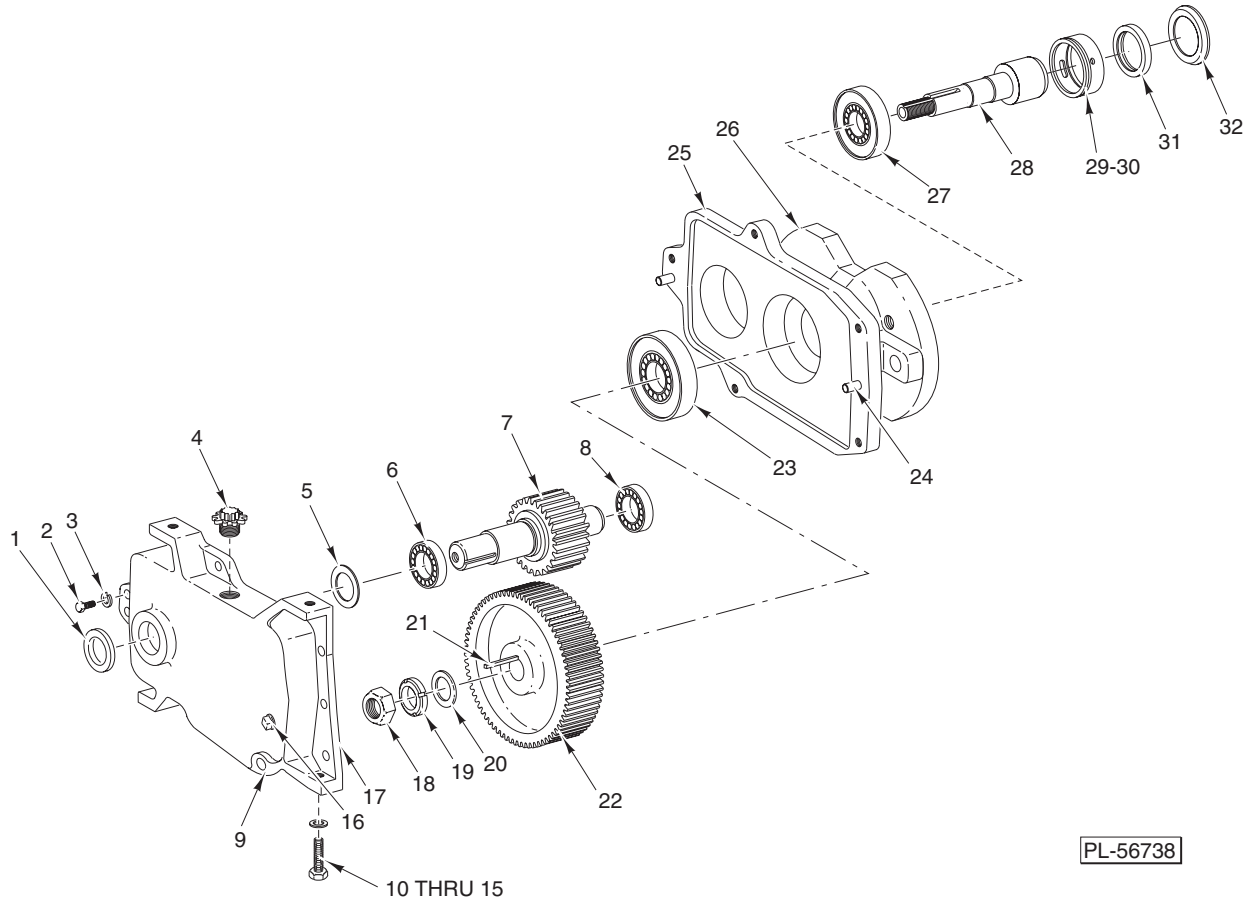

PL-56738

**GRIND TRANSMISSION
(CURRENT CONSTRUCTION)**

**GRIND TRANSMISSION
(CURRENT CONSTRUCTION)**

ILLUS. PL-56738	PART NO.	NAME OF PART	AMT.
1	00-186657	Seal – Oil	1
2	SC-062-22	Cap Screw $\frac{3}{8}$ -16 x $1\frac{1}{4}$ Hex Hd.	5
3	WL-006-28	Lockwasher $\frac{3}{8}$ Medium	5
4	00-108963-00002	Plug – Oil Fill	1
5	SL-003-11	Spring – Loading N.D. 72	1
6	BB-007-21	Ball Bearing – N.D. 3207	1
7	00-477940	Shaft – Pinion (18T)	1
8	BB-018-33	Ball Bearing Fahnir #205KF	1
9	FP-028-38	Plug – Pipe $\frac{3}{8}$	1
10	SC-062-22	Cap Screw $\frac{3}{8}$ -16 x $1\frac{1}{4}$ Hex Hd.	2
11	WL-006-28	Lockwasher $\frac{3}{8}$ Medium	2
12	00-186646-00001	Shim (0.120 Thk.)	AR
13	00-186646-00002	Shim (0.060 Thk.)	AR
14	00-186646-00003	Shim (0.030 Thk.)	AR
15	00-186646-00004	Shim (0.018 Thk.)	AR
16	FP-028-42	Plug – Pipe $\frac{1}{8}$	1
17	00-873483-00002	Case – Gear	1
18	NS-034-07	Lock Nut N.D. #N-06	1
19	WS-031-36	Washer	1
20	WL-017-07	Lockwasher – Bearing Lock Nut	1
21	00-012430-00215	Key $\frac{5}{16}$ X $\frac{5}{16}$ X $1\frac{1}{2}$	1
22	00-477939	Gear (57T)	1
23	BR-002-20	Bearing Assy. – Roller 1.37 x 2.56	1
24	00-508199	Pin Dowel (Mach.)	2
25	00-477946-00002	Hub – Attachment	1
26	SC-047-35	Set Screw $\frac{5}{16}$ -18 x $\frac{1}{2}$ Hdls., Cup Pt.	1
27	BR-002-28	Bearing Assy. – Roller 1.62 x 3.25	1
28	00-186635	Shaft – Grind Worm Drive	1
29	00-186655	Retainer – Seal	1
30	00-067500-00052	O-Ring (Rubber)	1
31	00-108591	Seal – Sq. Drive Shaft	1
32	00-105196	Seal – Outer Conveyor	1
	00-875585	Transmission Assy.	1

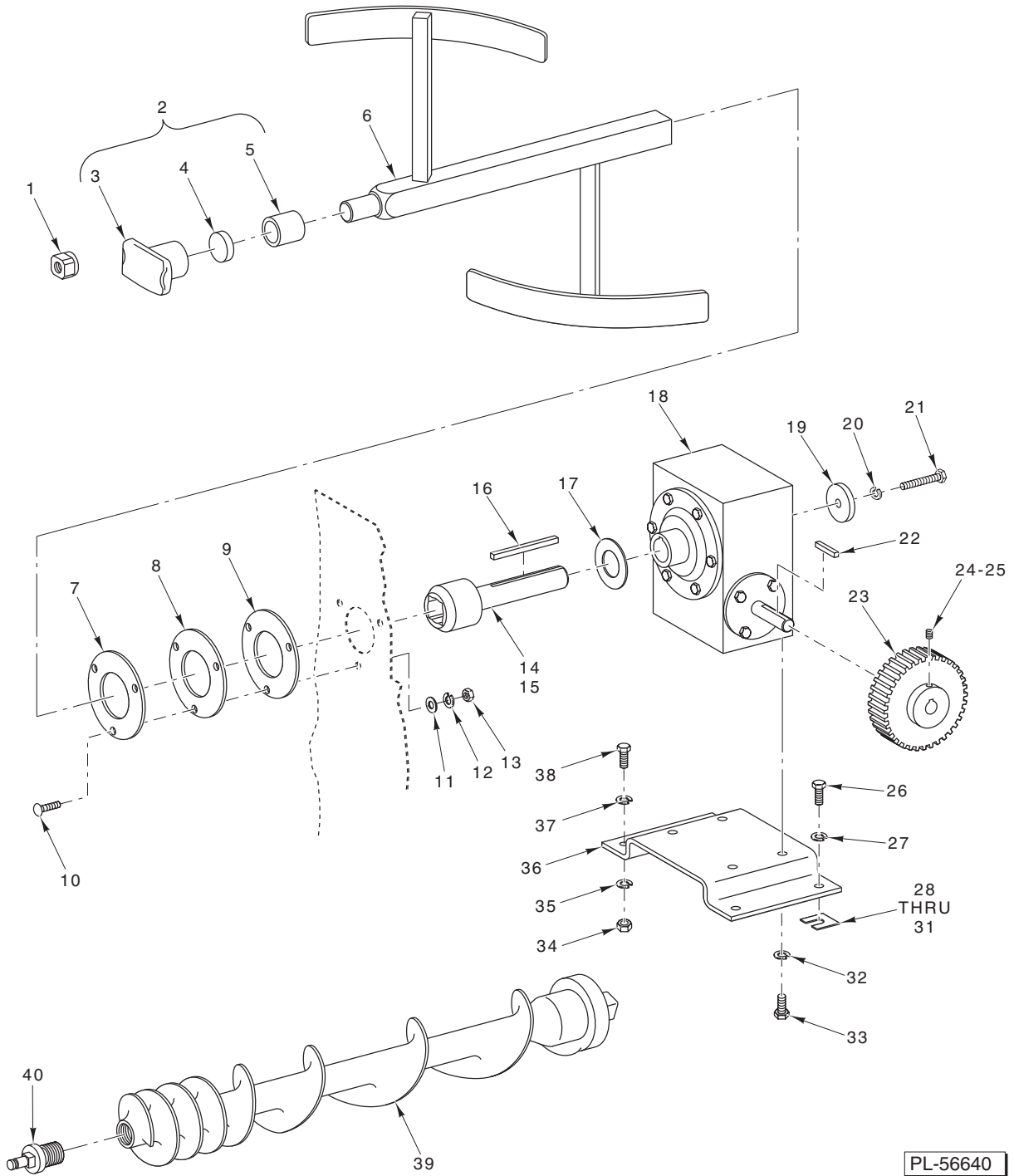

PL-56640

GRIND CONVEYOR AND MIXING ARM/TRANSMISSION

GRIND CONVEYOR AND MIXING ARM/TRANSMISSION

ILLUS. PL-56640	PART NO.	NAME OF PART	AMT.
1	NS-048-57	Nut $\frac{5}{8}$ -11 Flanged	2
2	00-186728	Pilot Bushing Assy.	1
3	00-186629	Bushing	1
4	00-186660	Washer – Thrust	1
5	00-186659	Bearing – Pilot Bushing	1
6	00-186718	Arm – Mixing	1
7	00-186649	Washer – Backing	1
8	00-186656	Seal – Mixing Arm Drive Shaft	1
9	00-186649	Washer – Backing	1
10	SC-094-20	Bolt $\frac{5}{16}$ -18 x 1 Sq. Nk. Rd. Hd.	3
11	WS-005-39	Washer (SST)	3
12	WL-006-23	Lockwasher $\frac{5}{16}$ Helical (SST)	3
13	NS-015-11	Nut $\frac{5}{16}$ -18 Hex	3
14	00-875578	Shaft – Mixing Arm Square Drive	1
15	00-186706	Plug	1
16	00-012430-00196	Key $\frac{1}{4}$ x $\frac{1}{4}$ x $4\frac{3}{4}$	1
17	00-186702	Washer – Shim	AR
18	00-186696	Gear Reducer	1
19	00-186703	Washer	1
20	WL-006-28	Lockwasher $\frac{3}{8}$ Helical (SST)	4
21	SC-062-22	Cap Screw $\frac{3}{8}$ -16 x $1\frac{1}{4}$ Hex Hd.	1
22	00-012430-00067	Key $\frac{3}{16}$ x $\frac{3}{16}$ x $1\frac{1}{2}$	1
23	00-186623-00001	Pulley – Driven (40T)	1
24	SC-088-46	Set Screw 10-24 x $\frac{3}{8}$ Soc. Hdls., Cup Pt.	2
25	00-520228	Adhesive – Loctite	AR
26	SC-062-22	Cap Screw $\frac{3}{8}$ -16 x $1\frac{1}{4}$ Hex Hd.	2
27	WL-006-28	Lockwasher $\frac{3}{8}$ Helical (SST)	2
28	00-186646-00001	Shim (0.120 In.)	AR
29	00-186646-00002	Shim (0.060 In.)	AR
30	00-186646-00003	Shim (0.030 In.)	AR
31	00-186646-00004	Shim (0.018 In.)	AR
32	WL-006-28	Lockwasher $\frac{3}{8}$ Helical (SST)	4
33	SC-118-12	Cap Screw $\frac{3}{8}$ -16 x $\frac{3}{4}$ Hex Hd.	4
34	NS-015-13	Nut $\frac{3}{8}$ -16 Hex (SST)	2
35	WL-006-28	Lockwasher $\frac{3}{8}$ Helical (SST)	2
36	00-293444	Plate – Mounting	1
37	WS-026-02	Washer (SST)	2
38	SC-066-22	Cap Screw $\frac{3}{8}$ -16 x $1\frac{1}{4}$ Hex Hd.	2
39	00-186641	Conveyor Screw Assy. (Incls. Item 41)	1
40	00-110576	Plate – Stud	1

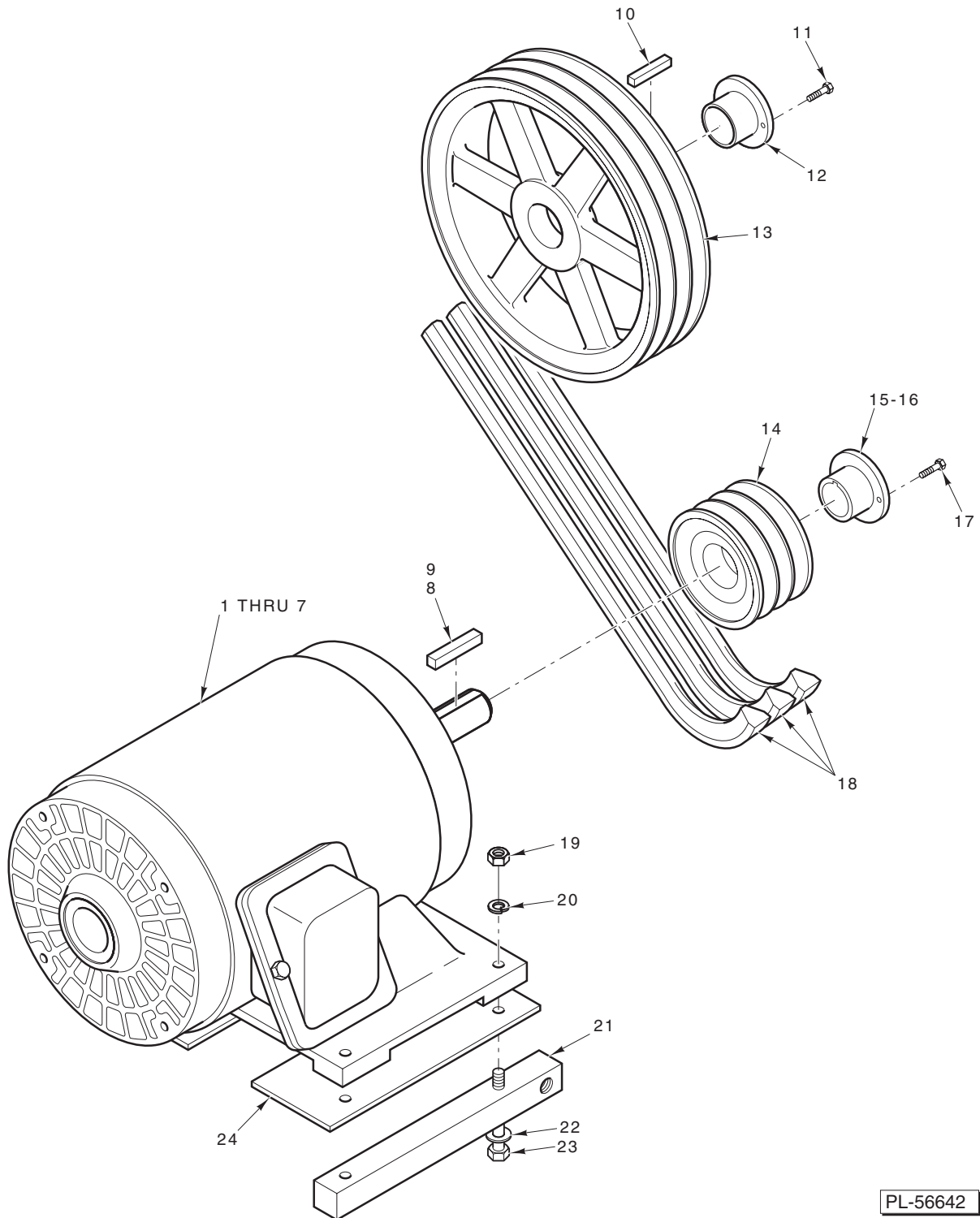

PL-56642

GRIND MOTOR/DRIVE UNIT

GRIND MOTOR/DRIVE UNIT

ILLUS.	PART NO.	NAME OF PART	AMT.
	PL-56642		
1	00-435696-00003	Motor Assy. – Drive (208 V., 60 Hz., 3 Ph., 5 Hp.)	1
2	00-435696-00004	Motor Assy. – Drive (240/480 V., 60 Hz., 3 Ph., 5 Hp.)	1
3	00-435697-00003	Motor Assy. – Drive (208 V., 60 Hz., 3 Ph., 7.5 Hp.)	1
4	00-435697-00004	Motor Assy. – Drive (240/480 V., 60 Hz., 3 Ph., 7.5 Hp.)	1
5	00-293210-00001	Motor Assy. – Drive (240/480 V., 50 Hz., 3 Ph., 7.5 Hp.)	1
6	00-435698-00002	Motor Assy. – Drive (208-240 V., 60 Hz., 1 Ph., 5 Hp.)	1
7	FE-023-47	Connector – Cable	1
8	00-012430-00106	Key $\frac{3}{16}$ X $\frac{5}{16}$ 1 $\frac{1}{4}$	1
9	00-012430-00163	Key $\frac{1}{4}$ X $\frac{1}{4}$ X 1 $\frac{3}{4}$ (5 Hp.)	1
10	00-012430-00178	Key $\frac{1}{4}$ X $\frac{1}{4}$ X 1 $\frac{1}{2}$	1
11	SC-118-19	Cap Screw $\frac{1}{4}$ -20 X $\frac{3}{4}$ Hex Hd.	2
12	00-479615-00002	Hub	1
13	00-479615-00001	Pulley – Transmission	1
14	00-479613-00001	Pulley – Grind Motor	1
15	00-479613-00002	Hub (7.5 Hp.)	1
16	00-479613-00003	Hub (5 Hp.)	1
17	SC-118-19	Cap Screw $\frac{1}{4}$ -20 X $\frac{3}{4}$ Hex Hd.	2
18	BV-013-37	V – Belt (BX Cross Section)	3
19	NS-015-13	Nut $\frac{3}{8}$ -16 Hex (SST)	4
20	WL-006-28	Lockwasher $\frac{3}{8}$ Helical (SST)	4
21	00-186694	Support – Motor Mount	2
22	WS-018-04	Washer	4
23	SC-097-31	Cap Screw $\frac{3}{8}$ -16 X 2 $\frac{1}{2}$ Hex Hd.	4
24	00-186682	Cover – Motor Plate	1
	00-875243	Conversion Kit – Belt/Pulley Assy. (60 Hz., 7.5 Hp.) (Incls. Items 12 thru 15, 18, & FP-028-38)	1
	00-875244	Conversion Kit – Belt/Pulley Assy. (60 Hz., 5 Hp.) (Incls. Items 12, 13, 14, 16, 18, & FP-028-38)	1
	00-875245	Conversion Kit – Belt/Pulley Assy. (50 Hz., 7.5 Hp.) (Incls. Items 12 thru 15, 18, & FP-028-38)	1

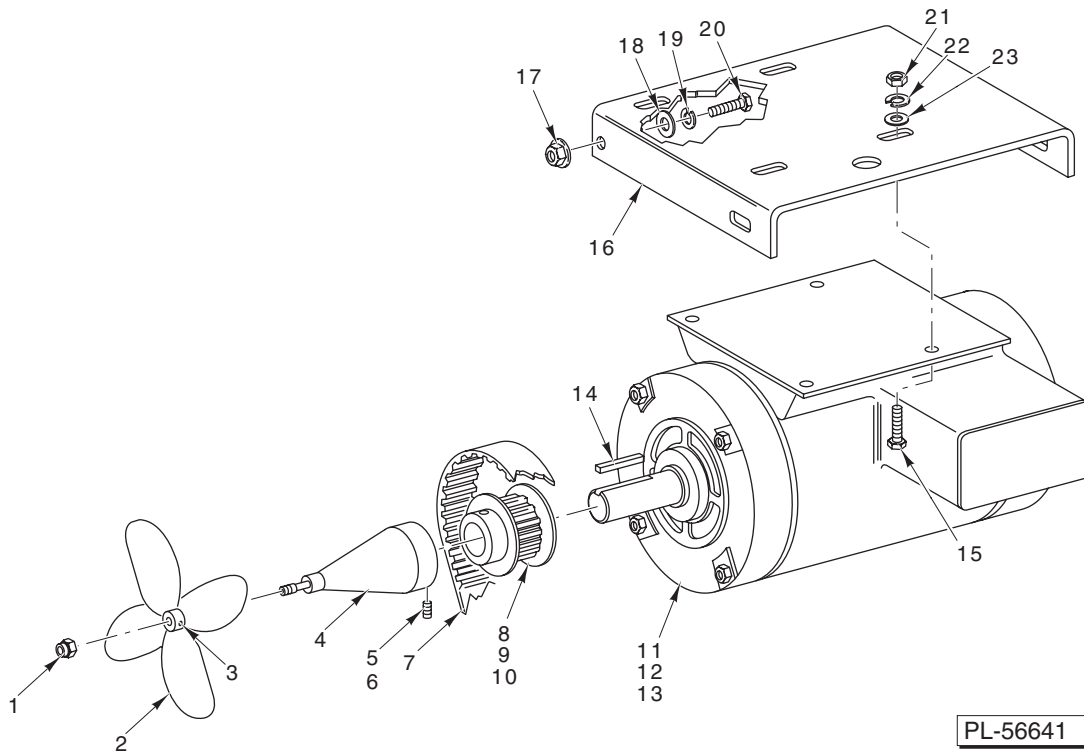

MIX ARM MOTOR/VENTILATING UNIT

MIX ARM MOTOR/VENTILATING UNIT

ILLUS. PL-56641	PART NO.	NAME OF PART	AMT.
1	NS-031-20	Stop Nut 1/4-20 Hex	1
2	00-186786	Blade – Fan	1
3	SC-075-30	Set Screw 8-32 x 3/16 Hdls., Cup Pt.	1
4	00-274696	Shaft – Fan Adapter	1
5	SC-117-84	Set Screw 1/4-20 x 5/16 Hex Hdls., Cup Pt. (SST)	1
6	00-520228	Adhesive – Loctite	AR
7	00-186714	Belt – Flexa-Gear	1
8	00-186622	Pulley – Driver (16T) (60 Hz.)	1
9	00-292996	Pulley – Driver (19T) (50 Hz.)	1
10	SC-075-30	Set Screw 8-32 x 3/16 Hex Hdls., Cup Pt.	1
11	00-435805-00002	Motor Assy. (208-240/480 V., 60 Hz., 3 Ph., 1 Hp.)	1
12	00-435806-00002	Motor Assy. (208-240 V., 60 Hz., 1 Ph., 1 Hp.)	1
13	00-293209-00001	Motor Assy. (240/480 V., 50 Hz., 3 Ph., 1 Hp.)	1
14	00-012430-00091	Key 3/16 x 3/16 x 1 3/8	1
15	SC-037-85	Cap Screw 5/16-18 x 1 Hex Hd.	4
16	00-186689	Bracket – Upper Motor Mounting	1
17	NS-038-10	Nut – Special Lock 3/8-16	4
18	WS-018-04	Washer	4
19	WL-006-28	Lockwasher 3/8 Helical	4
20	SC-041-31	Cap Screw 3/8-16 x 1 1/4 Hex Hd.	4
21	NS-013-14	Nut 5/16-18 Hex	4
22	WL-006-23	Lockwasher 5/16 Helical (SST)	4
23	WS-005-39	Washer	8

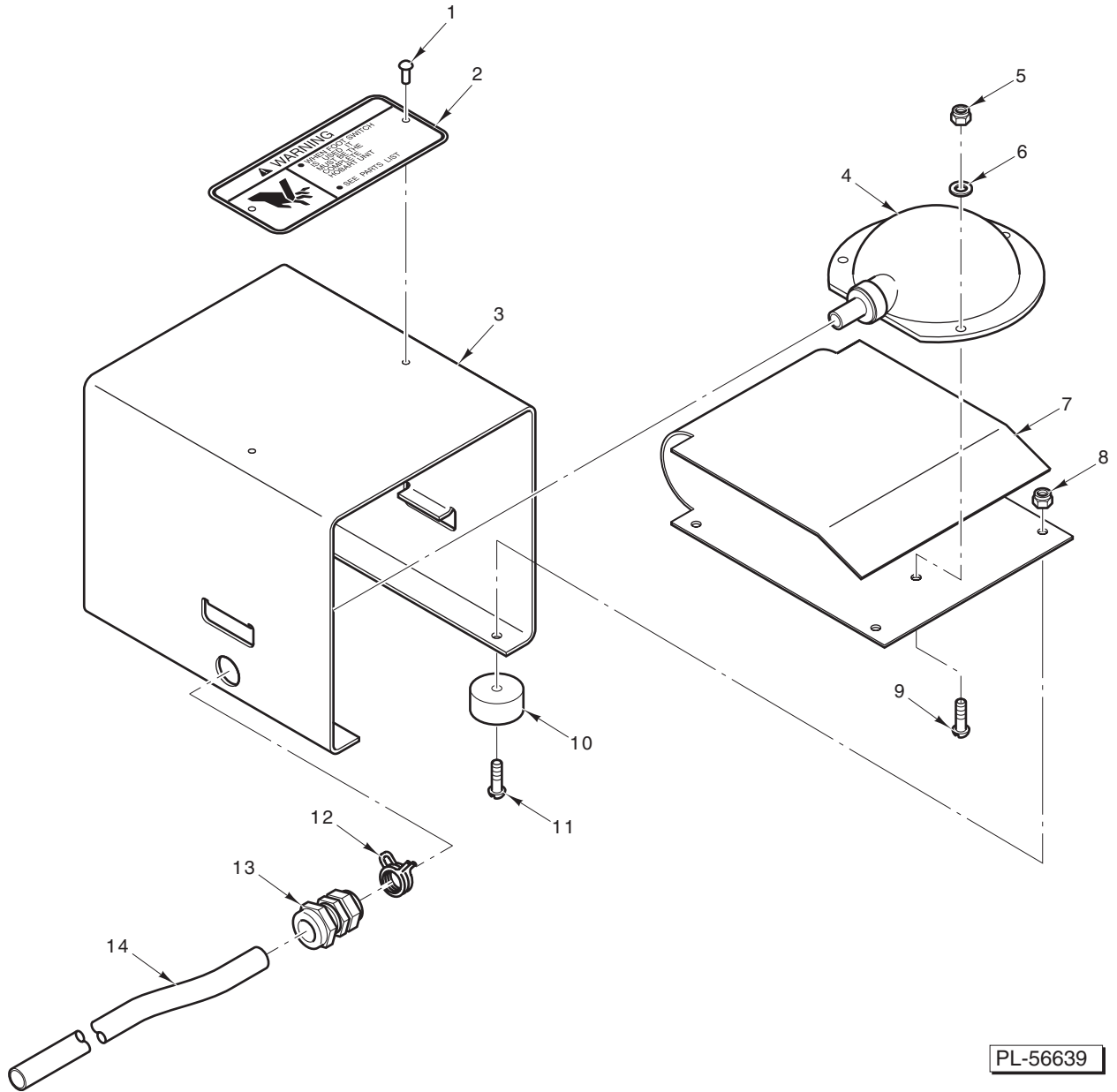

PL-56639

FOOT SWITCH

FOOT SWITCH

ILLUS.	PART NO.	NAME OF PART	AMT.
PL-56639			
1	00-123702	Stud – Weld	2
2	00-438131-00083	Plate – Warning	1
3	00-873544	Cover – Foot Switch	1
4	00-087711-214-1	Switch – Actuator	1
5	NS-031-08	Stop Nut Special 8-32 (SST)	3
6	WS-023-44	Washer (SST)	3
7	00-873543	Switch – Foot Pedal	1
8	NS-031-08	Stop Nut Special 8-32 (SST)	4
9	SC-021-15	Mach. Screw 8-32 x 1/2 Slotted Rd. Hd. (SST)	3
10	00-019105-00002	Bumper	4
11	SC-021-89	Mach. Screw 8-32 x 5/8 Slotted Rd. Hd. (SST)	4
12	00-115747-00008	Clamp – Hose	2
13	FE-024-10	Strain Relief	1
14	00-292629	Tubing – Air	1
	00-873545	Foot Switch Assy. (Incls. Items 1 thru 14)	1

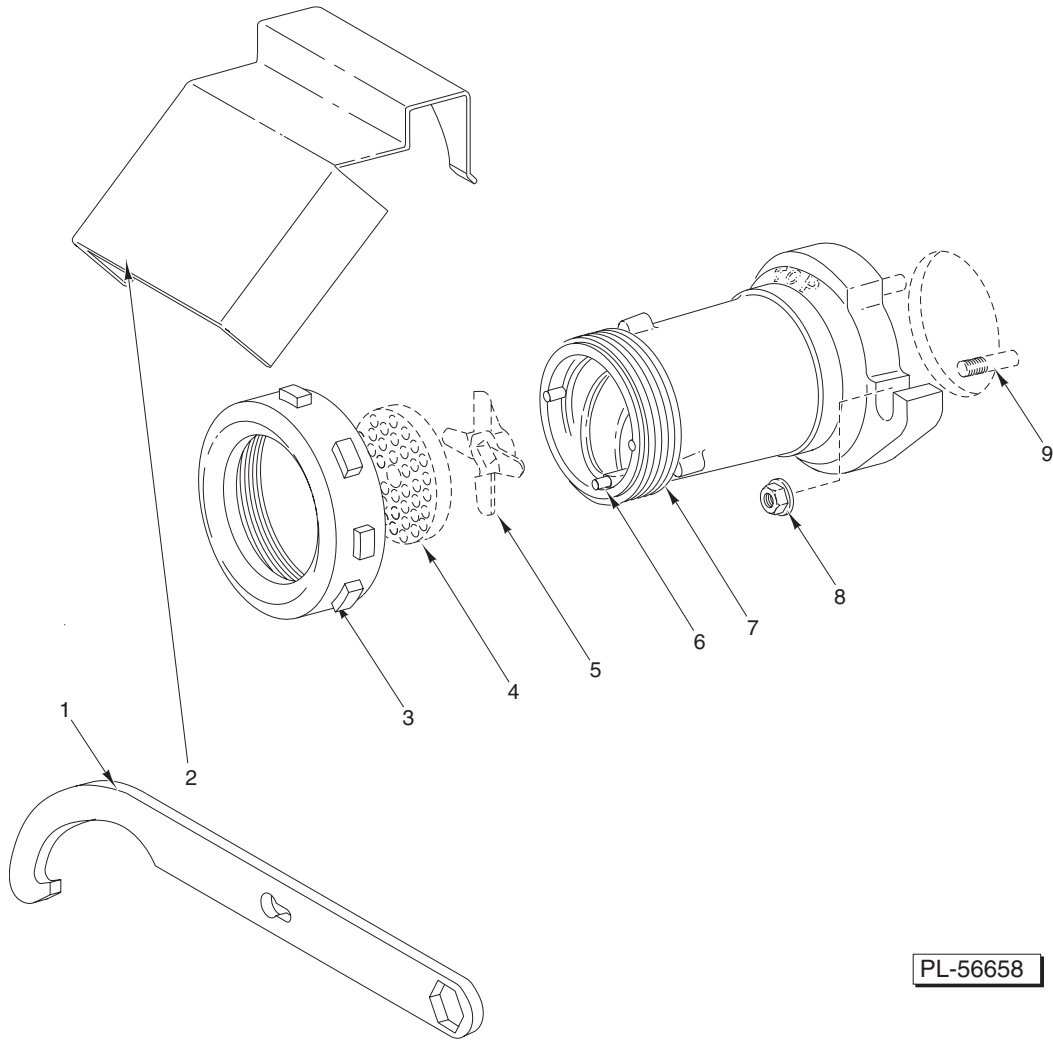

PL-56658

#32 GRINDER

#32 GRINDER

ILLUS.	PART NO.	NAME OF PART	AMT.
PL-56658			
1	00-873570	Wrench – Cylinder	1
2	00-875250	Meat Deflector (Packaged)	1
3	00-873697	Ring – Adjusting	3
4	*	Plate – Grinder	1
5	*	Knife – Grinder	1
6	00-105806	Pin – Plate	3
7	00-873720-00002	Cylinder #32 (Mach. SST)	1
8	NS-048-57	Nut $\frac{5}{8}$ -11 Flanged Hex	2
9	00-118266	Stud	2

* Sharp, High-Quality Knives And Plates Should Be Purchased Or Rented For This Grinder.

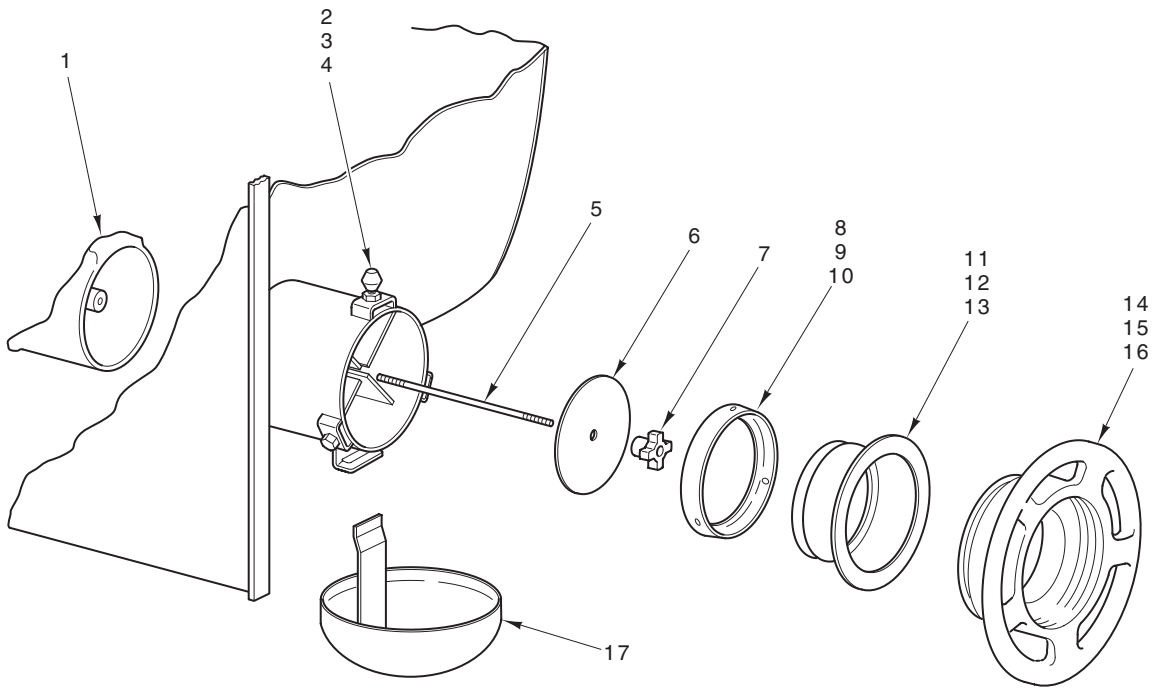

PL-56650

SIDE FEED

SIDE FEED

ILLUS.	PART NO.	NAME OF PART	AMT.
PL-56650			
1	00-186754	Plug – Side Feed Hopper	1
2	00-108197-00006	Thumb Screw (2 In. Lg.)	3
3	00-108197-00007	Thumb Screw (1 ⁷ / ₁₆ In. Lg.)	3
4	00-108197-00008	Thumb Screw (2 ⁹ / ₁₆ In. Lg.)	3
5	00-186755	Rod – Tie	1
6	00-107237	Cap – Hopper Feed	1
7	00-292420	Knob Assy.	1
8	00-086111	Retainer – Adapter (#56 Size)	1
9	00-082154	Retainer – Adapter (#52 Size)	1
10	00-082153	Retainer – Adapter (#32 Size)	1
11	00-086110	Adapter (#56 Size)	1
12	00-082149	Adapter (#52 Size)	1
13	00-082146	Adapter (#32 Size)	1
14	00-080879-00002	Ring – Adapter Adj. (For 4352, 4046, & 4146 “Stub Thd.”) (Packaged)	1
15	00-081374-00002	Ring – Adapter Adj. (For 52-46 “Stub Thd.”) (Packaged)	1
16	00-109738-00001	Ring – Adapter Adj. (For 4056, 4156, & 4356 “Stub Thd.”) (Packaged)	1
17	00-295109	Dripping Cup Assy.	1
	00-186885	Hopper Feed Plug Assy. (Incls. Items 1 & 5)	1
	00-109369-00002	Adapter Assy. (#56 Size) (For Non-Hobart Choppers) (Incls. Items 3, 8, & 11)	1
	00-109370-00002	Adapter Assy. (#52 Size) (For Non-Hobart Choppers) (Incls. Items 2, 9, & 12)	1
	00-109371-00002	Adapter Assy. (#32 Size) (For Non-Hobart Choppers) (Incls. Items 4, 10, & 13)	1



Online Parts Catalog

Note: It is helpful, but not essential to know the ML (Material List) Number of the equipment for which a part is needed

How Do I Find An ML Number?

The ML Number is found on the machine dataplate. The dataplate resembles the sample below, and is generally located on the back or side of a machine.

HOBART CORPORATION		MODEL	ML	
COMMERCIAL DISHWASHER TROY, OHIO				
LISTED 756A	UL	SERIAL NO.		
C	US	VOLTS	DATE CODE:	
NSF		HZ	PH	AMP
749901 MADE IN U.S.A.				

- Section 1 – If Equipment ML Number is known
- Section 2 – If Equipment ML Number is not known



PRODUCT DIRECTORY | Locate an Office | Warranty Registration | Career Opportunities

SERVICE | PARTS | INSTALLATIONS | WATER TREATMENT | MANUALS & SUPPORT | CONTRACTS & PMs



Hobart Service

We're there for you, anytime you need us. 24x7.



We're within 50 miles of 95% of our service customers. Only Hobart can provide such blanket coverage because we're the premier equipment manufacturer with nearly 200 offices and 1,700

Hobart Service News & Offers

Get \$25 Off Your Next Service Call!

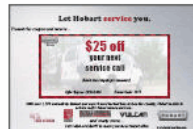

From *hobartservice.com* select PARTS



PRODUCT DIRECTORY | Locate an Office | Warranty Registration | Career Opportunities

SERVICE | PARTS | INSTALLATIONS | WATER TREATMENT | MANUALS & SUPPORT | CONTRACTS & PMs

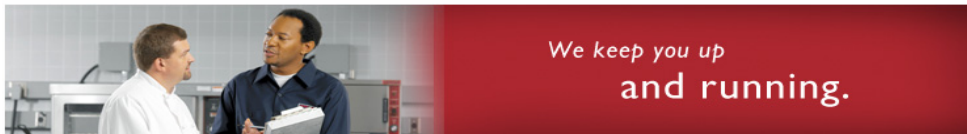

Hobart Service Home > Hobart National Parts and Accessories Program

National Parts and Accessories Program

Hobart SmartParts® System

The [Hobart SmartParts® System](#) is an interactive parts catalog system. By entering information from your equipment's data plate, you can be assured that you are accessing the



Not Sure How to Use SmartParts™?

It's easy! Just go through the [Hobart SmartParts™ Online Tutorial](#) and you'll be a parts pro in no time!

Hobart Parts QuickLinks

- ▶ [Hobart SmartParts® System](#)
- ▶ [Parts Catalogs](#)

Next select SMARTPARTS

Web Browser Pop-up blocker must be turned off for this site in order for SmartParts to operate

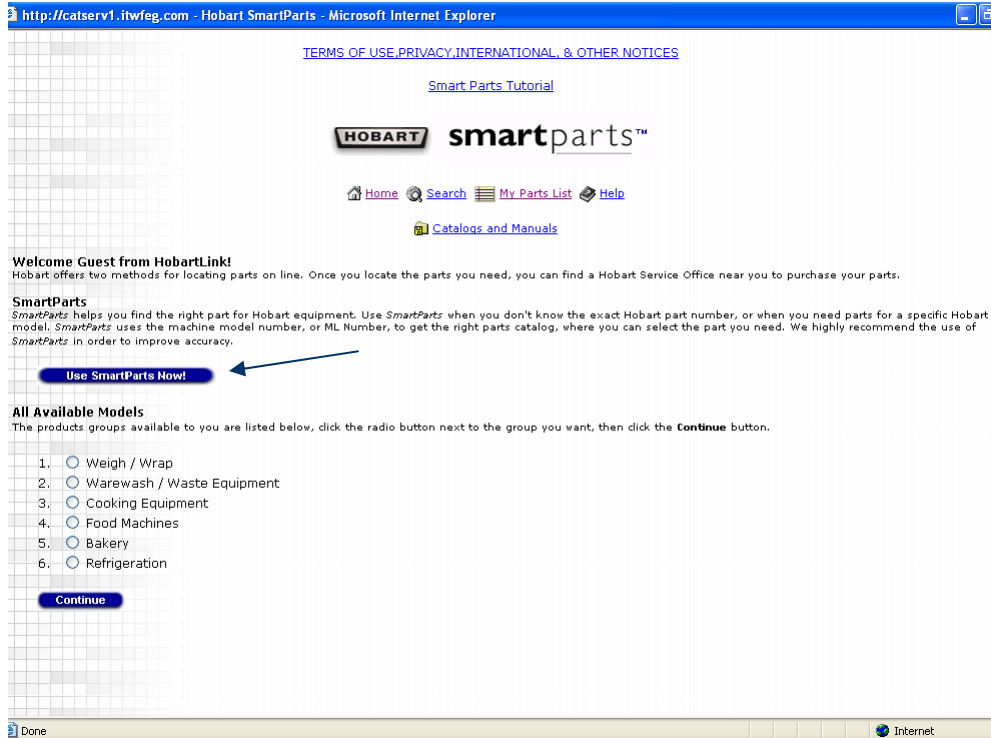

This is SmartParts home page

If the ML Number of the Equipment is known, select Use SmartParts Now

(We'll explain what to do if the ML number of the Equipment is not known in Section 2)

Section 1 – If Equipment ML Number is known

SmartParts

Enter Your ML Number

Enter your full or partial ML Number in the field provided, then click the **Search SmartParts!** button.

ML-

Enter the ML number and click on Search SmartParts

How Do I Find An ML Number?

The ML Number is found on the machine dataplate. The dataplate resembles the sample below, and is generally located on the back or side of a machine.

For this example, the part needed is a Water Pressure Gauge used on the LX 30 Undercounter Dishwasher

The ML number of this dishwasher is 104352

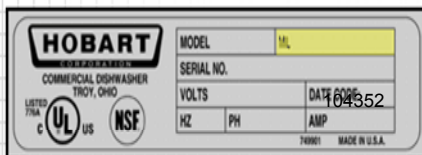

Hobart Parts Web

SmartParts

SmartParts results for **104352** (listed by product group):

Warewash / Waste Equipment

- LX Series Dishwashers (Includes ML numbers 104349, 104350, 104351, 104352, 130016, 130017, 130018, 130019)

Continue

Go Back

Click on the Radio button to select the Parts Catalog

Then click on Continue

Assemblies Available

LX Series Dishwashers (Includes ML numbers 104349, 104350, 104351, 104352, 104353, 104354, 104355, 104356, 110380, 110381, 130016, 130017, 130018, 130019)

Click the radio button next to the assembly you want, then click the **Continue** button.

Continue

Go Back

- BASE ASSEMBLY
- TANK ASSEMBLY
- DOOR ASSEMBLY
- ELECTRICAL CONTROL DRAWER (LX SERIES)
- ELECTRICAL CONTROL DRAWER (LXi SERIES)
- DISPLAY
- WASH ARM ASSEMBLY (LX18 SERIES)
- WASH ARM ASSEMBLY (LX30/40, LXG, LXi, & LXiG SERIES)
- WASH PIPE ASSEMBLY
- 50 HZ., 60 HZ. PUMP AND MOTOR ASSEMBLY (INGERSOLL OR CRANE)

The Water Pressure Gauge is on the Base Assembly

Select Base Assembly

Then click on Continue

Parts List

BASE ASSEMBLY

Select an appropriate figure size

Change To:

Different Assembly

Different Product

To add an item to your parts list, click the **Add** button next to the item. To see an exploded view, click on the view figure buttons.

View Figure: @ 25% @ 50% @ 75% @ 100% ←

Add	Item	Part No.	Part Description	Qty Used On Assembly
Add	1	00-328634	Track Assy. (RH)	1
Add	2	NS-015-01	Nut 1/4-20 Hex (SST)	8
Add	3	WL-006-17	Lockwasher 1/4 Medium	8

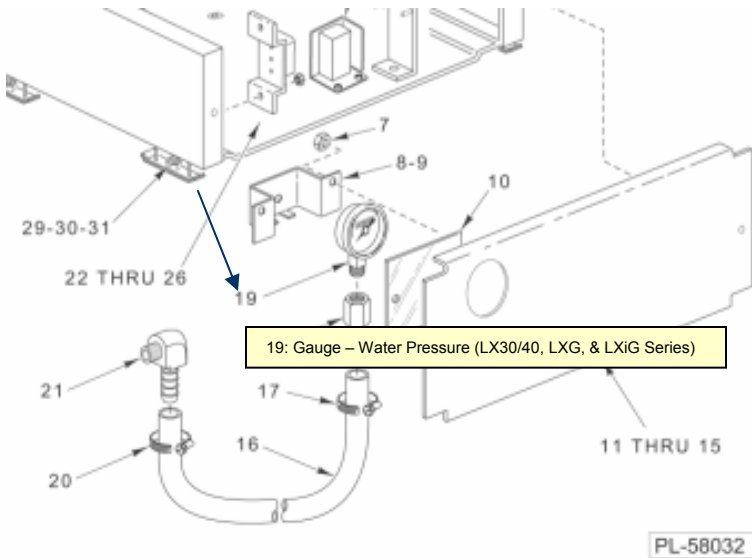

BASE ASSEMBLY

Locate the part needed (Water Pressure Gauge) on the drawing

Placing the cursor on the number will display the Description of the Part

Click on the number pointing to the part

Add	15	00-329267	Retainer - Screw #10	AR
Add	16	00-475060	Hose 1/4 x 12 Pressure Gauge to Fill Valve	1
Add	17	00-528501	Clamp - Hose #4	1
Add	18	FP-088-30	Fitting - Hose Barb (LX30/40, LXG, & LXi Series)	1
Add	19	00-918429	Gauge - Water Pressure (LX30/40, LXG, LXi, & LXiG Series)	1
Add	20	00-528501	Clamp - Hose #4	1
Add	21	FP-088-29	Fitting - Hose 1/4 Barb x 1/8-27 NPTM	1
Add	22	SC-018-24	Mach. Screw 6-32 x 3/4 Phil. Pan Hd.	2
Add	23	00-918385	Block - Terminal (5 Pole) (Current Construction)	1
Add	24	00-918339	Bracket - Terminal Block (Current Construction)	1
Add	25	NS-031-50	Stop Nut 6-32 Hex (SST)	2
Add	26	NS-031-16	Stop Nut 10-24 Hex Elastic (SST)	2
Add	27	00-475299-00001	Connector Assy. (Previous Construction)	1
Add	28	00-473138	Bracket - Terminal Block (Previous Construction)	1
Add	29	00-241857	Foot - Leveling	4
Add	30	00-329284	Spacer - Leveling Foot (LX18 Series)	4

- *Selecting the part on the figure causes the part to be highlighted on the parts list*
- *Click on the Add button to add the part to the shopping cart*
- *You can add more parts or change the quantity of the parts already in the cart*
- *When finished, click on the Confirm Parts Selected and then on Print Parts List if you want to print*

Parts Selected

Items Listed for Guest

Add More Items From:

There is 1 item in your parts list:

Delete	Qty. Req.	Part No.	Part Description	Parts List
<input type="button" value="Delete"/>	<input type="text" value="1"/>	00-918429	Gauge - Water Pressure (LX30/40, LXG, LXi, & LXiG Series)	BASE ASSEMBLY

Use SMARTPARTS Now

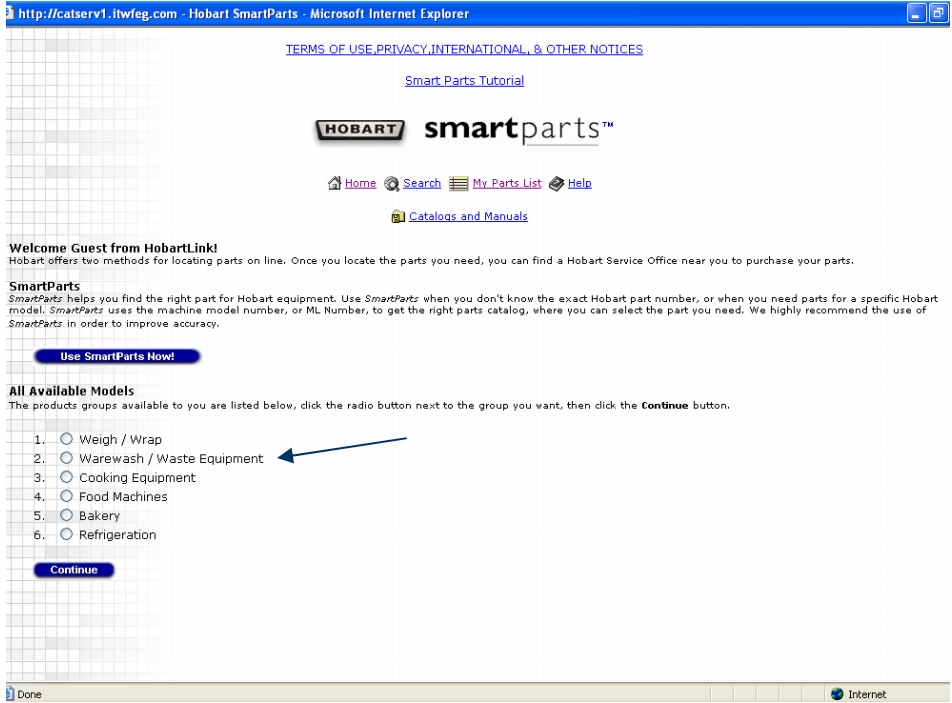

This (again) is SmartParts home page

For this example, the part needed is a Water Pressure Gauge used on the LX 30 Undercounter Dishwasher

If the ML Number of the Equipment is not known, click on the Radio button to select Warewash / Waste Equipment

Then click on Continue

(Go to Section 1 if you do know the ML number of the Equipment)

Section 2 – If Equipment ML Number is not known

Products Available

Warewash / Waste Equipment

Click the radio button next to the product you want, then click the **Continue** button.

Continue **Go Back**

- 1. Door Type Dishwasher
- 2. Booster
- 3. Conveyor Type Dishwasher (C-LINE)
- 4. Flight Type Dishwasher
- 5. Miscellaneous Warewash
- 6. UnderCounter Dishwasher (indicated by a blue arrow)
- 7. Waste Equipment

Continue **Go Back**

Click on the Radio button to select UnderCounter Dishwasher

Then click on Continue

Parts Catalogs

UnderCounter Dishwasher

Click the radio button next to the catalog you want, then click the **Continue** button.

Continue **Go Back**

- LX Series Dishwashers (Includes ML numbers 104349, 104350, 104351, 104352, 104353, 104354, 104355, 104356, 110380, 110381, 130016, 130017, 130018, 130019)
- WM Series Dishwashers
- Dishwasher Motor Book (Includes the following Motor Spec /ML numbers - 9257, 6661, 8115, 17829, 18897, 18751, 18931, 18930, 18932, 31219, 31220, 31221, 18491, 17350, 9801, 18603)
- SR24 Series Dishwasher (SR24C - ML-130021, SR24H - ML-130022)
- Fast Food Warewashers

Continue **Go Back**

Click on the Radio button to select LX Series Dishwashers

Then click on Continue

Assemblies Available

LX Series Dishwashers (Includes ML numbers 104349, 104350, 104351, 104352, 104353, 104354, 104355, 104356, 110380, 110381, 130016, 130017, 130018, 130019)

Click the radio button next to the assembly you want, then click the **Continue** button.

Continue **Go Back**

- BASE ASSEMBLY
- TANK ASSEMBLY
- DOOR ASSEMBLY
- ELECTRICAL COMPONENTS(LX SERIES)
- ELECTRICAL COMPONENTS (LXi SERIES)
- DISPLAY
- WASH AND RINSE ARM ASSEMBLY(lx30/40, lxxg, lxi, & lxiig SERIES)(PREV. CONSTR.)
- WASH AND RINSE ARM ASSEMBLY(lx30/40, lxxg, lxi, & lxiig SERIES)(CURRENT CONSTR.)
- WASH ARM ASSEMBLY(LX18 SERIES)
- WASH PIPE ASSEMBLY (PREVIOUS CONSTRUCTION)
- WASH PIPE ASSEMBLY (CURRENT CONSTRUCTION)

The Water Pressure Gauge is on the Base Assembly

Select Base Assembly

Then click on Continue

Parts List

BASE ASSEMBLY

Select an appropriate figure size

Change To:

Different Assembly

Different Product

To add an item to your parts list, click the **Add** button next to the item. To see an exploded view, click on the view figure buttons.

View Figure: @ 25% @ 50% @ 75% @ 100% ←

Add	Item	Part No.	Part Description	Qty Used On Assembly
Add	1	00-328634	Track Assy. (RH)	1
Add	2	NS-015-01	Nut 1/4-20 Hex (SST)	8
Add	3	WL-006-17	Lockwasher 1/4 Medium	8

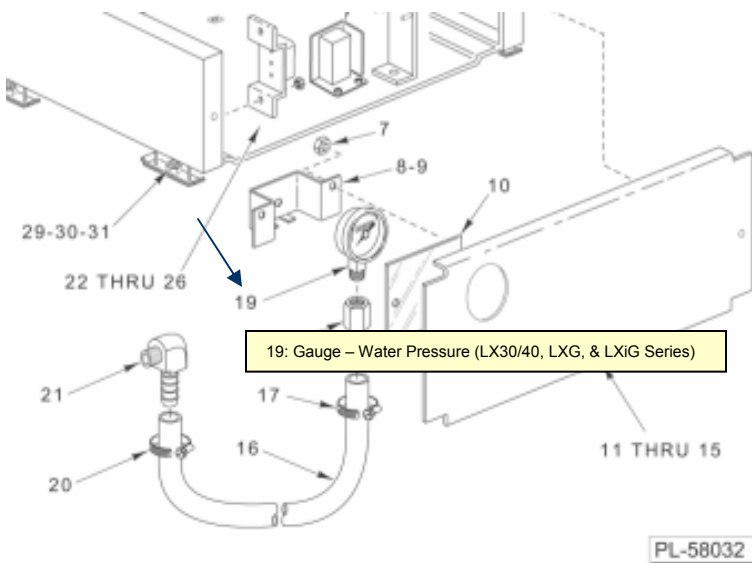

BASE ASSEMBLY

Locate the part needed (Water Pressure Gauge) on the drawing

Placing the cursor on the number will display the Description of the Part

Click on the number pointing to the part

Add	15	00-329267	Retainer - Screw #10	AR
Add	16	00-475060	Hose 1/4 x 12 Pressure Gauge to Fill Valve	1
Add	17	00-528501	Clamp - Hose #4	1
Add	18	FP-088-30	Fitting - Hose Barb (LX30/40, LXG, & LXI Series)	1
Add	19	00-918429	Gauge - Water Pressure (LX30/40, LXG, LXI, & LXIG Series)	1
Add	20	00-528501	Clamp - Hose #4	1
Add	21	FP-088-29	Fitting - Hose 1/4 Barb x 1/8-27 NPTM	1
Add	22	SC-018-24	Mach. Screw 6-32 x 3/4 Phil. Pan Hd.	2
Add	23	00-918385	Block - Terminal (5 Pole) (Current Construction)	1
Add	24	00-918339	Bracket - Terminal Block (Current Construction)	1
Add	25	NS-031-50	Stop Nut 6-32 Hex (SST)	2
Add	26	NS-031-16	Stop Nut 10-24 Hex Elastic (SST)	2
Add	27	00-475299-00001	Connector Assy. (Previous Construction)	1
Add	28	00-473138	Bracket - Terminal Block (Previous Construction)	1
Add	29	00-241857	Foot - Leveling	4
Add	30	00-329284	Spacer - Leveling Foot (LX18 Series)	4

- *Selecting the part on the figure causes the part to be highlighted on the parts list*
- *Click on the Add button to add the part to the shopping cart*
- *You can add more parts or change the quantity of the parts already in the cart*
- *When finished, click on the Confirm Parts Selected and then on Print Parts List if you want to print*

Parts Selected

Items Listed for Guest

Add More Items From:

Current Assembly

Different Assembly

Different Product

There is 1 item in your parts list:

Delete	Qty. Req.	Part No.	Part Description	Parts List
Delete	<input type="text" value="1"/>	00-918429	Gauge - Water Pressure (LX30/40, LXG, LXI, & LXIG Series)	BASE ASSEMBLY

Update Quantities

Confirm Parts Selected

Use **SMARTPARTS** Now



PRODUCT SERVICE DEPARTMENT

TROY, OH. 45374-0001

RECOMMENDED SPARE PARTS LIST

4246 MIXER/GRINDER

Qty	Part Number	Description
1	105196	Seal, Outer Conveyor
2	118266	Stud, Cylinder
2	NS-048-57	Nut, Cylinder
1	087711-214-1	Actuator, Air
1	087711-213-1	Switch, Air
1	875712	Tubing, Air
1	087713-94-2	Contactactor (208) (1 Con)
2	087711-268-1	Switch, Aux (1 Con)
1	088196-24-1	Relay, Overload (208) (1OL)
1	087711-266	Switch, Aux (2 Con)
1	087713-89-3	Contactactor (208) (2 Con)
1	088196-17-1	Relay, Overload (208) (2OL)
1	087711-322-3	Contact Block
1	087711-322-5	Contact Block