

12" Humidified Rotating & Non-Rotating Pizza/Pretzel Warmers

RETAIN THIS MANUAL FOR FUTURE REFERENCE.
UNIT MUST BE KEPT CLEAR OF COMBUSTIBLES AT ALL TIMES.



Models: 423PDW12D1, 423PDW12D2, 423PDW12D1P, 423PDW12D2P, 423PDW12D1S,
423PDW12D2S

Table of Contents

Owner's Information	3
Safety Warnings	4
Specifications	6
Control Panel	6
Operating Instructions	6
General Cleaning.....	8
Wiring Diagrams	10
Troubleshooting	11
Warranty	12

Owner's Information

Please complete this information and retain this manual for the life of the equipment. For warranty purposes, please fill out and retain this information. An example of the serial plate(s) for these units are included below for reference.

Model No. _____

Serial No. _____

Date of Purchase: _____

Serial Plate Example:



ITEM #: 423PDW12D1

MANUFACTURER MODEL #:

DESCRIPTION: ROTATING PIZZA WARMER 12", SINGLE DOOR

VOLTAGE: 120V • WATTAGE: 800W

AMPERAGE: 7.2A • FREQUENCY: 60Hz

SERIAL #:

WARNING! Improper installation, adjustment, alteration, service or maintenance can cause property damage, injury or death. Read the installation, operating, and maintenance instructions thoroughly before installing or servicing this equipment.

WARNING! Disconnect from electric supply before adjustment, alternation, service or maintenance.

WARNING! Minimum clearance from side and back of unit to combustible construction: 10" from sides and 10" from back. For use in noncombustible locations only.

WARNING! Commercial use only, not intended for household use.

WARNING! ELECTRICAL SHOCK HAZARD, do not immerse electrical components.

ServIt humidified Rotating and Non-rotating pizza/pretzel warmers are designed to keep foods at optimum serving temperatures without affecting quality, for hours at a time. Hold anything from hot pretzels, fresh pizza, nachos, hot dogs, and more, perfect for commercial environments such as convenience stores, self-service restaurants, and supermarkets.

All models include standard features such as LED lighting to effectively illuminate food product, and 3-sided merchandiser decal slots for effective merchandising. Controls are top mounted for convenient access and adjustment. They are built for tough front-of-house duty with rugged stainless-steel construction, heavy-duty hardware, and smart merchandising features to attract any customer.

On rotating models, the rotating racks will stop automatically when either the front or rear door is opened, making it ideal for front or back counter applications. On non-rotating models, the racks are fully adjustable on height to allow for various sizes of pre-packaged foods. All models come in either 1 or 2 door configurations for use on a back counter or the order line for impulse purchases and easy reloading from the operator side.

This manual provides the installation, safety, and operating instructions for Rotating and Non-rotating pizza/pretzel warmers. ServIt recommends all installation, operating, and safety instructions appearing in this manual be read prior to installation or operation of the unit.

SAFETY WARNINGS

ServIt Humidified Pizza/Pretzel Warmers are designed, built, and sold for commercial use and should be operated by trained personnel only. Clearly post all CAUTIONS, WARNINGS, and OPERATING INSTRUCTIONS near each unit to insure proper operation and to reduce the chance of personal injury and/or equipment damage.

WARNING: Do not store or use gasoline or other flammable vapors and liquids in the vicinity of this or any other appliance. Keep the area free and clear of combustible materials.

WARNING: Improper installation, adjustment, alteration, service, or maintenance can cause property damage, injury or death. Read the Installation, Operating and Maintenance Instructions thoroughly before installing or servicing this equipment.

CAUTION: These models are designed, built, and sold for commercial use only. If these models are positioned so the general public can use the equipment, make sure all cautions, warnings, and operating instructions are clearly posted near each unit so that anyone using the equipment can use it correctly and not injure themselves or the equipment.

CAUTION: Make sure food product has been heated to the proper food-safe temperature before placing in unit. Failure to heat food product properly may result in serious health risks. This unit is for holding preheated food product only.

CAUTION: Locate unit in an area that is convenient for use. The location should be level and strong enough to support the weight of the unit and contents.

ELECTRIC SHOCK HAZARD:

- Plug unit into a properly grounded electrical receptacle of the correct voltage, size, and plug configuration. If plug and receptacle do not match, contact a qualified electrician to determine and install proper voltage and size electrical receptacle.
- Installation must conform to all local electrical codes, and where applicable must be installed by a qualified electrician. Installation by unqualified personnel will void unit warranty and may lead to electric shock or burn, as well as damage to unit and/or its surroundings.
- Turn OFF power switch, unplug power cord/turn off power at circuit breaker, and allow unit to cool before performing any cleaning, adjustments, or maintenance.
- DO NOT submerge or saturate with water. Unit is not waterproof. Do not operate if unit has been submerged or saturated with water.
- Unit is not weatherproof. Locate unit indoors where ambient air temperature is a minimum of 70°F (21°C).
- Do not clean unit when it is energized or hot.
- Do not steam clean or use excessive water on the unit.
- This unit is not “jet-proof” construction. Do not use jetclean spray to clean this unit.
- Do not pull unit by power cord.
- Discontinue use if power cord is frayed or worn.
- Do not allow liquids to spill into the unit.
- This unit must be serviced by qualified personnel only. Service by unqualified personnel may lead to electric shock or burn.

FIRE HAZARD:

- Locate unit a minimum of 12" (25 mm) from combustible walls and materials. If safe distances are not maintained, discoloration or combustion could occur.
- Do not use harsh chemicals such as bleach (or cleaners containing bleach), oven cleaners, or flammable cleaning solutions to clean this unit.

BURN HAZARD:

- Some exterior surfaces on unit will get hot. Use caution when touching these areas.
- Use caution when opening doors. Hot air escapes when door is open.

SPECIFICATIONS

- Cordset configuration: 120V NEMA 5-15P, 3 Wire grounded cord
- If the supply cord is damaged, the manufacturer or an authorized service agent or a similarly qualified person must replace it to avoid a hazard or voiding the warranty:

Item #	Maximum Pizza Size	# of Doors	Includes Pretzel Rack	# of Shelves	Rotating	Voltage	Wattage
12" Pizza Warmers, Rotating							
423PDW12D1	12"	1	N	4	Y	120V	800W
423PDW12D2	12"	2	N	4	Y	120V	800W
12" Pizza/Pretzel Warmers, Rotating							
423PDW12D1P	12"	1	Y	4	Y	120V	800W
423PDW12D2P	12"	2	Y	4	Y	120V	800W
12" Pizza Warmers, Non-Rotating							
423PDW12D1S	N/A	1	N	4	N	120V	800W
423PDW12D2S	N/A	2	N	4	N	120V	800W

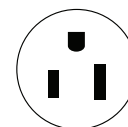

**NEMA
5-15P**

CONTROL PANEL

Letter	Description
A	Motor Switch
B	Light Switch
C	Heat Switch
D	Thermostat Dial
E	Heat Indicator Light
F	Temperature Display

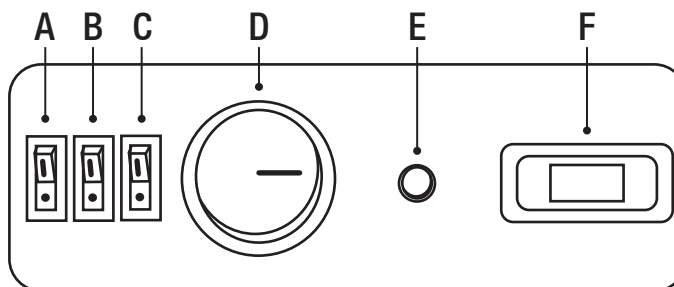

OPERATING INSTRUCTIONS

General Information:

- Always clean equipment thoroughly before first use. (See general cleaning instructions).
- Check rating label for your model designation and electrical rating.
- For best results, use stainless steel countertops.

WARNING: ELECTRICAL SHOCK HAZARD.

FAILURE TO FOLLOW THE INSTRUCTIONS IN THIS MANUAL COULD RESULT IN SERIOUS INJURY OR DEATH. Electrical Ground is required on this appliance. Do not modify the power supply cord plug. If it does not fit into the outlet, have the proper outlet installed by a qualified electrician. Do not use an extension cord with this appliance. Check with a qualified electrician if you are unsure as to whether the appliance is properly grounded.

General Operating Instructions:

- All foodservice equipment should be operated by trained personnel.
- Do not allow your customers to come in contact with any surface labeled CAUTION HOT.
- Where applicable: Never pour cold water into dry heated units.
- Never hold perishable food below 150°F (66°C).

Unboxing Instructions:

CAUTION: Pizza/pretzel warmer units are heavy and require two people to install.

1. Remove unit from carton and all packaging materials from the unit.
2. Remove the manual/information packet from the unit.
3. Place the unit in desired location.
4. **NOTE:** Place where the ambient air temperature is constant and a minimum of 70°F, and maximum 85°F. Avoid areas that are subject to active air movements or currents. Make sure the unit is located on a solid, level area and at a proper height for convenient use and also following health standards.
5. Locate an outlet of the correct plug and voltage type for the unit and plug in to.

Set-Up & Operating Instructions:

1. Ensure unit is properly plugged into adequate, grounded power outlet.
2. Turn the motor, light, and heat switches to the “I” (on) position.
3. If low levels of humidity are desired, fill the bottom mounted water pan approximately $\frac{3}{4}$ full with distilled water.
4. Set the thermostat to the desired temperature setting (see recommended settings).
5. Allow the unit 30 minutes to preheat to the desired temperature and humidity levels.

NOTE: A fully filled water pan can work continuously for 6-8 hours. The working time depends on different parameters, food type, frequency of door openings, as well as other factors. Failure to refill the water pan may result in damaged unit and/or voided product warranty.

NOTE: Different kinds of food will affect the cabinet temperature and humidity. The temperature on display is the cabinet temperature, not the food temperature. Follow all HACCP and safe food handling guidelines as dictated by Local, State and Federal governments.

Recommended Settings Chart:

Food Product	Temperature	Humidity	Max Holding Time (hours)
Rolls, Hard	160-185°F	No	4
Rolls, Soft	150-175°F	Yes	4
Pies, Desserts	160-185°F	Yes	3
Pizza, Thick Crust	170-185°F	Yes	2
Pizza, Thin Crust	165-180°F	Yes	2
Pretzels	135-150°F	Yes	3
Sandwiches, Wrapped	165-180°F	Yes	2
Chicken, Roasted	165-180°F	Yes	4
Chicken, Fried	165-180°F	No	4
Hot Dogs	160-185°F	Yes	3
Onion Rings	150-175°F	No	2
French Fries	135-150°F	No	2

NOTE: Temperature and humidity settings will require adjustment according to type and quantity of food, and number of times door(s) are opened during operation. These are recommendations based on ideal environments, and will need adjusted according to the usage environment.

GENERAL CLEANING

NOTES:

- Never clean any electrical unit by immersing it in water. Turn off unit and unplug before surface cleaning.
- Always clean equipment thoroughly before first use. Clean unit daily. Except where noted on charts: Use warm, soapy water. Mild cleansers and PLASTIC scouring pads may be used to remove baked-on food and water scale.
- Turn off electrical units before cleaning or servicing.

Instructions:

1. Follow general cleaning instructions (above).
2. Remove all food, remove all shelves (see specific instructions below).
3. Remove and drain water pan, wipe dry.
4. If Lime or Mineral build-up occurs, follow below guide on “removing lime and mineral deposits”.

NOTE: Cleaning solution or Delimer may be run through the water tank. Excess water is needed to flush out the cleaning solution through the line and tank until the water flows clear.

Cleaning and Installation of Rotary Shelves:

1. Turn off the unit and unplug it, allow the unit up to 30 minutes to cool down. **NOTE:** Opening the glass door(s) can help speed up the cooldown process.
2. Loosen top nut and bolt of the rotary shelf and remove.
3. Remove the rotary shelf from the heated cabinet and handwash with warm soapy water and air dry.
4. Place shelf back into unit, securing using the nut and bolt.

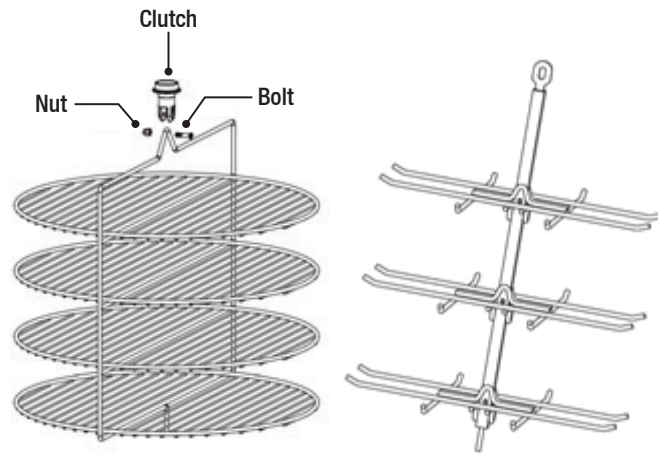

Cleaning and Installation of Non-Rotary Shelves:

1. Turn off the unit and unplug it, allow the unit up to 30 minutes to cool down. **NOTE:** Opening the glass door(s) can help speed up the cooldown process.
2. Lift the shelf from the clips.
3. Remove the shelves from the heated cabinet and handwash with warm soapy water and air dry.
4. Place shelves back into unit on clips.

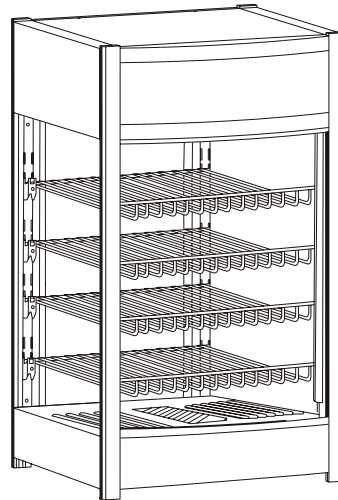

Removing Lime and Mineral Deposits:

1. Turn off the unit, unplug, and allow the unit to cooldown.
2. After the unit has cooled, remove and empty the water pan.
3. Fill the water pan with a mixture of 70% water and 30% white vinegar to a level where it covers the lime and mineral deposits.
4. Plug in and turn on the unit to the highest temperature and humidity settings. Allow the unit to run for 30 minutes.
5. Turn off the unit and unplug the power cord, allow unit to cool.
6. Allow the water pan to stand with the deliming solution for at least two hours (the time required will vary depending on the amount of deposits in the water tank).
7. Remove water pan, empty and flush with clean water.
8. Continue to fill and drain the water pan with clean water until the deliming solution is flushed out and the water flows clear.
9. Replace the rack, plug unit in and refill the water pan with distilled water.

NOTE: If lime and mineral deposits are still present in the water pan, repeat this procedure and increase the amount of time the de-liming mixture stands in the water pan.

WIRING DIAGRAMS

Rotating Models Only:

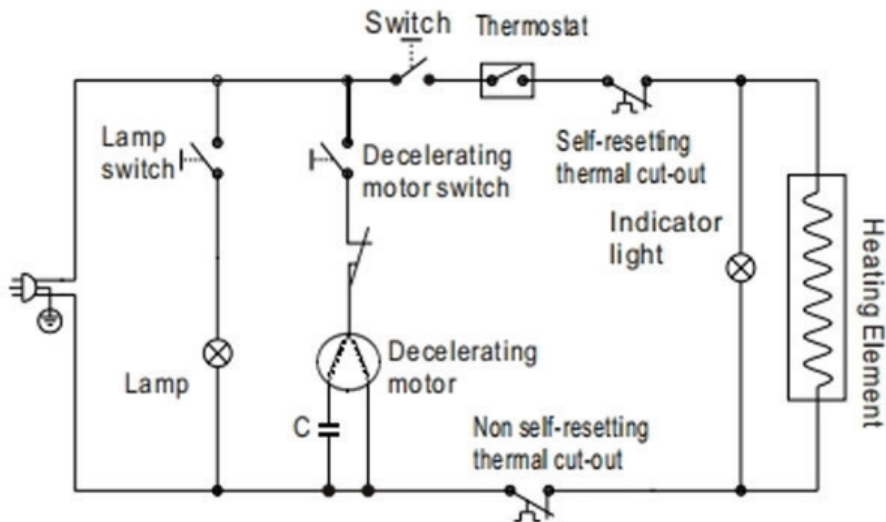

Non-Rotating Models Only:

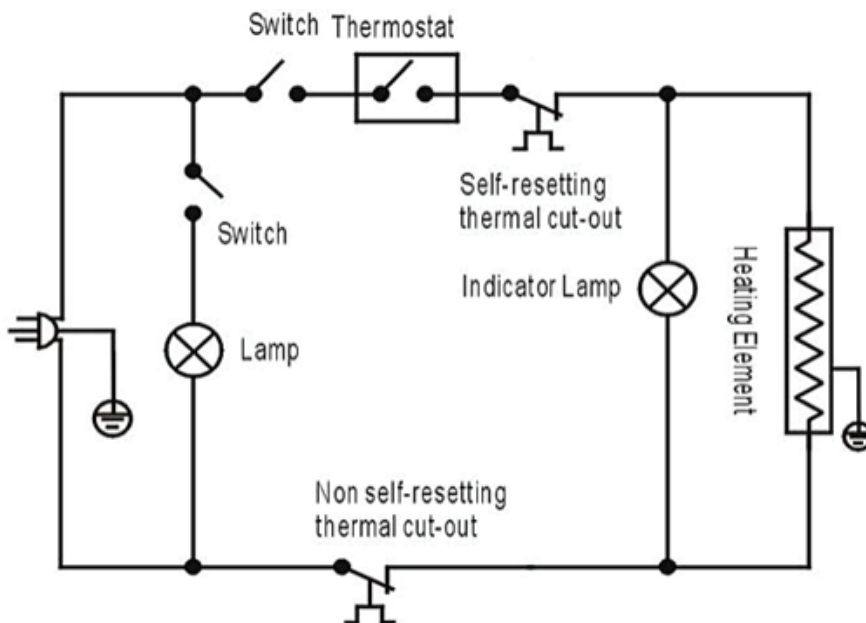

TROUBLESHOOTING

Issue	Reason	Solution
No lighting in the interior of the cabinet	Unit is not plugged in	Inspect power source, ensure power cord is undamaged
	LED light failure	Replace LED lights
Unit is not hot enough	Thermostat off	Dial in temperature
	Defective Thermostat or Heating Element	Contact place of purchase or authorized service agent
	Unit has not had enough time to preheat	Allow unit 30 minutes to reach operating temperature
	Temperature is set too low	Change the temperature to a higher setting
	Door(s) are not closed completely	Make sure door(s) are completely closed
Unit is too hot	Temperature is set too high	Change the temperature to a lower setting
	Unit is connected to incorrect power supply	Contact authorized service agent
	Defective Thermostat or Heating Element	Contact place of purchase or authorized service agent
Product is too dry	Door(s) are open	Make sure door(s) are completely closed
	Water pan is empty	Fill water pan up
Unit is not working at all	Unit is not plugged in	Plug unit into proper power supply
	Unit is not turned on	Turn unit on using on/off switch
	Circuit breaker tripped	Reset circuit breaker
	Controls are defective	Contact place of purchase or authorized service agent
	Defective thermostat or heating element	Contact place of purchase or authorized service agent