

# Hoshizaki America, Inc.

## Self-Contained Cubelet

### Models

C-101BAH

C-101BAH-DS

C-101BAH-AD

C-101BAH-ADDS



“A Superior Degree  
of Reliability”

[www.hoshizaki.com](http://www.hoshizaki.com)

## INSTRUCTION MANUAL



**⚠ WARNING**

Only qualified service technicians should install and service the appliance. To obtain the name and phone number of your local Hoshizaki Certified Service Representative, visit [www.hoshizaki.com](http://www.hoshizaki.com). No installation or service should be undertaken until the technician has thoroughly read this Instruction Manual. Likewise, the owner/manager should not proceed to operate the appliance until the installer has instructed them on its proper operation. Failure to install, operate, and maintain the appliance in accordance with this manual will adversely affect safety, performance, component life, and warranty coverage and may result in costly water damage. Proper installation is the responsibility of the installer. Product failure or property damage due to improper installation is not covered under warranty.

Hoshizaki provides this manual primarily to assist qualified service technicians in the installation, maintenance, and service of the appliance.

Should the reader have any questions or concerns which have not been satisfactorily addressed, please call, send an e-mail message, or write to the Hoshizaki Technical Support Department for assistance.

Phone: 1-800-233-1940; (770) 487-2331

Fax: 1-800-843-1056; (770) 487-3360

E-mail: [techsupport@hoshizaki.com](mailto:techsupport@hoshizaki.com)

HOSHIZAKI AMERICA, INC.

618 Highway 74 South

Peachtree City, GA 30269

Attn: Hoshizaki Technical Support Department

**NOTE:** To expedite assistance, all correspondence/communication **MUST** include the following information:

- Model Number \_\_\_\_\_
- Serial Number \_\_\_\_\_
- Complete and detailed explanation of the problem.

**IMPORTANT**

This manual should be read carefully before the appliance is installed and operated. Read the warnings and guidelines contained in this manual carefully as they provide essential information for the continued safe use and maintenance of the appliance. Retain this manual for any further reference that may be necessary.

**CONTENTS**

Important Safety Information ..... 4

I. Specifications..... 6

    A. Construction..... 6

    B. Electrical and Refrigerant Data ..... 6

    C. Dimensions/Connections ..... 7

        1. C-101BAH ..... 7

        2. C-101BAH-DS..... 8

        3. C-101BAH-AD..... 9

        4. C-101BAH-ADDS..... 10

II. Installation Instructions ..... 11

    A. Checks Before Installation..... 11

    B. Location..... 11

        1. General ..... 11

        2. Built-In Installation Site ..... 12

    C. Door ..... 13

        1. C-101BAH, C-101BAH-AD ..... 13

            a) Door Reversal ..... 13

        2. C-101BAH-DS, C-101BAH-ADDS..... 15

            a) Overlay Panel Fabrication and Attachment ..... 15

    D. Setup..... 23

    E. Electrical Connection ..... 23

    F. Water Supply and Drain Connections ..... 24

    G. Final Checklist ..... 26

III. Operating Instructions..... 27

    A. Important Notes About Usage..... 27

    B. Startup ..... 29

IV. Maintenance ..... 30

    A. Maintenance Schedule..... 31

    B. Cleaning and Sanitizing Instructions ..... 32

    C. Storage Bin Drain..... 34

    D. Condenser..... 35

    E. Optional Drain Pump HS-5061 ..... 36

V. Preparing the Appliance for Periods of Non-Use ..... 37

VI. Disposal..... 39

---

## Important Safety Information

Throughout this manual, notices appear to bring your attention to situations which could result in death, serious injury, damage to the appliance, or damage to property.

**⚠ WARNING** Indicates a hazardous situation which could result in death or serious injury.


**NOTICE** Indicates a situation which could result in damage to the appliance or property.

**IMPORTANT** Indicates important information about the installation, use, and care of the appliance.

### **⚠ WARNING**

The appliance should be destined only to the use for which it has been expressly conceived. Any other use should be considered improper and therefore dangerous. The manufacturer cannot be held responsible for injury or damage resulting from improper, incorrect, and unreasonable use. Failure to install, operate, and maintain the appliance in accordance with this manual will adversely affect safety, performance, component life, and warranty coverage and may result in costly water damage.

**To reduce the risk of death, electric shock, serious injury, or fire, follow basic precautions including the following:**

- Only qualified service technicians should install and service the appliance.
- The appliance must be installed in accordance with applicable national, state, and local codes and regulations.
- The appliance requires an independent power supply of proper capacity. See the nameplate for electrical specifications. Failure to use an independent power supply of proper capacity can result in a tripped breaker, blown fuse, damage to existing wiring, or component failure. This could lead to heat generation or fire.
- **THE APPLIANCE MUST BE GROUNDED:** The appliance is equipped with a NEMA 5-15 three-prong grounding plug  to reduce the risk of potential shock hazards. It must be plugged into a properly grounded, independent 3-prong wall outlet. If the outlet is a 2-prong outlet, it is your personal responsibility to have a qualified electrician replace it with a properly grounded, independent 3-prong wall outlet. Do not remove the ground prong from the power cord and do not use an adapter plug. Failure to properly ground the appliance could result in death or serious injury.
- Do not use an extension cord.
- To reduce the risk of electric shock, do not touch the control switch or plug with damp hands. Make sure the control switch is in the "OFF" position before plugging in or unplugging the appliance.
- Do not use an appliance with a damaged power cord. The power cord should not be altered, jerked, bundled, weighed down, pinched, or tangled. Such actions could result in electric shock or fire. To unplug the appliance, be sure to pull the plug, not the cord, and do not jerk the cord.
- Do not make any alterations to the appliance. Alterations could result in electric shock, injury, fire, or damage to the appliance.
- Do not place fingers or any other objects into the ice discharge opening.

## **⚠ WARNING, continued**

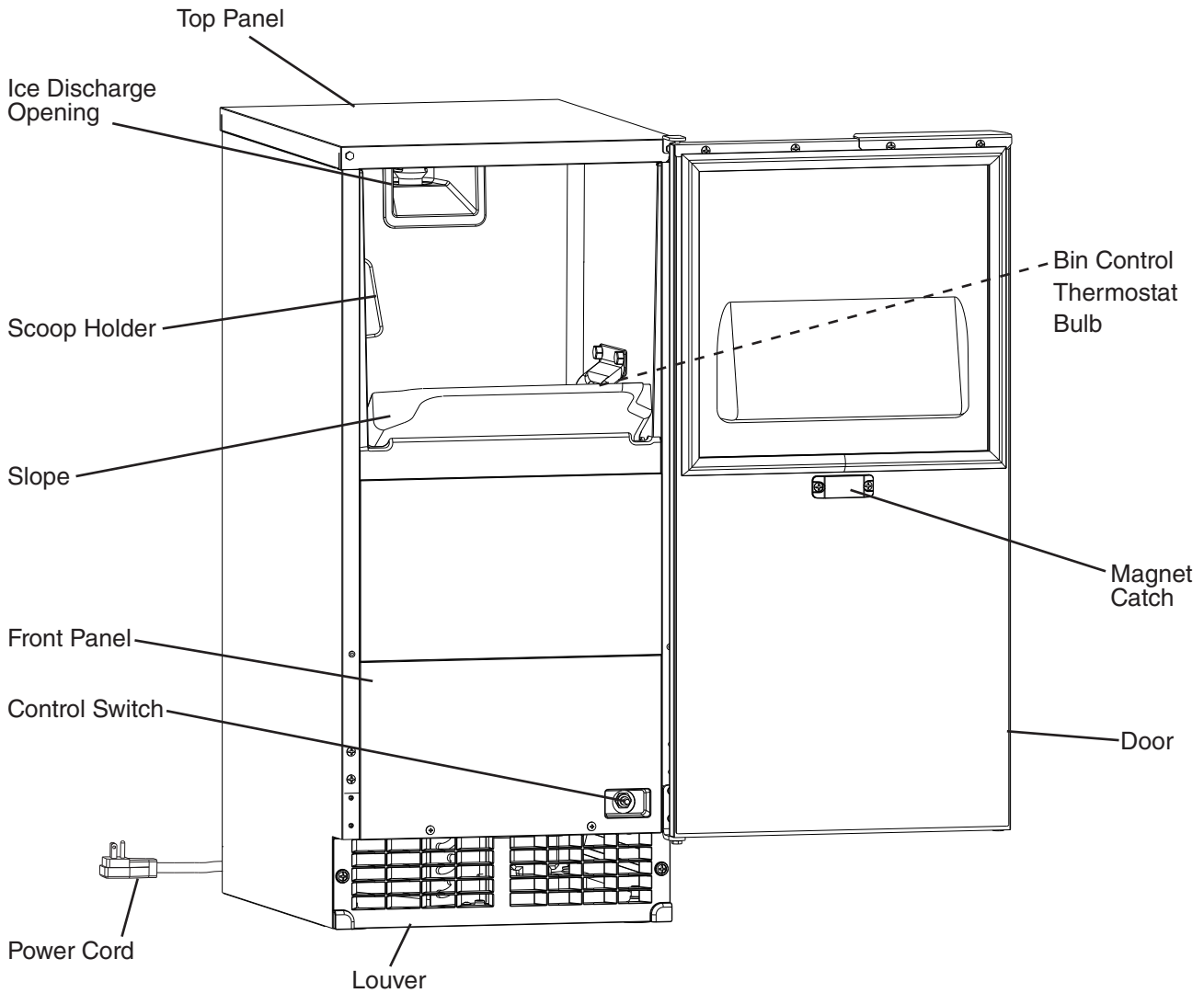
- The appliance is not intended for use by persons (including children) with reduced physical, sensory, or mental capabilities, or lack of experience and knowledge, unless they have been given supervision or instruction concerning use of the appliance by a person responsible for their safety.
- Young children should be properly supervised around the appliance.
- Do not climb, stand, or hang on the appliance or appliance door or allow children or animals to do so. Serious injury could occur or the appliance could be damaged.
- Be careful not to pinch fingers when opening and closing the door. Be careful when opening and closing the door when children are in the area.
- Do not use combustible spray or place volatile or flammable substances near the appliance. They might catch fire.
- Keep the area around the appliance clean. Dirt, dust, or insects in the appliance could cause harm to individuals or damage to the appliance.

## ***NOTICE***

- Protect the floor when moving the appliance to prevent damage to the floor.
- Follow the water supply, drain connection, and maintenance instructions carefully to reduce the risk of costly water damage.
- In areas where water damage is a concern, install in a contained area with a floor drain.
- Install the appliance in a location that stays above freezing. Normal operating ambient temperature must be within 45°F to 100°F (7°C to 38°C).
- If using the optional drain pump (HS-5061), test its operation every time the appliance is cleaned and sanitized. See "IV.E. Optional Drain Pump HS-5061" for details. If the optional drain pump is not operating properly, water could back up and overflow, leading to costly water damage.
- To help ensure the storage bin drain remains clear, follow the instructions in "IV.C. Storage Bin Drain" once every 3 months or as often as necessary for conditions. If the storage bin drain becomes clogged, water could build up in the bin and overflow, leading to costly water damage.
- If water collects in the bin and will not drain, turn off the appliance and close the water supply line shut-off valve. Call for service.
- If water seeps from the base of the appliance, turn off the appliance and close the water supply line shut-off valve. Call for service. Failure to do so could lead to costly water damage.
- Do not leave the appliance on during extended periods of non-use, extended absences, or in sub-freezing temperatures. To properly prepare the appliance for these occasions, follow the instructions in "V. Preparing the Appliance for Periods of Non-Use."
- Keep ventilation openings, in the appliance enclosure or in the built-in structure, clear of obstruction.
- Do not place objects on top of the appliance.
- The storage bin is for ice use only. Do not store anything else in the storage bin.

# I. Specifications

## A. Construction



## B. Electrical and Refrigerant Data

The nameplate provides electrical and refrigerant data. The nameplate is located inside the storage bin. For certification marks, see the nameplate.

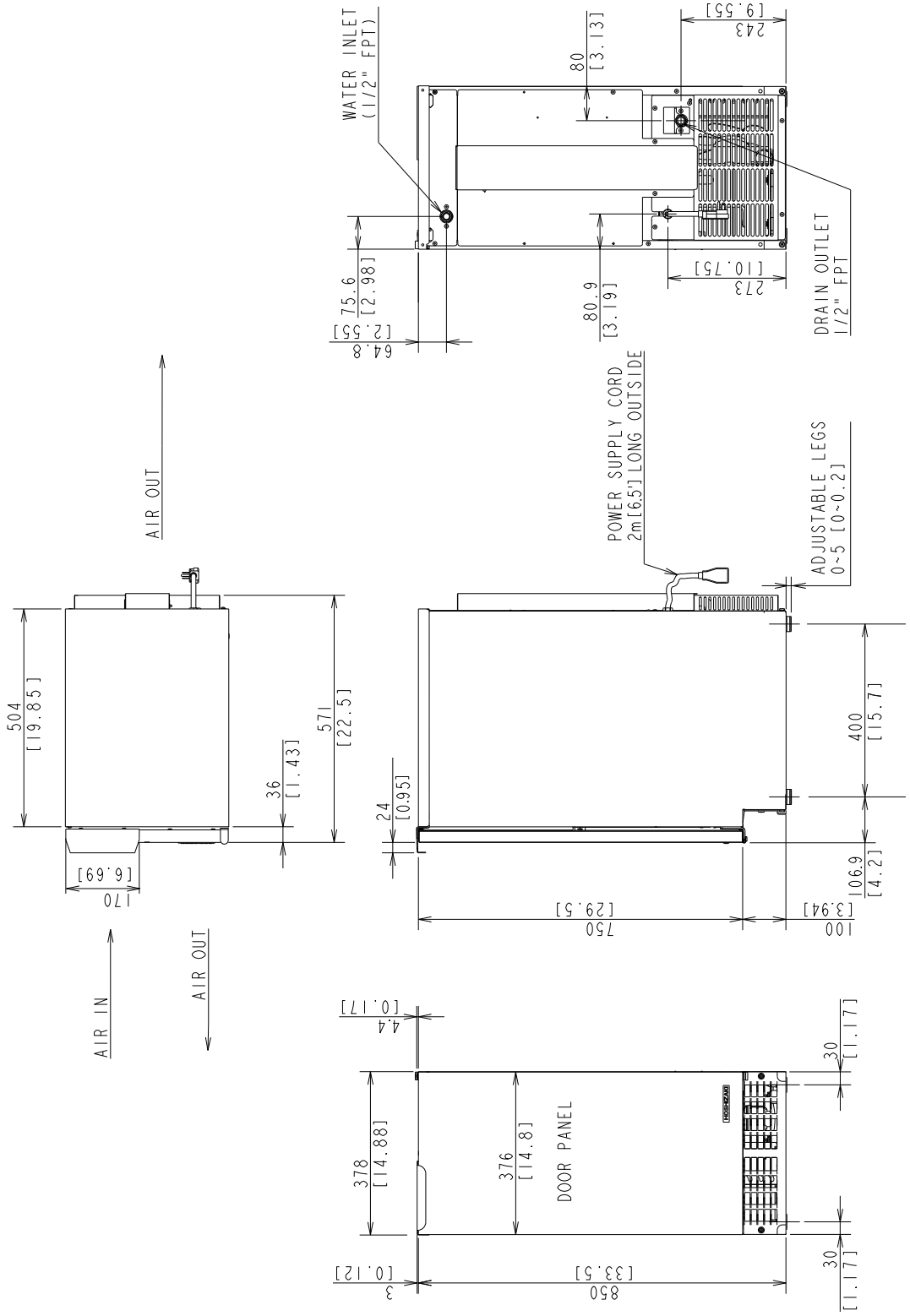
We reserve the right to make changes in specifications and design without prior notice.

<b>Model Number</b>	<b>C-101BAH C-101BAH-DS C-101BAH-AD C-101BAH-ADDS</b>
AC Supply Voltage	115-120/60/1
Amperes	4.0 AMPS
Design Pressure	HI-240PSI LO-120PSI
Refrigerant	134a 3.17 OZ.

# C. Dimensions/Connections

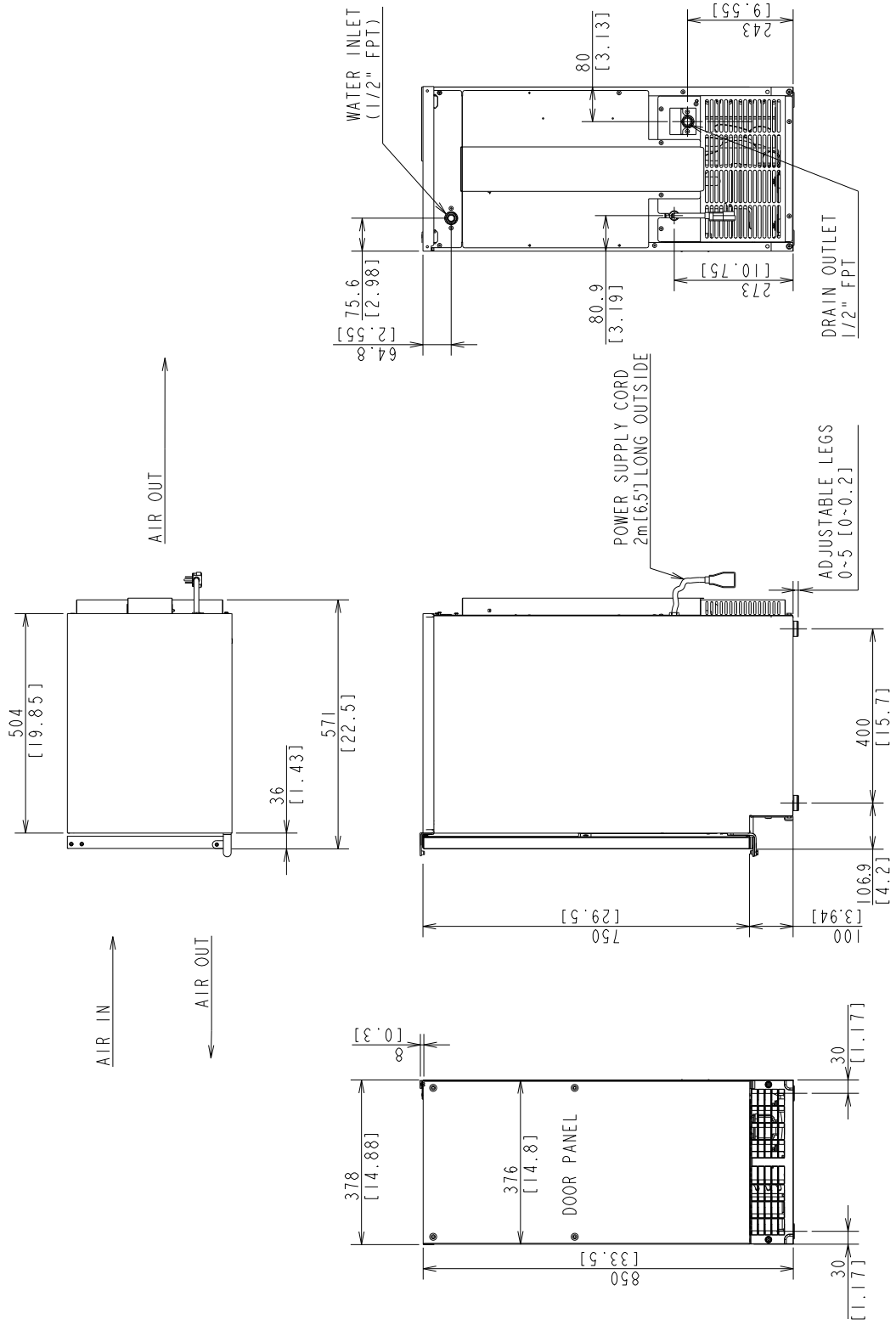
## 1. C-101BAH

Units: mm [in.]



## 2. C-101BAH-DS

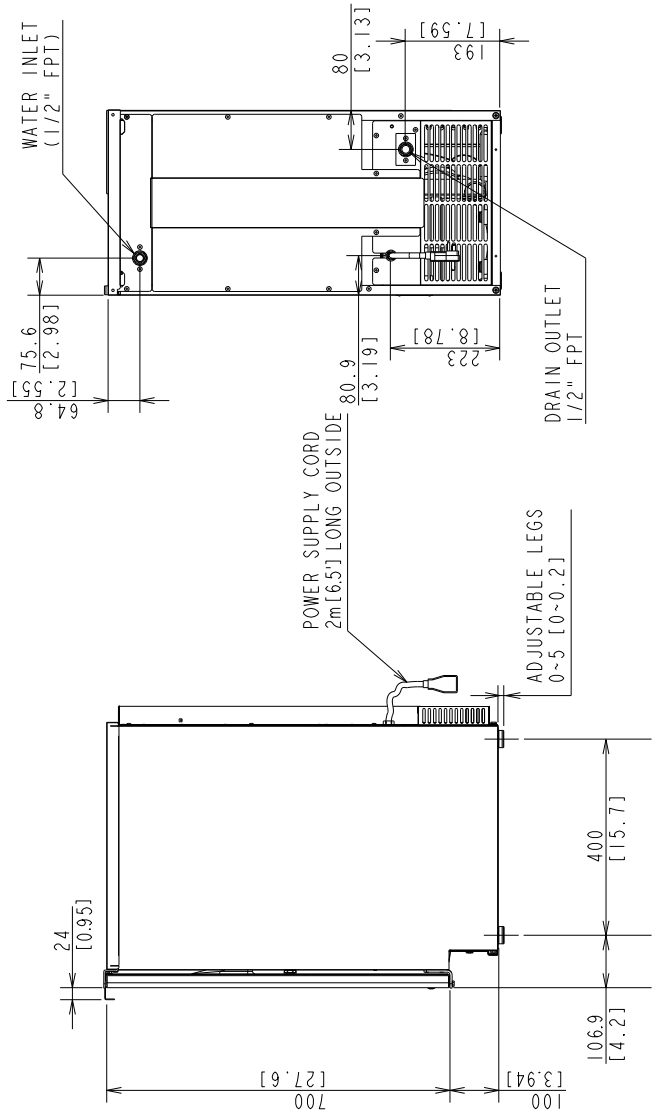
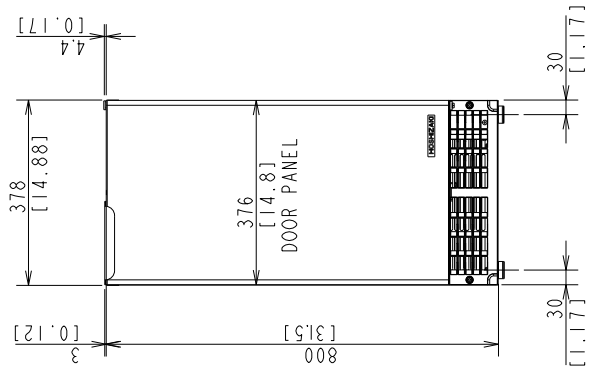
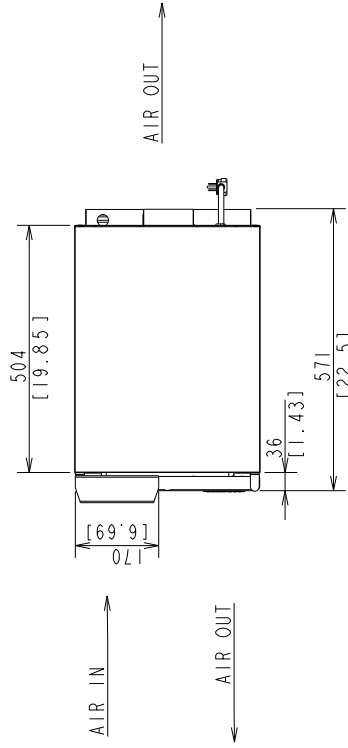
Units: mm [in.]





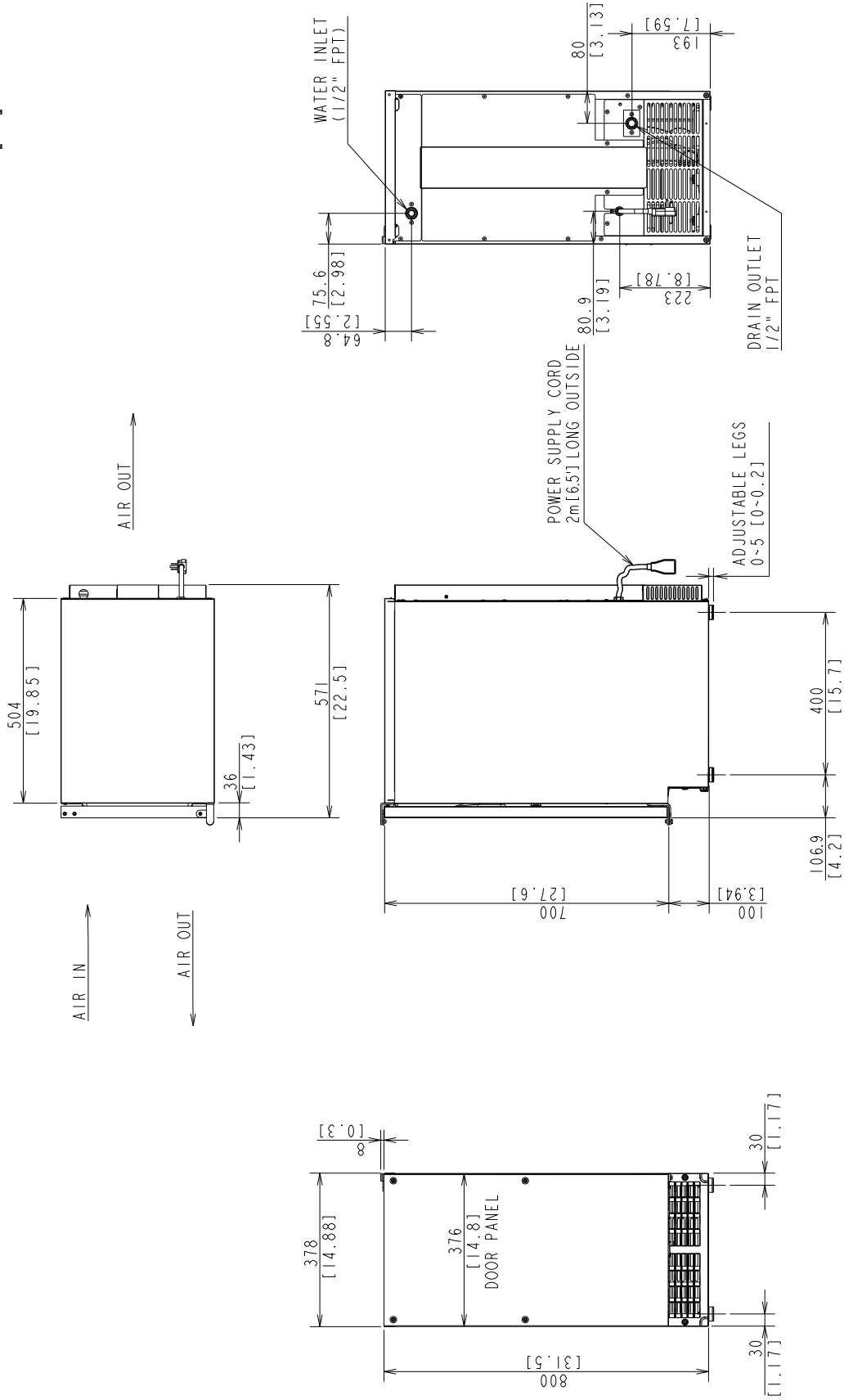
### 3. C-101BAH-AD

Units: mm [in.]



# 4. C-101BAH-ADDS

Units: mm [in.]



---

## II. Installation Instructions

### **⚠ WARNING**

- The appliance must be installed in accordance with applicable national, state, and local codes and regulations.
- **CHOKING HAZARD:** Ensure all components, fasteners, and thumbscrews are securely in place after installation. Make sure that none have fallen into the storage bin.

### A. Checks Before Installation

- Visually inspect the exterior of the shipping container and immediately report any damage to the carrier. Upon opening the container, any concealed damage should also be immediately reported to the carrier.
- Remove the shipping carton, tape, and packing material. If any are left in the appliance, it will not work properly.
- Remove the package containing the accessories.
- Remove the protective plastic film from the panels. If the appliance is exposed to the sun or to heat, remove the film after the appliance cools.
- See the nameplate inside the storage bin, and check that your voltage supplied corresponds with the voltage specified on the nameplate.

### B. Location

#### 1. General

The appliance is approved for indoor or outdoor use.

### **NOTICE**

- Normal operating ambient temperature must be within 45°F to 100°F (7°C to 38°C); Normal operating water temperature must be within 45°F to 90°F (7°C to 32°C). Operation of the appliance, for extended periods, outside of these normal temperature ranges may affect appliance performance.
- The appliance will not work at sub-freezing temperatures. To prevent damage to the water supply line, drain the appliance if the air temperature is going to go below 32°F (0°C). See "V. Preparing the Appliance for Periods of Non-Use."

- The appliance should not be located next to ovens, grills, or other high heat producing equipment.
- The location must provide a firm and level foundation for the appliance.
- The appliance requires no side or top clearance. But allow enough space at rear for water supply and drain connections and at least 15" (38 cm) clearance at front.
- The appliance must be at floor level on a finished floor even if under a cabinet. In areas where water damage is a concern, install in a contained area with a floor drain.

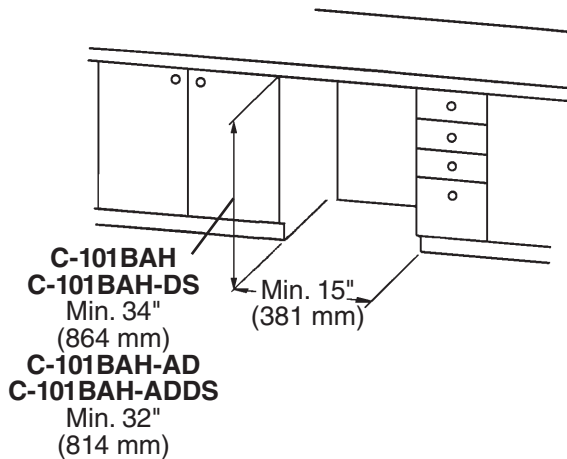
## 2. Built-In Installation Site

### NOTICE

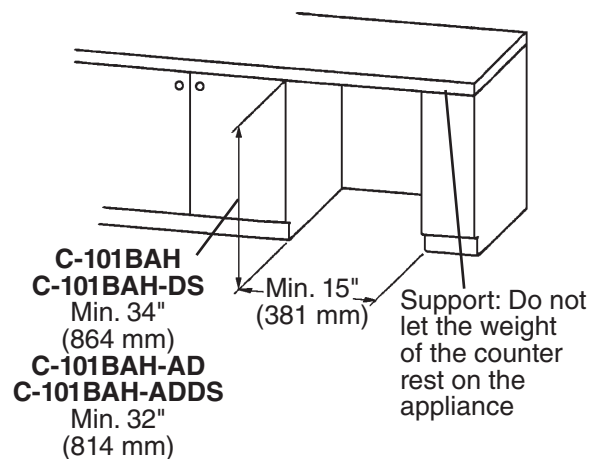
- Do not let the weight of the counter rest on the appliance.
- Do not install the appliance in a corner where the door will interfere with other equipment or where the appliance cannot be pulled out for service.

Installation Space			
Model	Height	Width	Depth
C-101BAH C-101BAH-DS	34" (864 mm) minimum	15" (381 mm) minimum	24" (610 mm) minimum
C-101BAH-AD C-101BAH-ADDS	32" (814 mm) minimum		

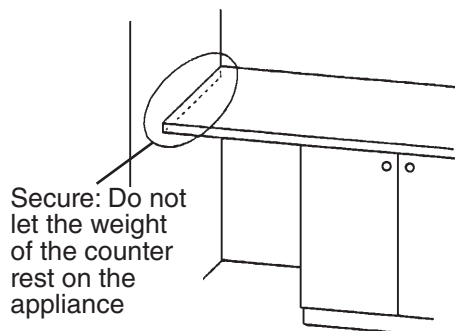
### Between Two Cabinets



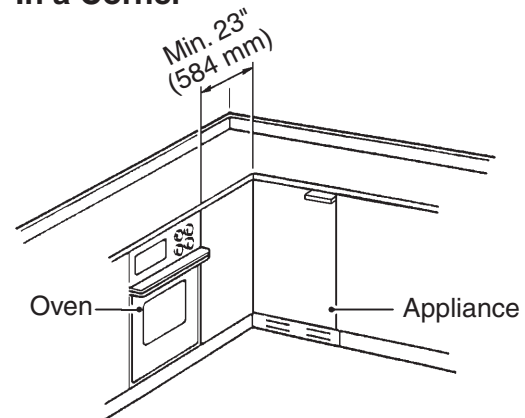
### Between a Cabinet and the End of a Counter



### Between a Cabinet and a Wall or Tall Cabinet



### In a Corner



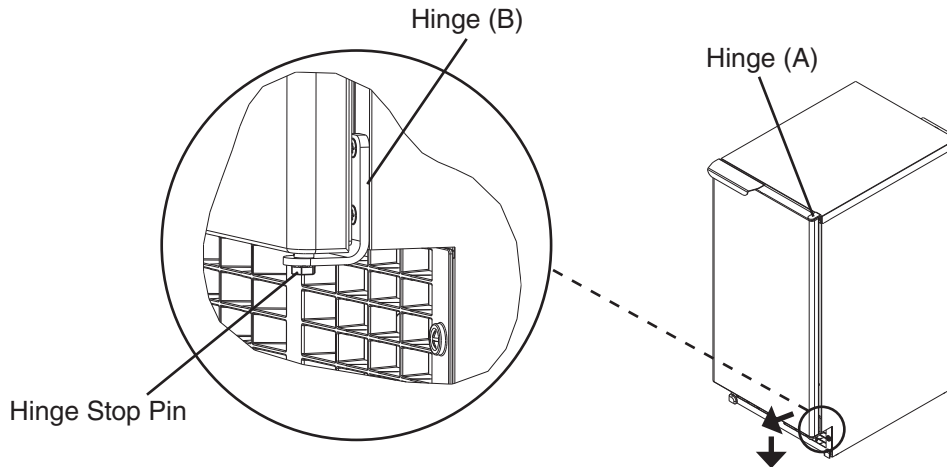
## C. Door

### 1. C-101BAH, C-101BAH-AD

#### a) Door Reversal

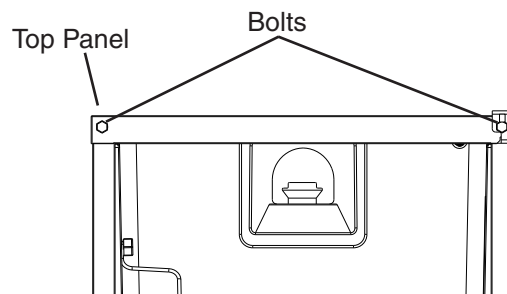
If you would like to reverse the door swing, follow the steps below. Otherwise, skip to section "II.D. Setup."

- 1) While maintaining a hold on the door, remove the hinge stop pin from hinge (B). Pull out the bottom of the door slightly and gently remove the door from hinge (A). See Fig. 1.



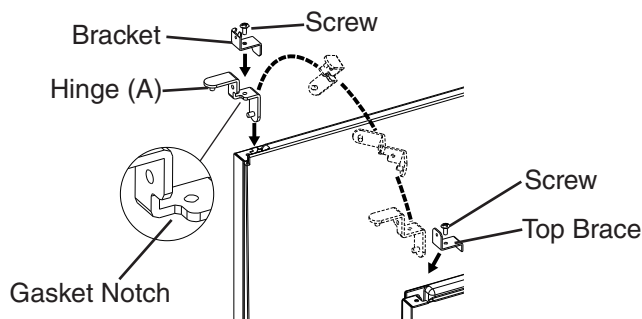
**Fig. 1**

- 2) Remove the 2 bolts securing the top panel, then lift it off. See Fig. 2.



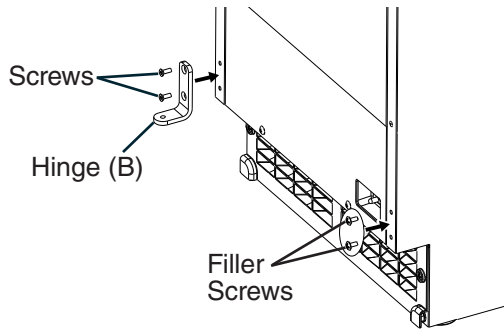
**Fig. 2**

- 3) Remove hinge (A) and the bracket from the right side of the appliance and the top brace from the left side. Rotate hinge (A) to position the gasket notch to the inside, then fasten hinge (A) and the bracket to the left side and the top brace to the right side. See Fig. 3.

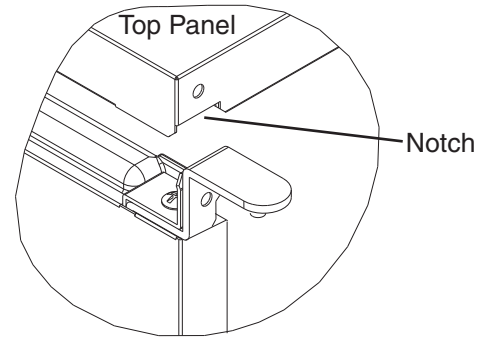


**Fig. 3**

- 4) Remove hinge (B) from the right side of the appliance and the 2 filler screws from the left side. Attach the 2 filler screws to the right side and attach hinge (B) to the left side. See Fig. 4.
- 5) Rotate the top panel 180° from its previous position. This brings the notch that was previously in the right rear to the left front. See Fig. 5. Hook the rear part of the panel on the body, then secure the front with the 2 bolts removed in step 2.

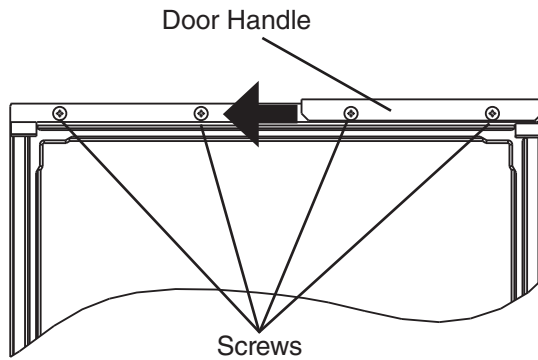


**Fig. 4**

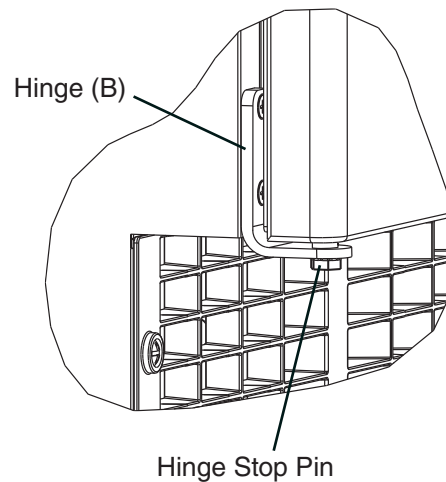


**Fig. 5**

- 6) Remove the 2 screws attaching the door handle and also remove the other 2 screws indicated in the illustration. Use 2 of the screws to attach the handle to the other side of the door and attach the other 2 screws in the remaining 2 holes. See Fig. 6.
- 7) Attach the door to hinge (A), then continue to maintain a hold on the door. Screw the hinge stop pin into hinge (B) until it is tight. See Fig. 7.



**Fig. 6**



**Fig. 7**

## 2. C-101BAH-DS, C-101BAH-ADDS

### a) Overlay Panel Fabrication and Attachment

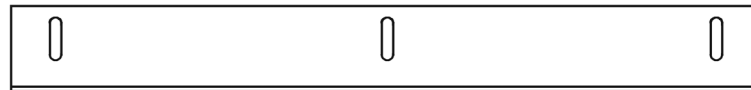
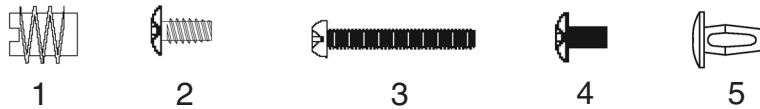
#### **IMPORTANT**

The overlay panel must be crafted by a professional cabinet maker to ensure quality results.

#### **(1) Parts**

Ensure that all parts required for the overlay panel assembly are contained in the accessories bag.

Overlay Panel Parts			
No.	Description	Part Number	Qty.
1	Threaded Wood Insert	4A4004-01	6
2	T2 Screw 4x8 SS	7P32-0408	3
3	Pan Head Screw M4x25 SS	7C12-0425	4
4	Truss Head Screw M4x8 SS	7C32-0408	2
5	Canoe Clip	4A0629-02	2
6	Sheet Metal Bracket	4A3998-01	1

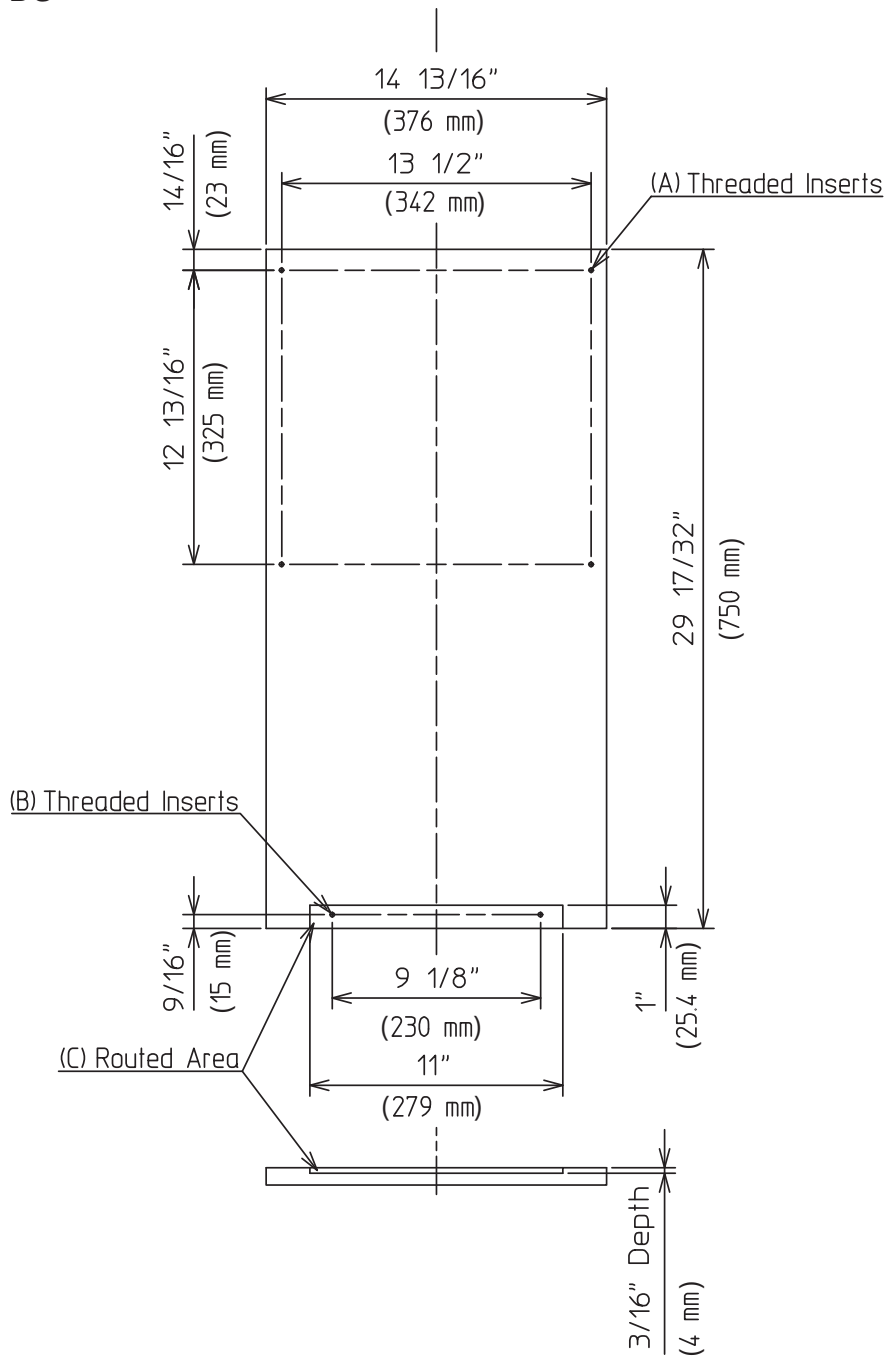


6

**(2) Overlay Panel Specification**

Use the specification that applies to your appliance (C-101BAH-**DS** or C-101BAH-**ADDS**) and the directions that follow to prepare your overlay panel.

(a) C-101BAH-DS

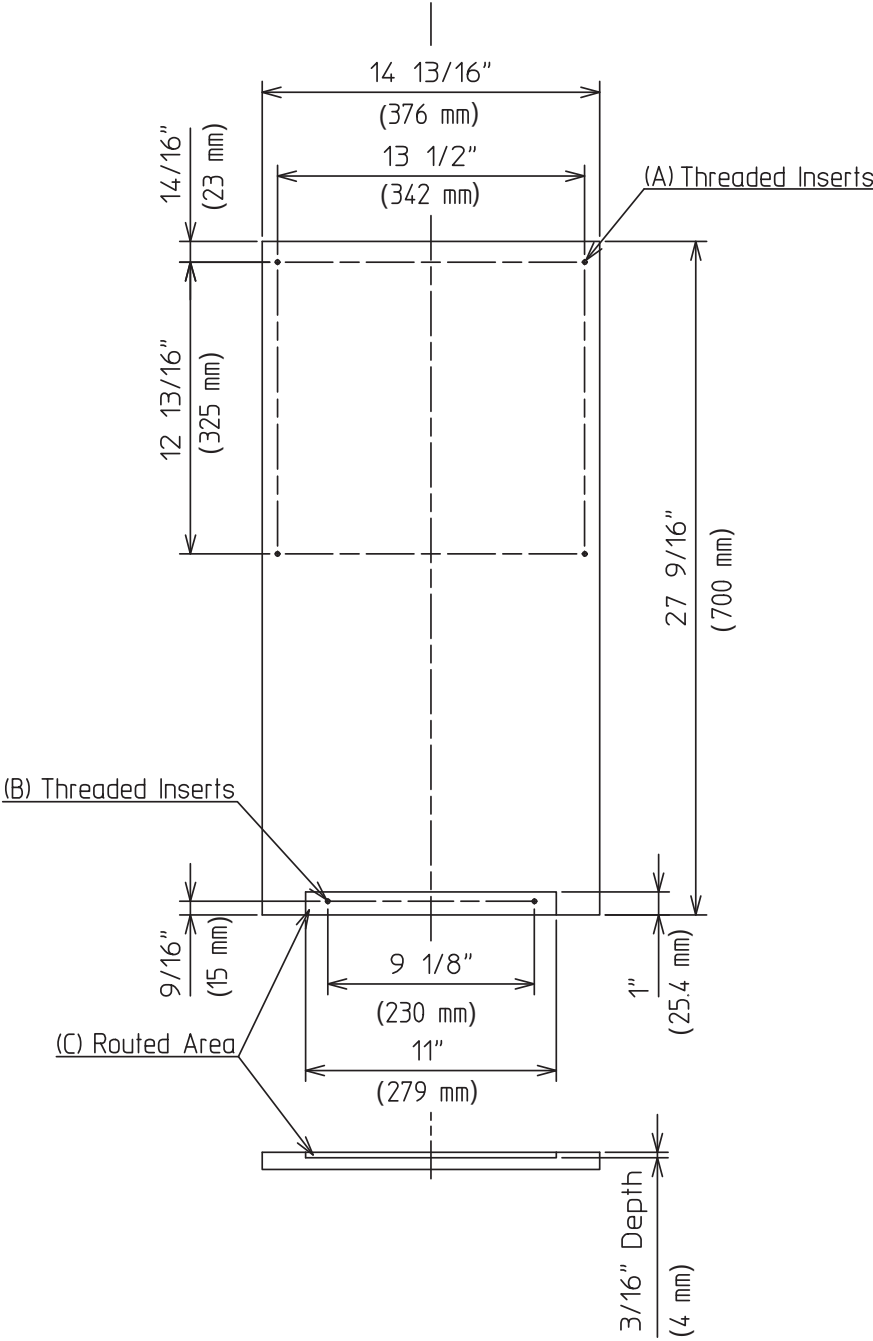


**C-101BAH-DS Overlay Panel Specification**

Overlay Panel Height	29 17/32" (750 mm)
Overlay Panel Width	14 13/16" (376 mm)
Overlay Panel Thickness	5/8" (16 mm) minimum; 3/4" (19 mm) maximum
Overlay Panel and Door Weight (total)	20 lb. (9 kg) maximum



(b) C-101BAH-ADDS

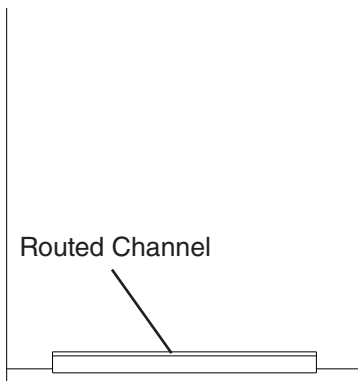


<b>C-101BAH-ADDS Overlay Panel Specification</b>	
Overlay Panel Height	27 9/16" (700 mm)
Overlay Panel Width	14 13/16" (376 mm)
Overlay Panel Thickness	5/8" (16 mm) minimum; 3/4" (19 mm) maximum
Overlay Panel and Door Weight (total)	20 lb. (9 kg) maximum

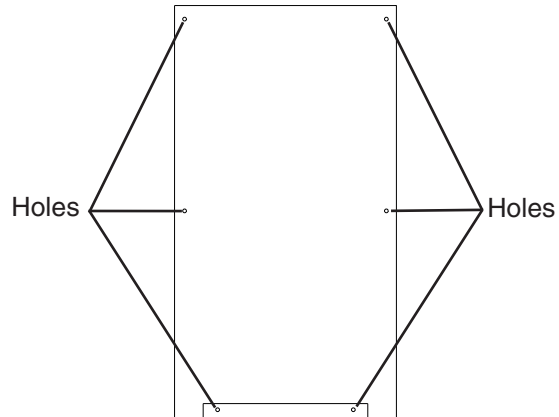
### **(3) Fabrication of Overlay Panel**

Fabricate the overlay panel as outlined in the specification on the previous page and the instructions below.

- 1) Rout a channel at the bottom of the overlay panel to the proper dimensions. See "(C) Routed Area" in the specification diagram and Fig. 8.
- 2) Drill six 1/4" diameter (hardwood may require slightly larger diameter) holes 3/8" (10 mm) deep in the locations designated. **NOTICE! Use care when drilling holes for mounting hardware. All drilled holes must be straight and drilled to the correct diameter and depth.** See "(A) Threaded Inserts" and "(B) Threaded Inserts" in the specification diagram and Fig. 9.

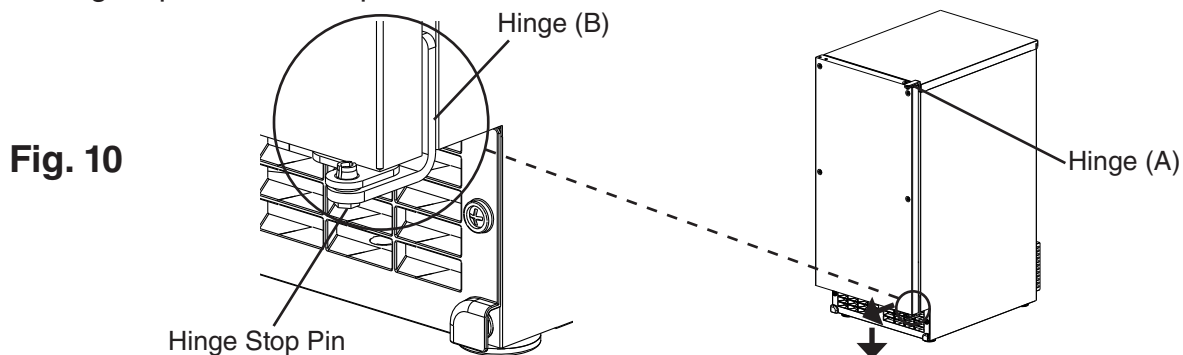


**Fig. 8**



**Fig. 9**

- 3) Screw the 6 threaded wood inserts into the 1/4" holes drilled in the previous step. Make sure that the inserts are threaded straight and that the tops of the inserts are flush to the overlay panel surface. Otherwise, the overlay panel cannot be properly fastened to the door.
- 4) Mount the door handle hardware. Hoshizaki recommends that the door handle hardware be mounted on the edge opposite of the door hinge side (optional hinge reversal is covered in step 6. Countersunk screw heads are required to ensure that the hardware fasteners do not interfere with the overlay panel fitting flush with the door.
- 5) While maintaining a hold on the door, remove the hinge stop pin from hinge (B). Pull out the bottom of the door slightly and gently remove the door from hinge (A). See Fig. 10. If you are leaving the door right-hinged, skip to step 7. If you would like to reverse the door hinges, proceed to step 6.

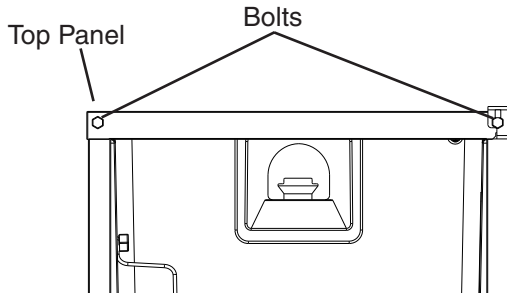


**Fig. 10**

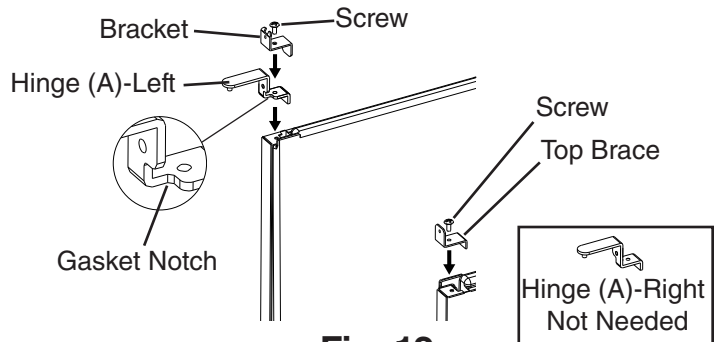
6) If you would like to reverse the door hinges, do the following:

- a) Contact your local distributor to purchase Hoshizaki Kit HS-0229. The kit contains "hinge (A)-left."
- b) Remove the 2 bolts securing the top panel, then lift it off. See Fig. 11.
- c) Remove hinge (A)-right and the bracket from the right side of the appliance. Set aside hinge (A)-right; it is not needed. Remove the top brace from the left side. Fasten hinge (A)-left and the bracket to the left side and the top brace to the right side. See Fig. 12.

Note: When on the proper side, the gasket notch for hinge (A) is to the inside.

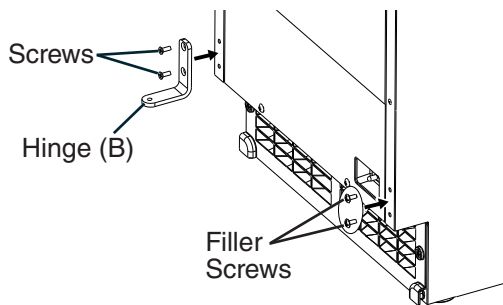


**Fig. 11**

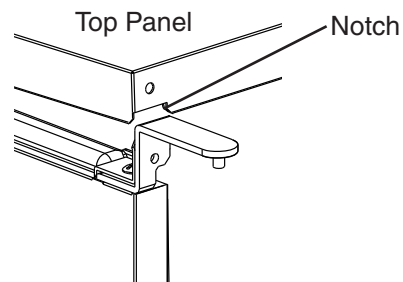


**Fig. 12**

- d) Remove hinge (B) from the right side of the appliance and the 2 filler screws from the left side. Attach the 2 filler screws to the right side and attach hinge (B) to the left side. See Fig. 13.
- e) Rotate the top panel 180° from its previous position. This brings the notch that was previously in the right rear to the left front. See Fig. 14. Hook the rear part of the panel on the body, then secure the front with the 2 bolts removed in step 6a.

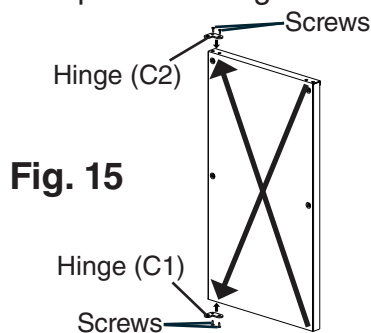


**Fig. 13**



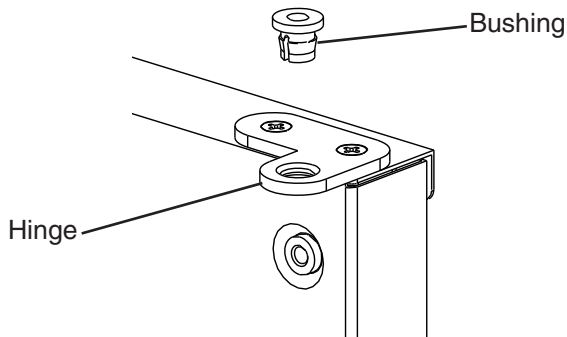
**Fig. 14**

- f) Remove hinge (C1) from the top right part of the door, flip it and reattach to the bottom left. Remove hinge (C2) from the bottom right part of the door, flip it and reattach to the top left. See Fig. 15. Proceed to step 7.

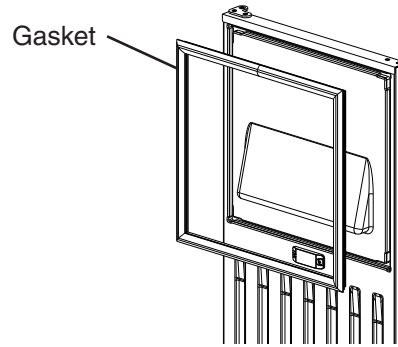


**Fig. 15**

- 7) Remove the bushings from hinge (C1) and hinge (C2) (the hinges attached to the door). See Fig. 16.
- 8) Remove the gasket from the door. See Fig. 17.

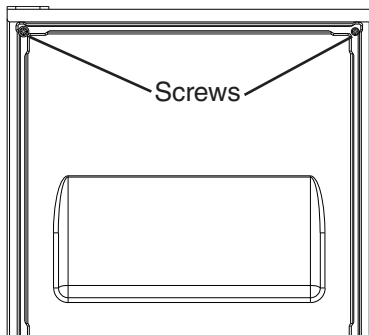


**Fig. 16**

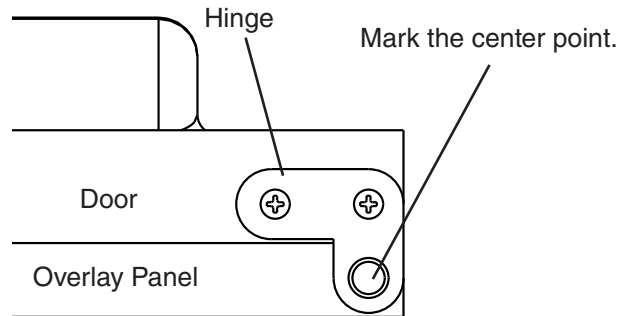


**Fig. 17**

- 9) Temporarily fasten the overlay panel to the door using 2 of the M4x25 pan head screws provided. **NOTICE! Ensure that the back surface of overlay panel is flat before attaching.** See Fig. 18.
- 10) Mark the centerpoint of the hinge (C1) and hinge (C2) holes that extend over the overlay panel. See Fig. 19.
- 11) Remove the overlay panel from the door.



**Fig. 18**

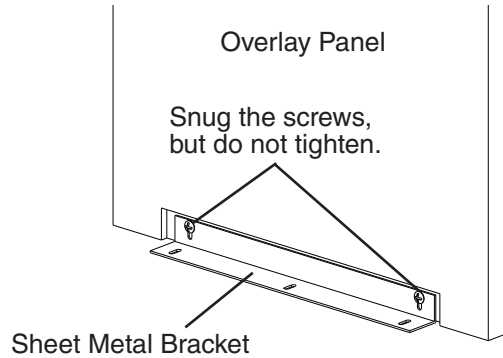


**Fig. 19**

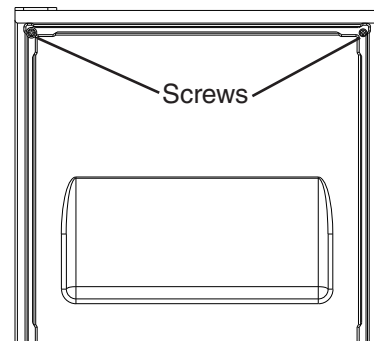
- 12) Drill 3/8" diameter holes 1/4" (7 mm) deep where you marked on the overlay panel to accommodate the hinge (C1) and hinge (C2) bushings.

**(4) Attachment of Overlay Panel to Door**

- 1) Fasten the sheet metal bracket to the overlay panel using the two M4x8 truss head screws provided. **Snug the screws, but do not tighten.** See Fig. 20.
- 2) Temporarily fasten the overlay panel to the door using 2 of the M4x25 pan head screws provided. See Fig. 21.

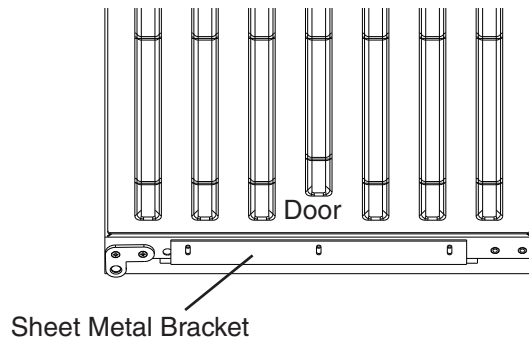


**Fig. 20**

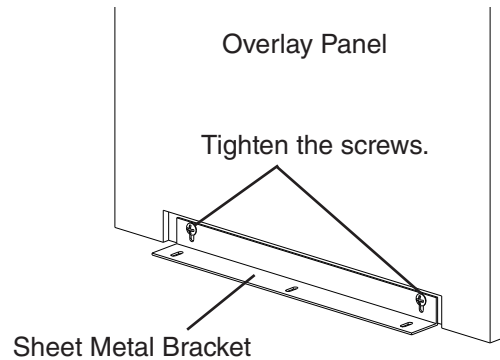


**Fig. 21**

- 3) Adjust the sheet metal bracket so that it is flush with the bottom of the door. See Fig. 22.
- 4) Remove the overlay panel from the door and tighten the two M4x8 truss head screws securing the sheet metal bracket to the overlay panel. See Fig. 23.

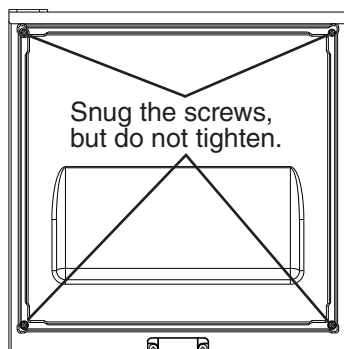


**Fig. 22**

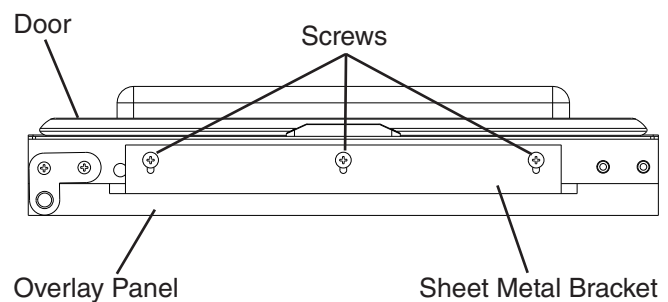


**Fig. 23**

- 5) Fasten the overlay panel to the door using the four M4x25 pan head screws provided. **Snug the screws, but do not tighten.** See Fig. 24.
- 6) Fasten the sheet metal bracket to the bottom of the door with the three T2 screws provided. Tighten the screws to the door. See Fig. 25.

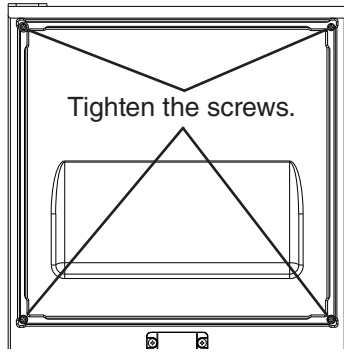


**Fig. 24**

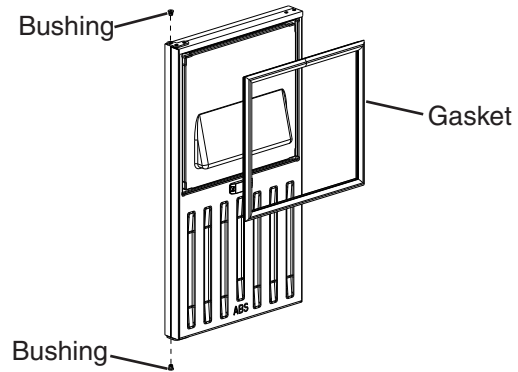


**Fig. 25**

- 7) Tighten the four M4×25 pan head screws installed in step 5. See Fig. 26.
- 8) Replace the door gasket in its proper orientation. Reinsert the bushings into hinge (C1) and hinge (C2) (the hinges attached to the door). See Fig. 27.

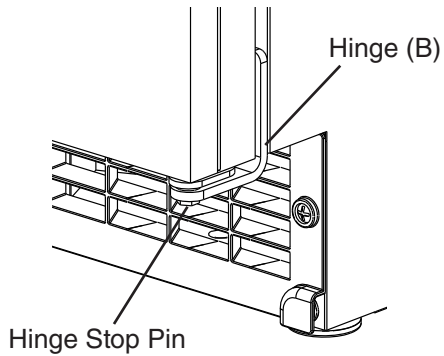


**Fig. 26**

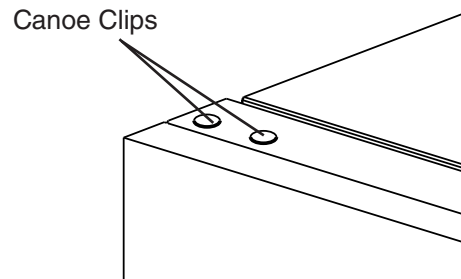


**Fig. 27**

- 9) Attach the door to hinge (A), then continue to maintain a hold on the door. Screw the hinge stop pin into hinge (B) until it is tight. See Fig. 28.
- 10) Insert the 2 canoe clips included in the accessory bag into the holes on top of the door. See Fig. 29.



**Fig. 28**




**Fig. 29**

## D. Setup

- 1) Position the appliance in the selected permanent location.
- 2) Level the appliance from side-to-side and front-to-rear by adjusting the feet.

## E. Electrical Connection

### WARNING

- Electrical connection must meet national, state, and local electrical code requirements. Failure to meet these code requirements could result in death, electric shock, serious injury, fire, or damage.
  - The appliance requires an independent power supply of proper capacity. See the nameplate for electrical specifications. Failure to use an independent power supply of proper capacity can result in a tripped breaker, blown fuse, damage to existing wiring, or component failure. This could lead to heat generation or fire.
  - **THE APPLIANCE MUST BE GROUNDED:** The appliance is equipped with a NEMA 5-15 three-prong grounding plug  to reduce the risk of potential shock hazards. It must be plugged into a properly grounded, independent 3-prong wall outlet. If the outlet is a 2-prong outlet, it is your personal responsibility to have a qualified electrician replace it with a properly grounded, independent 3-prong wall outlet. Do not remove the ground prong from the power cord and do not use an adapter plug. Failure to properly ground the appliance could result in death or serious injury.
  - Do not use an extension cord.
  - To reduce the risk of electric shock, do not touch the control switch or plug with damp hands. Make sure the control switch is in the "OFF" position before plugging in or unplugging the appliance.
  - Do not use an appliance with a damaged power cord. The power cord should not be altered, jerked, bundled, weighed down, pinched, or tangled. Such actions could result in electric shock or fire. To unplug the appliance, be sure to pull the plug, not the cord, and do not jerk the cord.
  - The GREEN ground wire in the factory-installed power cord is connected to the appliance. If it becomes necessary to remove or replace the power cord, be sure to connect the power cord's ground wire to this screw upon reattachment.
- Usually an electrical permit and services of a licensed electrician are required.
  - The maximum allowable voltage variation is  $\pm 10$  percent of the nameplate rating.
  - For optional drain pump (HS-5061) installation, refer to the instructions included with the pump.

## F. Water Supply and Drain Connections

### **⚠ WARNING**

Water supply and drain connections must be installed in accordance with applicable national, state, and local regulations.

### **NOTICE**

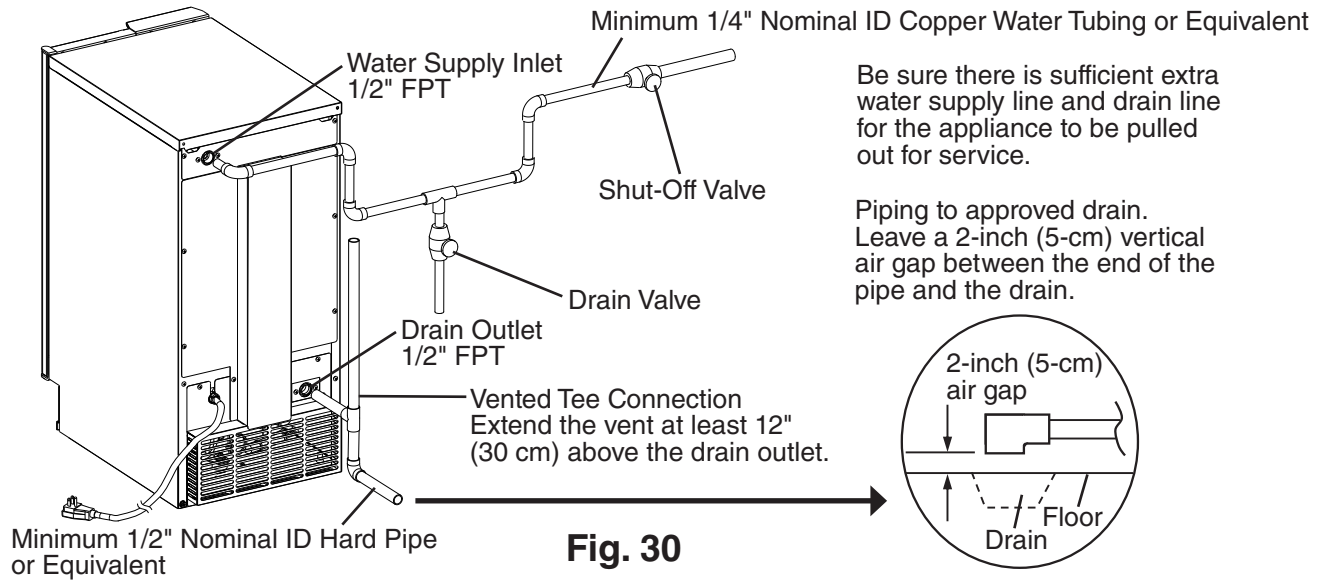
- Normal operating water temperature must be within 45°F to 90°F (7°C to 32°C). Operation of the appliance, for extended periods, outside of this normal temperature range may affect appliance performance.
- Water supply pressure must be a minimum of 7 PSIG and a maximum of 113 PSIG. If the pressure exceeds 113 PSIG, the use of a pressure reducing valve is required.
- External filters, strainers, or softeners may be required depending on water quality. Contact your local Hoshizaki Certified Service Representative or local Hoshizaki distributor for recommendations.
- Connect to potable water supply only. Do not connect to a hot-water supply.
- In areas where water damage is a concern, install in a contained area with a floor drain.
- Water line installation to the appliance is not warranted by Hoshizaki.
- Water-hammer issues must be resolved by a qualified plumber before installing the appliance. Water hammer can cause appliance damage that may lead to water leakage or flooding.
- A minimum of 1/2" nominal ID hard pipe or equivalent is required for the drain line. Installing a smaller diameter drain line will reduce water flow and may lead to water leakage or flooding.
- If using the optional drain pump (HS-5061), test its operation every time the appliance is cleaned and sanitized. See "IV.E. Optional Drain Pump HS-5061" for details. If the optional drain pump is not operating properly, water could back up and overflow, leading to costly water damage.

<b>Water Supply Inlet</b>	<b>Minimum Water Supply Line Size</b>	<b>Drain Outlet</b>	<b>Minimum Drain Line Size</b>
1/2" Female Pipe Thread (FPT)	1/4" Nominal ID Copper Water Tubing or Equivalent	1/2" Female Pipe Thread (FPT)	1/2" Nominal ID Hard Pipe or Equivalent

- A plumbing permit and services of a licensed plumber may be required in some areas.
- A water supply line shut-off valve and drain valve must be installed.
- Be sure there is sufficient extra water supply line and drain line for the appliance to be pulled out for service.
- Drain line should not be piped directly to the sewer system. An air gap of a minimum of 2 vertical inches (5 cm) must be between the end of the drain pipe from the appliance and the floor drain.



- For gravity drain installation, drain must have 1/4" fall per foot (2 cm per 1 m) on horizontal runs to get good flow. A vented tee connection is also required for proper flow. Extend the vent at least 12" (30 cm) above the drain outlet.
- For optional drain pump installation, refer to the instructions included with the pump.



## G. Final Checklist

### **WARNING**

**CHOKING HAZARD:** Ensure all components, fasteners, and thumbscrews are securely in place after installation. Make sure that none have fallen into the storage bin.

- 1) Is the appliance level?
- 2) Is the appliance in a site where the ambient temperature is within 45°F to 100°F (7°C to 38°C) and the water temperature within 45°F to 90°F (7°C to 32°C) all year around?
- 3) Have the shipping carton, tape, and packing material been removed from the appliance? Has the protective plastic film been removed from the panels?
- 4) Have all electrical and water connections been made? Do electrical and water connections meet all national, state, and local code and regulation requirements?
- 5) Has the power supply voltage been checked or tested against the nameplate rating? Is the power supply a properly grounded, independent 3-prong wall outlet?
- 6) Are the water supply and drain lines sized as specified? Are the water supply line shut-off valve and drain valve installed? Has the water supply pressure been checked to ensure a minimum of 7 PSIG and a maximum of 113 PSIG?
- 7) Are all components, fasteners, and thumbscrews securely in place?
- 8) Has the end user been given this instruction manual, and instructed on how to operate the appliance and the importance of the recommended periodic maintenance?
- 9) Has the end user been given the name and telephone number of an authorized service agent?
- 10) Has the warranty tag been filled out and forwarded to the factory for warranty registration?

---

### III. Operating Instructions

#### A. Important Notes About Usage

##### **WARNING**

- Only qualified service technicians should install and service the appliance.
- Failure to install, operate, and maintain the equipment in accordance with this manual will adversely affect safety, performance, component life, and warranty coverage.
- To reduce the risk of electric shock, do not touch the control switch or plug with damp hands. Make sure the control switch is in the "OFF" position before plugging in or unplugging the appliance.
- The appliance must be maintained in accordance with the instruction manual and labels provided with the appliance. Consult with your local Hoshizaki Certified Service Representative about maintenance service.
- The appliance must be cleaned and sanitized at least twice a year. More frequent cleaning and sanitizing may be required in some water conditions.
- Wash your hands before removing ice. Use the plastic scoop provided.
- Do not place fingers or any other objects into the ice discharge opening.
- The appliance is not intended for use by persons (including children) with reduced physical, sensory, or mental capabilities, or lack of experience and knowledge, unless they have been given supervision or instruction concerning use of the appliance by a person responsible for their safety.
- Young children should be properly supervised around the appliance.
- Do not climb, stand, or hang on the appliance or appliance door or allow children or animals to do so. Serious injury could occur or the appliance could be damaged.
- Be careful not to pinch fingers when opening and closing the door. Be careful when opening and closing the door when children are in the area.
- Do not use combustible spray or place volatile or flammable substances near the appliance. They might catch fire.
- Keep the area around the appliance clean. Dirt, dust, or insects in the appliance could cause harm to individuals or damage to the appliance.

## **NOTICE**

- Protect the floor when moving the appliance to prevent damage to the floor.
- If using the optional drain pump (HS-5061), test its operation every time the appliance is cleaned and sanitized. See "IV.E. Optional Drain Pump HS-5061" for details. If the optional drain pump is not operating properly, water could back up and overflow, leading to costly water damage.
- To help ensure the storage bin drain remains clear, follow the instructions in "IV.C. Storage Bin Drain" once every 3 months or as often as necessary for conditions. If the storage bin drain becomes clogged, water could build up in the bin and overflow, leading to costly water damage.
- If water collects in the bin and will not drain, turn off the appliance and close the water supply line shut-off valve. Call for service.
- If water seeps from the base of the appliance, turn off the appliance and close the water supply line shut-off valve. Call for service. Failure to do so could lead to costly water damage.
- Do not leave the appliance on during extended periods of non-use, extended absences, or in sub-freezing temperatures. To properly prepare the appliance for these occasions, follow the instructions in "V. Preparing the Appliance for Periods of Non-Use."
- Keep ventilation openings, in the appliance enclosure or in the built-in structure, clear of obstruction.
- Do not place objects on top of the appliance.
- The storage bin is for ice use only. Do not store anything else in the storage bin.

If ice is not used on a regular basis, it may bond together in the storage bin. In this case, discard the bonded ice and allow the appliance to make fresh ice.

## B. Startup

### **⚠ WARNING**

All parts are factory-adjusted. Improper adjustments may adversely affect safety, performance, component life, and warranty coverage.

### **NOTICE**

- If the appliance is turned off, wait for at least 3 minutes before restarting the appliance to prevent damage to the compressor.
- At startup, confirm that all internal and external connections are free of leaks.

- 1) Open the water supply line shut-off valve.
- 2) Make sure the control switch is in the "OFF" position. Plug the appliance into the electrical outlet. **WARNING! To reduce the risk of electric shock, do not touch the control switch or plug with damp hands. If you have to slide the appliance back for a built-in installation, make sure you do not damage or pinch the water supply line, drain line, or power cord.**
- 3) If required by sanitation code in your area, seal the perimeter where the appliance touches the floor with approved caulk compound in a smooth and easily cleanable manner.
- 4) Move the control switch to the "ICE" position to start the automatic icemaking process.
- 5) Once the appliance starts to produce ice, allow it to run for another 30 minutes.
- 6) Move the control switch to the "OFF" position.
- 7) Remove the ice produced, then clean the storage bin liner, door liner, and door gasket using a neutral cleaner. Rinse thoroughly after cleaning.
- 8) Move the control switch to the "ICE" position to start the automatic icemaking process.
- 9) To confirm bin control operation, hold ice in contact with the bin control thermostat bulb. If the icemaker does not stop within 10 seconds, the bin control thermostat must be adjusted. Installations at higher altitude locations are more likely to require adjustment.

---

## IV. Maintenance

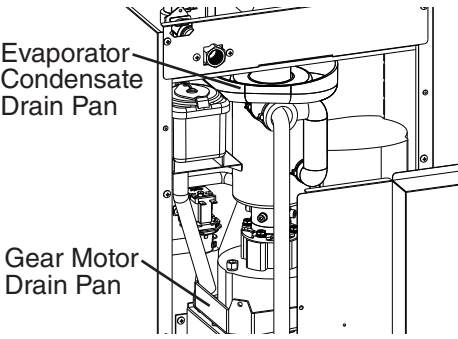
The appliance must be maintained in accordance with the instruction manual and labels provided with the appliance. Consult with your local Hoshizaki Certified Service Representative about maintenance service. To obtain the name and phone number of your local Hoshizaki Certified Service Representative, visit [www.hoshizaki.com](http://www.hoshizaki.com).

### **WARNING**

- Only qualified service technicians should service the appliance.
- Failure to install, operate, and maintain the equipment in accordance with this manual will adversely affect safety, performance, component life, and warranty coverage.
- To reduce the risk of electric shock, do not touch the control switch or plug with damp hands. Make sure the control switch is in the "OFF" position before plugging in or unplugging the appliance.
- Move the control switch to the "OFF" position and unplug the appliance from the electrical outlet before servicing.
- **CHOKING HAZARD:** Ensure all components, fasteners, and thumbscrews are securely in place after any maintenance is done to the appliance. Make sure that none have fallen into the storage bin.
- Do not place fingers or any other objects into the ice discharge opening.
- After service, make sure that there are no wires pinched between the panels and appliance. Make sure you do not damage or pinch the water supply line, drain line, or power cord.

## A. Maintenance Schedule

The maintenance schedule below is a guideline. More frequent maintenance may be required depending on water quality, the appliance's environment, and local sanitation regulations.

Maintenance Schedule		
Frequency	Area	Task
Weekly	Scoop	Clean the scoop using a neutral cleaner. Rinse thoroughly after cleaning.
Monthly	Drain the Appliance	Move the control switch to the "DRAIN" position. Allow the water system to drain for 1 minute. Clear ice away from the thermostatic bin control bulb. Move the control switch to the "ICE" position. After the gear motor starts, move the control switch to the "DRAIN" position. Allow the water system to drain for 1 minute. Move the control switch to the "ICE" position to start the automatic icemaking process.
	Appliance Exterior	Wipe down with clean, soft cloth. Use a damp cloth containing a neutral cleaner to wipe off oil or dirt build up. Clean any chlorine staining (rust colored spots) using a non-abrasive cleanser.
Every 3 Months	Storage Bin Drain	Maintain as outlined in "IV.C. Storage Bin Drain."
Every 6 Months	Ice maker and Storage Bin	Clean and sanitize per the cleaning and sanitizing instructions provided in this manual. See "IV.B. Cleaning and Sanitizing Instructions."
	Evaporator Condensate Drain Pan and Gear Motor Drain Pan	Wipe down with clean cloth and warm water. 
	Optional Drain Pump (HS-5061)	Test as outlined in "IV.E. Optional Drain Pump HS-5061."
	External Water Filters	Check for proper pressure and change if necessary.
Yearly	Water Supply Inlet	Close the water supply line shut-off valve and drain the water system. Clean the water supply inlet screen.
	Condenser	Inspect. Clean if necessary. See "IV.D. Condenser."
	Water Hoses	Inspect the water hoses and clean/replace if necessary.
	Upper Bearing (extruding head)	Check for wear using .02" round stock or pin gauge. Replace both upper bearing and lower bearing if wear exceeds factory recommendations. See the Service Manual for details.
After 3 Years, then Yearly	Upper Bearing (extruding head); Lower Bearing and O-Ring (lower housing); Mechanical Seal; Evaporator Cylinder; Auger	Inspect. Replace both upper bearing and lower bearing if wear exceeds factory recommendations. Replace the mechanical seal if the seal's contact surfaces are worn, cracked, or scratched.

## B. Cleaning and Sanitizing Instructions

The appliance must be cleaned and sanitized at least twice a year. More frequent cleaning and sanitizing may be required in some conditions.

### ⚠ WARNING

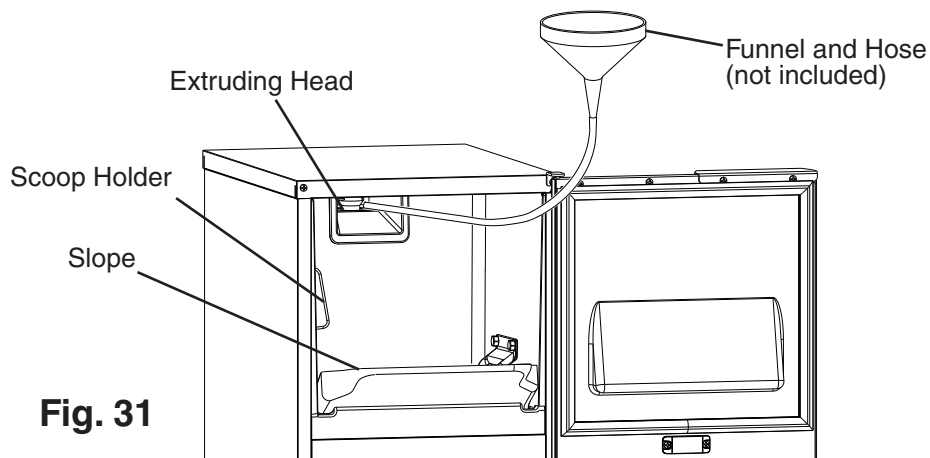
- To prevent injury to individuals and damage to the appliance, do not use ammonia type cleaners.
- Carefully follow any instructions provided with the cleaning and sanitizing solutions.
- Always wear liquid-proof gloves and goggles to prevent the cleaning and sanitizing solutions from coming into contact with skin or eyes.
- Do not use ice made from the cleaning and sanitizing solutions. After cleaning and sanitizing, be careful not to leave any solution in the appliance.
- Do not place fingers or any other objects into the ice discharge opening (extruding head).

### 1. Cleaning Solution

Dilute 1.6 fl. oz. (47 ml or 3.2 tbs) of Hoshizaki "Scale Away" or Nu-Calgon "Liquid Ice Machine Cleaner" with 1 qt (1 l) of warm water. This is a minimum amount. Make more solution if necessary. **IMPORTANT! For safety and maximum effectiveness, use the solution immediately after dilution.**

### 2. Cleaning Procedure

- 1) Move the control switch to the "OFF" position.
- 2) Remove all ice from the storage bin.
- 3) Move the control switch to the "DRAIN" position.
- 4) Allow the water system to drain for 1 minute.
- 5) Move the control switch to the "OFF" position.
- 6) Using a clean funnel and hose (not included), pour 1 qt (1 l) of cleaning solution over the extruding head. See Fig. 31. Allow the appliance to sit for 10 minutes before operation.





- 7) Make sure at least 10 minutes have elapsed since you poured the cleaning solution over the extruding head, then move the control switch to the "ICE" position.
- 8) Allow the appliance to make ice for 20 minutes, then move the control switch to the "DRAIN" position.
- 9) Allow the water system to drain for 1 minute.
- 10) Move the control switch to the "ICE" position.
- 11) After the gear motor starts, move the control switch to the "DRAIN" position.
- 12) Allow the water system to drain for 1 minute.
- 13) Move the control switch to the "OFF" position. In severe water conditions, repeat the cleaning procedure.

Note: If you do not sanitize the appliance, go to step 8 in "IV.B.5. Sanitizing Procedure - Final."

### 3. Sanitizing Solution

Dilute 1.25 fl. oz. (37 ml or 2.5 tbs) of a 5.25% sodium hypochlorite solution (chlorine bleach) with 2.5 gallons (9.5 l) of warm water. This is a minimum amount. Make more solution if necessary. Using a chlorine test strip or other method, confirm that you have a concentration of about 200 ppm. **IMPORTANT! For safety and maximum effectiveness, use the solution immediately after dilution.**

### 4. Sanitizing Procedure - Initial

- 1) Using a clean funnel and hose, pour 1 qt (1 l) of sanitizing solution over the extruding head. Allow the appliance to sit for 10 minutes before operation.
- 2) Remove the slope from the storage bin by carefully bending it in the center and releasing it from the 2 slope shafts.
- 3) Remove the scoop. Remove the 2 thumbscrews securing the scoop holder, then remove it.
- 4) Pour some of the sanitizing solution into a separate, clean container. Using this sanitizing solution and a clean cloth, wipe down the slope, scoop, scoop holder, inside of the spout, and bin liner.
- 5) Rinse the parts and areas sanitized in step 4 thoroughly with clean water.
- 6) Replace all removed parts in their original and correct positions. **WARNING! CHOKING HAZARD: Ensure all components, fasteners, and thumbscrews are securely in place. Make sure that none have fallen into the storage bin.**
- 7) Make sure at least 10 minutes have elapsed since you poured the sanitizing solution over the extruding head, then move the control switch to the "ICE" position.
- 8) Allow the appliance to make ice for 20 minutes, then move the control switch to the "DRAIN" position.
- 9) Allow the water system to drain for 1 minute.
- 10) Move the control switch to the "ICE" position.
- 11) After the gear motor starts, move the control switch to the "DRAIN" position.
- 12) Allow the water system to drain for 1 minute.
- 13) Move the control switch to the "OFF" position.

## 5. Sanitizing Procedure - Final

- 1) Using a clean funnel and hose, pour 1 qt (1 l) of sanitizing solution over the extruding head. Allow the appliance to sit for 10 minutes before operation.
- 2) Move the control switch to the "ICE" position.
- 3) Allow the appliance to make ice for 20 minutes, then move the control switch to the "DRAIN" position.
- 4) Allow the water system to drain for 1 minute.
- 5) Move the control switch to the "ICE" position.
- 6) After the gear motor starts, move the control switch to the "DRAIN" position.
- 7) Allow the water system to drain for 1 minute.
- 8) Move the control switch to the "ICE" position and allow the appliance to run. Check for leaks.
- 9) After 30 minutes, move the control switch to the "OFF" position.
- 10) Pour warm water into the storage bin to melt all of the ice, then clean the storage bin liner, door liner, and door gasket with a neutral cleaner. Rinse thoroughly after cleaning.
- 11) Move the control switch to the "ICE" position to start the automatic icemaking process.

## C. Storage Bin Drain

In some conditions, slime may build up inside the storage bin drain and prevent water from draining properly. To prevent this buildup, perform the following procedure once every 3 months or as often as necessary for conditions.

<b>NOTICE</b>
If the storage bin drain becomes clogged, water could build up in the bin and overflow, leading to costly water damage.

- 1) Move the control switch to the "OFF" position. **WARNING! To reduce the risk of electric shock, do not touch the control switch with damp hands.**
- 2) Remove all ice from the storage bin.
- 3) Mix a batch of sanitizing solution by diluting 1.25 fl. oz. (37 ml or 2.5 tbs) of a 5.25% sodium hypochlorite solution (chlorine bleach) with 2.5 gallons (9.5 l) of warm water. Using a chlorine test strip or other method, confirm that you have a concentration of about 200 ppm. **IMPORTANT! For safety and maximum effectiveness, use the solution immediately after dilution.**
- 4) Slowly pour the sanitizing solution into the storage bin.
- 5) After all of the solution has drained, clean the storage bin liner with a neutral cleaner. Rinse thoroughly with clean water.
- 6) Move the control switch to the "ICE" position to start the automatic icemaking process.

## D. Condenser

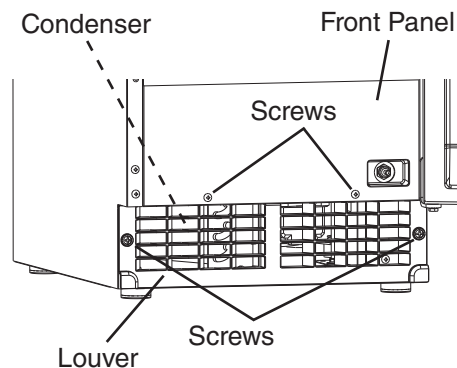
Check the condenser once a year, and clean if required by following the steps below. More frequent cleaning may be required depending on location.

### **⚠ WARNING**

Condenser fins are sharp. Use care when cleaning.

- 1) Move the control switch to the "OFF" position, then unplug the appliance from the electrical outlet. **WARNING! To reduce the risk of electric shock, do not touch the control switch or plug with damp hands.**
- 2) Remove the screws securing the front panel, then remove it. See Fig. 32.
- 3) Remove the screws securing the louver, then remove it.
- 4) Use a brush attachment on a vacuum cleaner to gently clean the condenser fins. Do not use too much force, otherwise the fins could be damaged.
- 5) Replace the louver and front panel in their correct positions. Ensure that the screws are securely in place.
- 6) Plug the appliance back in. Move the control switch to the "ICE" position to start the automatic icemaking process.

**Fig. 32**



## E. Optional Drain Pump HS-5061

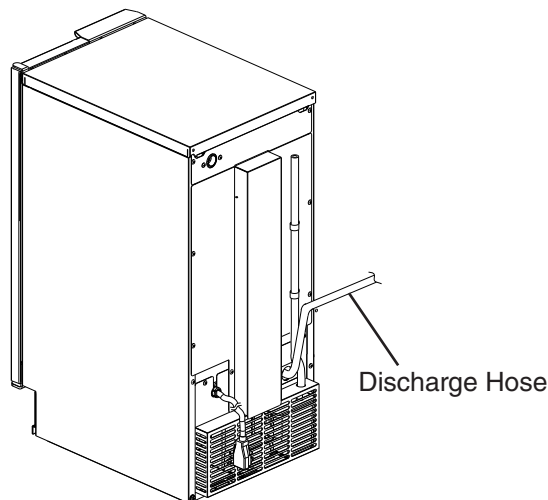
If the optional drain pump (HS-5061) is installed, test its operation at least twice a year as outlined below. Note that the pump has power even when the control switch is in the "OFF" position.

### **NOTICE**

If the optional drain pump is not operating properly, it will adversely affect performance, component life, and warranty coverage and may result in costly water damage.

- 1) Move the control switch to the "OFF" position, then unplug the appliance from the electrical outlet. **WARNING! To reduce the risk of electric shock, do not touch the control switch or plug with damp hands.**
- 2) Remove all ice from the storage bin.
- 3) Plug the appliance back in.
- 4) Slowly pour 24 to 30 oz. (710 to 890 ml) of water over the storage bin drain hole in the storage bin.
- 5) If water pumps out properly and the drain pump then de-energizes, proceed to step 6. If water does not pump out properly and/or the drain pump does not de-energize, the appliance must be serviced by a qualified service technician before proceeding.
- 6) Move the control switch to the "ICE" position.
- 7) Pour another 24 to 30 oz. (710 to 890 ml) of water into the appliance's ice storage bin, then completely restrict the discharge hose while the drain pump is operating. See Fig. 33. Pour more water into the appliance's ice storage bin until the appliance turns off. The drain pump will continue to operate. Check for leaks.
- 8) Remove the discharge hose restriction and allow the water to be pumped out normally. Power to the appliance will be restored when the water in the drain pump returns to a normal level.
- 9) If the appliance fails to turn off with the discharge hose restricted or the pump fails to pump out the water, the appliance must be serviced by a qualified service technician.

**Fig. 33**



## V. Preparing the Appliance for Periods of Non-Use

During extended periods of non-use, extended absences, or in sub-freezing temperatures, follow the instructions below. When the appliance is not used for two or three days under normal conditions, it is sufficient to move the control switch to the "OFF" position.

### **⚠ WARNING**

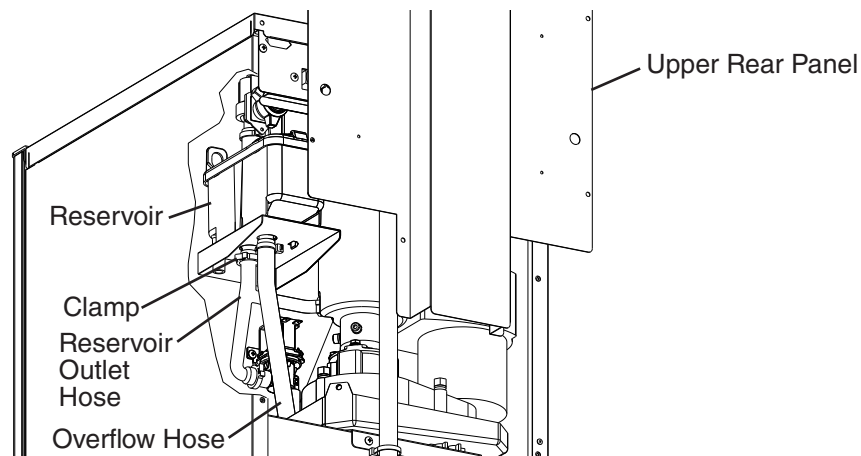
Only qualified service technicians should service the appliance.

### **NOTICE**

During extended periods of non-use, extended absences, or in sub-freezing temperatures, follow the instructions below to reduce the risk of costly water damage.

- 1) Move the control switch to the "OFF" position. **WARNING! To reduce the risk of electric shock, do not touch the control switch or plug with damp hands.**
- 2) Close the water supply line shut-off valve, then open the water supply line drain valve.
- 3) Allow the line to drain by gravity.
- 4) Move the control switch to the "DRAIN" position.
- 5) Allow the water system to drain for 1 minute.
- 6) Attach a compressed air or carbon dioxide supply to the water supply line drain valve.
- 7) Move the control switch to the "ICE" position.
- 8) Blow the water supply line out using the compressed air or carbon dioxide supply.
- 9) Close the water supply line drain valve.
- 10) Move the control switch to the "OFF" position, then unplug the appliance from the electrical outlet.
- 11) Remove the screws securing the upper rear panel, then remove it. See Fig. 34.
- 12) Remove the clamp securing the reservoir outlet hose to the reservoir. Disconnect the reservoir outlet hose from the reservoir.
- 13) Attach a compressed air or carbon dioxide supply to the reservoir outlet hose.

**Fig. 34**



- 14) Plug the appliance back in, then move the control switch to the "DRAIN" position.
- 15) Blow out the reservoir outlet hose using the compressed air or carbon dioxide supply.
- 16) Move the control switch to the "OFF" position, then unplug the appliance from the electrical outlet.
- 17) Reconnect the reservoir outlet hose to the reservoir, then secure with the clamp. Make sure all hoses are connected and secure.
- 18) Replace the rear panel in its correct position.
- 19) Clean the storage bin by using a neutral cleaner. Rinse thoroughly after cleaning.

---

## **VI. Disposal**

The appliance contains refrigerant and must be disposed of in accordance with applicable national, state, and local codes and regulations. Refrigerant must be recovered by properly certified service personnel.

**HOSHIZAKI AMERICA, INC.**

---

618 Hwy. 74 S., Peachtree City, GA 30269 USA | TEL (770) 487-2331 | FAX (770) 487-3360 | [www.hoshizaki.com](http://www.hoshizaki.com) | 1A3094-010



# Hoshizaki Drain Pump Kit for Undercounter Icemaker HS-5061

**For Use with the Following Hoshizaki Icemakers:  
AM-50 Series, C-100 Series, KM-61BAH, and KM-101BAH**

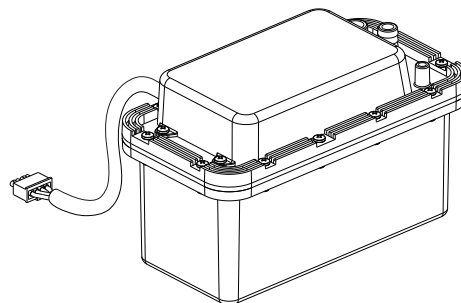
**Note: For KM-61BAH and KM-101BAH units, use the installation instructions provided with the icemaker.**

Check to ensure that all parts are included:

Index No.	Description	Qty
1	Drain Pump Assembly	1
2	Vinyl Hose (drain hose) (5/8" ID×6.5")	1
3	Vinyl Hose (vent hose) (3/8" ID×27.5")	1
4	High Pressure Clear PVC Hose (discharge hose) (1/2" ID×10')	1
5	Small Clamp (vent hose to drain pump)	1
6	Medium Clamp (discharge hose to drain pump)	1
7	Large Clamp (drain hose/drain elbow to icemaker and drain pump)	2
8	Hose Clips (vent hose)	2
8a	Truss Head Screw (4×8, SS)	2

## ⚠ WARNING

- Only qualified service technicians should install and service this drain pump to reduce the risk of death, electric shock, serious injury, or fire. A plumbing permit and the services of a licensed plumber may be required in some areas. To obtain the name and phone number of your local Hoshizaki Certified Service Representative, visit [www.hoshizaki.com](http://www.hoshizaki.com).
- No installation or service should be undertaken until the technician has thoroughly read these instructions. Failure to install, operate, and maintain this drain pump in accordance with these instructions will adversely affect safety, performance, component life, and warranty coverage and may result in costly water damage.
- Proper installation is the responsibility of the installer. Product failure or property damage due to improper installation is not covered under warranty.
- See the instruction manual provided with the icemaker for icemaker installation. Failure to install the icemaker within these guidelines may adversely affect safety, performance, component life, and warranty coverage.
- Clean, sanitize, and maintain the icemaker per the instructions provided in the icemaker's instruction manual. If the instruction manual is not available, consult with your local distributor, visit [www.hoshizaki.com](http://www.hoshizaki.com), or call Hoshizaki Technical Support at 1-800-233-1940 in the USA.
- **THE ICEMAKER MUST BE GROUNDED:** The icemaker is equipped with a 3-prong grounding plug to reduce the risk of potential shock hazards. It must be plugged into a properly grounded, independent 3-prong wall outlet. If the outlet is a 2-prong outlet, it is your personal responsibility to have a qualified electrician replace it with a properly grounded, independent 3-prong wall outlet. Do not remove the ground prong from the power cord and do not use an adapter plug.
- The icemaker and this kit must be installed in accordance with applicable national, state, and local codes and regulations.
- Protect the floor when moving the icemaker to prevent damage to the floor.
- This drain pump is approved for use only with the models listed.



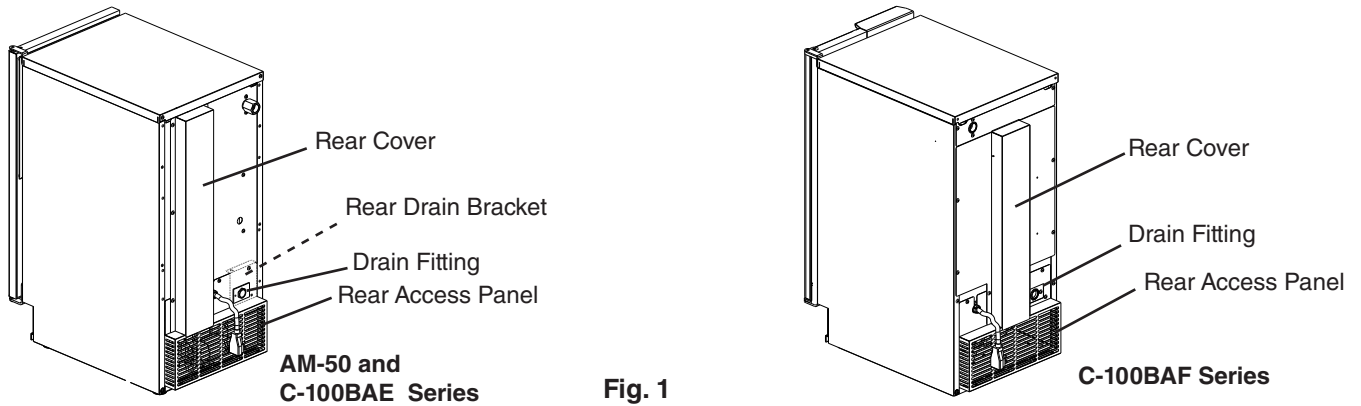
**Hoshizaki Drain Pump**

## Installation Instructions

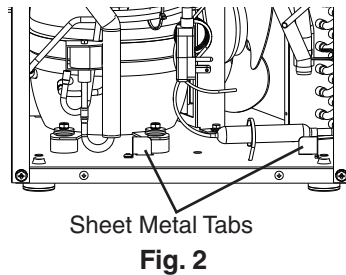
This drain pump is designed to remove drain water from an undercounter icemaker in areas without direct drainage access. The drain pump reservoir collects drain water and pumps it through a 1/2" ID high pressure clear pvc hose (discharge hose). The maximum discharge hose length is 20 feet. The maximum lift height is 8 feet. There is a factory installed check valve on the drain pump.

**NOTICE! Do not install any additional check valves.**

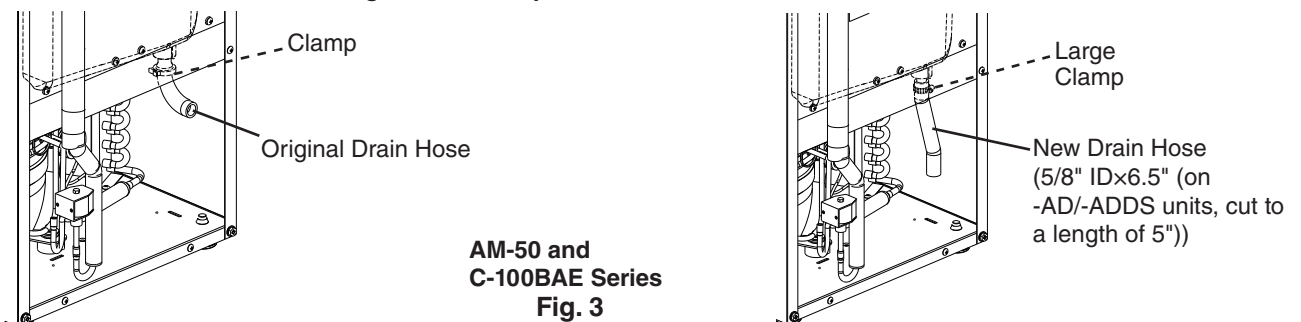
- 1) Move the control switch (AM-50 series) or power switch (C-100 series) to the "OFF" position and unplug the unit from the electrical outlet.
- 2) Remove the rear access panel and rear cover. See Fig. 1. On AM-50 and C-100BAE series, disconnect the drain hose and remove the rear drain bracket and drain fitting. On C-100BAF series, disconnect the drain hose and remove the drain fitting.



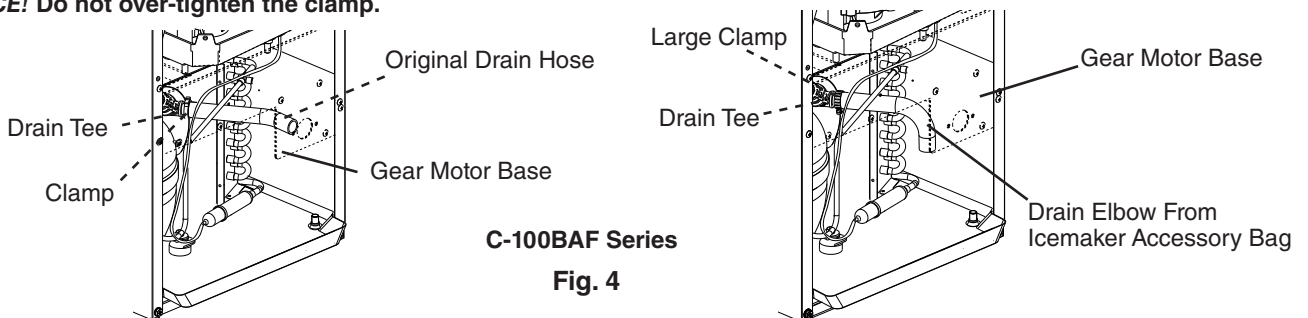
- 3) If sheet metal tabs are present on your unit, remove them. See Fig. 2.



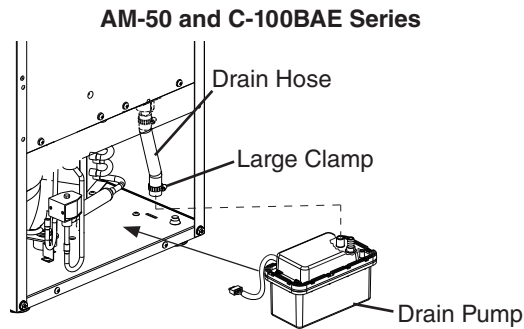
- 4a) On AM-50 and C-100BAE series, remove the original drain hose and install the new drain hose (5/8" ID×6.5") provided in this kit. See Fig. 3. On -AD/-ADDS units, cut the new drain hose to a length of 5". Secure the new drain hose with one of the large clamps provided in this kit. **NOTICE! Do not over-tighten the clamp.**



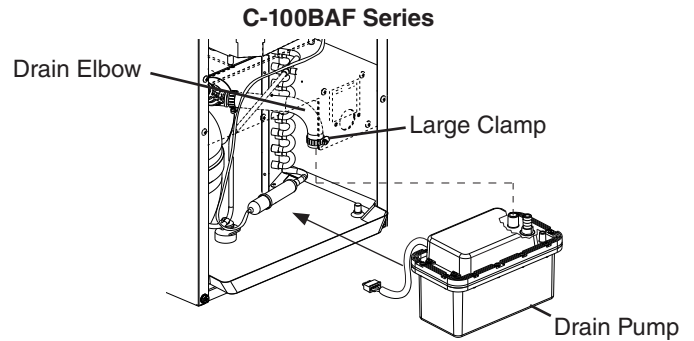
- 4b) On C-100BAF series, remove the original drain hose from the drain tee and connect the drain elbow from the icemaker accessory bag (part number 4A1165-11) to the drain tee. See Fig. 4. Secure the drain elbow with one of the large clamps provided in this kit. **NOTICE! Do not over-tighten the clamp.**



- 5) Carefully place the drain pump into the open space provided at the rear of the icemaker. The drain pump will overhang the base slightly. See Figs. 5 and 6. If necessary, carefully bend or move the icemaker's copper tubing so that it does not make contact with the drain pump, hoses, or other parts of the icemaker. **NOTICE! Drain pump MUST be level.**
- 6) Connect the drain hose/drain elbow to the drain pump as illustrated in Figs. 5 and 6. Secure the drain hose/drain elbow with the remaining large clamp provided in this kit. **NOTICE! Do not over-tighten the clamp.**

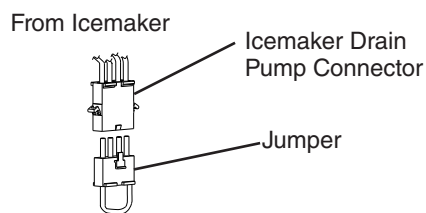


**Fig. 5**

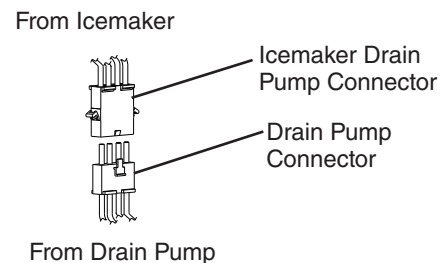


**Fig. 6**

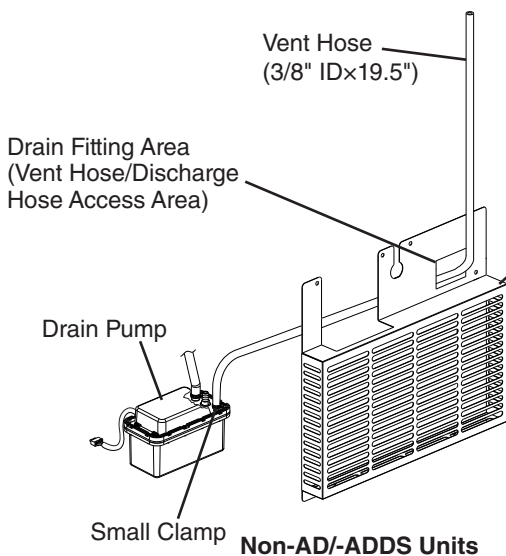
- 7) Remove the jumper plug from the icemaker's drain pump connector. See Fig. 7. The jumper plug is not needed when a drain pump is installed.
- 8) Connect the drain pump plug to the icemaker's drain pump connector.



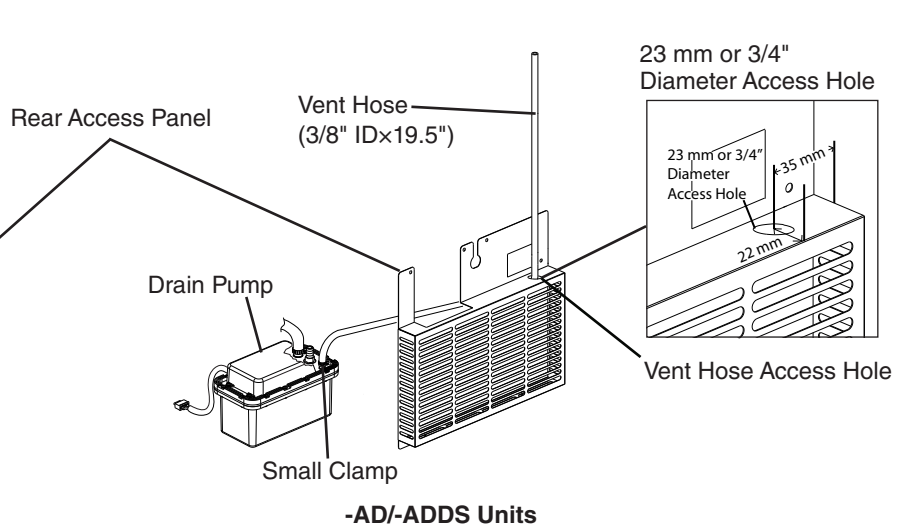
**Fig. 7**



- 9) Cut the 3/8" ID vent hose to a length of 19.5" (the full 27.5" length is for use on other models).
- 10a) On non -AD/-ADDS units, route the vent hose (3/8" ID×19.5") through the drain fitting area (vent hose/discharge hose access area) in the rear access panel. See Fig. 8.
- 10b) On -AD/-ADDS units, route the vent hose (3/8" ID×19.5") through the 23 mm diameter vent hose access hole in the rear access panel. See Fig. 9. If the rear access panel does not have a vent hose access hole, drill a 23 mm or 3/4" diameter hole into the rear access panel.
- 11) Secure the vent hose to the drain pump with the small clamp provided in this kit. **NOTICE! Do not over-tighten the clamp.**

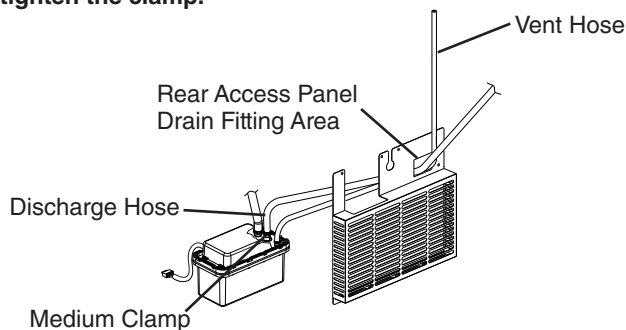


**Fig. 8**



**Fig. 9**

12a) On AM-50 and C-100BAE series, route one end of the discharge hose (1/2" ID×10') through the drain fitting area in the rear access panel. See Fig. 10. Connect the discharge hose to the drain pump. Secure the discharge hose with the medium clamp provided in this kit. **NOTICE! Do not over-tighten the clamp.**

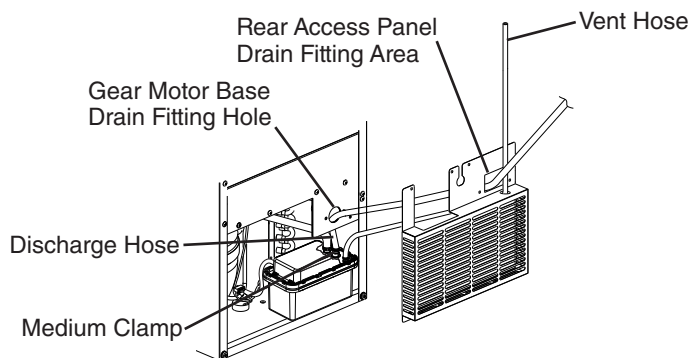


AM-50 and C-100BAE Series

Fig. 10

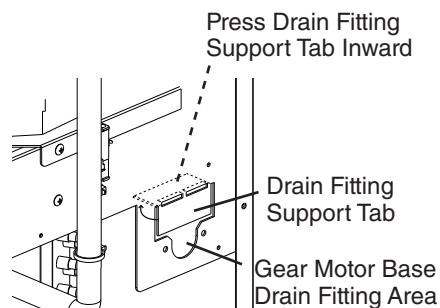
12b) On C-100BAF-AD(-ADDS) (auxiliary code V-1 and earlier), route one end of the discharge hose (1/2" ID×10') through the drain fitting area in the rear access panel, then through the gear motor base drain fitting hole. See Fig. 11. Connect the discharge hose to the drain pump. Secure the discharge hose with the medium clamp provided in this kit. **NOTICE! Do not over-tighten the clamp.**

On C-100BAF(-DS) (all auxiliary codes) and C-100BAF-AD(-ADDS) (auxiliary code V-2 and later), press the drain fitting support tab inward. See Fig. 12. Route one end of the discharge hose (1/2" ID×10') through the drain fitting area in the rear access panel, then through the gear motor base drain fitting area. Connect the discharge hose to the drain pump. Secure the discharge hose with the medium clamp provided in this kit. **NOTICE! Do not over-tighten the clamp.**



C-100BAF-AD(-ADDS)  
(Auxiliary Code V-1 and Earlier)

Fig. 11

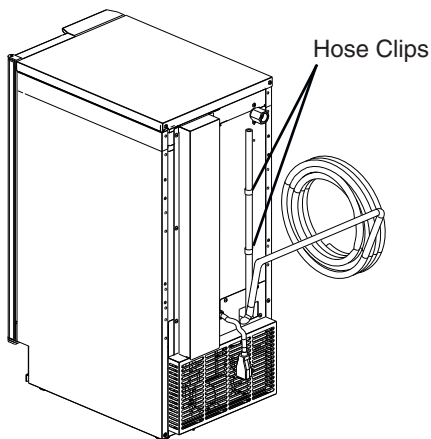


C-100BAF(-DS) (All Auxiliary Codes) and  
C-100BAF-AD(-ADDS) (Auxiliary Code V-2 and Later)

Fig. 12

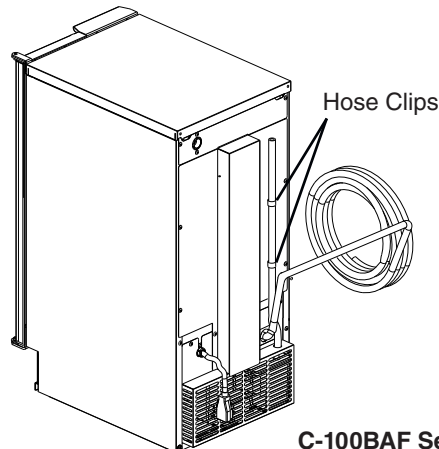
13) Reinstall the rear cover and rear access panel in their correct positions. See Fig. 13. **WARNING! Make sure that there are no wires pinched between the rear access panel, rear cover, or icemaker.**

14) Secure the vent hose to the icemaker using the two hose clips and two 4×8 truss head screws provided. See Fig. 13. Screw holes are provided. **NOTICE! The vent hose must be attached and secured to the icemaker or water damage may occur. Make certain there are no kinks in the vent hose. The drain pump will not operate correctly with a partially blocked vent hose.**



AM-50 and  
C-100BAE Series

Fig. 13



C-100BAF Series

- 15) Connect the discharge hose to a suitable drain. Do not connect the discharge hose directly to a drain pipe or a floor drain. An air gap of a minimum of 2" (5 cm) should be between the end of the discharge hose and the floor drain or drain piping. **NOTICE! Be sure there is sufficient extra tubing for the unit to be pulled out for service.** Do not allow traps or kinks in the hose that will restrict water flow. The maximum discharge hose length is 20 feet. The maximum discharge hose lift height is 8 feet. Cut excess hose as needed.
- 16) Make sure the icemaker control switch (AM-50 series) or the power switch (C-100 series) is in the "OFF" position. Plug the icemaker into the electrical outlet. **WARNING! To reduce the risk of electric shock, do not touch the control switch (AM-50 series), power switch (C-100 series), or plug with damp hands.**
- 17) Slowly pour 24 to 30 oz. (710 to 890 ml) of water over the storage bin drain hole in the storage bin.
- 18) Confirm that water is discharged through the discharge hose. The drain pump should then de-energize.
- 19) Make sure there are no water leaks.
- 20) To test the operation of the drain pump internal safety switch, move the control switch to the "ICE" position (AM-50 series) or the power switch to the "ON" position (C-100 series). Pour another 24 to 30 oz. (710 to 890 ml) of water into the icemaker's ice storage bin, then completely restrict the discharge hose while the drain pump is operating. Pour more water into the icemaker's ice storage bin until the icemaker turns off. The drain pump will continue to operate. Check for leaks. Remove the discharge hose restriction and allow the water to be pumped out normally. The power to the icemaker will be restored when the water in the drain pump returns to a normal level.
- 21) Place the icemaker in the final installation location. **WARNING! Protect the floor when moving the icemaker to prevent damage to the floor. Make sure you do not damage or pinch the water supply line, discharge tubing, drain connections, or power cord. Be sure there is sufficient extra tubing for the unit to be pulled out for service.**

### **Final Check List**

- 1) Is the drain pump level? If necessary, has the icemaker's copper tubing been carefully bent or moved so that it does not make contact with the drain pump or hoses?
- 2) Have all electrical and water connections been made per this installation manual and the instruction manual provided with the icemaker? **WARNING! To reduce the risk of electric shock, do not touch the control switch (AM-50 series), power switch (C-100 series), drain pump plug, or power cord plug with damp hands. Make sure you do not damage or pinch the inlet water supply line, drain pump discharge tubing, drain pump connections, or power cord.**
- 3) Are all water connections tight and free of leaks?
- 4) Has the drain pump been tested?
- 5) Has sufficient extra tubing been left for the unit to be pulled out for service?
- 6) Are the water supply tube, vent hose, and discharge hose free of kinks?
- 7) Has the end user been given these instructions and instructed on the importance of the recommended periodic maintenance?
- 8) Has the end user been given the name and telephone number of an authorized service agent?

## **Maintenance**

Clean, sanitize, and maintain the icemaker per the instructions provided in the icemaker's instruction manual. If the instruction manual is not available, consult with your local distributor, visit [www.hoshizaki.com](http://www.hoshizaki.com), or call Hoshizaki Technical Support at 1-800-233-1940 in the USA.

## **Troubleshooting**

- Icemaker does not run:
  - Make sure there is power at the electrical outlet.
  - Make sure the icemaker's control switch is in the "ICE" position (AM-50 series) or the power switch is in the "ON" position (C-100 series).
  - Make sure the icemaker's ice storage bin is not full.
  - Make sure the drain pump is properly connected to the icemaker.
  - The icemaker will not run if the drain pump is filled to capacity, but the drain pump will continue to operate. When the water level lowers, the icemaker will restart.
- Drain pump does not run:
  - Make sure there is power at the electrical outlet.
  - Make sure the drain pump connector is connected to the icemaker's drain pump connector.
  - Make sure the hole at the top of the drain pump inlet fitting is clear and that there is nothing blocking water flow to the drain pump. Clean as needed.
  - Make sure the vent hose is open and free of kinks and sharp bends.
  - Make sure there is enough water to activate the drain pump. It takes at least 24 oz. (710 ml) of water to activate the drain pump.
- The drain pump runs but no water is pumped out:
  - Make sure the discharge hose is free of foreign material and free of traps and kinks.
  - Make sure the discharge hose has not exceeded the maximum horizontal length of 20 feet or the maximum lift height of 8 feet.

Note: If the drain pump fails, water will remain in the drain pump and the icemaker if installed properly.

## **Warranty**

This optional Hoshizaki drain pump carries a one year parts and labor warranty. The warranty begins on the installation date of the drain pump. For warranty validation, be sure to properly register your icemaker.

## **Installer Notes**

- Leave this instruction manual along with the icemaker instruction manual and warranty information with the end user for future reference.
- Instruct the user on icemaker operation and the importance of regular maintenance.

Model Number of Icemaker: \_\_\_\_\_

Serial Number of Icemaker: \_\_\_\_\_

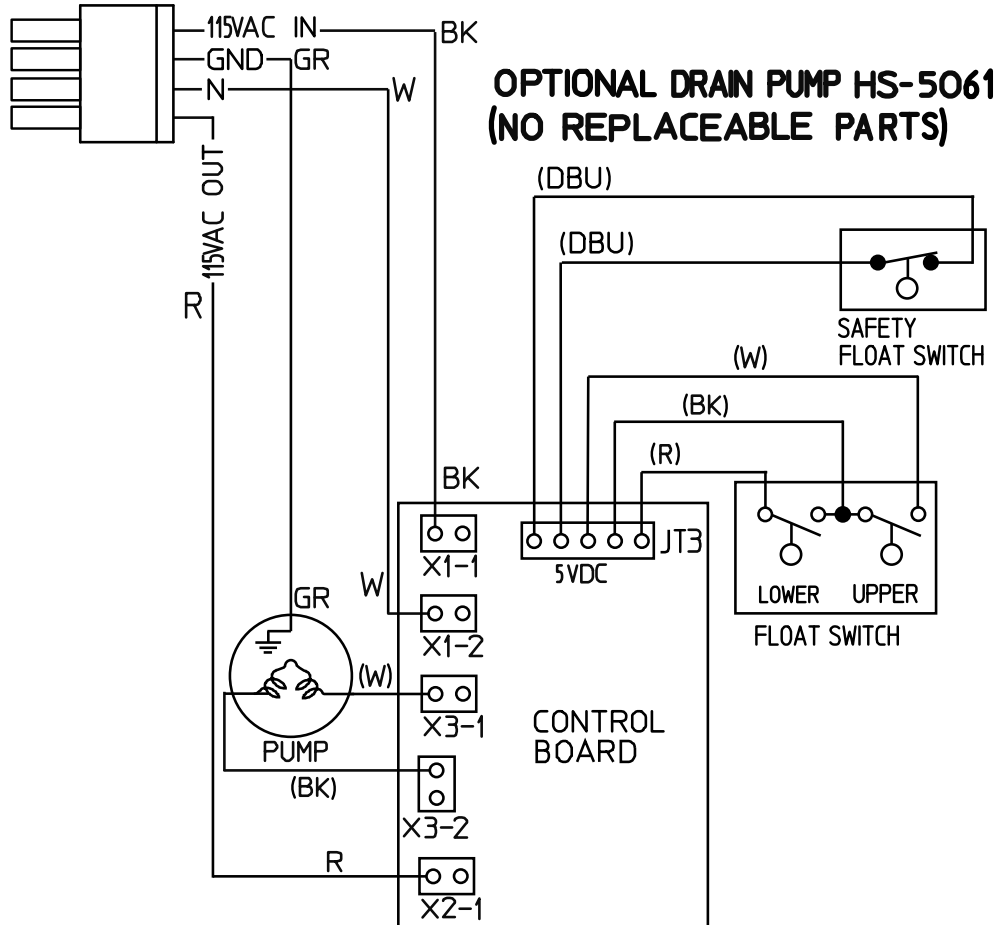
Drain Pump Installation Date: \_\_\_\_\_

## **Contact Information**

Hoshizaki America, Inc.  
618 Highway 74 South  
Peachtree City, GA. 30269  
Tel: 1-800-233-1940 - Technical Support  
E-mail: [techsupport@hoshizaki.com](mailto:techsupport@hoshizaki.com)  
Web: [www.hoshizaki.com](http://www.hoshizaki.com)

# HS-5061 Wiring Diagram

To Drain Pump  
Connector on Icemaker



## Wire Color Code

BK-BLACK  
 DBU-DARK BLUE  
 GR-GREEN  
 R-RED  
 W-WHITE

## Voltage Code

GND-GROUND  
 N-NEUTRAL