



Operators Manual

Installation, Operation & Service

Electric Floor Model Mixers

FOR UNITS BUILT AFTER JULY 2010

MODELS:

- MKEL-40-T
- MKEL-60-T
- MKEL-80-T
- MKEL-100-T
- TMKEL-40-T
- TMKEL-60-T
- TMKEL-80-T
- TMKEL-100-T



1333 East 179th St., Cleveland, Ohio, U.S.A. 44110
Ph: 216.481.4900 Fx: 216.481.3782
www.clevelandrange.com

For a complete Service Manual
refer to www.clevelandrange.com



For your safety

DANGER

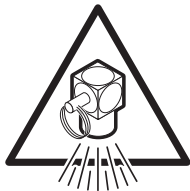

Keep clear of pressure relief discharge.



Keep hands away from moving parts and pinch points.

IMPORTANT



Inspect unit daily for proper operation.

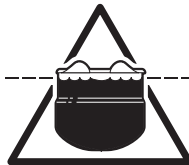

Do not fill kettle above recommended level marked on outside of kettle.

CAUTION



Surfaces may be extremely hot! Use protective equipment.



Wear protective equipment when discharging hot product.



Do not lean on or place objects on kettle lip.



Stand clear of product discharge path when discharging hot product.

SERVICING

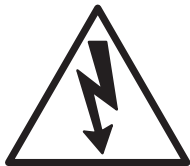

Shut off power at main fuse disconnect prior to servicing.



Ensure kettle is at room temperature and pressure gauge is showing zero or less prior to removing any fittings.

GAS APPLIANCES

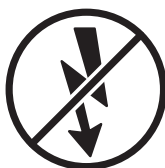

Do not attempt to operate this appliance during a power failure.



Keep appliance and area free and clear of combustibles.



Unit exhaust contains carbon monoxide. Operate only under a properly functioning hood with adequate makeup air.

INSTALLATION

GENERAL

Installation of the kettle must be accomplished by qualified electrical installation personnel working to all applicable local and national codes. Improper installation of product could cause injury or damage.

This equipment is built to comply with applicable standards for manufacturers. Included among those approval agencies are: UL, NSF, ASME/Ntl. Bd., CSA, CGA, ETL, and others. Many local codes exist, and it is the responsibility of the owner/installer to comply with these codes.

Note: Maximum voltage for LVD (low volt directive for Europe) to be 440 volts for CE marked appliances.

INSPECTION

Before unpacking visually inspect the unit for evidence of damage during shipping.

If damage is noticed, do not unpack the unit, follow Shipping Damage Instructions shown below.

SHIPPING DAMAGE INSTRUCTIONS

If shipping damage to the unit is discovered or suspected, observe the following guidelines in preparing a shipping damage claim.

1. Write down a description of the damage or the reason for suspecting damage as soon as it is discovered. This will help in filling out the claim forms later.
2. As soon as damage is discovered or suspected, notify the carrier that delivered the shipment.
3. Arrange for the carrier's representative to examine the damage.
4. Fill out all carrier claims forms and have the examining carrier sign and date each form.

INSTALLATION

The first installation step is to refer to the Specification Sheets or Specification Drawings for detailed clearance and drain requirements in order to determine the location of the kettle. Next, carefully cut open the shipping carton for easy removal of the kettle.

CLEARANCE REQUIREMENTS

This unit must be installed in accordance with the clearances shown on the rating label which is adhered to the unit.

FOR YOUR SAFETY. Keep the appliance area free and clear of combustible materials.

RECOMMENDED FLOOR DRAIN LOCATION

Recommended Floor Drain Location

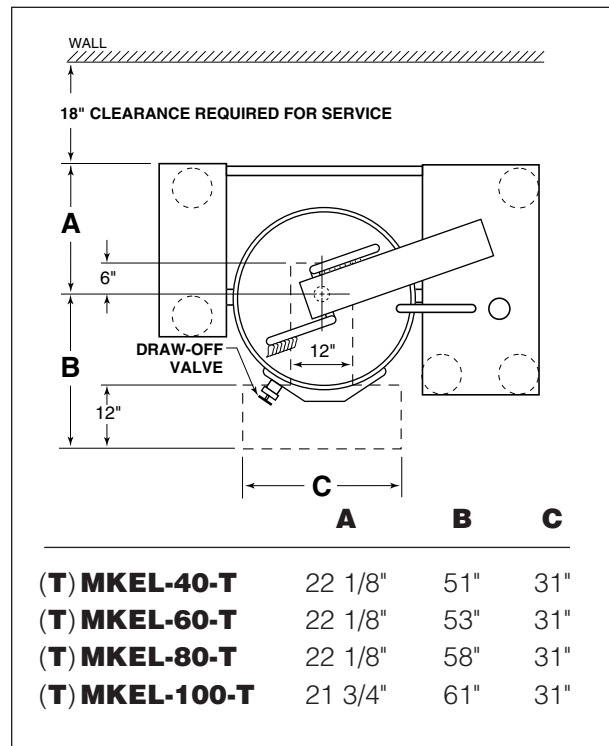

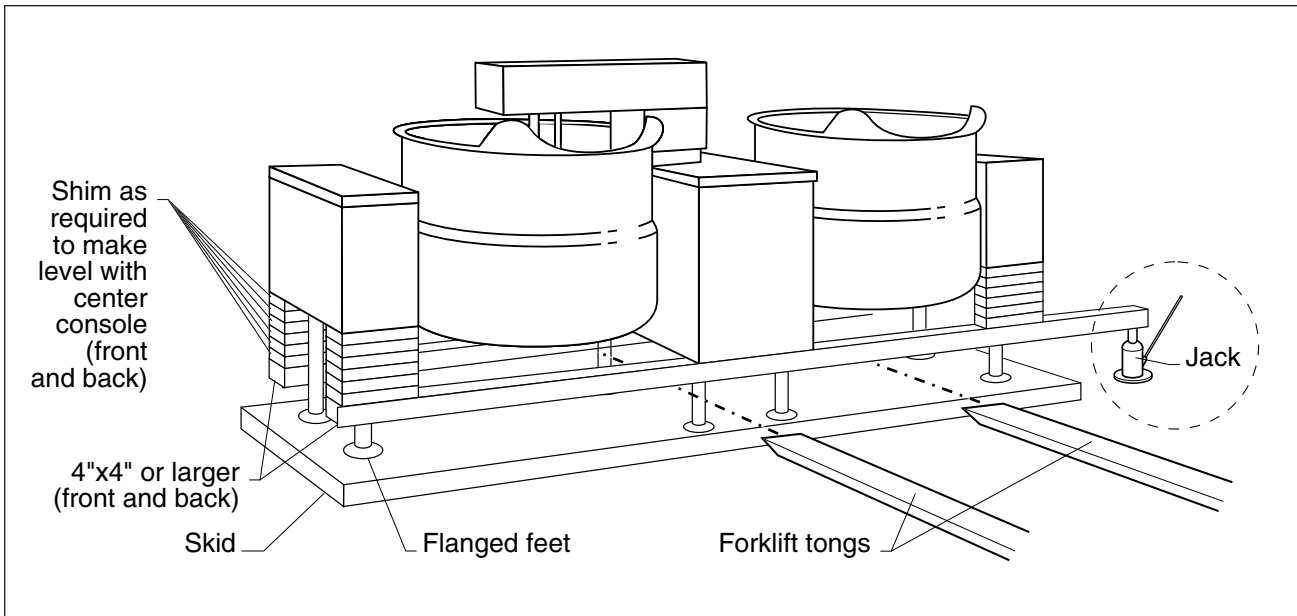

Recommended Installation Procedure

MOVING UNIT

1. While still on skid, move unit as close to final installation position as possible.
2. Prepare unit for lifting as shown in diagram.
3. Lift gently with a forklift or jacks and remove skid.
4. Lower gently to ground and remove forklift and blocking.
5. If unit has to be re-positioned, slide gently. Do not twist or push one side of unit excessively and cause binding on trunnions.

LEVELING

Note: Instructions reflect a more complicated twin mixer kettle - process for single mixer kettles is the same.

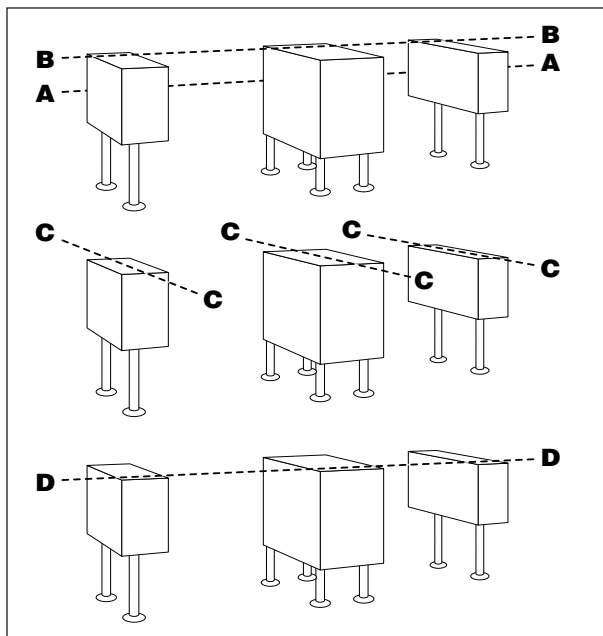

Recommended Leveling Procedure

1. With straight-edge, line the backs of the consoles up with each other (dotted line **A**).
2. Level and straight-edge backs of consoles (dotted line **B**). Adjustments are made by turning flanges on back feet only.

3. Level consoles individually from front to back (dotted lines **C**). Adjustments are made by turning flanges on front feet only.
4. Re-check that the back is level (dotted line **B**) and then the front (dotted line **D**). Adjust if necessary.

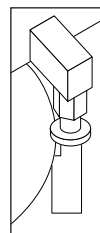

Guide Pins

5. Check that mixer bridge is level and guide pins lock smoothly without binding. If not repeat steps **1** through **4**.

NOTE: See Operating Instructions before operating unit.

6. Make electrical connections (see electrical service connections) and test mixer bridge as follows:

- ⇒ **A/** Raise mixer bridge.
- ⇒ **B/** Swing bridge out over centre console.
- ⇒ **C/** Swing bridge to the left as far as possible.

- ⇒ **D/** Lower bridge.
 - ⇒ **E/** Bridge pins should enter pin hole on kettle perfectly, If not return to step 1 and repeat leveling steps.
 - ⇒ **F/** Raise bridge and swing to far right (for twin mixers only).
 - ⇒ **G/** Repeat steps **D** and **E** (for twin mixers only).
- 7.** Once positioned and leveled, permanently secure the kettle's flanged feet to the floor using 5/16 inch stainless steel lag bolts and floor anchors (supplied by the installer). Secure each of the flanged feet with one bolt in each hole.
 - 8.** Connect piping as described in the "PIPING CONNECTION" section.

ELECTRICAL SERVICE CONNECTIONS

Install in accordance with local codes and/or the National Electric Code ANSI/NFPA No 70-1981 (USA) or the Canadian Electric Code CSA Standard C22.1 (Canada). A separate fused disconnect switch must be supplied and installed. The kettle must be electrically grounded by the installer.

The electric supply must match the power requirements specified on the kettle's rating plate. The copper wiring must be adequate to carry the required current at the rated voltage.

- 1.** Ensure main power is turned off before connecting wires.
- 2.** Remove the screws at the rear of the center console cover, and remove the cover. A wiring diagram is affixed to the underside of the console cover.
- 3.** Feed permanent copper wiring 18" through the cut-out in the bottom of the console. Connect wiring in junction box in the bottom of the console.
- 4.** Turn main power back on.
- 5.** Check for correct rotation of electric motor (access by removing top front cover on center console). If rotation is incorrect, disconnect main power and reverse any two of the three live lines.
- 6.** Replace the console cover and secure it with screws.

QUALITY ASSURANCE CHECKLIST

Follow this list only after all other installation steps are completed. Some steps require the use of equipment. Follow operating instructions.

The following will be performed before the unit is connected to utilities:

- 1.** Visual Examine unit for scratches, dents, or other defects.
- 2.** Visual Check flanged feet all have bolts holding them.
- 3.** General Check all accessible wiring, mechanical and plumbing connections by hand for secure, tight and satisfactory assembly. Remove all paper.
- 4.** Level Check unit has been leveled and squared correctly.

The following will be performed with the unit connected to utilities:

- 5.** Raise Bridge If bridge does not raise then check motor rotation. Bridge should not raise until speed control is turned to minimum and then adjusted back up.
- 6.** Swing Bridge Bridge when fully raised should swing without hitting any object, i.e. control housing, kettle lip. Check that hydraulic hoses are not being pinched by stops on swivel assembly.
- 7.** Tilt Kettle Kettle tilts smoothly both down and back up. If power tilt, check that micro switches are adjusted properly (kettle is level in upright position and drains fully when tilted) and are not being crushed by gear.
- 8.** Lower Bridge Raise bridge. Switch to mix. Turn speed control to zero to reset micro switch then set speed control to number four. Check that unit does not begin to mix until bridge has lowered part way into the kettle. Check that mixer bridge pin lowers into pin hole correctly
- 9.** Speed Control - Main Main agitator arm not rotating when set at minimum but will start to move slowly on one. Speed control makes positive contact with micro switch.
- 10.** Speed Control - Secondary Set main speed control to five. Adjust secondary control from minimum to maximum. Look for considerable speed variance.
- 11.** Water Faucets Turn on hot water faucet. Turn off and check for leaks in piping and drips from faucet spout. Repeat above with cold water faucet.
- 12.** Product Discharge Valve Add water to kettle. Check for leaks from valve. Open and close valve a few times and check for leaks again.

OPTIONAL CONTROLS

Some units may not have the following items to test

- 13. Meter** Complete this test using markings on mixer arm or a measuring strip if there are no markings on the unit. Test the meter at the following values up to capacity (Should be approx. $\pm 1/4"$). During this test check that the (interrupt) switch stops the water flow and the (continue/reset) when switched to "continue" resumes the flow without resetting the meter.

GALLONS	LITERS
5	20
20	80
40	160
80	320
100	400

When the (continue/reset) switch is turned to "reset" the displayed quantity on the meter should be erased and the count begins at zero.

INSTALLATION CHECKS

Although the kettle has been thoroughly tested before leaving the factory, the installer is responsible for ensuring the proper operation of kettle once installed.

Performance Checks

1. Supply power to the kettle by placing the fused disconnect switch to the "ON" position.
2. Before turning the kettle on, read the vacuum/pressure gauge. The gauge's needle should be in the green zone.
3. Place the kettle's power ON/OFF switch to the "ON" position.
4. Turn the temperature control knob to "1" (Min.). The green LED light should remain lit, indicating the burner is lit, until the set temperature is reached (124°F/50°C). Then the green light will cycle on and off, indicating the element is cycling on and off to maintain temperature.
5. Tilt the kettle forward (tilting models only). After a few seconds the red "LOW WATER" light should be lit when the kettle is in a tilted position. This light indicates that the element has automatically been shut off by the kettle's safety circuit. This is a normal condition when the kettle is in a tilted position.
6. Raise the kettle to the upright position (tilting models only). The red "low water" light should go out when the kettle is upright.
7. Turn the temperature control knob to "10" (Max.) and allow the kettle to preheat. The green light should remain on until the set temperature (260°F/127°C) is reached. Then the green light will cycle ON and OFF, indicating the element is cycling ON and OFF to maintain temperature. Fill the kettle with cold water to the steam jacket's welded seam.
8. When all testing is complete, empty the kettle and place the power ON/OFF switch in the "OFF" position.

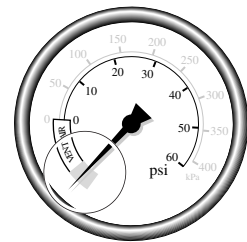

OPERATING INSTRUCTIONS

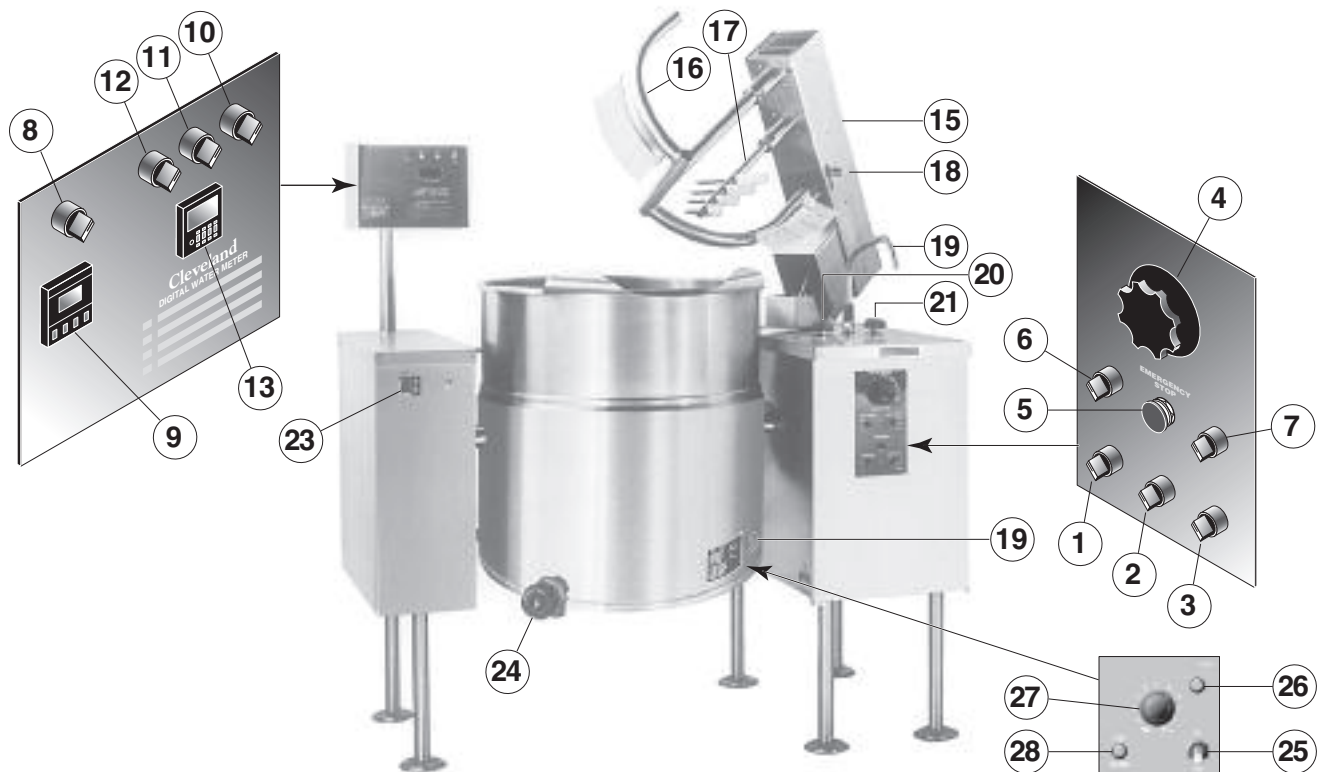

ITEM #	DESCRIPTION	FUNCTION
1	MAIN POWER SWITCH	Power switch for unit.
2	MIX/LIFT SWITCH	Sets hydraulics to mix or lift mode.
3	UP/DOWN SWITCH	When unit is in lift mode, mixer bridge can be raised or lowered with this switch.
4	MIXER SPEED CONTROL	Controls speed of agitators and mixer bridge lift.
5	EMERGENCY STOP BUTTON	Stops hydraulic system (agitators and mixer bridge lift).
6	HEAT/COOL SWITCH	Switches left hand kettle from heating to cooling.
7	HEAT/COOL SWITCH	Switches right hand kettle from heating to cooling.
8	ACTIVE/BYPASS SWITCH	Switch to activate or bypass (manual operation) the controller.
9	TEMPERATURE CONTROLLER	Digital temperature control and indicator.
10	WATER METER POWER SWITCH	Power switch for water meter.
11	WATER METER START SWITCH	Starts water flow to kettle.
12	WATER METER INTERRUPT SWITCH	Interrupts flow without resetting water meter.
13	WATER METER CONTROL	Display and settings for water meter.
15	MIXER BRIDGE	Encloses agitator motors.
16	MAIN AGITATOR ARM	Provides most of the product movement.
17	SECONDARY AGITATOR ARM	Provides reverse agitation and product lift in kettle.
18	SECONDARY SPEED CONTROL KNOB	Controls speed of secondary agitator arm.
19	FAUCET SPOUT	Delivers water to the kettle.
20	HOT WATER VALVE	Turns on hot water.
21	COLD WATER VALVE	Turns on cold water.
22	VACUUM/PRESSURE GAUGE	Indicates steam pressure in PSI inside steam jacket as well as vacuum in inches of mercury.
23	POWER TILT CONTROL SWITCH	Used for tilting the kettle up or down. Replaced by hand tilt wheel on manual tilt units.
24	DRAW OFF VALVE	Discharge valve for product in the kettle.
25	ON/OFF HEAT SWITCH	Controls electrical power (heat) to kettle.
26	HEAT INDICATOR LIGHT (GREEN)	When lit, indicates that the kettle burner is on. Cycles ON-OFF with burner.
27	SOLID STATE TEMPERATURE CONTROL KNOB	This control allows the operator to adjust the kettle temperature in increments from 1 (Min.) to 10 (Max.). (see Temperature Range Chart).
28	LOW WATER INDICATOR LIGHT	When lit, indicates that the kettle is low on water and will not operate in this (Red) condition. This will also light when the kettle is tilted.

Operating the Kettle

1. Before turning kettle on, read the Vacuum/Pressure Gauge. The gauges needle should be in the green zone. Once heated, the kettle's normal maximum operating pressure is approximately 10-12 psi, while cooking a water base product.
2. Ensure that the electrical service to the kettle is turned on at the fused disconnect switch.
3. Place the kettle's On-Off Heat Switch to the "ON" position.

Temperature Control Setting	Approximate Product Temperature	
	°F	°C
1. (Min.)	130	54
2.	145	63
3.	160	71
4.	170	77
5.	185	85
6.	195	91
7.	210	99
8.	230	110
9.	245	118
10. (Max.)	260	127
NOTE: Certain combinations of ingredients will result in temperature variations		

Temperature Range Chart

4. Preheat the kettle by turning the Solid State Temperature Control Knob to the desired temperature setting (see above "Temperature Range Chart"). The Heat Indicator Light (Green) will remain lit, indicating the burner is lit, until the temperature setting is reached. When the green light goes off, the heaters are off, and preheating is complete.

NOTE: When cooking egg and milk products, the kettle should not be preheated, as products of this nature adhere to hot cooking surfaces. These types of food should be placed in the kettle before heating is begun.

5. Place food product into the kettle. The Heat Indicator Light (Green) will cycle on and off indicating the elements are cycling on and off to maintain the set temperature.

NOTE: Do not fill kettle above recommended level marked on outside of kettle.

NOTE: The Low Water Indicator Light (Red) should not be lit when kettle is in the upright position during kettle operation. This light indicates that the elements have been automatically shut off by the kettle's safety circuit. It is, however, normal for the red light to come on when the kettle is in a tilted position.

6. When cooking is completed place On-Off Heat Switch to the "OFF" position.
7. Pour the contents of the kettle into an appropriate container by tilting the kettle forward. Care should be taken to pour slowly enough to avoid splashing off the product.

NOTE: As with cleaning food soil from any cookware, an important part of kettle cleaning is to prevent food from drying on. For this reason, cleaning should be completed immediately after cooked foods are removed.

The accompanying chart shows approximate times required for electric kettles of various capacities to boil water. Temperature control knob must be set at "10" (Max.) throughout the heatup period. Water will boil about 1/3 faster if the kettle is filled only to the outer steam jacket's welded seam, resulting in a kettle filled to 2/3 capacity.

APPROXIMATE FULL KETTLE COOKING TIMES

Gals.	Ltrs.	Times in Minutes					
		Standard Wattage			High Wattage*		
		208V	240V	480V	208V	240V	480V
25	95	60	45	60	40	30	30
40	150	60	50	75	40	30	30
60	225	100	75	75	50	40	40
80	300	130	100	100	65	50	50
100	375	160	120	120	80	60	60

* High Wattage is only available with 3 phase units

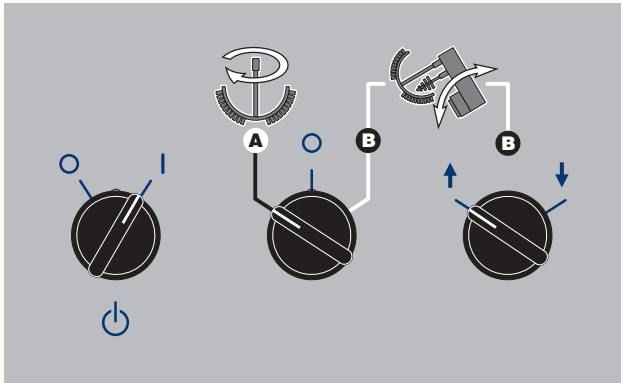

MAIN POWER SWITCH

MIX/LIFT SWITCH

UP/DOWN SWITCH

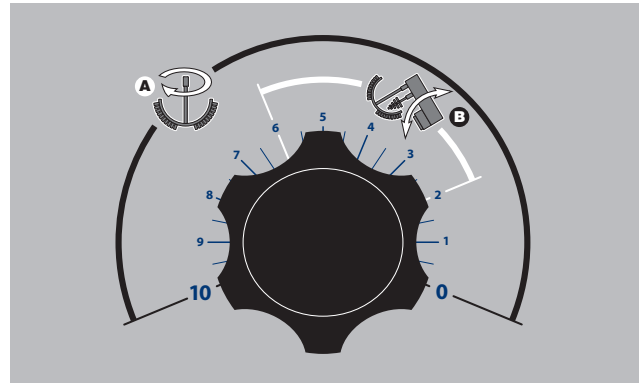

MIXER SPEED CONTROL SWITCH

Operating Suggestions

Cleveland Range Mixer Kettles are simple and safe to operate. The following tips will allow you to maximize the use of your new mixer.

- To achieve optimum performance on tilting kettles;
Before applying steam to a cold kettle, open the DRAIN COCK to drain condensate from the kettles jacket. Close drain cock when unit is fully drained.
- Allow unit to preheat before addition of product to kettle. However when cooking egg and milk products, the kettle should NOT be preheated, as products of this nature adhere to hot cooking surfaces. These types of foods should be placed in the kettle before heating is begun.
- An important part of kettle cleaning is to prevent foods from drying on. For this reason, cleaning should be completed immediately after cooked foods are removed. Refer to the "Care and Cleaning" instructions for detailed kettle washing procedures.
- If a mixer bridge is equipped with a temperature probe for a controller or thermometer, the probe must be submerged a minimum of three inches in the product for accurate readings.

Safety

- Close PRODUCT DISCHARGE VALVE before filling the kettle.
- When raising or lowering MIXER BRIDGE, insure FAUCET SPOUT is not in the way of MAIN AGITATOR ARM or damage to spout will result.
- As a safety precaution the MIXER SPEED CONTROL must first be turned to zero before unit will start to mix.
- Always remember, like a cooking pot the kettles become very hot when cooking. Avoid contact with bare skin.

General Operation

- Turn MAIN POWER SWITCH on.
- Turn STEAM CONTROL VALVE to control heat kettle.

Lifting & Lowering Bridge

WARNING: Insure FAUCET SPOUT is out of way before raising or lowering bridge.

- Turn MIX/LIFT SWITCH to lift icon "A".
- Turn MIXER SPEED CONTROL to "0" and back up to "5".
- Turn and hold UP/DOWN SWITCH to up arrow to raise or down arrow to lower.

Mixing

- Turn MIX/LIFT SWITCH to mix icon "B".
- Turn MIXER SPEED CONTROL SWITCH to "0" and slowly adjust to desired speed.
- Adjust SECONDARY SPEED CONTROL KNOB to desired speed.

Tilting Kettle

- Raise MIXER BRIDGE and swing to side.
- For manual tilt: Turn HANDWHEEL.
- For power tilt: Turn POWER TILT CONTROL SWITCH.

WARNING: Do not tilt kettle when mixer agitators are in kettle bowl.

Product Discharge Valve

- For butterfly valve: Push handle in and pull upwards to open.
- For air valve: Turn AIR REGULATOR SWITCH to open or close.

Adding Water Manually

- Locate FAUCET SPOUT over desired kettle.
- Turn on HOT or COLD WATER VALVES.



CLEANING INSTRUCTIONS



CARE AND CLEANING

Cooking equipment must be cleaned regularly to maintain its fast, efficient cooking performance and to ensure its continued safe, reliable operation. The best time to clean is shortly after each use (allow unit to cool to a safe temperature).

WARNINGS

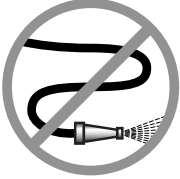
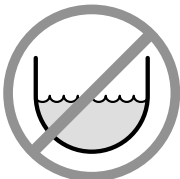
- ⇒  Do not use detergents or cleansers that are chloride based or contain quaternary salt.
Chloride Cleaners
- ⇒  Do not use a metal bristle brush or scraper.
Wire Brush &
- ⇒  Steel wool should never be used for cleaning the stainless steel.
Steel Pads
- ⇒  Unit should never be cleaned with a high pressure spray hose.
High Pressure Spray Hose
- ⇒  Do not leave water sitting in unit when not in use.
Stagnant Water

CLEANING INSTRUCTIONS

1. Turn unit off.
2. Remove drain screen (if applicable). Thoroughly wash and rinse the screen either in a sink or a dishwasher.
3. Prepare a warm water and mild detergent solution in the unit.
4. Remove food soil using a nylon brush.
5. Loosen food which is stuck by allowing it to soak at a low temperature setting.
6. Drain unit.
7. Rinse interior thoroughly.
8. If the unit is equipped with a **Tangent Draw-Off Valve**, clean as follows:
 - a) Disassemble the draw-off valve first by turning the valve knob counter-clockwise, then turning the large hex nut counter-clockwise until the valve stem is free of the valve body.
 - b) In a sink, wash and rinse the inside of the valve body using a nylon brush.
 - c) Use a nylon brush to clean tangent draw-off tube.
 - d) Rinse with fresh water.
 - e) Reassemble the draw-off valve by reversing the procedure for disassembly. The valve's hex nut should be hand tight only.
9. If the unit is equipped with a **Butterfly Valve**, clean as follows:
 - a) Place valve in open position.
 - b) Wash using a warm water and mild detergent solution.
 - c) Remove food deposits using a nylon brush.
 - d) Rinse with fresh water.
 - e) Leave valve open when unit is not in use.

- 10.** If the unit is equipped with a **Air Valve**, clean daily as follows:

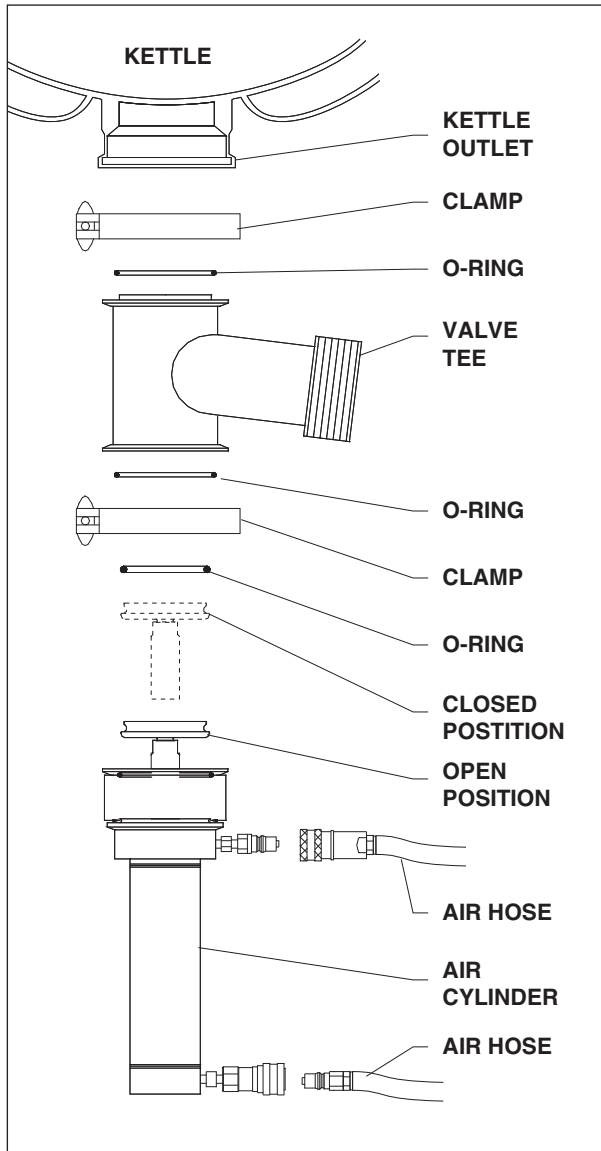

- a)** Open product valve.
- b)** Disconnect air hoses.
- c)** Remove air cylinder.
- d)** Remove valve tee.
- e)** Remove all O-rings.
- f)** Clean air cylinder, do not submerge in water. Wipe clean and sanitize.
- g)** Clean and sanitize tee and O-rings.
- h)** Grease and reinstall O-rings.
- i)** Reinstall tee to kettle outlet.
- j)** Reinstall air cylinder to bottom of tee.
- k)** Reconnect air hoses.
- l)** Close valve and check for alignment.

- 11.** Clean the scraper blades as follows:

- a)** Remove retaining ring and slide scraper blades off agitator arm.
- b)** Place parts in a pan of warm water to soak.
- c)** Clean in a sink, using a warm water and mild detergent solution.
- d)** Rinse with fresh water.
- e)** Allow to dry thoroughly on a flat, clean surface.

- 10.** Using mild soapy water and a damp sponge, wash the exterior, rinse, and dry.

NOTES

- ⇒ For more difficult cleaning applications one of the following can be used: alcohol, baking soda, vinegar, or a solution of ammonia in water.
- ⇒ Leave the cover off when the kettle is not in use.

STAINLESS STEEL EQUIPMENT CARE AND CLEANING

(Supplied courtesy of Nafem. For more information visit their web site at www.nafem.org)

Contrary to popular belief, stainless steels ARE susceptible to rusting.

Corrosion on metals is everywhere. It is recognized quickly on iron and steel as unsightly yellow/orange rust. Such metals are called "active" because they actively corrode in a natural environment when their atoms combine with oxygen to form rust.

Stainless steels are passive metals because they contain other metals, like chromium, nickel and manganese that stabilize the atoms. 400 series stainless steels are called ferritic, contain chromium, and are magnetic; 300 series stainless steels are called austenitic, contain chromium and nickel; and 200 series stainless, also austenitic, contains manganese, nitrogen and carbon. Austenitic types of stainless are not magnetic, and generally provide greater resistance to corrosion than ferritic types.

With 12-30 percent chromium, an invisible passive film covers the steel's surface acting as a shield against corrosion. As long as the film is intact and not broken or contaminated, the metal is passive and stain-less. If the passive film of stainless steel has been broken, equipment starts to corrode. At its end, it rusts.

Enemies of Stainless Steel

There are three basic things which can break down stainless steel's passivity layer and allow corrosion to occur.

1. Mechanical abrasion
2. Deposits and water
3. Chlorides

Mechanical abrasion means those things that will scratch a steel surface. Steel pads, wire brushes and scrapers are prime examples.

Water comes out of the faucet in varying degrees of hardness. Depending on what part of the country you live in, you may have hard or soft water. Hard water may leave spots, and when heated leave deposits behind that if left to sit, will break down the passive layer and rust stainless steel. Other deposits from food preparation and service must be properly removed.

Chlorides are found nearly everywhere. They are in water, food and table salt. One of the worst chloride perpetrators can come from household and industrial cleaners.

So what does all this mean? Don't Despair!

Here are a few steps that can help prevent stainless steel rust.

1. Use the proper tools.

When cleaning stainless steel products, use non-abrasive tools. Soft cloths and plastic scouring pads will not harm steel's passive layer. Stainless steel pads also can be used but the scrubbing motion must be in the direction of the manufacturers' polishing marks.

2. Clean with the polish lines.

Some stainless steel comes with visible polishing lines or "grain." When visible lines are present, always scrub in a motion parallel to the lines. When the grain cannot be seen, play it safe and use a soft cloth or plastic scouring pad.

3. Use alkaline, alkaline chlorinated or non-chloride containing cleaners.

While many traditional cleaners are loaded with chlorides, the industry is providing an ever-increasing choice of non-chloride cleaners. If you are not sure of chloride content in the cleaner used, contact your cleaner supplier. If your present cleaner contains chlorides, ask your supplier if they have an alternative. Avoid cleaners containing quaternary salts; it also can attack stainless steel and cause pitting and rusting.

4. Treat your water.

Though this is not always practical, softening hard water can do much to reduce deposits. There are certain filters that can be installed to remove distasteful and corrosive elements. To insure proper water treatment, call a treatment specialist.

5. Keep your food equipment clean.

Use alkaline, alkaline chlorinated or non-chloride cleaners at recommended strength. Clean frequently to avoid build-up of hard, stubborn stains. If you boil water in stainless steel equipment, remember the single most likely cause of damage is chlorides in the water. Heating cleaners that contain chlorides have a similar effect.

6. Rinse, rinse, rinse.

If chlorinated cleaners are used, rinse and wipe equipment and supplies dry immediately. The sooner you wipe off standing water, especially when it contains cleaning agents, the better. After wiping equipment down, allow it to air dry; oxygen helps maintain the stainless steel's passivity film.

7. Never use hydrochloric acid (muriatic acid) on stainless steel.

8. Regularly restore/passivate stainless steel.

Recommended cleaners for specific situations

Job	Cleaning Agent	Comments
Routine cleaning	Soap, ammonia, detergent, Medallion	Apply with cloth or sponge
Fingerprints & smears	Arcal 20, Lac-O-Nu Ecoshine	Provides barrier film
Stubborn stains & discoloration	Cameo, Talc, Zud, First Impression	Rub in direction of polish lines
Grease & fatty acids, blood, burnt-on-foods	Easy-off, De-Grease It Oven Aid	Excellent removal on all finishes
Grease & oil	Any good commercial detergent	Apply with sponge or cloth
Restoration/Passivation	Benefit, Super Sheen	

Review

1. Stainless steels rust when passivity (film-shield) breaks down as a result of scrapes, scratches, deposits and chlorides.
2. Stainless steel rust starts with pits and cracks.
3. Use the proper tools. Do not use steel pads, wire brushes or scrapers to clean stainless steel.
4. Use non-chlorinated cleaners at recommended concentrations. Use only chloride-free cleaners.
5. Soften your water. Use filters and softeners whenever possible.
6. Wipe off cleaning agent(s) and standing water as soon as possible. Prolonged contact causes eventual problems.

To learn more about chloride-stress corrosion and how to prevent it, contact the equipment manufacturer or cleaning materials supplier.

Developed by Packer Engineering, Naperville, Ill., an independent testing laboratory.

MAINTENANCE

INSPECTION AND MAINTENANCE CHECK LIST

Cleveland Range equipment requires little preventative maintenance. We do however provide the following chart as a guide line for inspection and maintenance to keep your unit functioning at 100%.

Item Inspection

MONTHLY INSPECTIONS

Switches	Inspect switches for damage and correct operation. Replace as required.
<u>Product Drain Valves</u>	
Butterfly Valve	Inspect parts for damage. Test valve for leakage. Replace as required.
Air Valve	Inspect parts for damage. Test valve for leakage. Check valve seals for air leakage. Inspect supply hose and fittings. Replace as required. Inspect air filter and replace if required.

SIX MONTH MAINTENANCE

Lubrication	Grease trunnion housings and gear/worm assembly as recommended in Lubrication Instructions. Grease bridge swivel assembly. Use "Never Seize" on tilt worm and gear.
Kettle Console Cover	Inspect gasket material for integrity. Replace if necessary. Insure all screws are in place and firmly holding down the cover. If not replace/tighten screws.
Hand wheel (hand tilt models only)	Check hand wheel for tightness. If loose tighten allen screw.
Tilting (tilting models only)	Check that kettle tilts smoothly. Grease as described in Lubrication Procedure.
On-Off Switch/Temperature Control	Check for damage. Replace if necessary.
Pressure Gauge	Check that the gauge shows a vacuum (needle is well into the Green zone) when cold and shows between 25-40 psi when unit is hot. If not follow Vacuum Leak Test Procedure.
Pressure Relief Valve	Check pressure relief valve as described in Pressure Relief Valve Testing Procedure .
Temperature Check	Following Calibrating Procedure check the inner kettle surface temperature with a digital surface thermometer. Adjust if required.
Gear/Worm Assembly	Inspect for play. Tighten Allen screws if required.

YEARLY MAINTENANCE

Lubrication	Drain hydraulic oil and remove filter. Replace oil and filter (see Hydraulic Oil Replacement Procedure).
Solenoid Valves	Inspect solenoid valves for proper operation. Clean or replace as required.

KETTLE SAFETY INSPECTION CHECKLIST

Regular inspection and maintenance of units is essential to obtain trouble free and safe operation of equipment. Inspections must include testing of the pressure relief valve and checks of the operating system to insure that it has not been altered.

No safety features designed into the equipment should ever be tampered with. Tampering with or bypassing controls is a very dangerous practice and unfortunately we have seen several cases of this. Following is a short list of the most common and the most dangerous alterations performed on kettles.

SAFETY VALVE:

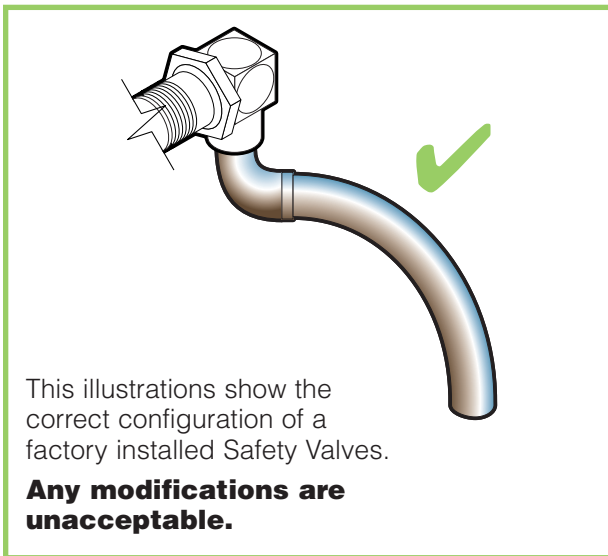

Incorrect Installations

- 1** Safety valve has plug threaded into the discharge opening preventing any steam from escaping.
- 2** Safety valve's tube diameter has been reduced.
- 3** Safety valve is sticking, frozen shut or plugged. To test PRESSURE RELIEF VALVE PERIODIC TESTING.
- 4** Safety valve is plumbed to a drain or water line creating back pressure and reducing flow.

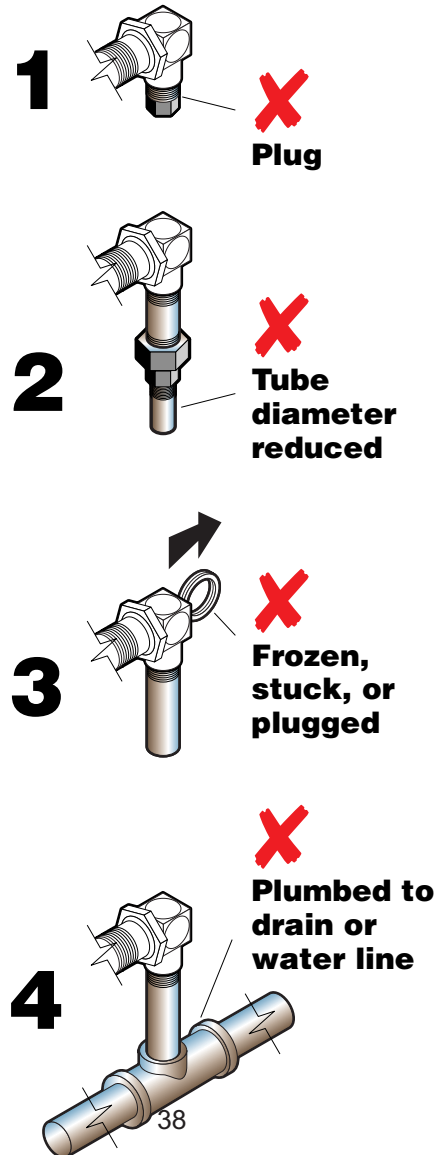

SAFETY THERMOSTAT:

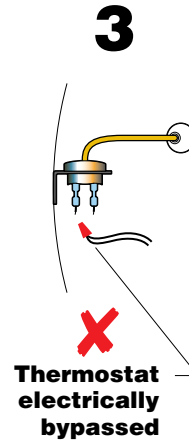
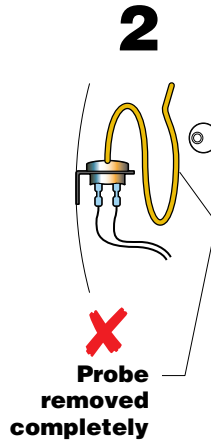
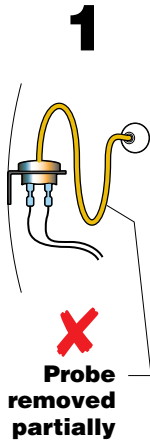
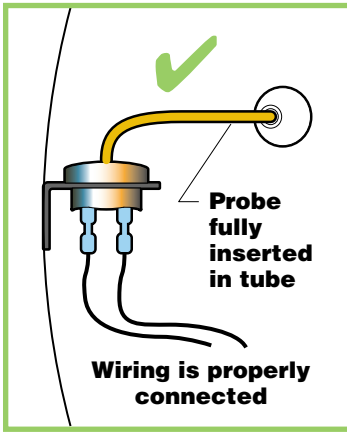

Incorrect Installations

1 Safety thermostat probe is not completely inserted into tubing.

2 Safety thermostat probe is removed from tubing.

3 Safety thermostat electrical connection is bypassed.

Low Water Level Probe:

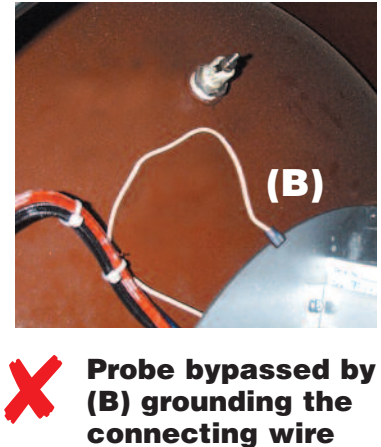
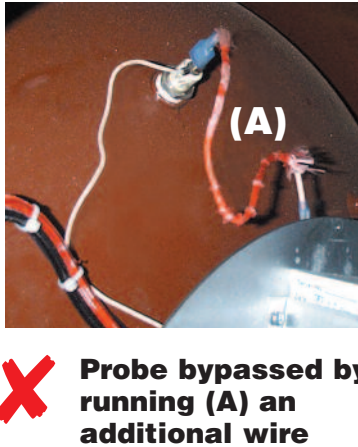
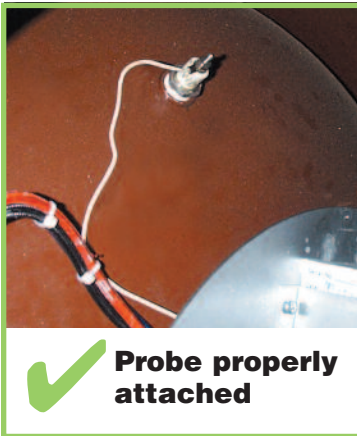

Operating Thermostat:

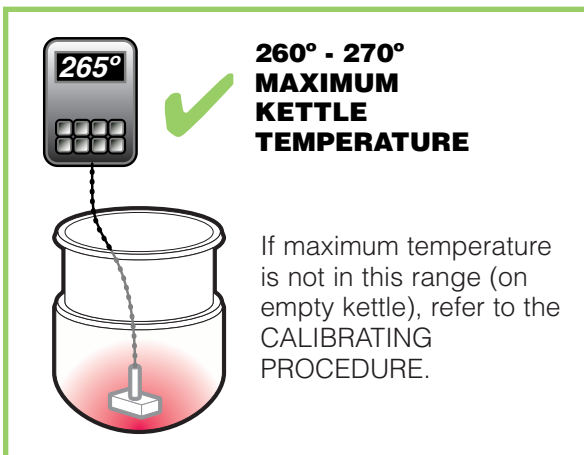

Air Switch:

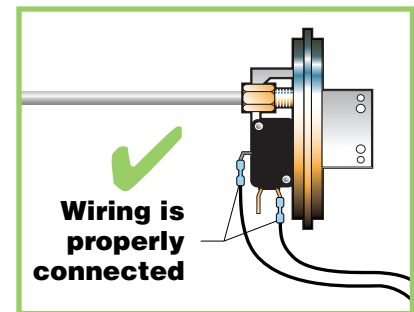

Incorrect Installation

