

36" x 36" and 30" x 48" Bar Height Tables Mid-Century Table Base



LANCASTER
TABLE & SEATING

ASSEMBLY INSTRUCTIONS

PARTS LIST:

A Side Legs 2/PCS

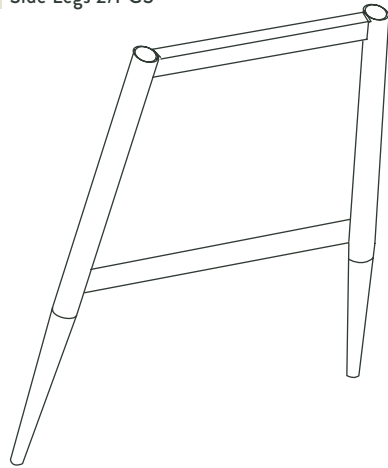

B Cross Bars 2/PCS



C Connector Bar 1/PC



D Corner Supports 4/PCS



E Bolts 28/PCS



F Tabletop Screws 4/PCS



G Allen Key 1/PC



NOTES:

1. Inspect all pieces for damage before assembly. Do not assemble if any pieces are broken or damaged. Ensure you have all required pieces before assembly.
2. Check tabletop screw length to verify compatibility with chosen tabletop.
3. Phillips head screwdriver (not included) needed to attach tabletop (power drill is optional).

STEP 1

Lay 1 side leg (A) on a smooth, clean surface. Take 1 cross bar (B) and align with holes on the top bar of side legs. Using the allen wrench (G), secure with 4 bolts (E). Do not fully tighten until step 5. Repeat for the second cross bar, do not fully tighten.

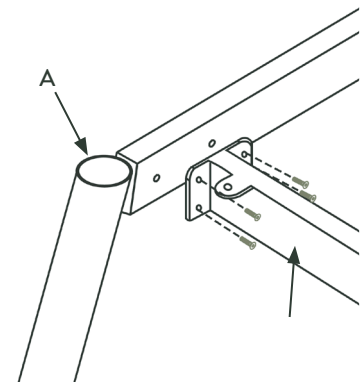
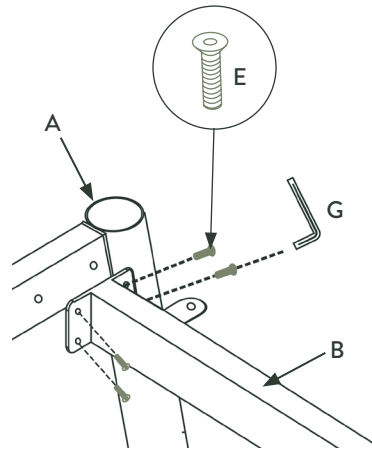
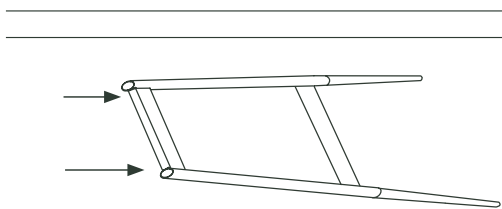

STEP 2

Stand side legs up and align side legs (A) with the other end of the cross bars (B). Using the allen wrench (G), secure both cross bars to both side legs with 4 bolts (E) per connection as shown below. Do not fully tighten until step 5.

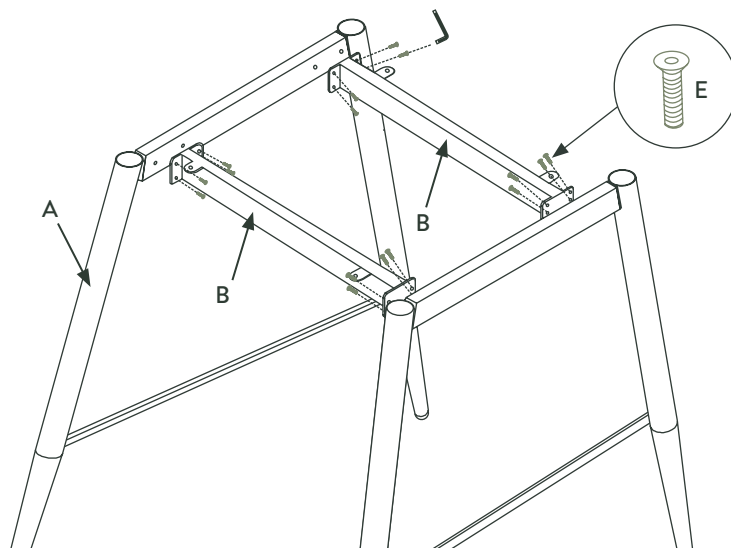

36" x 36" and 30" x 48" Bar Height Tables Mid-Century Table Base



LANCASTER™
TABLE & SEATING

ASSEMBLY INSTRUCTIONS

STEP 3

Turn base upside down on a smooth, clean surface. Using the allen wrench (G) and 2 bolts (E), attach corner support (D) from cross bar to side leg. Repeat for other 3 legs. Do not fully tighten until step 5.

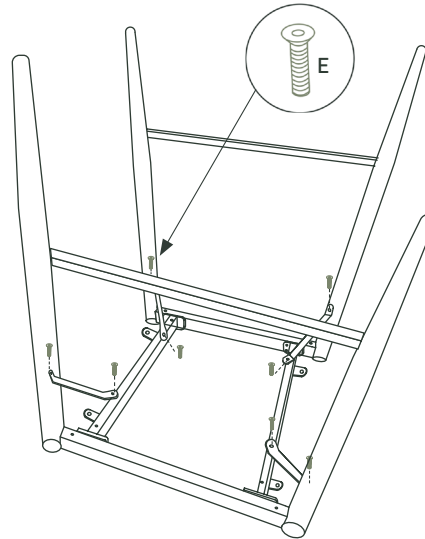
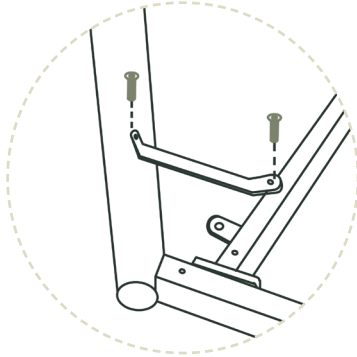

STEP 4

Attach connector bar to bottom horizontal bar of the side leg using the allen wrench (G) and 2 bolts (E) per side. Do not fully tighten until step 5.

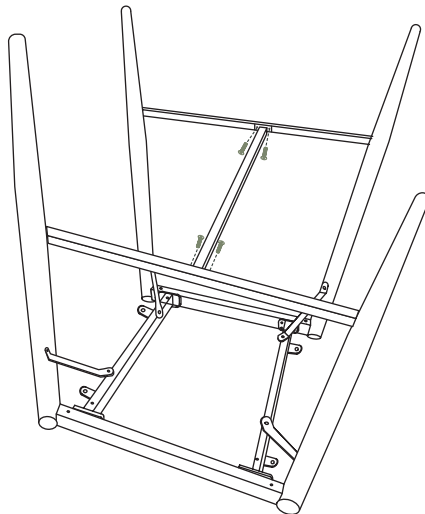

STEP 5

Flip base right side up. Make sure base is level on flat ground, then tighten all bolts.

STEP 6

Be sure to verify screw length with chosen tabletop before installing! To attach to tabletop, turn tabletop upside down on a smooth, clean surface. Turn table base upside down on top of tabletop. Center base, and secure with 4 tabletop screws (F).

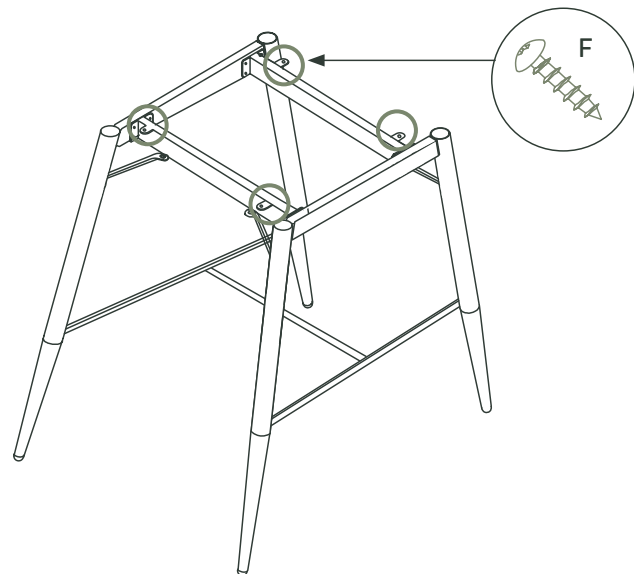

CLEANING & MAINTENANCE

- Periodically tighten bolts as needed.
- Wipe down table base with a damp cloth.
- Follow specific instruction for tabletop cleaning and maintenance.