

30" x 30" Standard Height Tables Mid-Century Table Base



ASSEMBLY INSTRUCTIONS

PARTS LIST:

A Side Legs 2/PCS

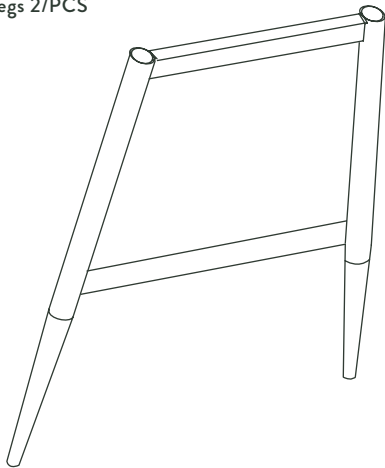

B Cross Bars 2/PCS

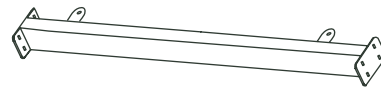

C Bolts 16/PCS



D Tabletop Screws 4/PCS



E Allen Key 1/PC



NOTES:

1. Inspect all pieces for damage before assembly. Do not assemble if any pieces are broken or damaged. Ensure you have all required pieces before assembly.
2. Check tabletop screw length to verify compatibility with chosen tabletop.
3. Phillips head screwdriver (not included) needed to attach tabletop (power drill is optional).

STEP 1

Lay 1 side leg (A) on a smooth, clean surface. Take 1 cross bar (B) and align with holes on the top bar of side legs. Using the allen wrench (E), secure with 4 bolts (C). Do not fully tighten until step 3. Repeat for the second cross bar, do not fully tighten.

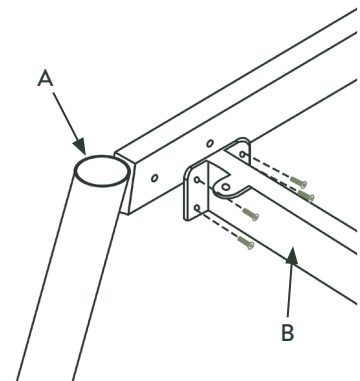
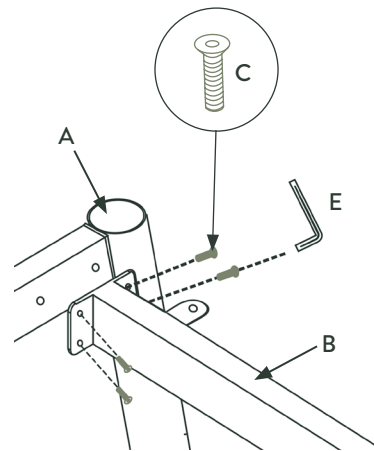
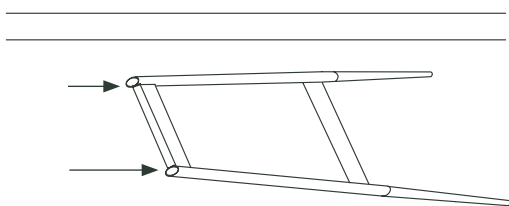

STEP 2

Stand side legs up and align side legs (A) with the other end of the cross bars (B). Using the allen wrench (E), secure both cross bars to both side legs with 4 bolts (C) per connection as shown below. Do not fully tighten until step 3.

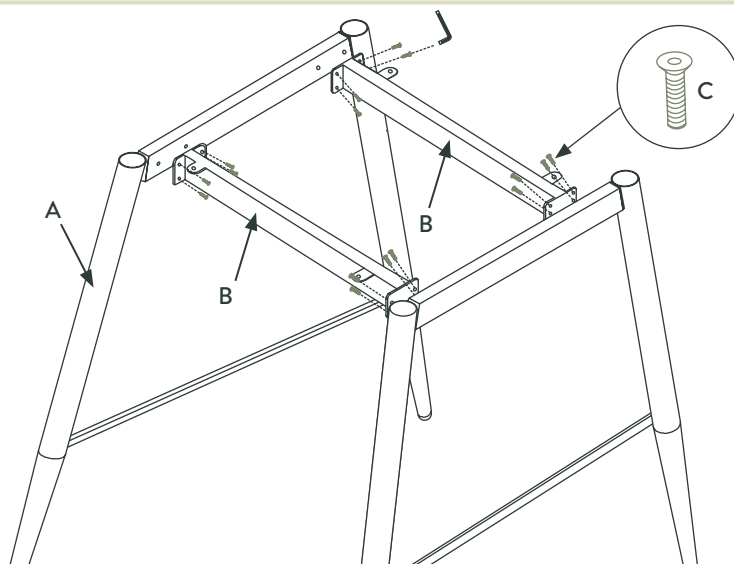

30" x 30" Standard Height Tables Mid-Century Table Base

ASSEMBLY INSTRUCTIONS



STEP 3

Make sure base is level on flat ground, then tighten all bolts.

STEP 4

Be sure to verify screw length with chosen tabletop before installing!
To attach to tabletop, turn tabletop upside down on a smooth, clean surface. Turn table base upside down on top of tabletop. Center base, and secure with 4 tabletop screws (D).

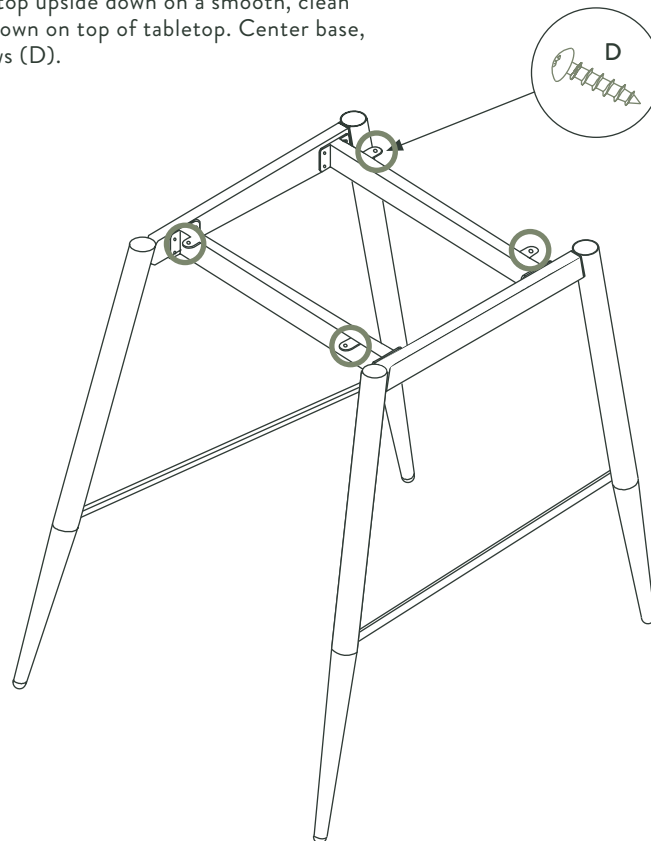

CLEANING & MAINTENANCE

- Periodically tighten bolts as needed.
- Wipe down table base with a damp cloth.
- Follow specific instructions for tabletop cleaning and maintenance.