



Undercounter Ice Machine User's Manual

12/2021

194UC120A, 194UC160FA, 194UC160HA, 194UC210FA, 194UC210HA,
194UC280FA, 194UC280HA

*Please read the manual thoroughly prior to equipment set-up,
operation and maintenance.*

Warning and Safety

DANGER – RISK OF FIRE OR EXPLOSION. FLAMMABLE REFRIGERANT USED. TO BE REPAIRED ONLY BY TRAINED SERVICE PERSONNEL. DO NOT PUNCTURE REFRIGERANT TUBING.

PELIGRO - RIESGO DE INCENDIO O EXPLOSION. REFRIGERANTE INFLAMABLE UTILIZADO. PARA SER REPARADO SOLAMENTE POR PERSONAL DE SERVICIO CALIFICADO. NO PINCHAR LA TUBERÍA REFRIGERANTE.

DANGER – RISQUE DE FEU OU D'EXPLOSION. LE FRIGORIGÈNE EST INFLAMMABLE. CONFIER LES RÉPARATIONS À UN TECHNICIEN SPÉCIALISÉ. NE PAS PERFORER LA TUBULURE CONTENANT LE FRIGORIGÈNE.

CAUTION – RISK OF FIRE OR EXPLOSION. FLAMMABLE REFRIGERANT USED. CONSULT REPAIR MANUAL/OWNER'S GUIDE BEFORE ATTEMPTING TO SERVICE THIS PRODUCT. ALL SAFETY PRECAUTIONS MUST BE FOLLOWED.

ATENCIÓN - RIESGO DE INCENDIO O EXPLOSIÓN. REFRIGERANTE INFLAMABLE UTILIZADO. CONSULTE EL MANUAL DE REPARACIÓN / GUÍA DEL PROPIETARIO ANTES DE INTENTAR DAR SERVICIO A ESTE PRODUCTO. DEBEN CUMPLIR CON TODAS LAS PRECAUCIONES DE SEGURIDAD.

ATTENTION – RISQUE DE FEU OU D'EXPLOSION. LE FRIGORIGÈNE EST INFLAMMABLE. CONSULTER LE MANUEL DU PROPRIÉTAIRE/GUIDE DE RÉPARATION AVANT DE TENTER UNE RÉPARATION. TOUTES LE MESURES DE SÉCURITÉ DOIVENT ÊTRE RESPECTÉES.

CAUTION – RISK OF FIRE OR EXPLOSION DUE TO PUNCTURE OF REFRIGERANT TUBING; FOLLOW HANDLING INSTRUCTIONS CAREFULLY. FLAMMABLE REFRIGERANT USED.

ATENCIÓN - RIESGO DE INCENDIO O EXPLOSIÓN DEBIDO A LA PERFORACION DE LA TUBERÍA REFRIGERANTE; SIGA LAS INSTRUCCIONES DE MANIPULACIÓN CON CUIDADO. REFRIGERANTE INFLAMABLE UTILIZADO.

ATTENTION – RISQUE DE FEU OU D'EXPLOSION SI LA TUBULURE CONTENANT LE FRIGORIGÈNE EST PERFORÉE; SUIVRE LES INSTRUCTIONS DE MANUTENTION AVEC SOIN. LE FRIGORIGÈNE EST INFLAMMABLE.

CAUTION – RISK OF FIRE OR EXPLOSION DUE TO FLAMMABLE REFRIGERANT USED. FOLLOW HANDLING INSTRUCTIONS CAREFULLY IN COMPLIANCE WITH LOCAL GOVERNMENT REGULATIONS.

ATENCIÓN – RIESGO DE INCENDIO O EXPLOSIÓN DEBIDO A REFRIGERANTE INFLAMABLE UTILIZADO. SIGA LAS INSTRUCCIONES DE MANIPULACIÓN CON CUIDADO CONFORME A LAS REGLAS DE LA MUNICIPALIDAD.

ATTENTION – RISQUE DE FEU OU D'EXPLOSION SI LE FRIGORIGÈNE EST INFLAMMABLE. SUIVRE LES INSTRUCTIONS DE MANUTENTION AVEC SOIN CONFORMÉMENT AUX RÈGLEMENTATION GOUVERNEMENTALE LOCAUX.

This product cannot be used in outdoor environments. Not intended for use by children, persons with reduced physical, sensory or mental capabilities or lack of experience and knowledge.

- The installation, repair or maintenance of this ice machine must be carried out by professional and qualified personnel. Electric shock, fire, personal injury may result from incorrect operation.
- After the ice machine is delivered, please keep the machine upright for at least 24 hours to have the refrigerant be fully precipitated before startup. Otherwise the compressor may be damaged.
- When handling, keep the cabinet upright with the inclination not exceeding 45 degrees. Do not invert the machine or lay it horizontally.
- This ice machine should not be placed in wet or easily splashed areas.
- The grounding of this ice machine cannot be connected to a gas pipe, water pipe, telephone line or lightning rods, etc.
- There are rotating components in this ice machine. Do not insert slim objects into ventilation or exhaust ports, or serious mechanical damage and injury may occur.
- Do not store volatile or flammable substances in this ice machine or it may result in explosion or fire.
- Do not store any sundries or freeze any food in the storage bin. Keep the ice scoop clean.
- The ice machine must be placed on a floor sufficient enough to support its weight. Insufficient base may cause the equipment to fall over and cause injury.
- There should be sufficient ventilation space around the ice machine. See page 5 for clearance requirements.
- Only the power supply specified on the machine nameplate can be used with this ice machine.
- This ice machine cannot be connected to hot water.
- Outlet for this ice maker must be reliably grounded with leakage protection.
- The ice machine must be disconnected from power before manual cleaning, repairing and maintenance.
- Before cleaning, repairing and maintenance, the remaining ice in the ice bin should be removed from the ice machine to avoid contamination to ice.
- Do not splash water directly onto the surface of the ice machine during the cleaning process; otherwise it may cause short circuit, leakage or other faults.
- Flammable foaming agent is used during the foaming process. The ice maker should be disposed of and recycled by qualified personnel and institutions.
- The ice machine should be properly managed to ensure that children will not play with the machine.
- When the ice machine malfunctions, turn off the power and contact professional personnel for repairing

User Manual



The ice machine is fully automatic. With proper installation and connection to potable water and power source, the ice making will start properly. When the ice cubes fill up the storage bin, the machine will automatically stop. The ice machine is generally used in the following and similar occasions:

- Indoor, ambient controlled environments only.
- The kitchen area of a store, office or other workplace;
- Hotel and restaurant;
- Catering and similar non-retail occasions;
- This ice machine is not intended for residential use



C Pure creates specialty water filters to be used with common restaurant equipment, ensuring that the water utilized by the equipment is both clean and clear. These filters are easily installed into water lines, and their cartridges can be quickly swapped out for fast, easy and efficient replacements. The water filters below are approved for use with Avantco Ice Machines. Failure to use and maintain an appropriate water filter will void warranty coverage on your Avantco Ice Machine. For installation instructions, refer to the C Pure water filtration manual or contact a C Pure water filtration dealer.

Item Number	Ice Shape	Ice Production Per 24 Hrs.	Recommended Water Filtration System	Replacement Cartridge
194UC120A	Full Dice	120 lbs.	790OCLOKITM	790OCLOCARTM
194UC160FA	Full Dice	160 lbs.	790OCLOKITM	790OCLOCARTM
194UC160HA	Half Dice	160 lbs.	790OCLOKITM	790OCLOCARTM
194UC210FA	Full Dice	210 lbs.	790OCLOKITM	790OCLOCARTM
194UC210HA	Half Dice	210 lbs.	790OCLOKITM	790OCLOCARTM
194UC280FA	Full Dice	280 lbs.	790OCLOKITM	790OCLOCARTM
194UC280HA	Half Dice	280 lbs.	790OCLOKITM	790OCLOCARTM

Installation

The ice machine should be installed in a proper location meeting the following conditions:

- Indoors, ambient temperature: 40-90°F;
- Power supply: the rated voltage indicated on the machine nameplate $\pm 6\%$;
- Water source: potable water, with water pressure from 18.75 psi to 80 psi; water temperature: 40-90°F;
- The ice machine should be kept away from heat sources, and should be strictly forbidden to use at an extremely high temperature or low temperature environment, and should avoid direct sunlight.
- There should be sufficient ventilation space around the ice machine and good ventilation; the distance from the ice maker to the wall should be no less than 12" for the front, 6" for the sides, and 8" for the rear.
- The ice machine must be placed on a floor sufficient to support its weight;
- The socket for the ice maker must be reliably grounded and with leakage protection;
- Proper floor drainage must be provided near the installation location of the ice machine.

Schematic Diagram

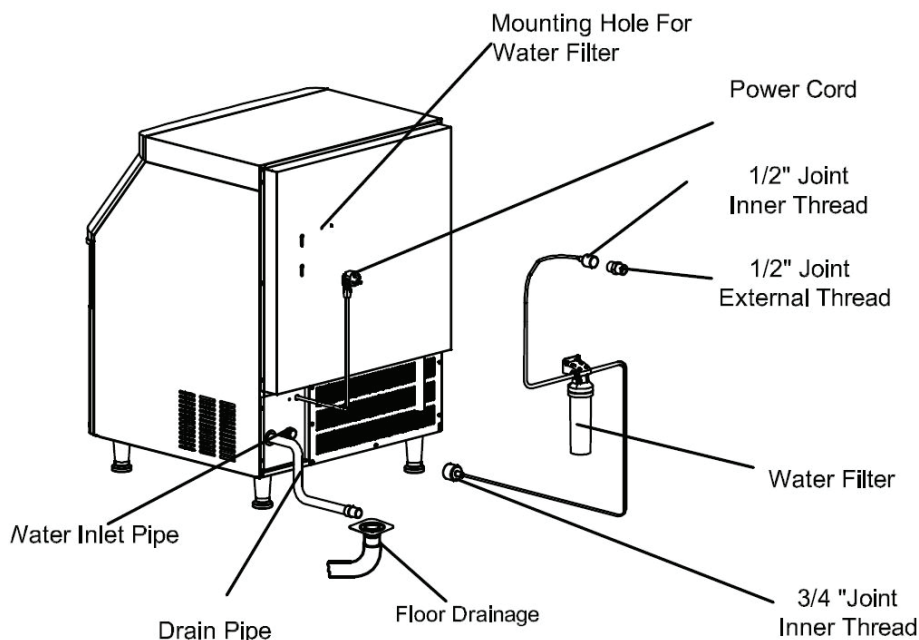

Installation Steps

1. Check to see if the ice machine is in good condition and the accessories are all present; check the machine model and the machine nameplate.
2. Clean the ice storage bin and the food area inside with a sponge soaked in warm water and soap. Then wash and dry it with potable water.
3. Place the ice machine in the operation area; ensure that the machine is placed on a leveled floor. So as to ensure the water flows evenly into the evaporator.
4. The compressor chamber is located below the front of the ice bin. The compressor and condenser are installed in it. It requires good ventilation. Therefore, the ice maker must have ventilation space of more than 8" in the rear, 6" on the sides, and 12" in the front.
5. The bottom of the ice machine is equipped with adjustable legs for level adjustment and clearance for floor cleaning.
6. Connect the ice machine's inlet water filter and water line referring to the installation instructions of your water filter brand. If the installation site is already equipped with a drinking water system, the water filter may not be installed
7. Connect the machine to the water supply using the 3/4" inlet fitting supplied with the machine. It is recommended to install a water ball valve (not supplied with this machine) on the water supply line.
8. Connect the drain line to the drain connector. In order to achieve a proper draining, it is recommended that the drain pipe should have a difference in level of more than 1" per 3'; and confirm that the drain line is not blocked. It is recommended that the drain line be connected to an open drainage port.
9. Any joint in the drain line must not be higher than the machine drainage port; any joint in the drain line cannot be higher than the previous joint.
10. Confirm the power requirements stated in the machine's nameplate; ensure that the power supply meets the requirements.
11. A circuit breaker or switch with leakage protector and reliable grounding is required.
12. Turn off the switch on the power line and connect the machine to the power source.

NOTE: the filter flow direction should be correctly installed as per the direction marker on the filter head cover or the filter body. The filter cartridge should be replaced every 3 to 6 months.

Startup and Operation

1. Before you start up the machine, please check and confirm:
 - That the packaging tape inside the ice machine has been removed;
 - The accessories or items in the ice bin have been taken out;
 - The ice machine has been adjusted to a leveled state;
 - The water line has been connected and the water valve is open;
 - The plug has been connected to the power supply and the power switch is off.
 - The ambient temperature, water temperature, and pressure of the water supply meet the above requirements.
2. Start up: turn on the power switch. After power-on, the machine begins to make ice automatically.
3. For normal operation, please confirm:
 - There is water in the water trough and no overflow occurs;
 - The pump is working properly and water is flowing evenly in the evaporator;
 - The compressor is running normally, the temperature of the evaporator and the ice making water is gradually decreasing;
 - For air cooled machines, make sure the fan is running normally, and there is stable air flow in the inlet and outlet of the ice machine;
 - The ice machine has no abnormal noise;
 - The ice machine has no abnormal vibration;
 - It takes about 10 to 20 minutes to make one batch of ice, depending on the ambient temperature and the temperature of the water. The higher the temperature is, the longer the ice making will take;
 - Ice cubes can be properly harvested from the machine.

Operation Instructions

- **Startup:** after proper installation, connect the water source and turn on the power supply, the machine will start working. Please confirm that the machine is operating normally when you turn it on for the first time.
- **Self-check:** with power on for the first time, the ice maker will do a self-check and pump out any remaining water.
- **Preparing:** after the ice machine is energized, the inlet valve opens and the inlet water will flow in until it reaches the set level; then the ice maker will defrost one time.
- **Ice making:** after pre-cooling for 30 seconds, the water pump starts, the water flows through the evaporator smoothly and evenly, the ice cubes are gradually formed in the ice cube tray.
- **Ice Harvest (Drop):** after the ice making process, the water pump is turned off, the defrosting valve is turned on, and after the hot gas enters into the evaporator for about 1-2 minutes, the ice cubes slide from the evaporator into the storage bin.

Warning: Do not put your hand into the ice storage bin during the ice-falling process to prevent the ice from hitting your hand!

- **Shutdown:** The ice maker will stop working when you push the “on/off” button on the control panel during the running process.
- **Bin full stop:** Once the ice storage bin is filled to a certain height, the ice making process will stop after 40 seconds. There is a sensor at the top of the bin which will trigger this stop in production. In order to maximize the bin space make sure to spread around the ice that piles up in front of the sensor
- **Repeat ice-making:** When the ice cubes triggering this sensor are moved or taken away, the ice maker will go back to the ice making process within seconds

Control Panel

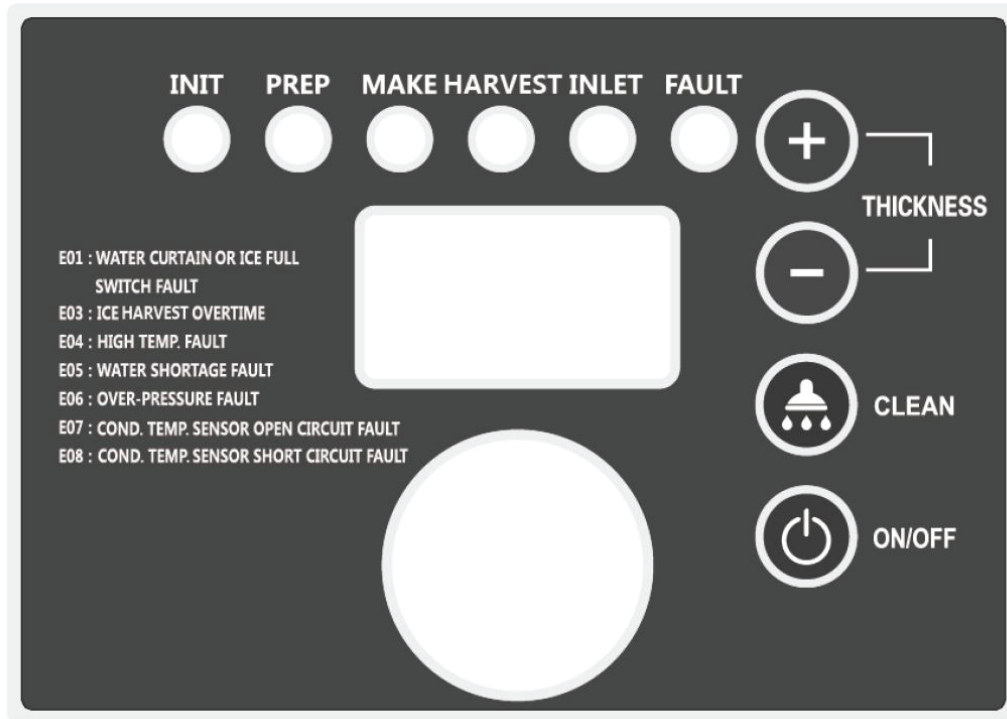

1. LED Display:

- Self-check: Display “ini” code.
- Preparing: Counts (in seconds) forwards.
- Ice making: Counts (in seconds) forwards prior to the water reaching 32 degrees F. Counts seconds backwards to 0 seconds afterwards.
- Ice Harvest: Counts (in seconds) forwards.
- Clean: Display “CLE” during cleaning and descaling; Display “STL” during sanitizing; Display “RIN” during rinsing.

2. LED Lamps: Turns lights on/off

3. Ice cube thickness adjustment: During the ice making process, if you are not satisfied with the ice thickness, press the Ice cube “-” button for 3 seconds, then click the button “+” or “-” on the panel to adjust the thickness of ice cube.

- Note: By clicking the “+” or “-” button one time, the ice making time is extended or shortened by 1.5 minutes.

4. Cleaning: During the normal operation, hold the cleaning button for 3 seconds to enter the cleaning process. During the entire cleaning process, cleaning agents and disinfectants need to be put into the water trough. When the cleaning process is finished, the ice maker will go to the ice making process.

Note: All cleaning and sanitizing chemicals used must be nickel safe

5. ON/OFF: Press this button to switch the machine OFF/ON.

6. Please open and close the storage bin door gently. Do not slam the door. Keep door closed when not scooping ice.

7. If the ice maker is not in use for a long time, it should be energized and run for 2 to 4 hours every 2 months.

Other Special Protection - Shutdown

- If the ice machine has not detected ice harvest in three cycles, it will shut down for safety protection. The ice maker needs to be checked.
- If the ice machine detects that the ambient temperature is too high it will stop for safety protection.
- The fault code and its comments are displayed as follows:

Code	Comments	Machine Action
E01	Sliding board failure	Protective shutdown
E02	Ice making overtime	Protective shutdown
E03	Overtime of ice making	Protective shutdown
E04	High temperature	Protective shutdown
E05	Water shortage	Protective shutdown
E06	High pressure	Protective shutdown
E07	Condensation sensor open circuit	Does not shutdown, Error LED light on every 5 seconds
E08	Condensation sensor short circuit	Does not shutdown, Error LED light on every 5 seconds
E09	Evaporator sensor open circuit	Does not shutdown
E10	Evaporator sensor short circuit fault	Does not shutdown
E11	Refrigeration system failure	Protective shutdown
E12	Water level control fault	Protective shutdown



Noble Chemical offers a full line of products to clean and sanitize your commercial ice machine. These chemicals are approved for use with Avantco Ice Machines. Failure to regularly clean and sanitize your Avantco Ice Machine will void warranty coverage. For information and instructions, contact a Noble Chemical dealer. The ice machine needs to be cleaned every other month, or once a month for high yeast environments.

Cleaners

Item Number	Size	Type
147ARCTIC	16 oz.	Concentrate
147ARCTICRPT	16 oz.	Ready to use
147ARCTICR1G	1 Gallon	Ready to use

Sanitizers

Item Number	Size	Type
147QKSANICE	12 Pack/16 oz. Bottles	Concentrate
999QKSANICE	16 oz.	Concentrate

Maintenance

NOTE: Maintenance must be done by a qualified technician.

WARNING: Before maintenance or manual cleaning, be sure to shut off the water source and power supply.

Exterior Cleaning

- Frequently clean the environment around the ice machine to keep it clean.
Do not block the vents.
- The outer enclosure should be cleaned with a mild detergent and then wiped clean.
If necessary, use commercial stainless steel cleaners and polishes.

NOTE: Stainless steel may rust without proper maintenance.

Inlet Water Filter

- The water filter should be inspected regularly. It is recommended to replace the filter cartridge every 3 to 6 months.

Interior Cleaning

- The inside of the ice storage bin can be washed with water and cleaner solution.
Rinse thoroughly with water. Repeat this process with a water and sanitizer solution.
- Note: Check and confirm the water pressure is lower than the maximum allowed pressure.
Do not flush the part above the water pump or the evaporator directly for water protection.

Condenser

- For the air-cooled ice maker, the condenser should be cleaned every three weeks. Use a soft brush or a vacuum cleaner with a brush to brush it up and down along the fin direction, to avoid damage to the fins and further affecting the cooling effect.
- The condenser filter should be cleaned every 2 weeks.

NOTE: Be careful when cleaning the condenser as the edges of the fins are sharp.

Water Line

- In order to ensure food safety, the water line of the ice machine should be cleaned regularly.

Winterizing

- Turn off the water and power supply, drain the residual water from the water trough inlet pipe and drain pipe.

NOTE: The maintenance of the ice machine is not covered by the manufacturer's warranty!

Clean Function

NOTE: Please empty the bin of ice in advance.

NOTE: Please clean and sanitize the bin and do a complete rinsing.

NOTE: Please clean and sanitize the ice sliding board, water distribution line, water supply line, water pump, then do a complete rinsing.

- Turn on the ice maker; push “clean” button for 3 seconds, the ice maker will begin the cleaning process. Put in proper amount of cleaning solution manually into the water trough followed by the clean and sanitizing process instruction.
- Push “clean” button. The ice maker will do auto clean for about 15 minutes. Please spray clean the evaporator in the meantime to ensure a complete clean. When finished, the led display flashes “Clean” slowly again.
- Put in the proper amount of sanitizing solution manually into the water trough followed by the clean and sanitizing process instruction. Push the “clean” button again, the ice maker will do auto sanitizing for about 15 minutes. Please spray the evaporator with the sanitizing solution in the meantime to ensure complete sanitizing. When finished, the ice maker will go into the rinsing process, this process will take about 5 minutes, and do 5 rinsing cycles. Refer to your cleaner and sanitizer for proper mixing & coding instructions.
- The ice maker will go back to making ice as soon as the cleaning process ends.
- Please throw away the next 5 batches of ice in case of residual cleaner.

Manual Cleaning & Sanitizing

Cleaning Instructions



Note: Cut off the power

1. Remove all ice from the ice bin to avoid contamination.

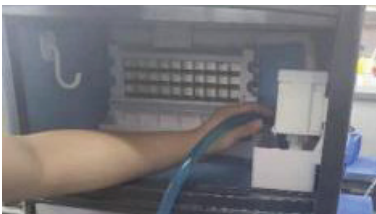

2. Empty the water from the tank.

3. Remove the water curtain.



User Manual

4. Remove the pump and pull out the upper pipe of the pump circulation.



5. Remove screws which are securing the spray pipe. Remove the spray pipe and the upper pipe.

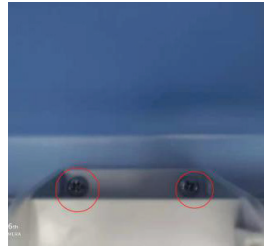

6. Disassemble fixed screws which are in the spray pipe. Dismantle the spray pipe.



7. Mix a solution of cleaner and water according to your ice machine cleaner instructions. Ensure the cleaning agent dissolves completely. Soak the water pipe, inlet and outer spray pipe, head, spray pipe fixing seat and screws, etc. in the cleaning solution for 5 minutes (or 15 minutes for heavily scaled components). Rinse all components thoroughly with clean water.



8. After soaking, scrub the spray pipe, water curtain and pump base bracket with cleaning solution, and rinse thoroughly with clean water.

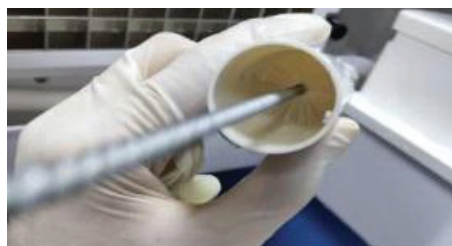
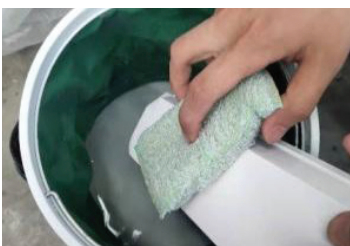

9. Spray the cleaning solution into the evaporator and wipe clean. Repeatedly wipe the water tank, ice plate and its plastic parts, side plates, ice buckets and other sanitary areas with cleaning solution. Rinse all areas thoroughly with clean water.



Sanitizing Instructions

1. Mix a solution of sanitizer and water according to your ice machine sanitizer instructions. Ensure the sanitizer dissolves completely. Soak the water pipe, inner and outer spray pipe, head spray pipe fixing seat and screws, etc. in the solution for 5 minutes. If using a no-rinse sanitizer, there is no need to rinse.

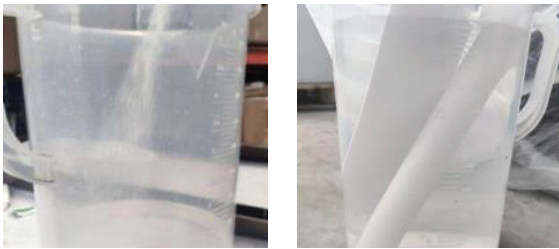

2. Spray the spray pipe, water curtain and pump base bracket with the sanitizer solution. If using a no-rinse sanitizer, there is no need to rinse.



3. Spray the sanitizer solution into the ice evaporator with a spray bottle. Spray the water tank, ice plate and its plastic parts, side plates, ice bin and other sanitary areas with sanitizer solution. If using a no-rinse sanitizer, there is no need to rinse.



4. Allow the dismantled spray pipe, water pump, water pipe, and water curtain to dry. Then install them back to their original position.

Service Call

If the ice machine works abnormally, please confirm below before making a service call:

1. Check the water supply

- Whether there is water in the water trough;
- Whether the water pressure for the is 18.75 psi to 80 psi; the water temperature is 40-90°F;
- Whether the water valve is open;
- Whether there is no water leakage;

2. Check the power

- Whether the indicator on the display panel is ON;
- Whether the panel display does not display the OFF standby state;
- If the LED on the display panel is not ON, check whether the plug and socket are normal, and whether the power supply switch is ON.

3. Check nameplate and serial number

- Check the nameplate located on the side or back of the ice machine and record the model and series number of the ice machine.

Note: If the machine fails due to the user's faults, such as failure to use and maintain a water filter, no supply of water, electricity or environmental factors, rather than the fault of the ice maker, the door-to-door service will be charged.

Troubleshooting

Fault	Potential Cause	Troubleshooting
Not working	Power switch not turned on	Turn on the power switch
Indicator is OFF	Plug is loose	Check plug and socket
Shutdown every 3 minutes after startup;	The ambient temperature is too high	Normal working temperature range of 41-95°F
The display shows E04 high temperature	Condenser is dirty and blocked High pressure switch wires fallen off	Clean the condenser
The display shows E06 high pressure protection	Fan does not start	Check and correct high pressure switch wires Check and correct the fan
Ice defrost abnormal	Ambient temperature too low	Normal working temperature range of 41-95°F
	Defrost valve does not start normally	Check and correct the defrosting valve
	Ice thickness too thin or too thick	Check and correct ice thickness setting

User Manual

Poor transparency of ice cubes; ice cubes too thin or incomplete	Ice thickness is too thin	Check and correct ice thickness setting
	Water pressure is too low	Check that the water supply pressure is 1.3 bar to 5.5 bar
	Water temperature is too high	Normal working temperature range of 41-95°F
	Inlet water valve does not work	Check and correct the inlet water valve
	Inlet water valve is dirty and blocked	Check whether water leaks and correct
	Water leaking	Check and correct the inlet water filter and water connection
	Inlet water filter has not been replaced for a long time	
Too slow in ice making	The condenser or air filter is dirty	Clean the condenser and filter screen
	High ambient temperature	Normal working temperature range of 41-95°F
	Poor ventilation	Check the environment around the ice machine
	Water temperature is too high	Check the water supply temperature of 41-95°F
Too much noise	The ice machine is not placed in a leveled foundation or the ice maker is not leveled	Level the ice machine