



## Countertop Tortilla/Portion Steamer

**Models:** QuickShot QS-1800

05/2020

***Please read and keep these instructions. Indoor use only.***

## Index

Specifications .....	3
Important Safety Information .....	4
Identification of Key Parts .....	5
Installation of Your Steamer .....	6
Before Using Your Steamer .....	6
Using Your Steamer .....	6
Typical Operation Sequence .....	7
Cleaning and Maintaining Your Steamer .....	7
Daily Maintenance .....	7
Monthly Maintenance .....	7
Water Tank Filter Maintenance .....	8
Parts List .....	9
Limited Warranty .....	10

BEFORE USE, PLEASE READ AND FOLLOW ALL SAFETY RULES AND OPERATING INSTRUCTIONS.

## Specifications

Model #	Power Supply	Dimensions	Size	Plug
177QS1800	120V 1800W	16 1/2"W x 15"D x 7 7/8"H	Half 120V	NEMA 5-15P

## Explanation of Graphical Symbols

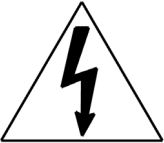

### WARNING

RISK OF FIRE OR ELECTRIC SHOCK  
DO NOT OPEN



---

WARNING, TO REDUCE THE RISK OF FIRE OR ELECTRIC SHOCK,  
DO NOT REMOVE COVER (OR BACK)  
NO USER-SERVICEABLE PARTS INSIDE  
REPAIR SHOULD BE DONE BY AUTHORIZED SERVICE  
PERSONNEL ONLY.



The lightning flash with arrowhead symbol, within an equilateral triangle, is intended to alert the user. It provides a warning for the presence of uninsulated "dangerous voltage" within the product's enclosure. This voltage may be of sufficient magnitude to constitute a risk of fire or electric shock to persons.



The exclamation point, within an equilateral triangle, is intended to alert the user of important operating and maintenance instructions accompanying the appliance.

## Important Safety Information

**When using electrical appliances, basic safety precautions should always be followed, including the following:**

1. Read all instructions carefully and completely.
2. Electrical appliances are for commercial use only.
3. Do not touch hot surfaces.
4. Plug into a 3-hole grounded electrical connection only.
5. Protect against electrical shock by keeping all cords, plugs, and other electrical components away from water or other liquids.
6. Unplug this unit when not in use and before cleaning.
7. Allow the unit to cool before putting on or taking off parts.
8. Do not operate this or any appliance with a damaged electrical cord or plug.
9. Do not operate this or any appliance after it has malfunctioned or been damaged in any way.
10. Do not use outdoors.
11. Do not place on or near a hot gas or electric burner.
12. Attach plug to appliance first, then plug electrical cord into the wall outlet.
13. Disconnect the unit by turning the temperature and timer control to "OFF", then removing the electrical plug from the wall outlet.
14. Do not use appliance for any application other than intended use.
15. Do not insert metal utensils or oversized foods into this unit as they may cause a fire and heighten the risk of electrical shock.
16. Do not store any item on top of this unit when in operation.
17. Do not allow this steamer to touch or be covered by flammable material, such as curtains, draperies, walls, etc., when in operation.
18. Do not clean with metal scouring pads as pieces can break off and touch electrical components, heightening the risk of electrical shock.
19. Never place materials such as paper, cardboard, plastic, etc. in this steamer.
20. Incorrect installation, adjustments, modifications, and/or improper maintenance may result in injury or property damage. All repairs should be completed by authorized professionals only.
21. Turn the appliance off by turning the temperature and timer control to the "OFF" position.
22. Note that the use of accessories not recommended by the manufacturer may result in injury.
23. Children should be supervised to ensure that they do not play with the steamer.
24. Keep animals away from the unit.
25. This appliance is not intended for use by persons (including children) with reduced physical sensory or mental

capabilities, or lack of experience and knowledge, unless they have been given supervision or instruction concerning use of the appliance by a person responsible for their safety.

- 26. When using the appliance in shops, snack bars, hotels etc., check the voltage and outlet to make sure the appliance is correctly connected to power.
- 27. Place unit on a flat, dry surface that is well ventilated. The appliances must be supervised during operation; DO NOT leave appliance without powering off.

**NOTE: Save these instructions for future reference.**

## Identification of Key Parts

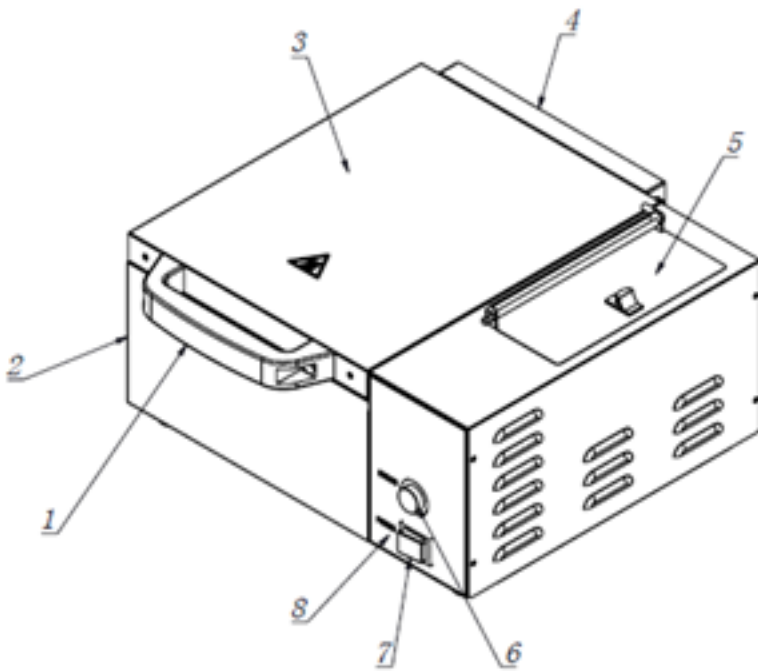

NO	PART NAME
1	Handle
2	Main Body
3	Cover
4	Rear Connecting Plate
5	Tank Cover
6	Steam Injection Button
7	Power Switch
8	Control Panel

## Installation of Your Steamer

1. QuickShot QS-1800 is 120V, 1800W and uses a 5-15P NEMA plug.
2. All electrical connections must comply with specifications and power standards. The installation must be done by qualified personnel.
3. All models are countertop type. Remove all exterior and interior packing materials, and place the steamer on a flat surface.
4. Place near an appropriate electrical outlet. Extension cords are not recommended.
5. Install legs onto unit.

## Before Using Your Steamer

**Before steaming anything in your steamer for the first time, please follow these simple instructions:**

1. Using a small amount of detergent, thoroughly wash the steamer.  
**NOTE:** Do not use a spray or abrasive polishing agent.
2. Gently wipe down the interior walls with a damp cloth.

## Using Your Steamer

1. Plug unit into a grounded outlet.
2. Open tank cover. Ensure filter is properly installed inside.
3. Fill unit with approximately 3 qt. of distilled water. To reduce calcium/mineral build-up, it is recommended to use distilled water. Do not overfill or use tap water.
4. Flip the on/off switch to the 'on' position. Allow the unit to preheat for 25 minutes.
5. Open top cover, and load product into the basket or half size perforated food pan. Close top cover.
6. Press steam button for 2 seconds. Release, and wait 20 seconds for steam to penetrate the product. Repeat as needed. Avoid pressing and holding the steam button for longer than 2 seconds, as it often floods out and hinders proper steaming.
7. Remove hot product from steamer.
8. Flip the on/off switch to the 'off' position.

**CAUTION: Foods steamed in this unit will be hot. Wear protective hand coverings when reaching into steamer to retrieve food.**

## Typical Operation Sequence

ACTION	RESULT
Plug in your steamer	Power is connected; unit will begin to heat
Load product into steamer	Product is ready to steam
Press steam button for 2 seconds, release, and wait 20 seconds	Unit fills body with steam, which penetrates the product
Unload steamer	Product will be hot; use caution removing it

## Cleaning & Maintaining Your Steamer

Daily cleaning is recommended for maximum service life. Do not immerse steamer in water or other liquid; it may cause the electrical components to short circuit or to produce an electrical shock.

### Daily Maintenance

1. Pour 1 Cup of White Vinegar into the tank
2. Cycle the steamer by pressing the steam button for 3-5 seconds, and wait 20 seconds between presses
3. After vinegar is cycled through, pour 1 Cup of Distilled Water into the tank, and continue to cycle until all vinegar is cleared from the internals of the steamer.

NOTE: White vinegar or similar solvent will help eliminate calcium and mineral build-up in the steamer. Without proper maintenance, the build-up will act as a thermal insulator leading to degraded performance and shortened lifespan.

4. Flip on/off switch to the "off" position. Disconnect power cord from electrical outlet.
5. Let steamer cool for 45 minutes.
6. Use a sponge or damp cloth and hot soapy water to wipe down unit
7. Rinse with clean, damp cloth
8. Wipe dry

### Weekly Maintenance

1. Follow steps 1-8 above
2. Open the steamer lid, remove pan and lift loose end of spray tube and pull it out of the generator hole
3. Slide off metal spray tube cover and remove water tank filter from water tank
4. Place the spray tube and water tank filter in a container and cover with white vinegar, let soak for 15 minutes

5. Remove the spray tube and water tank filter to examine if calcium or mineral deposits remain, then use a paper clip to remove any remaining build-up and rinse using vinegar and water.
6. Slide metal cover back onto the tube and replace water tank filter inside water tank
7. Pour 1 Cup of white vinegar onto the generator surface and let soak for 15 minutes
8. Rinse the generator surface and scrape off any remaining calcium or mineral build-up
9. Wipe generator clean with a damp cloth and reassemble unit and spray tube

**If excessive mineral deposits remain after cleaning, follow the directions below:**

1. Treat generator surface with a delimer solution. Follow all instructions and safety precaution as stipulated by the delimer's manufacturer. If using a chemical cleaner, make sure it is safe to use on the generator surface.
2. Remove delimer solution from generator with a sponge or dry towel. Rinse generator with clean water.

**NOTE:** Some calcium/mineral build-up is required on the generator surface for proper steaming. If all build-up is removed during cleaning, add distilled water to surface, and allow it to boil off. Repeat as needed until the generator surface is thinly coated in calcium/mineral deposits.

**NOTE:** It may be necessary to season the generator surface with lime if using soft water. Seasoning creates a thin coating of calcium/mineral deposits on the generator to ensure proper steaming.

To season, mix 3/4 oz. baking soda, 3/4 oz. lime, and 1 qt. water. Pour 1/4" deep onto hot generator surface. Allow the mixture to boil off. Remove any loose powder that remains.

3. Plug power cord into electrical outlet.
4. Flip the on/off switch to the 'on' position. Allow steamer to preheat for 30 minutes.
5. Press and release steam button several times to purge delimer residue from generator.
6. Flip on/off switch to the 'off' position. Reinstall parts and accessories.



## Parts List

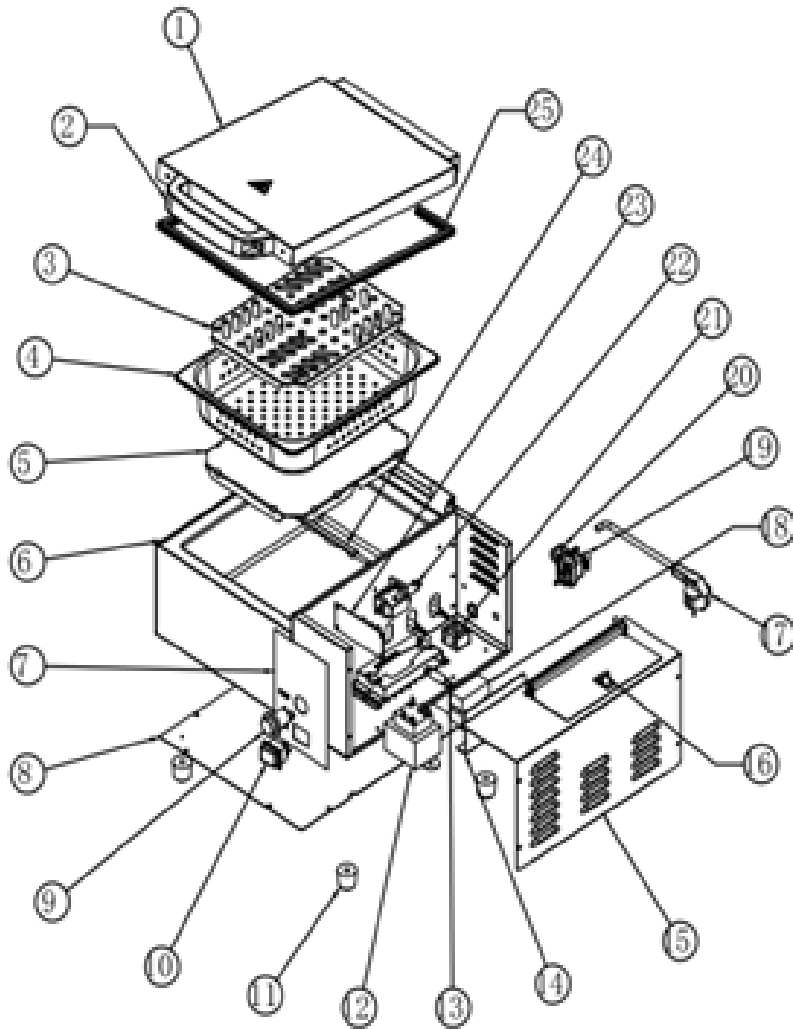

NO	PART NAME
1	Top Cover
2	Handle
3	Steam Plate
4	½ GN Pan
5	Evaporation Plate
6	Shell
7	Control Panel
8	Bottom Plate
9	Humidity Inching (steam switch)
10	Power Switch
11	Feet
12	Transformer
13	Spout Connector
14	Relay Fixing Plate
15	Right Plate for Water Tank
16	Water Tank Cover Lock
17	Power Cord
18	Relay
19	Temperature Limiter
20	Wire Buckle
21	Ceramic Terminal
22	Pump
23	Power Control Board
24	Water Pipe Fixture



# Equipment Limited Warranty

Avantco warrants its equipment to be free from defects in material and workmanship for a period of 1 year. This is the sole and exclusive warranty made by Avantco covering your Avantco brand equipment. A claim under this warranty must be made within **1 year** from the **date of purchase** of the equipment. Only the equipment's original purchaser may make a claim under this warranty. Avantco reserves the right to approve or deny the repair or replacement of any part or repair request. The warranty is not transferable. Avantco Equipment installed in/on a food truck or trailer will be limited to a period of **30 days** from the original date of purchase.

## To Make a Warranty Claim:

For Warranty Inquiries contact the location where you purchased the product:

- **WebstaurantStore.com:** Contact [help@webstaurantstore.com](mailto:help@webstaurantstore.com). Please have your order number ready.
- **The Restaurant Store:** If you purchased this unit from your local store, please contact your store directly.
- **TheRestaurantStore.com:** Online purchases, call 717-392-7261. Please have your order number ready.

Failure to contact the designated location prior to obtaining equipment service may void your warranty.

Avantco makes no other warranties, express or implied, statutory or otherwise, and **HEREBY DISCLAIMS ALL IMPLIED WARRANTIES, INCLUDING THE IMPLIED WARRANTIES OF MERCHANTABILITY AND OF FITNESS FOR A PARTICULAR PURPOSE.**

## This Limited Warranty does not cover:

- Equipment sold or used outside the Continental United States
- Use of unfiltered water (if applicable)
- Avantco has the sole discretion on wearable parts not covered under warranty
- Equipment not purchased directly from an authorized dealer
- Equipment used for residential or other non-commercial purposes
- Equipment that has been altered, modified, or repaired by anyone other than an authorized service agency
- Equipment where the serial number plate has been removed or altered.
- Damage or failure due to improper installation, improper utility connection or supply, and issues resulting from improper ventilation or airflow.
- Defects and damage due to improper maintenance, wear and tear, misuse, abuse, vandalism, or Act of God.

Any action for breach of this warranty must be commenced within 1 year of the date on which the breach occurred. No modification of this warranty, or waiver of its terms, shall be effective unless approved in a writing signed by the parties. The laws of the Commonwealth of Pennsylvania shall govern this warranty and the parties' rights and duties under it. Avantco shall not under any circumstances be liable for incidental or consequential damages of any kind, including but not limited to loss of profits.