

ADCRAFT®



COQ-1750W Quarter Size Convection Oven

This manual contains important information regarding your *Admiral Craft* unit. Please read the manual thoroughly prior to equipment set-up, operation and maintenance. Failure to comply with regular maintenance guidelines outlined in this manual may void the warranty. PLEASE READ!!!

WARNINGS

- Do not touch any hot surfaces
- Plug only into a 3-hole grounded electrical outlet
- Do not immerse unit, cord or plug in liquid at any time
- Unplug cord from outlet when not in use and before cleaning
- Do not operate unattended
- Do not use this unit for anything other than intended use
- Do not use outdoors
- Always use on a firm, dry and level surface at least 12" from walls or any other obstruction (top, rear, left and right)
- Do not use if unit has a damaged cord or plug, in the event the appliance malfunctions, or has been damaged in any manner
- Keep children and animals away from unit
- Any incorrect installation, alterations, adjustments and/or improper maintenance can lead to property loss and injury. All repairs should be done by authorized professionals only
- Ensure that the designated power supply is adequate for continual usage and the voltage is correct

TO USE

1. Remove all packing and protective plastic coating from the side panels.
2. Insert the plug into the socket.
3. Turn the power switch on.
4. Rotate the knob clockwise to set cooking time (timer indicator fan will turn on).
5. Immediately rotate the knob clockwise to set cooking temperature (heating indicator will turn on and begin to heat).
6. Heating indicator will shut off once the desired temperature is reached. The heating indicator will turn on again to maintain temperature.
7. An alarm bell will ring indicating that the timer has reached zero. The heating element will automatically shut off.

CLEANING – NOTE: To maintain cleanliness and increase service life, the oven should be cleaned daily. Do not immerse the unit in water or any other liquid. If liquid enters the electrical compartment it may cause a short circuit or electrical shock

- Disconnect the power cord from the electrical outlet.
- Allow unit to cool down.
- Clean with a good quality stainless steel compound.
- Clean the interior regularly with a good quality oven cleaner.
- Clean the oven door glass with conventional glass cleaner.
- Do not clean with a water jet stream.
- To avoid damage, do not use abrasive cleaners or scouring pads.
- If soap or chemical cleaners are used, be sure they are completely rinsed away with clear water immediately after cleaning. Chemical residue could damage or corrode the surfaces of the unit.

Convection oven
COQ-1750W
Circuit diagram

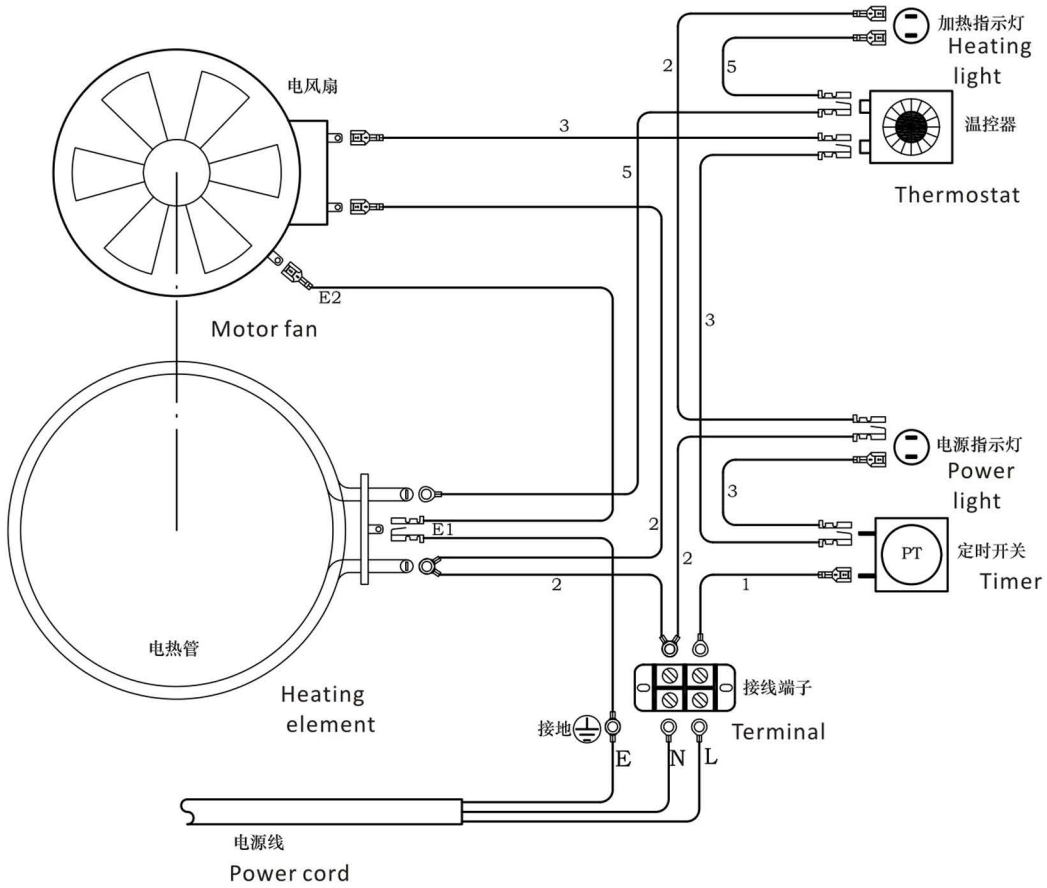
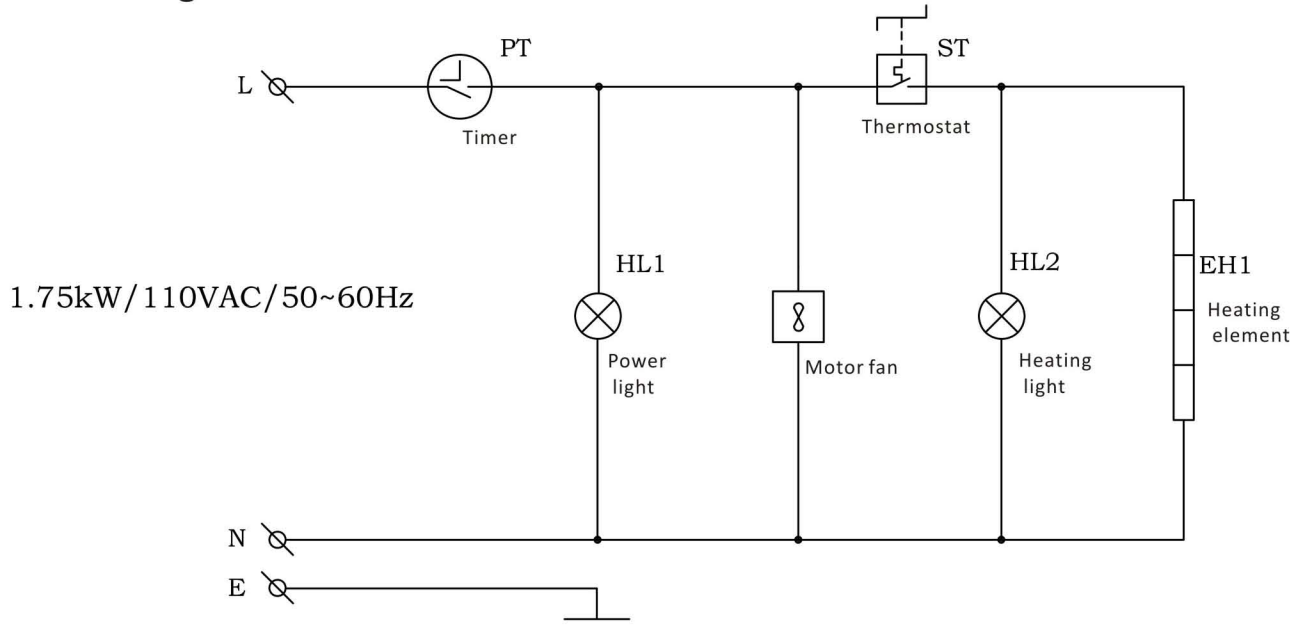

COQ-1750W

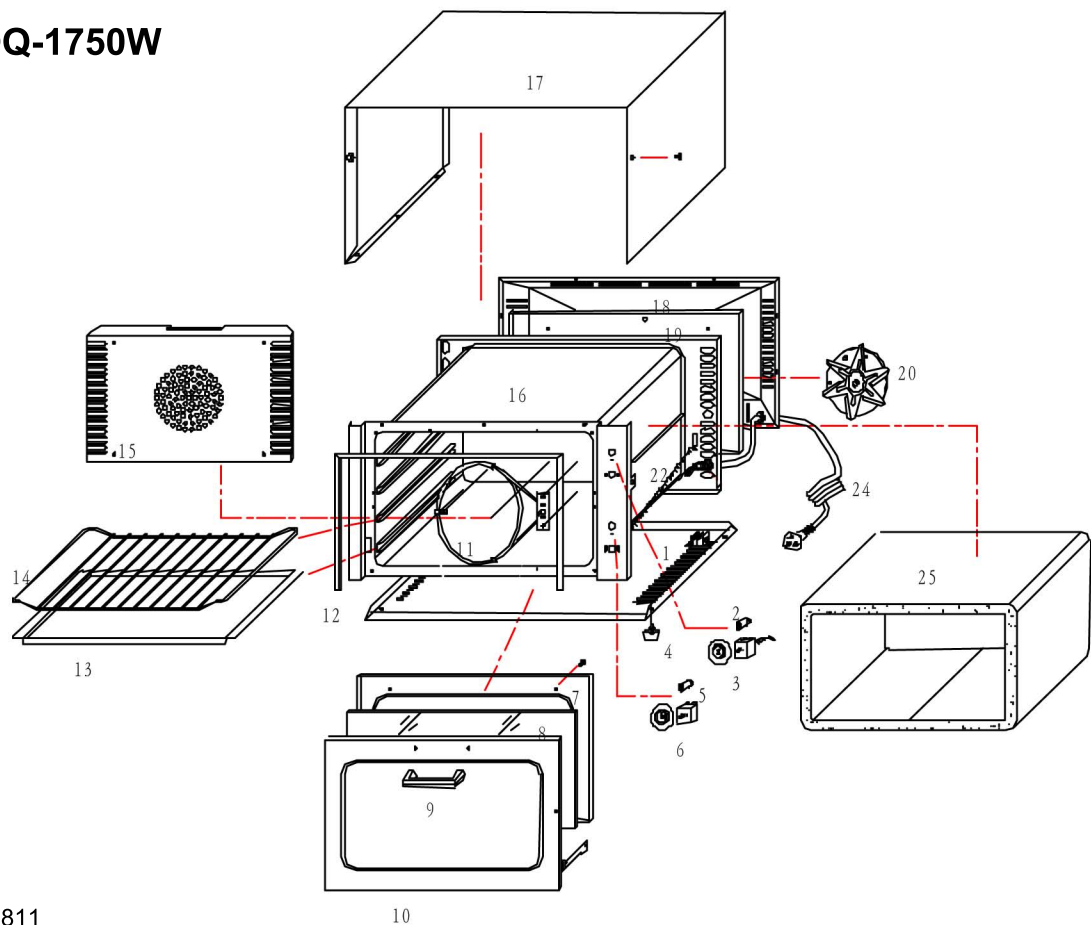

Quarter Size Convection Oven - COQ-1750W

Reference Number	Part Number	Description
1		Base Plate
2	COQ-2	Heating Indicator Light
3	COQ-3	Thermostat
4	COQ-4	Rubber Foot
5	COQ-5	Timer Indicator Light
6	COQ-6	Timer
7		Inner Plate for Door
8	COQ-8	Door Glass
9	COQ-9	Door Handle
10		Outer Plate for Door
11	COQ-11	Heating Element
12	COQ-12	Door Gasket
13	COQ-13	Tray
14	COQ-14	Grid
15		Airflow Plate
16		Shell Body
17		Outer shell
18		Back Cover
19		Heat Insulation Plate
20	COQ-20	Fan Motor
22	COQ-22	Spring
24	COQ-24	Power Cord and Strain Relief
25		Heat Insulation Cotton

VER811

ACE Electrical Equipment One Year Warranty

ACE warrants its equipment against defects in materials and workmanship, subject to the following conditions:

This warranty applies to the original owner only, and is not assignable.

ACE Electrical Equipment is warranted for one year, effective from the date of purchase by the original owner. A copy of the original receipt, or other proof of purchase is required to obtain warranty coverage.

Should any product fail to function in its intended manner under normal use within the limits defined in this warranty, at ACE's discretion, such product will be repaired, replaced with a refurbished unit, or replaced with a new unit by ACE, after defective unit has been inspected and defect has been confirmed. ACE does not assume any liability for extended delays in replacing any item beyond its control. This warranty does not apply to rubber and non-metallic synthetic parts where usage, wear, or lack of preventative maintenance may create abnormal replacement rates, and these parts are excluded from this limited warranty.

This warranty covers products shipped into the 48 contiguous United States, Hawaii, and metropolitan areas of Alaska and Canada. Warranty coverage on products used outside the 48 contiguous United States, Hawaii and metropolitan areas of Alaska and Canada may vary. Contact ACE for details at 1-800-223-7750

The following conditions are not covered by warranty:

- Equipment failure relating to improper installation, improper utility connection or supply and problems due to improper ventilation.
- Equipment that has not properly been maintained, damage for improper cleaning, and water damage to controls.
- Equipment that has not been used in an appropriate manner, or has been subject to misuse, neglect, abuse, accident, alteration, negligence, damage during transit, delivery or installation, fire, flood, riot, or act of God.
- Equipment that has the model number or serial number removed or altered.
- Equipment on which the security seal has been broken.

If the equipment has been changed, altered, modified, or repaired without express written permission from ACE, then the manufacturer shall not be liable for any damages to any person or to any property, which may result from the use of this equipment thereafter.

This equipment is intended for commercial use only. Warranty is void if equipment is used in other than a commercial application.

In the event your repair is not covered under the stated warranty provisions, parts are available by calling 1-800-223-7750. Equipment not covered by repair should be picked up from our warehouse facility within 10 business days from notification date. Any and all arrangements and expenses for the return of this merchandise is your responsibility.

“THE FOREGOING WARRANTY IS IN LIEU OF ANY AND ALL WARRANTIES EXPRESSED OR IMPLIED INCLUDING ANY IMPLIED WARRANTY OF MERCHANTABILITY OR FITNESS FOR PARTICULAR PURPOSES AND CONSTITUTES THE ENTIRE LIABILITY OF ACE. IN NO EVENT DOES THE LIMITED WARRANTY EXTEND BEYOND THE TERMS STATED HEREIN.”