



## INSTALLATION, OPERATION & MAINTENANCE

### AVANTCO SERIES 177AG OWNER'S MANUAL

Manual Griddles: 177AG24MG • 177AG36MG • 177AG48MG

Radiant Charbroilers: 177AG24RC • 177AG36RC • 177AG48RC

Hot Plates: 177AGR212 • 177AGR424 • 177AGR636

All equipment manufactured by Avantco is for use with the type of gas specified on the rating plate and for installation that will be in accordance with National Fuel Gas Code ANSI Z223.1 (latest edition).



**FOR YOUR SAFETY:** Do not store or use gasoline or other flammable vapors or liquids in the vicinity of this or any other appliance.



**WARNING:** Improper installation, adjustment, alteration, service or maintenance can cause property damage, injury or death. Read the installation, operating and maintenance instructions thoroughly before installing or servicing this equipment.



Instructions to be followed in the event the user smells gas must be posted in a prominent location in the kitchen area. This information shall be obtained from the local gas supplier.



PLEASE RETAIN THIS MANUAL FOR FUTURE REFERENCE

This equipment is design engineered for commercial use only.

# TABLE OF CONTENTS

Installation Instructions .....	2
Operating Instructions .....	3-4
Cleaning & Maintenance Instructions .....	5
Conversion .....	6
Specifications .....	7
Equipment Diagrams .....	8-16
Warranty .....	17

## INSTALLATION INSTRUCTIONS

- Installation of the equipment should be performed by qualified, certified and authorized personnel who are familiar and experienced with local installation codes.
- Before installation, please read instructions completely and carefully.
- Do not remove permanently affixed labels, warnings or plates from the product.

### SHIPPING DAMAGE CLAIM PROCEDURE

- 1. Visible loss or damage:** Note on freight bill or express delivery and have signed by person making delivery.
- 2. File claim for damages immediately:** Regardless of the extent of damages.
- 3. Concealed loss or damage:** if damage is noticed after unpacking, notify transportation company immediately and file “Concealed Damage” claim with the transportation carrier. This should be done within five (5) days from the date of delivery and receipt of goods. Retain container for inspection.

- Please observe all local and national codes and ordinances.
- Installation must conform with local codes, or in the absence of local codes, the National Fuel Gas Code, ANSI Z223.1 (latest edition). In Canada, installation should conform to installation codes for gas burning appliances and equipment standard CAN/CGA-B149.1 or the propane installation code, CAN/CGA-B149.2, as applicable.
- Electrical wiring to the appliance must be electrically grounded in accordance with local codes or in the absence of local codes with the National Electrical Code ANSI/NFPA 70, or the Canadian Electrical Code, CSA C22.2, as applicable.
- A manual gas shut-off valve must be installed in the gas supply line ahead of the appliance and gas pressure regulator for safety and ease in servicing.
- The gas pressure regulator supplied must be installed on the appliance prior to connecting the equipment to the gas line. Failure to install a regulator could be potentially hazardous and will void the appliance warranty.
- The appliance and its individual shut off valve must be disconnected from the gas supply piping system during any pressure testing of that system at test pressures in excess of ½ psi (3.45kpa).
- The appliance must be isolated from gas supply piping system, by closing its individual manual shut off valve during any pressure testing of the gas supply piping system at test pressures equal to or less than ½ psi (3.45kpa).

# OPERATING INSTRUCTIONS

Operation of this equipment must be performed by qualified or authorized personnel who have read and are familiar with the functions of the equipment.

## MAINTENANCE

To perform maintenance and repairs of the appliance, please contact the factory, the factory representative, or the nearest authorized local service company.

## RATING PLATE

Information on this plate includes the model, serial number, BTU/hour input of the burners, operating gas pressure in inches WC, and whether the appliance is orificed for natural or propane gas. When communicating with factory about a unit or requesting special parts or information, rating plate data is essential for proper identification.



**AVANTCO COOKING APPLIANCES MUST BE CONNECTED ONLY TO THE TYPE OF GAS IDENTIFIED ON THE RATING PLATE**



## CLEARANCES

The appliance area must be kept free and clear of all combustibles.

AVANTCO MODEL	Combustible		Non-Combustible	
	Rear	Sides	Rear	Sides
177AG (24/36/48) MG - Manual Griddles	8"	10"	0"	0"
177AG (24/36/48) RC - Radiant Charbroilers	8"	10"	0"	0"
177AGR (212/424/636) - Hot Plates	8"	10"	0"	0"

## AIR SUPPLY AND VENTILATION

The area in front of, around, and above the appliance must be kept clear to avoid any obstruction of the flow of combustion and ventilation of air.

Adequate clearance must be maintained around the appliance for easy servicing.

Provisions should be made for any commercial, heavy duty cooking appliance to have its exhaust combination waste products released to the outside of the building. The usual practice is to place the appliance under an exhaust hood, which should be constructed in accordance with local codes.

Strong exhaust fans in this hood or in the overall air conditioning system can produce a slight vacuum in the room and/or cause air drafts, either of which can interfere with the pilot or burner performance and could be difficult to diagnose. Air movement should be checked during installation. Air openings or baffles may have to be provided in the room, if pilot or burner outage problem persists.

## GAS CONNECTION

The gas supply (service) line must be the same size or greater than the inlet line of the appliance. Avantco appliances use a 3/4" NPT inlet. Sealant on all pipe joints must be resistive to LP gas.

## MANUAL SHUT OFF VALVE

This installer-supplied valve must be in the gas service line ahead of the appliance regulator in the gas stream and in position accessible in the event of an emergency.

## PRESSURE REGULATOR

Commercial cooking equipment must have a pressure regulator on the incoming service line for safe and efficient operation, since service pressures may fluctuate on local demand. A pressure regulator is packed inside every Avantco appliance.

### **FAILURE TO INSTALL THE PRESSURE REGULATOR WILL VOID THE APPLIANCE WARRANTY**

The regulators supplied along with Avantco appliances will have  $\frac{3}{4}$ " inlet/outlet openings.

Prior to connecting the regulator, check the incoming line pressure as these regulators can only withstand a maximum pressure of  $\frac{1}{2}$  psi (14" WC). If the line pressure is beyond this limit, a step down regulator will be required.

The arrow shown on the bottom of the regulator body shows the gas flow direction, it should point downstream to the appliance. The red air vent cap on the top is part of the regulator and should not be removed.

Any adjustments to the regulator should be made only by qualified service personnel with the proper equipment.

## CONNECTIONS

Please check installer-supplied intake pipes visually and/or blow them with compressed air to clear any dirt particles, threading chips, or any other foreign matter before installing a service line. When gas pressure is applied, these particles could clog orifices. All connections must be sealed with a joint compound suitable for LP gas, and all connections must be tested with a soapy water solution before lighting any pilots.



**CAUTION:** When lighting pilots and checking for leaks, do not stand with your face close to the combustion chamber.



## INITIAL PILOT LIGHTING

Check all gas connections for leaks with a soapy water solution before lighting any pilots.

### LIGHTING & SHUTDOWN

- Turn all valves to the OFF position.
- Wait for 5 minutes.
- Turn pilot valve(s) by adjusting the screw counter clockwise, then light standing pilot and adjust flame to  $\frac{1}{4}$ " high.
- Turn ON gas valve(s) to light the main burner.
- For complete shutdown, shut OFF gas valve(s) and turn pilot valve(s) by adjusting the screw clockwise to shut off gas to the pilot(s)

### BEFORE GRIDDLES 1<sup>ST</sup> USE

- Clean the griddle surface thoroughly with hot, soapy water to remove factory-applied protective oil coating.
- Rinse with a mixture of  $\frac{1}{4}$  cup vinegar to 1 qt. water.
- Spread unsalted solid shortening or liquid frying compound evenly over the entire griddle surface.
- Turn all griddle burners to medium and wait until the shortening begins to smoke, then turn the burners OFF.
- Rub the now melted shortening into the griddle surface with burlap, moving in the direction of the surface's polish marks and covering the entire surface.
- Allow the griddle to cool.
- When the griddle is cool after the second seasoning, wipe it with a thin film of shortening or cooking oil.

# CLEANING & MAINTENANCE INSTRUCTIONS

Any equipment works better and lasts longer when maintained properly. Cooking equipment is no exception. Your Avantco appliance must be cleaned on a daily basis.

## DAILY MAINTENANCE

### OPEN BURNERS

1. Remove all top grates.
2. Lift off the burner heads and venturi by raising the head slightly, sliding to the rear of the range, and lifting upwards.
3. Wash off the above in hot soapy water.
4. Reinstall burner parts in the reverse order.

### GRIDDLES

1. Scrape with a nylon griddle scraper to remove the cooked spills. When absolutely necessary, use a fine grained stone to scrape.
2. Wipe away any griddle stone dust and food particles with burlap.
3. Wash with hot, soapy water, then rinse with vinegar and water.
4. Rinse again with clear water.
5. Re-oil with shortening or liquid frying compound.
6. **DO NOT FLOOD A HOT GRIDDLE WITH COLD WATER.** This could cause warping and the griddle plate to crack.

### STAINLESS STEEL

All stainless steel body parts should be wiped regularly with hot soapy water during the day and with a liquid cleaner designed for this material at the end of each day. **DO NOT USE** steel wool, abrasive cloth, or powders to clean stainless surfaces. If it is necessary to scrape stainless steel to remove encrusted materials, soak in hot water to loosen the material, then use a wood or nylon scraper. **DO NOT USE** a metal knife, spatula, or any other metal tool to scrape stainless steel. Scratches are almost impossible to remove.

### PERIODIC CLEANING

Check the ventilation system periodically to see that nothing has fallen down into the stub back, high riser, or high shelf exhaust vents. Ensure your Avantco cooking equipment is checked by a qualified technician once a year for efficient and long-lasting operation of the appliance.

Contact the factory, factory representative, or a local service company  
to perform all Maintenance & Service Repairs

# CONVERSION

Instructions are for conversion from Natural Gas to Propane (L.P.) on all models. The conversion should be done before connecting the unit to the gas supply. Units are shipped from the factory equipped for use on natural gas. Orifices necessary for LP (propane) are provided in a bag tied to the valve on the front panel.

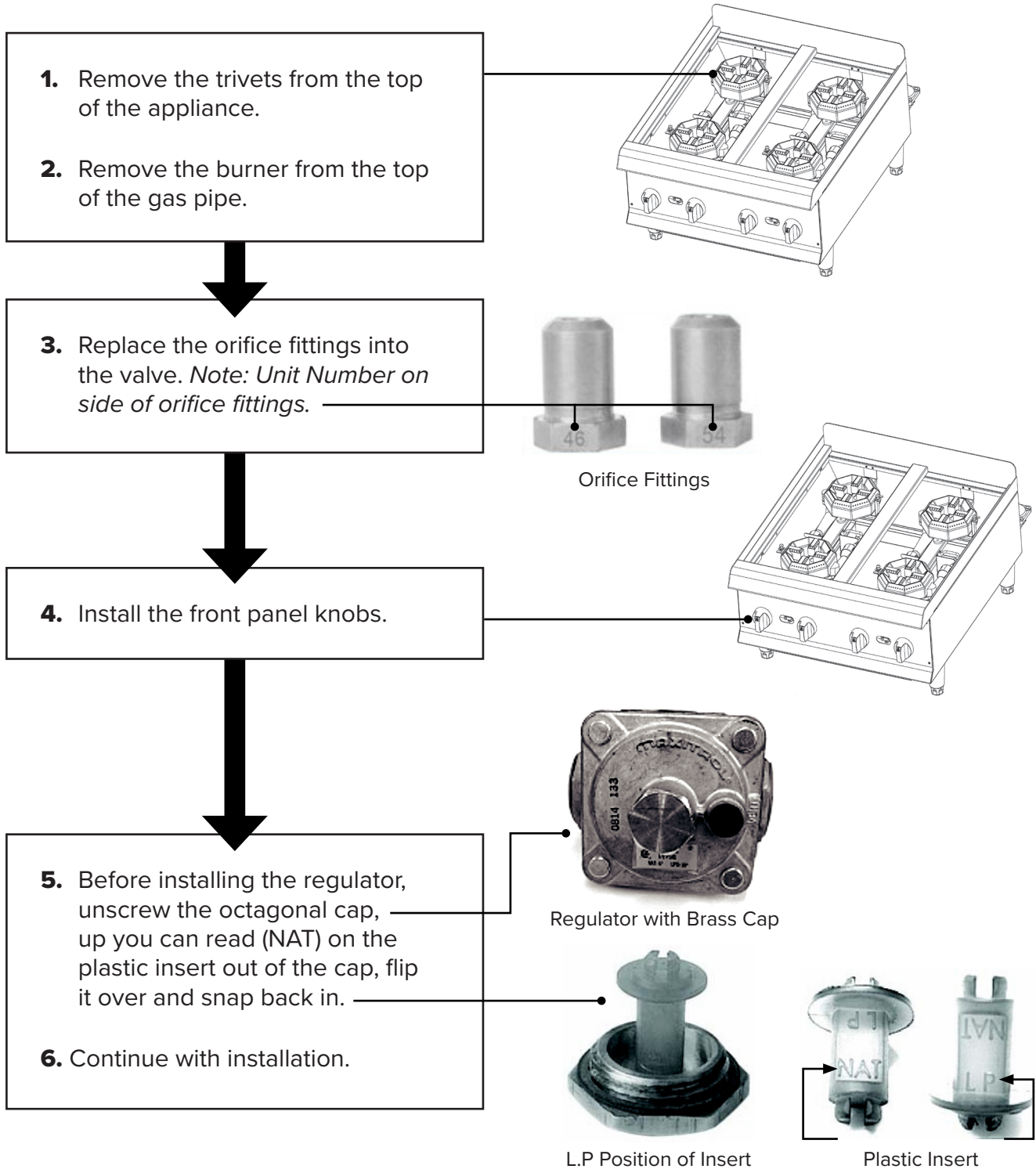

## COUNTERTOP EQUIPMENT SPECIFICATIONS

Model	# of Burners & Controls	Gas Type	Intake-Tube Pressure (in.W.C.)	Per BTU B.T.U./h	Total BTU B.T.U./h	Nozzle
<b>177AG24RC</b>	2 Independent	Natural Gas	4	35,000	70,000	#36
		L.P. Gas	10	35,000	70,000	#50
<b>177AG36RC</b>	3 Independent	Natural Gas	4	35,000	105,000	#36
		L.P. Gas	10	35,000	105,000	#50
<b>177AG48RC</b>	4 Independent	Natural Gas	4	35,000	140,000	#36
		L.P. Gas	10	35,000	140,000	#50
<b>177AG24MG</b>	2 Independent	Natural Gas	4	30,000	60,000	#37
		L.P. Gas	10	30,000	60,000	#51
<b>177AG36MG</b>	3 Independent	Natural Gas	4	30,000	90,000	#37
		L.P. Gas	10	30,000	90,000	#51
<b>177AG48MG</b>	4 Independent	Natural Gas	4	30,000	120,000	#37
		L.P. Gas	10	30,000	120,000	#51
<b>177AGR212</b>	2 Independent	Natural Gas	4	25,000	50,000	#43
		L.P. Gas	10	25,000	50,000	#53
<b>177AGR424</b>	4 Independent	Natural Gas	4	25,000	100,000	#43
		L.P. Gas	10	25,000	100,000	#53
<b>177AGR636</b>	6 Independent	Natural Gas	4	25,000	150,000	#43
		L.P. Gas	10	25,000	100,000	#53

# 177AGR212 DIAGRAM

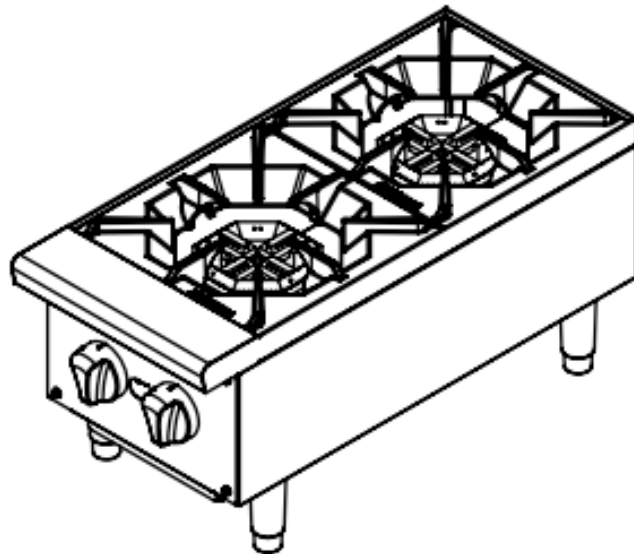
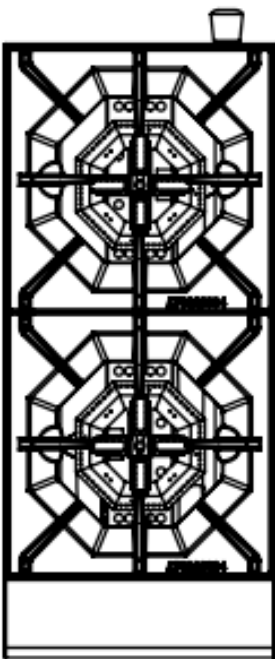
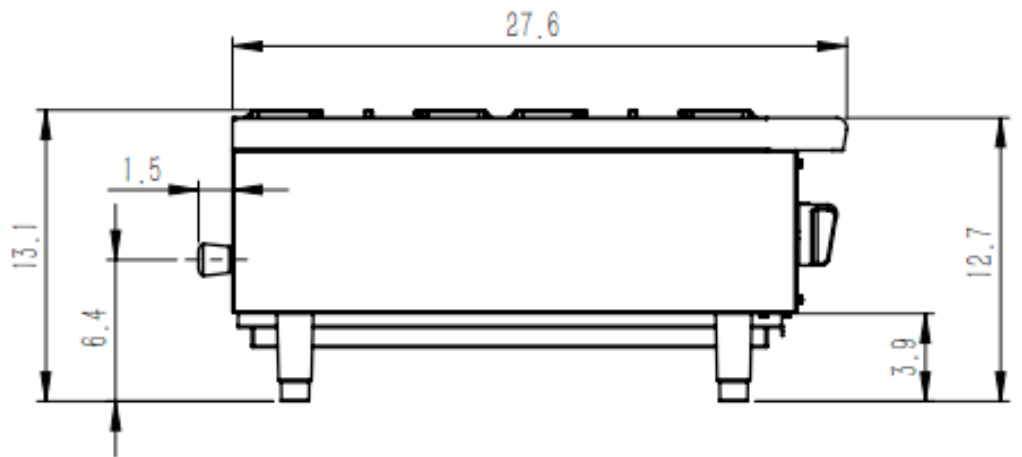
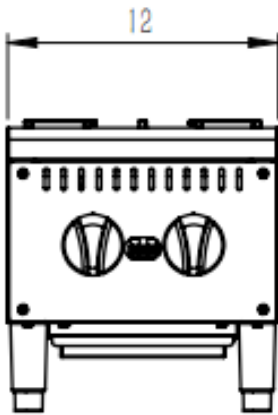



# 177AGR424 DIAGRAM

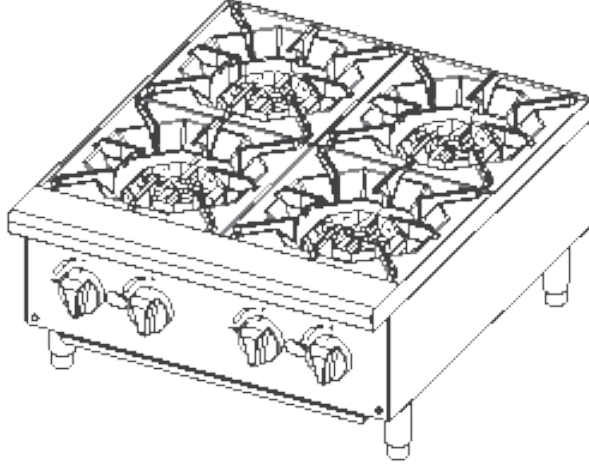
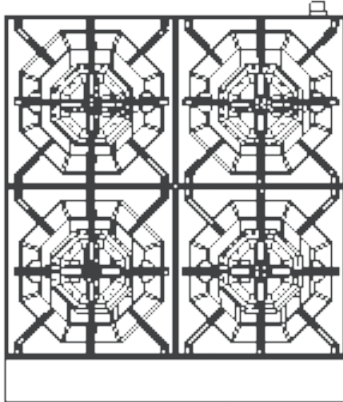
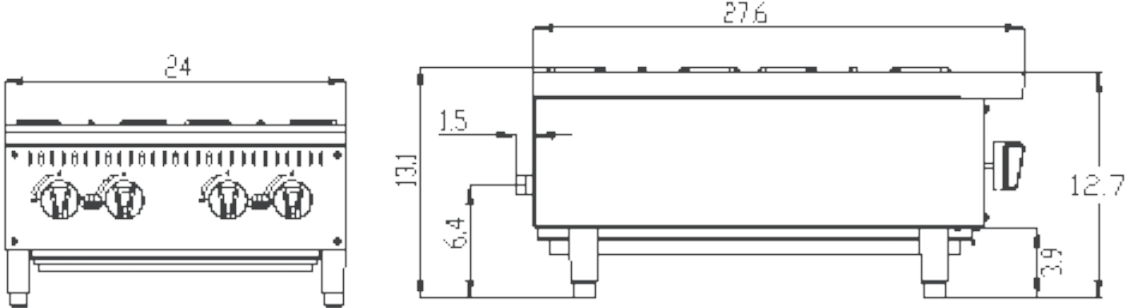

# 177AGR636 DIAGRAM

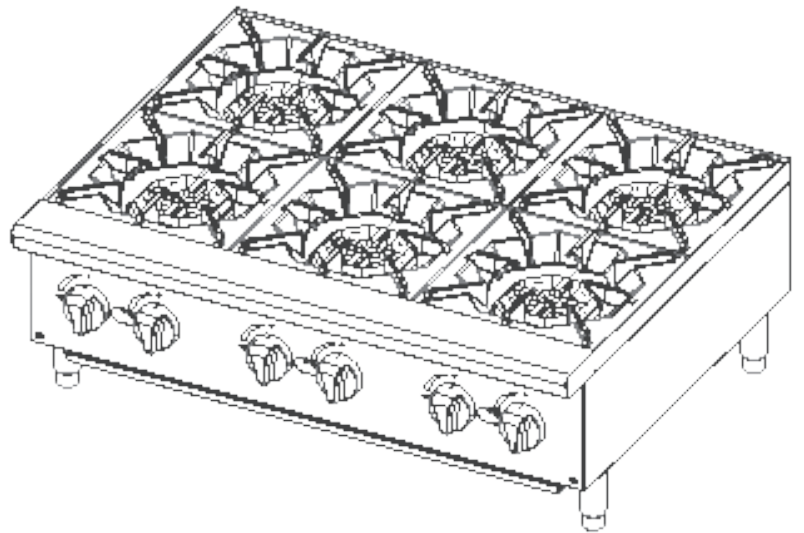
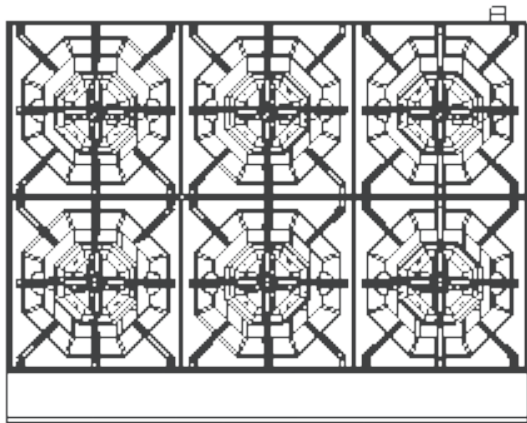
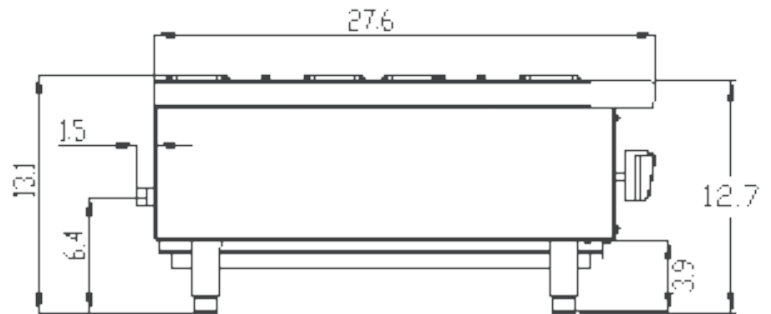
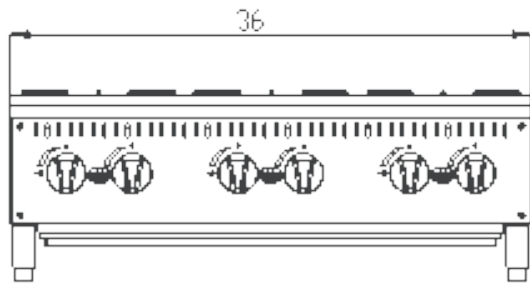

# 177AG24MG DIAGRAM

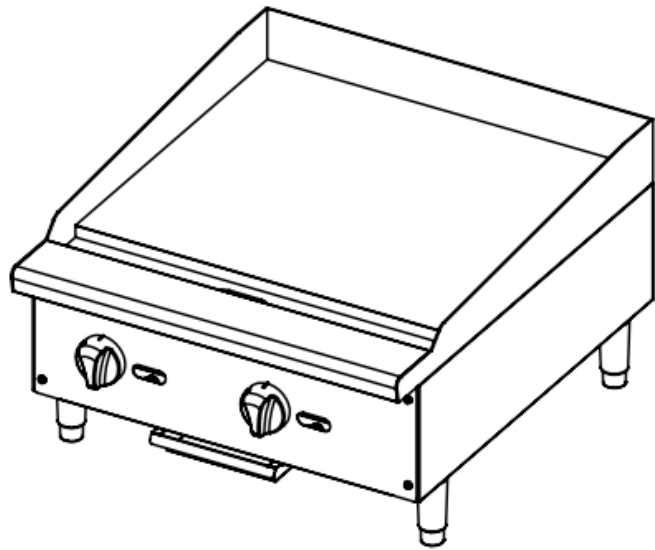
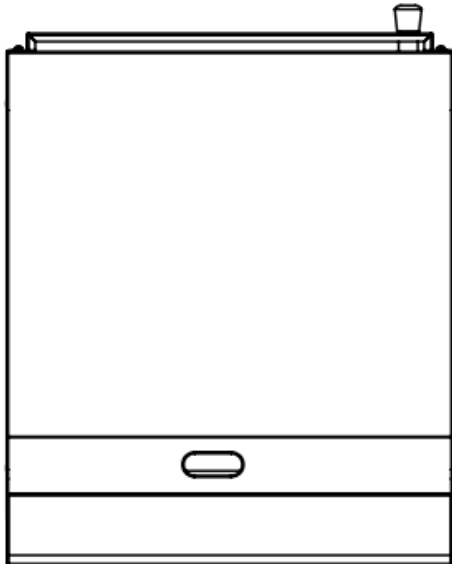
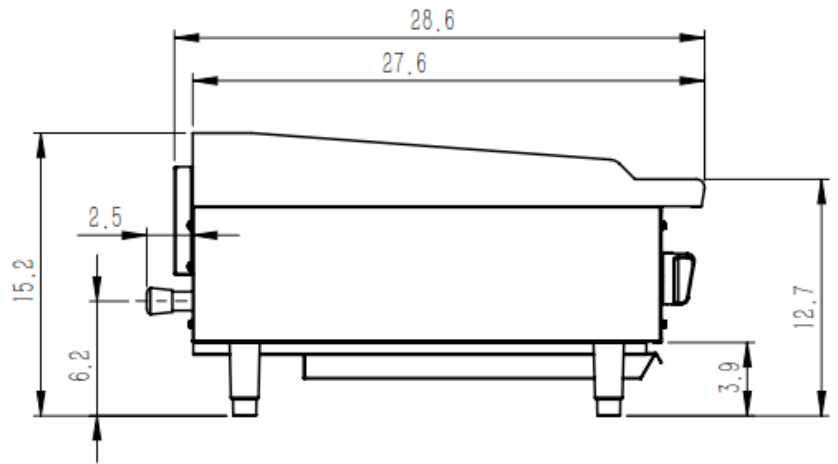
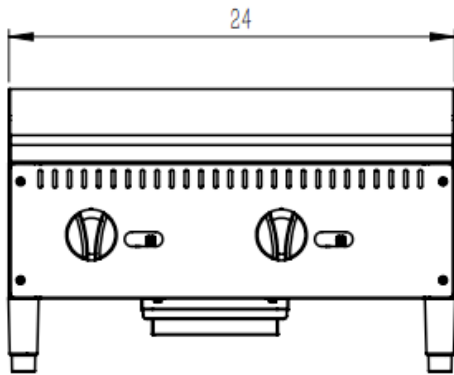

# 177AG36MG DIAGRAM

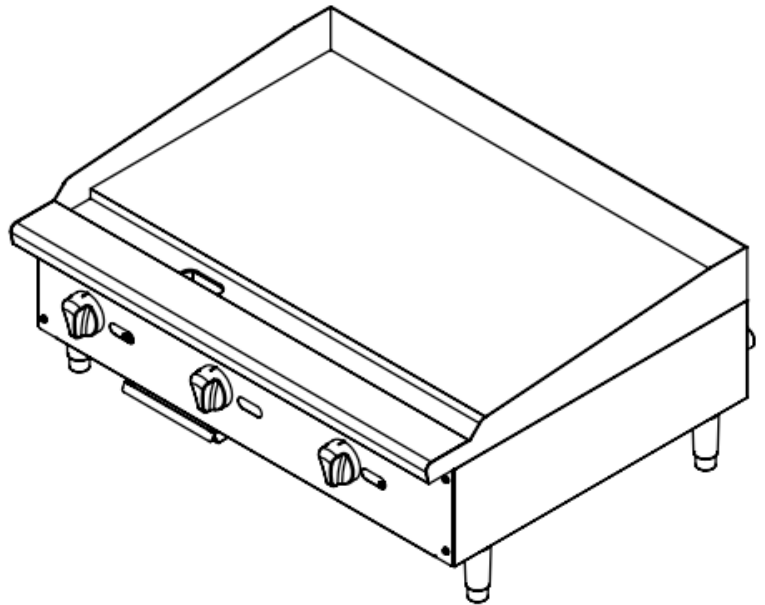
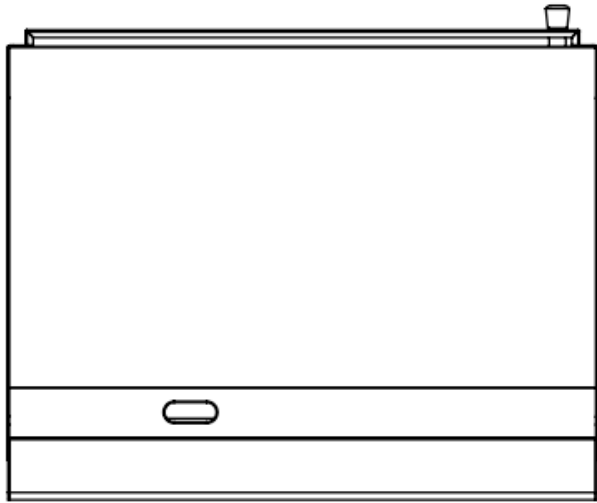
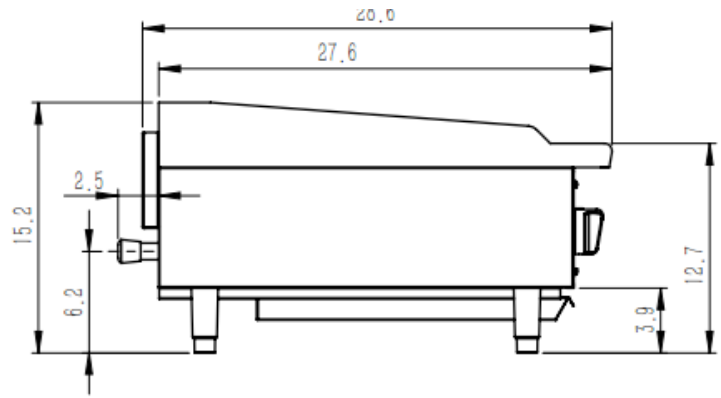
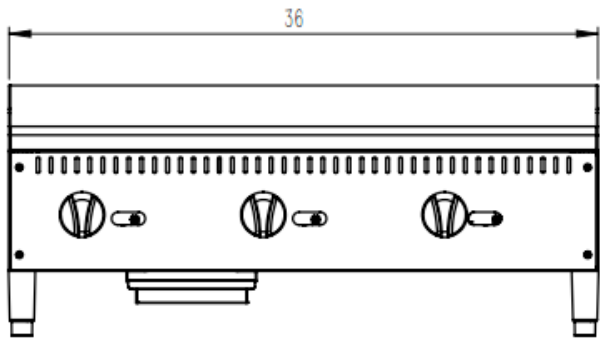

# 177AG48MG DIAGRAM

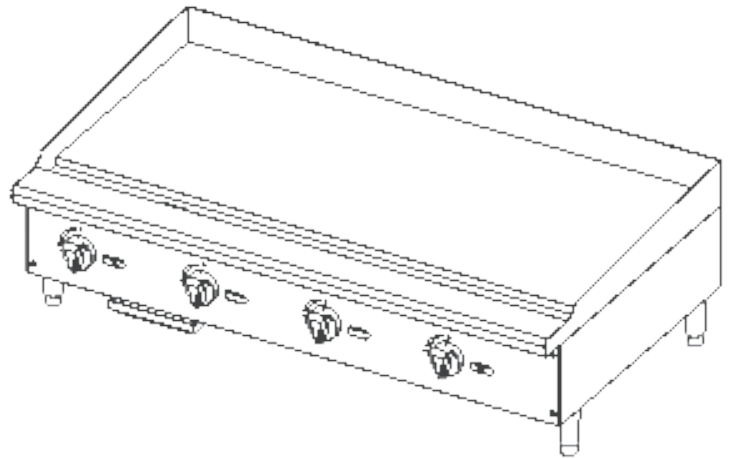
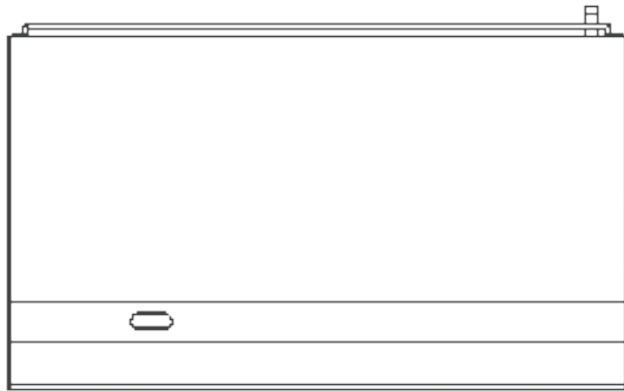
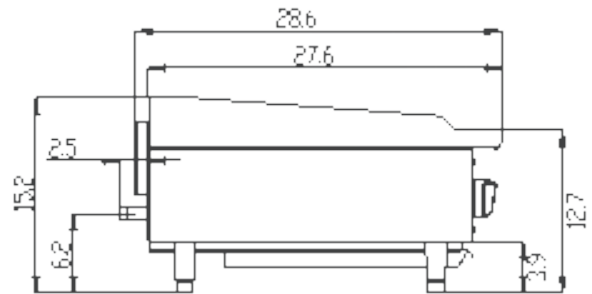
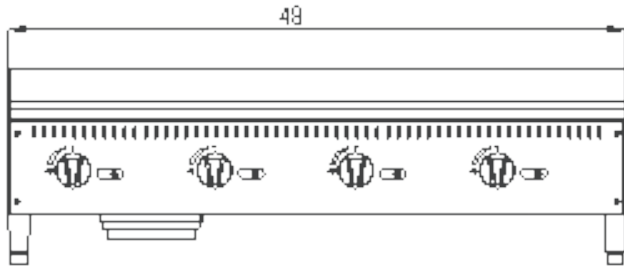

# 177AG24RC DIAGRAM

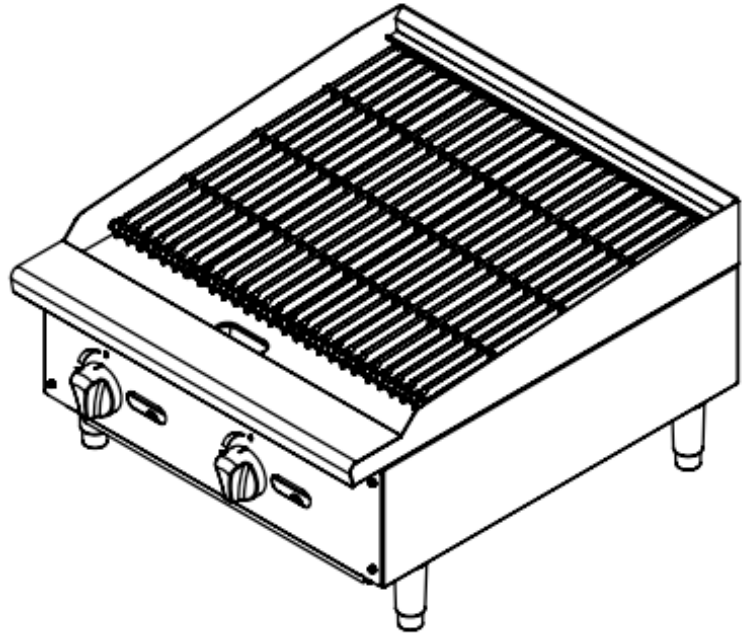
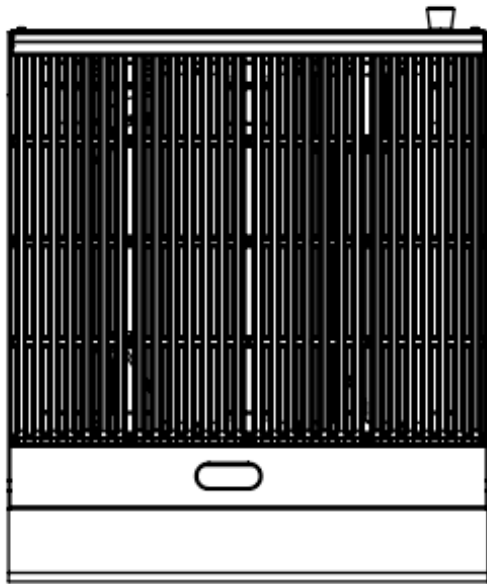
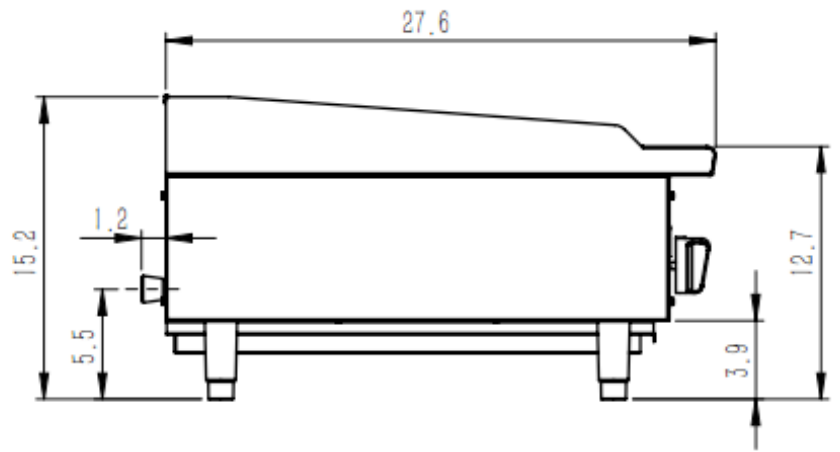
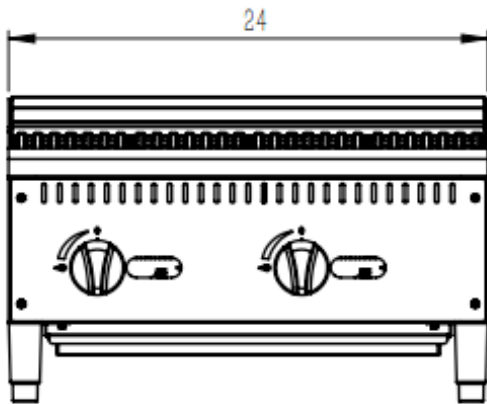

# 177AG36RC DIAGRAM

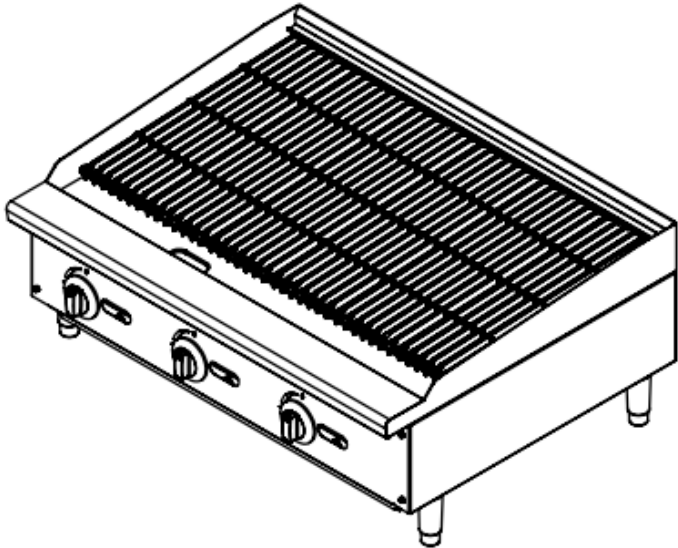
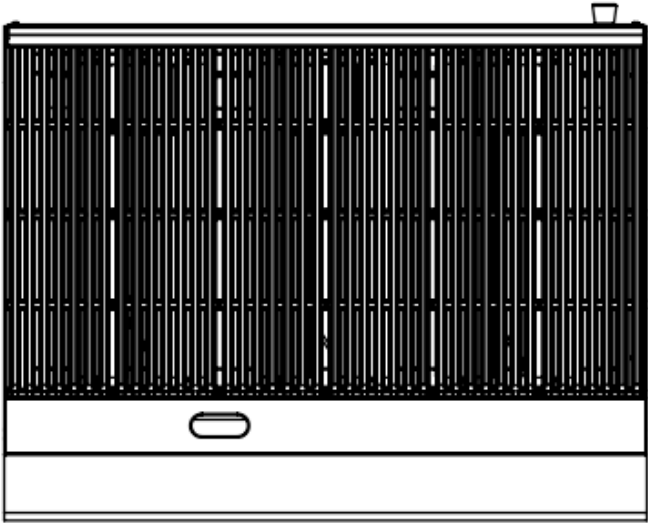
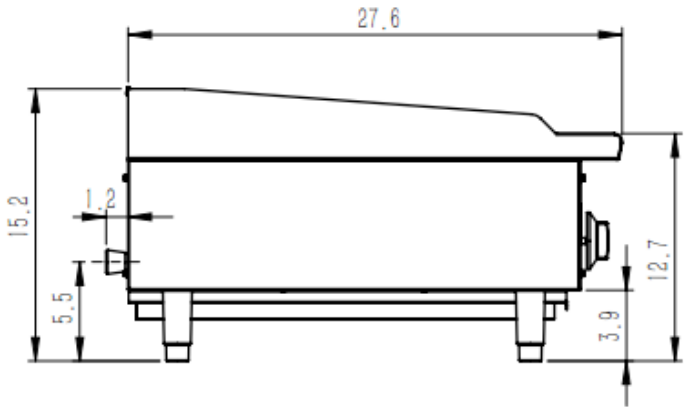
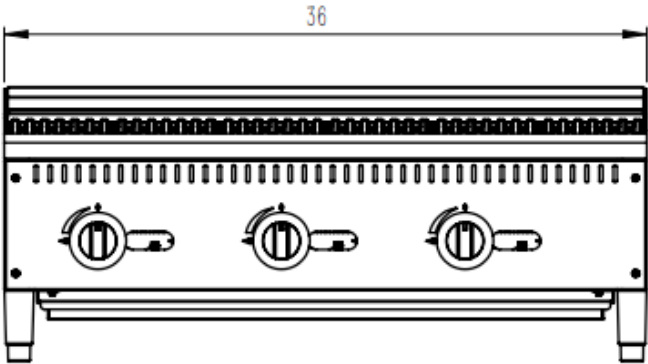

# 177AG48RC DIAGRAM

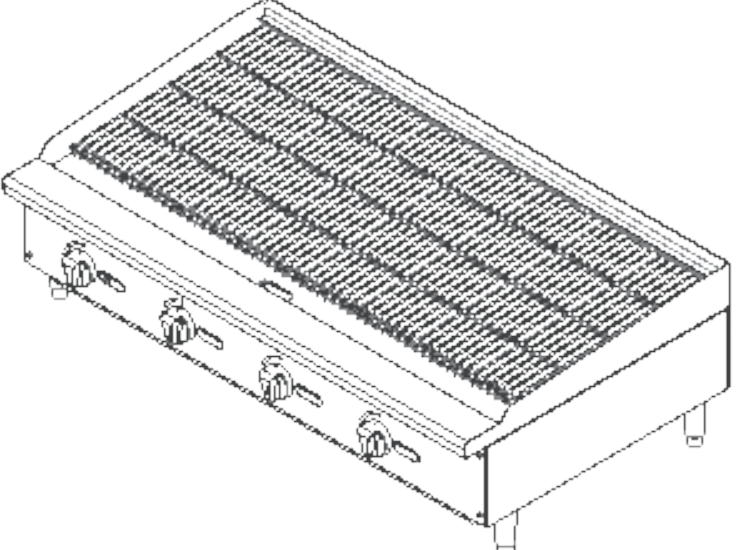
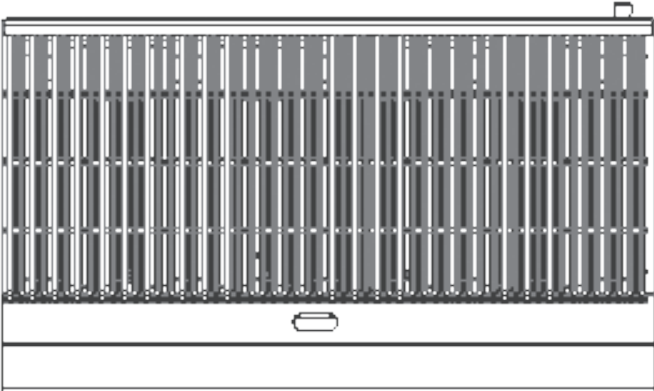
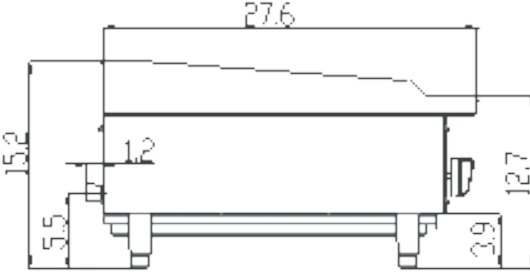
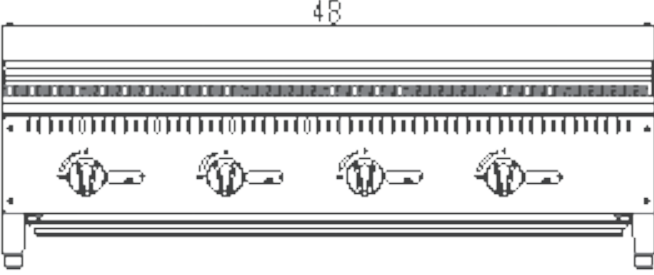





## LIMITED WARRANTY

### AVANTCO EQUIPMENT MODELS

Manual Griddles: 177AG24MG • 177AG36MG • 177AG48MG

Radiant Charbroilers: 177AG24RC • 177AG36RC • 177AG48RC

Hot Plates: 177AGR212 • 177AGR424 • 177AGR636

All new Avantco Griddles, Charbroilers and Hot Plates used for commercial purposes are warranted against defects in materials and workmanship under normal use and maintenance. The warranty runs for six (6) months from the date of original installation and is for the benefit of the original purchaser only. All other warranties, expressed or implied, statutory or otherwise, including without limitation any implied warranty of merchantability for fitness for purposes are excluded. The seller shall in no event be liable for direct, indirect or consequential damages in connection with Avantco commercial products.

#### EXCLUSIONS:

- The following conditions are not covered by warranty:
- Equipment damage or equipment failure occurs because of accident, carelessness, lack of proper set-up, supervision when required, or if the equipment is installed or operated in any manner contrary to the installation and operating instructions.
- Equipment damage or equipment failure due to improper installation, improper utility connection or supply, and problems due to ventilation.
- Equipment that has not been used appropriately, or has been subject to misuse, neglect, abuse, accident, alteration, negligence, damage during transit, delivery or installation, fire, flood, or act of God.
- Equipment that has the model number or serial number removed or altered.
- Equipment that has been changed, altered, or modified or repaired by other than an Authorized Service Agency. Avantco shall not be held liable for any damages to any person or property which may result from the use of the equipment thereafter.

This warranty does not apply to, and Avantco is not responsible for, any warranty claims on products sold or used outside of the contiguous United States.

This equipment is intended for commercial use only. Warranty is void if equipment is installed in other than commercial applications.