

# Boomerang Chair

ASSEMBLY INSTRUCTIONS



**LANCASTER**  
TABLE & SEATING

**A** Frame 1/PC

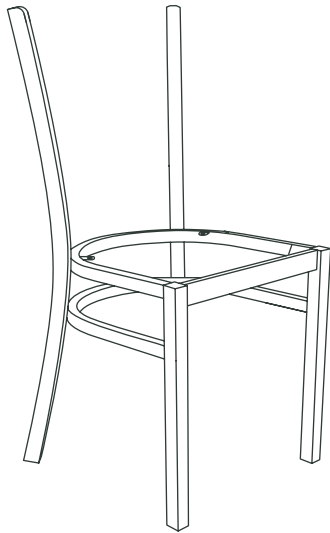

**B** Wood Seat 1/PC



Vinyl Seat 1/PC



OR

**C** Backrest 1/PC

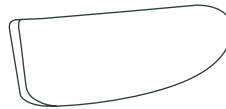

Only two pilot holes on backrest

**D** Backrest Bolts  
2/PC



**E** Backrest Screws  
2/PC



**F** Seat Screws  
(short screws) 4/PC



**REQUIRED TOOLS:**

• Screwdriver

**NOTES:**

1. Inspect all pieces for damage before assembly. Do not assemble if any pieces are broken or damaged. Ensure you have all required pieces before assembly.
2. Power drill is optional for assembly.
3. There are two options for Step 1, please reference both steps for your preference.

**STEP 1**

**Option 1:** Place chair frame (A) on its back. Center seat (B) on the frame with four screw holes, push cushion against frame, ensuring front of seat is parallel with the front of the frame.

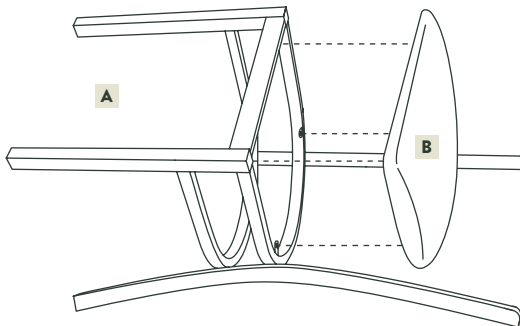

**Option 2:** Place seat (B) upside down on flat surface, preferably a table. Center seat (B) on the frame, aligning the four screw holes. Push the seat against frame, ensuring the front of seat is parallel to the front of the frame.

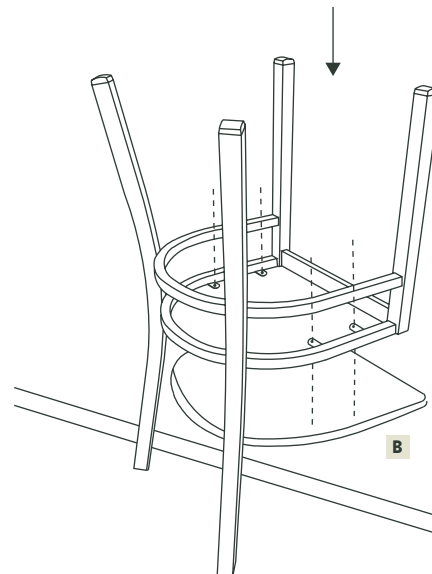

OR

# Boomerang Chair

ASSEMBLY INSTRUCTIONS



LANCASTER™  
TABLE & SEATING

## STEP 2

Attach seat (B) to frame (A) with four seat screws (E) using a screwdriver or power drill. Ensure all screws are tightened fully. Stand chair upright.

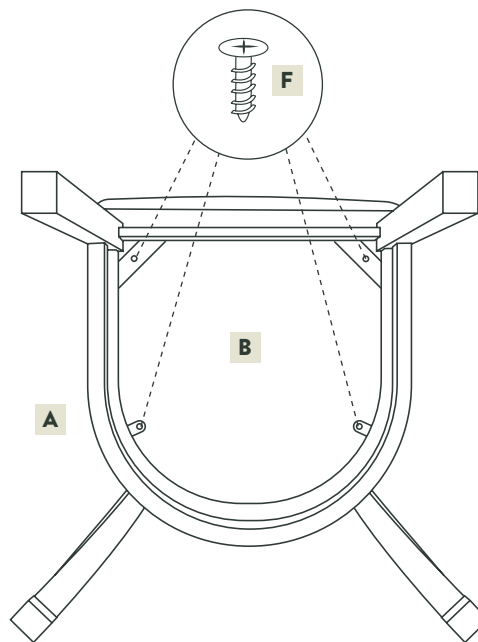

## STEP 3

Attach backrest (C) to frame (A) with the pre-drilled pilot holes aligned with the top holes on the frame. Use the two backrest bolts (D) to attach the backrest to the frame. Insert the backrest screws (E) into the bottom two holes in the frame. The holes for the screws are not predrilled in the backrest. Use a screwdriver or power drill to tighten the bolts and screws fully.

