



Unit Information

Model	Watts	Out Put Slices Per Hour	Plug Type
CTS1000 CTS10006	1800	450	
CTS1000C	1800	450	

2" Opening Accommodates Thick Bread and Bagels
5 Minute Heat Up Time

WARING COMMERCIAL

Conveyor Toaster

CTS1000 / 3.5 foot cord

CTS10006 / 6 foot cord

CTS1000C / Canada

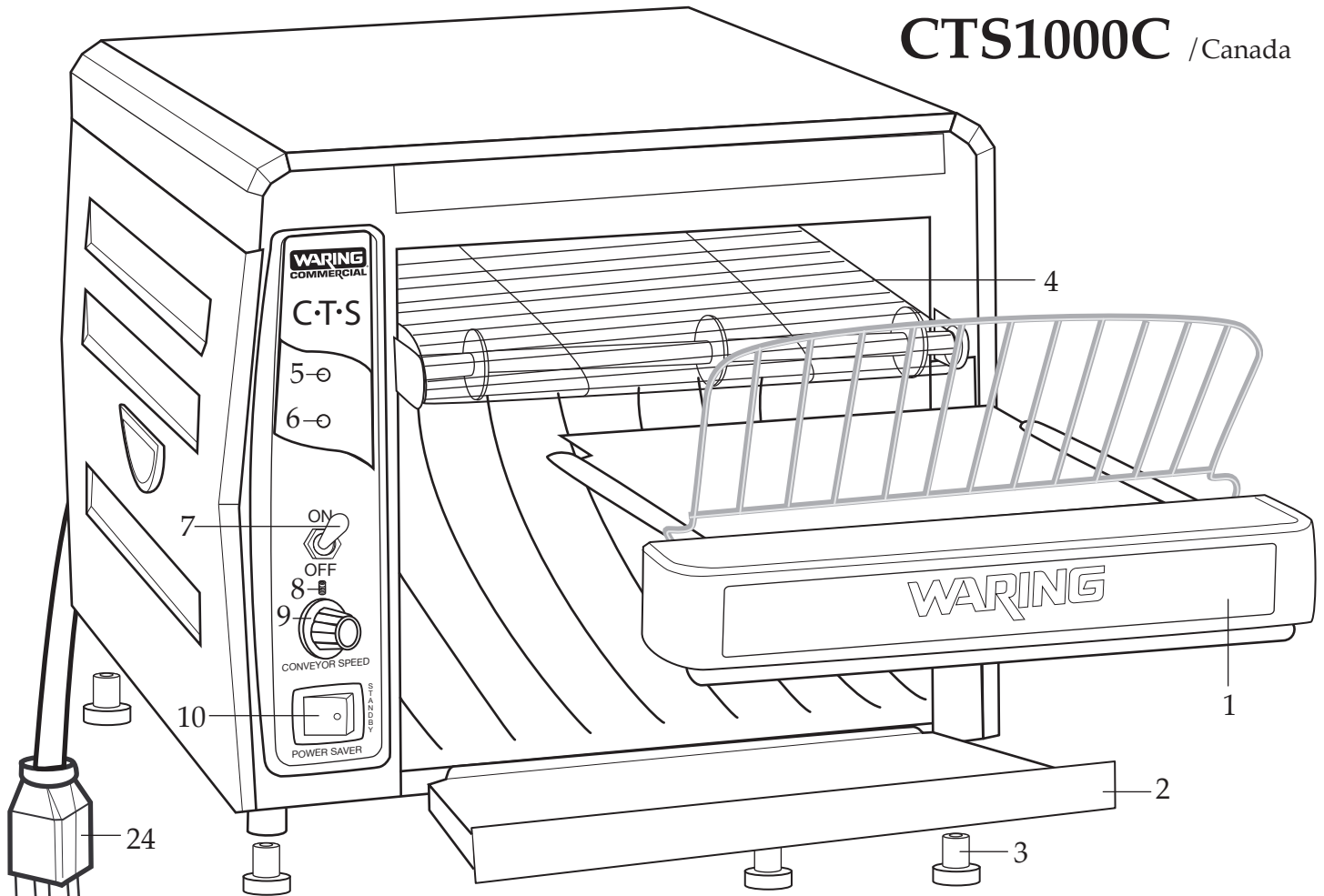

503163 - Unit Assembly CTS1000 • **503282** - Unit Assembly CTS10006 • **503206** - Unit Assembly CTS1000C

Internal Components

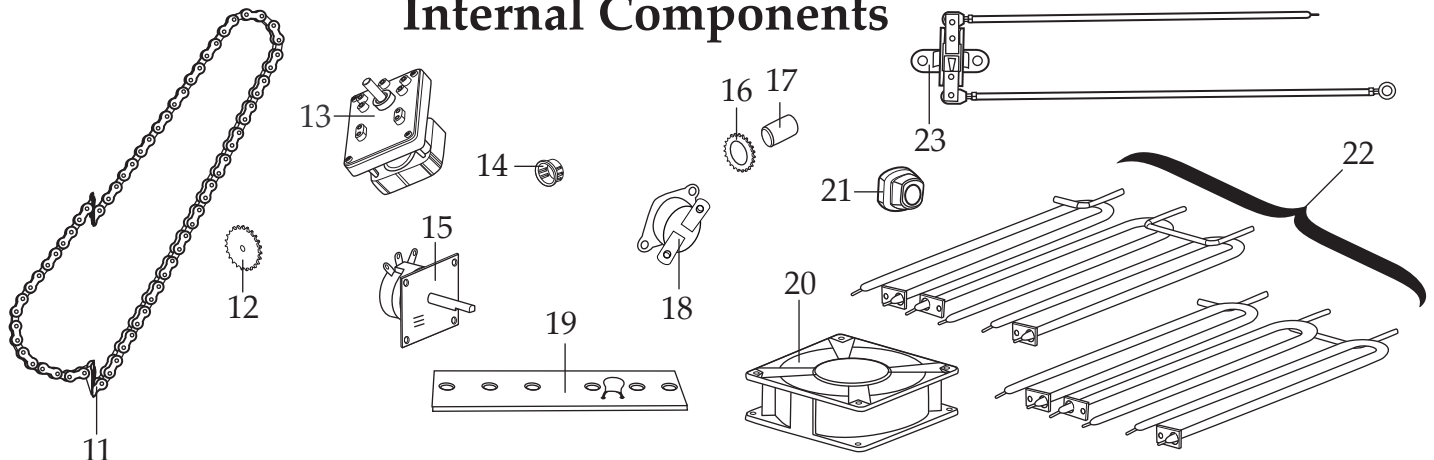

Catalog/Model

CTS1000
CTS10006
CTS1000C

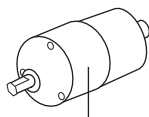

Illustration #	Part #	Description
1	028863	Crumb Tray
2	032930 028864	Toaster Drawer (<i>current</i>) Toaster Drawer
3	028865	Foot 4 Req.'d
4	029683	Conveyor Belt
5	029684	LED Cover Red
6	029685	LED Cover Green
7	029769	Toggle Switch - On/Off
8	029235	Set Screw
9	029105	Conveyor Speed Knob
10	029768	Rocker Switch - Standby
11	032721 029688	Chain /62 pitch Chain /68 pitch
12	032719	Motor Sprocket
13	032779	Motor / AC
14	029691	Clamp Bushing / nylon
15	032720	VR PCB Assy.
16	029694	Conveyor Sprocket
17	029695	Space Tube 2 Req.'d
18	029772	Thermo Switch
19	029697	Power Connection PCB Assy.
20	029773	Fan Assy.
21	029700	Cable Clamp / strain relief
22	029774	Heater / set of 2-upper & 2-lower Replaceable (<i>starting with a date code of October 2011</i>)
23	030208	Temperature Sensor
24	029847 029799 029848	Cord / CTS1000 Cord / CTS10006 Cord / CTS1000C

Older Unit Parts



029689 - Motor Sprocket / large



029770 - Motor / DC



029771 - Transformer

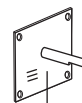

029692 - Main PCB Assy.
no longer available