



## Efficiency, economy and performance in one package

One of the most economical radiant tube heaters on the market for heating distribution and production facilities. Built using Schwank's low cost heating system design, the **builderSchwank** energy efficient heater provides comfort and a quick payback period.

### Also Available in 2-Stage [SET] Model

Schwank 2-Stage builder series heater adjusts heat output to meet changing heating needs. This heater lowers energy consumption and increases equipment life by reducing ON-OFF cycles by up to 35%.

**Experience Counts:** Schwank is the worldwide market leader and most trusted brand with over 2 million heating appliances sold.



## Features

- Line voltage and 24 volt thermostat ready
- Whisper-Jet technology makes heater extremely quiet
- Easy access to "clamshell" burner box
- Reflector & end caps improve IR heat
- Emissive coated tubes

### Optional Accessories [See back for more details.](#)

- Air Intake Wall Cap
- Horizontal Flue Vent Terminal
- Elbow Kit

**Contact us today for a FREE design and quote!**

# builderSchwank - Technical Specifications, Controls, & Accessories

Information below is intended only as a reference and should not be used when installing equipment. Please ensure you locate the most recent instruction manual for accurate and up to date information.

## Clearances to Combustibles

### S100 Straight Tube System

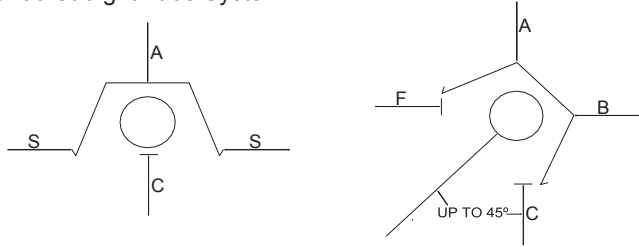

### \*P40U Packaged U-Tube

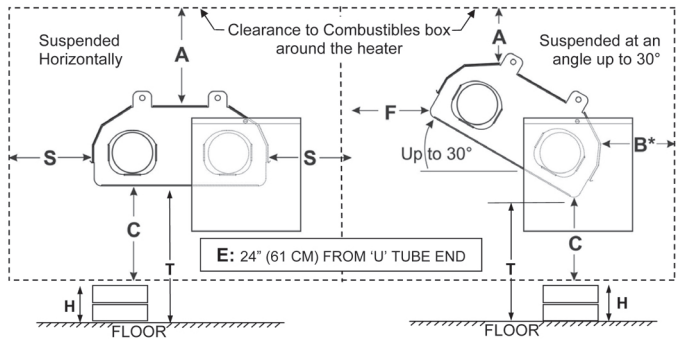

MODEL	SUSPENDED HORIZONTALLY			SUSPENDED AT AN ANGLE UP TO 45°			
	A	S	C	A	B	F	C
S100 [U] 200	14"	44"	76"	13"	6"	74"	70"
S100 [U] 175	13"	42"	74"	12"	6"	72"	68"
S100 [U] 155	11"	34"	70"	10"	4"	50"	64"
S100 [U] 130	10"	32"	65"	10"	3"	45"	60"
S100 [U] 110	9"	30"	60"	9"	3"	36"	54"
S100 [U] 100	11"	32"	68"	10"	4"	57"	68"
S100 [U] 80	7"	24"	42"	7"	2"	31"	38"
S100 [U] 60	7"	20"	34"	7"	2"	25"	34"
S100 [U] 45	7"	16"	32"	7"	2"	29"	32"
P40U*	12"	24"	55"	12"	12"	36"	55"

## Flexible Layout

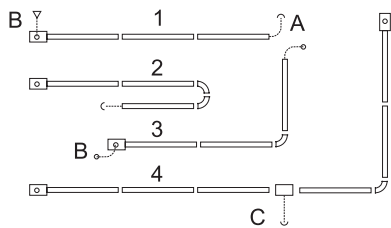

### System Configuration

1. Straight line
2. "U" tube with two 90° elbow kits
3. "L" tube with 90° elbow kit
4. Common 6" TEE flue vent

### Venting Options

- A. 4" flue vent through wall or roof
- B. 4" intake air from wall or roof
- C. 6" common vent through wall or roof

Distributor Information:

## Dimensions and Specifications

### S100 Straight Tube System

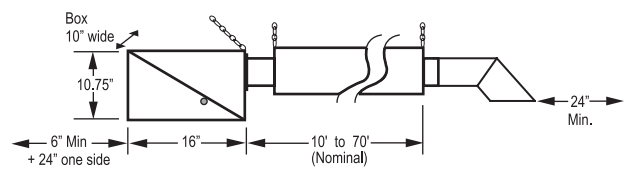

### \*P40U Packaged U-Tube

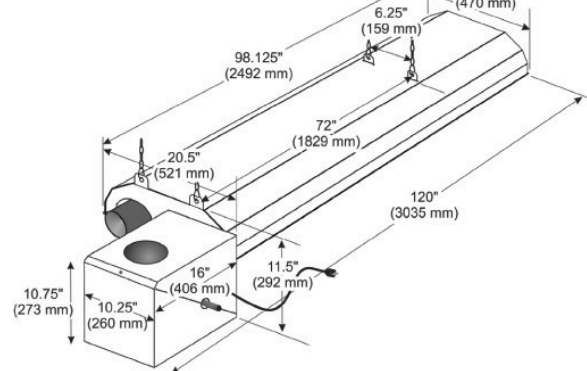

MODEL	INPUT BTU/HR U.S.A.: SEA LEVEL TO 2,000' CANADA: SEA LEVEL TO 4,500'	AVAILABLE LENGTH						
		10'	20'	30'	40'	50'	60'	70'
S100 200	200,000					•	•	•
S100 175	175,000					•	•	•
S100 155	155,000				•	•	•	
S100 130	130,000				•	•		
S100 110	110,000				•	•		
S100 100	100,000		•					
S100 80	80,000		•	•	•			
S100 60	60,000		•	•				
S100 45	45,000		•					
P40U*		•						
HEATER LENGTH		10' 0"	21' 0"	30' 8"	40' 4"	50' 0"	59' 8"	69' 4"
SHIPPING WEIGHT [LBS.]		100	150	200	240	315	360	430

\*HIGH ALTITUDE: De-rate heater 4% for each additional 1,000 Ft. of elevation

Gas pressure	Line minimum:	5" W.C. NG	11" W.C. LP
	Line maximum:	14" W.C. NG	14" W.C. LP
	Manifold:	3.5" W.C. NG	10" W.C. LP
Gas inlet	1/2"		
Flue & air vent	4"		
Electrical	120V, 60 Hz, 1.5 AMPS		

## Optional Accessories

Fresh air intake wall cap	JS-0532-VC
4" Horizontal flue vent terminal (wall)	JA-0528-XX
90° Elbow kit with reflector cap (Combine with two 90° to create 180° elbow)	JS-0508-SM
#2 Lion chain	JL-0800-XX

Consult your local authorized dealer for other Schwank accessories:

- Line-voltage and 24V thermostat and controls
- Side reflector extensions



Inst. Manual - S100



Inst. Manual - P40U



Replacement Parts List



Find a Distributor

USA: 2 Schwank Way, Waynesboro, GA 30830 | Canada: 5285 Bradco Blvd. Mississauga, ON L4W 2A6  
Tel: 1-877-446-3727 | Fax: 1-866-361-0523 | www.schwankgroup.com | csr@schwankgroup.com

