

PRODUCT:

Models  HDS-18 (L/C)  HDS-24 (L/C)  HDS-36 (L/C)  48L/C  HDS-60 (L/C)  HDS-72 (L/C)  
QUANTITY: ITEM:

## Designed Smart

APW Wyott Heavy Duty Cookline Stands are made of stainless and galvanized steel and are available from 18" to 72" sizes, designed to hold individual or multiple units of Heavy Duty Cookline.

Stainless steel top shelf is designed with a 1 3/4" lip to prevent equipment from sliding off back, front and sides.

Equipment stands are designed to raise the Heavy Duty Cookline to the most convenient cooking heights.

One inch "bullet feet" are adjustable and convertible to optional casters.

All tables shipped "knocked down" and are easily assembled.

## APW Wyott Design Features

- 304 Series stainless steel top shelf
- Heavy Duty galvanized steel legs and bottom shelf
- Bottom shelf is adjustable
- Adjustable legs
- 1 3/4" lip around full perimeter



Model Heavy Duty Cookline Stand

## Built Solid

- Heavy duty 16 gauge 304 series stainless steel top
- Heavy duty galvanized steel pipe legs for strength and durability (1 5/8" diameter)
- 5" rubber casters have 200 lbs. weight per caster strength (800 lbs per table)

## Options:

- 5" Hard rubber caster kits (#22800)

## Reliability backed by APW Wyott's Warranty

All APW Wyott Heavy Duty Cookline Equipment is backed by a 1-year limited warranty and a 1-year on-site labor warrant. \*

- Certified by the following agencies:



\*Warranty does not include rock grates, cooking grates, burners shields or fireboxes.

See reverse side for product specifications.

PRODUCT:

QUANTITY:

ITEM:

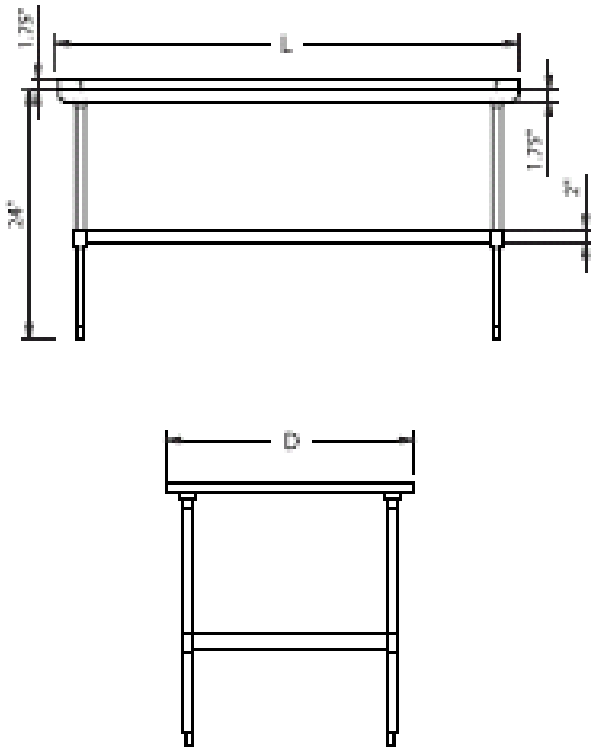

## PRODUCT SPECIFICATIONS

### Construction:

Stainless steel top shelf, galvanized steel bottom shelf, galvanized steel legs.

### Overall Dimensions:

Model	L	D	H	Weight
HDS-24C	24	30	29	50
HDS-24L	24	30	24	48
HDS-30C	30	30	29	57
HDS-30L	30	30	24	50
HDS-36C	36	30	29	59
HDS-36L	36	30	24	57
HDS-48C	48	30	29	71
HDS-48L	48	30	24	69
HDS-60C	60	30	29	80
HDS-60L	60	30	24	78
HDS-72C	72	30	29	89
HDS-72L	72	30	24	87

### Consultant Specifications

Equipment stands are constructed of stainless steel and galvanized steel. Stainless steel top shelf will have 1 3/4" lip around all of the perimeter. Galvanized legs should be 1 7/8" radius. Galvanized bottom shelf will be adjustable. Bullet legs will be adjustable. Units are NSF listed.

### Shipping:

Freight Class: 70  
FOB Cheyenne, WY 82007

\*APW Wyott reserves the right to modify specifications or discontinue models without incurring obligation.