

# Indigo™ Series 600 Ice Cube Machine

Model:  ID-0602A  IY-0604A  ID-0603W  IY-0605W  ID-0692N  IY-0694N



Indigo Series i-600  
Ice Machine on B-570 Bin

Designed for operators who know that ice is critical to their business, the Indigo™ Series ice machine's preventative diagnostics continually monitor itself for reliable ice production. Improvements in cleanability and programmability make your ice machine easy to own and less expensive to operate.

- **Space-Saving Design** – Up to 650 lbs. (295 kgs.) daily ice production and only 30" (76.20 cm) wide.
- **Intelligent Diagnostics** – provide 24 hour preventative maintenance and diagnostic feedback for trouble free operation.
- **Acoustical Ice Sensing Probe** – for reliable operation in challenging water conditions.
- **EasyRead Display** – communicates operating status, cleaning reminders, and asset information through a blue illuminated display.
- **Programmable Ice Production** – by On/Off Time, Ice Volume or Bin Level (with accessory bin level control) further improves energy efficiency and savings.
- **Easy to Clean Foodzone** – Hinged front door swings out for easy access. Removable water-trough, distribution tube, curtain, and sensing probes for fast and efficient cleaning. Select components made with AlphaSan® antimicrobial.
- **DuraTech™ Exterior** – provides superior corrosion resistance. Stainless finish with innovative clear-coat resists fingerprints and dirt.
- Available **LuminIce™ Growth Inhibitor** controls the growth of bacteria and yeast within the foodzone.

## Ice Machine Electric

208-230/60/1 standard.  
(230/50/1 also available)

### Minimum circuit ampacity:

Air Cooled: 10.2  
Water Cooled: 9.7  
Remote: 10.7

### Maximum fuse size:

Air Cooled: 15  
Water Cooled: 15  
Remote: 15

## Specifications

### BTU Per Hour:

9,000 (average) 13,900 (peak)

### Refrigerant:

R-404A CFC-free

### Operating Limits:

- Ambient Temperature Range: 35° to 110°F (1.7° to 43.3°C)  
Water Temperature Range: 35° to 90°F (1.7° to 32.2°C)
- Water Pressure Ice Maker  
Water In:  
Min. 20 psi (137.9 kPa)  
Max. 80 psi (551.1 kPa)



## Ice Shape



**Half Dice**  
3/8" x 1 1/8" x 7/8"  
(.95 x 2.86 x 2.22 cm)



**Dice**  
7/8" x 7/8" x 7/8"  
(2.22 x 2.22 x 2.22 cm)





# Indigo™ Series 600 Ice Cube Machine

## i-600 on B-570 Storage Bin

- (A) Electrical Entrance (2) Options
- (B) 3/8" (0.95 cm) F.P.T. Water Condenser Inlet (water-cooled units)
- (C) 1/2" (1.27 cm) F.P.T. Water Condenser Outlet (water-cooled units)
- (D) 1/2" (1.27 cm) Auxillary Base Drain Socket
- (E) 3/8" (0.95 cm) F.P.T. Ice Making Water Inlet
- (F) 1/2" (1.27 cm) F.P.T. Ice Making Water Drain
- (G) 3/4" (1.91 cm) Bin Drain

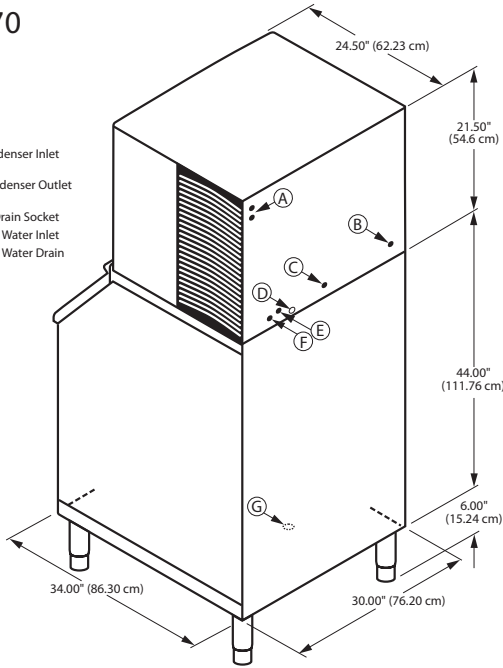

**Installation Note**  
Minimum installation clearance:  
Top/sides: 8" (20.32 cm);  
Back is 5" (12.7 cm)

## Space-Saving Designs



|             | <b>i-600 B-400</b>     | <b>i-600 B-570</b>     |
|-------------|------------------------|------------------------|
| Height      | 59.50"<br>151.13 cm    | 71.50"<br>181.61 cm    |
| Width       | 30.00"<br>76.20 cm     | 30.00"<br>76.20 cm     |
| Depth       | 34.00"<br>86.30 cm     | 34.00"<br>86.30 cm     |
| Bin Storage | 290 lbs.<br>131.7 kgs. | 430 lbs.<br>195.2 kgs. |

Height includes adjustable bin legs 6.00" to 8.00", (15.24 to 20.32 cm) set at 6.00" (15.24 cm).

## Specifications

|   | Model    | Ice Shape | Ice Production 24 Hours |                    | Power Usage<br>kWh/100 lbs.<br>@90°Air/70°F<br>1 Ph | Water Usage/100 lbs.<br>45.4 kgs. of Ice<br>Potable Water |
|---|----------|-----------|-------------------------|--------------------|---|---|
|   |          |           | 70°Air/ 50°F Water      | 90°Air/ 70°F Water |   |   |
| <b>AIR-COOLED</b>   | ID-0602A | dice      | 650 lbs.                | 475 lbs.           | 6.28  | 22.0 Gal.   |
|   |          |           | 295 kgs.                | 215 kgs.           |   | 83.3 L  |
|   | IY-0604A | half-dice | 650 lbs.                | 500 lbs.           | 6.14  | 22.0 Gal.   |
|   |          |           | 295 kgs.                | 227 kgs.           |   | 83.3 L  |
| <b>WATER-COOLED</b>   | ID-0603W | dice      | 650 lbs.                | 560 lbs.           | 4.78  | 22.0 Gal.   |
|   |          |           | 295 kgs.                | 254 kgs.           |   | 83.3 L  |
|   | IY-0605W | half-dice | 650 lbs.                | 610 lbs.           | 4.68  | 22.0 Gal.   |
|   |          |           | 295 kgs.                | 277 kgs.           |   | 83.3 L  |
| * Water-cooled Condenser Water Usage / 100 lbs. /45.4 kgs. Of Ice: 157 gal./ 594 L. |          |           |                         |                    |   |   |
| * Water-cooled models are excluded from ENERGY STAR qualification.                  |          |           |                         |                    |   |   |
| <b>REMOTE-COOLED</b>  | ID-0692N | dice      | 630 lbs.                | 520 lbs.           | 6.36  | 22.0 Gal.   |
|   |          |           | 286 kgs.                | 236 kgs.           |   | 83.3 L  |
|   | IY-0694N | half-dice | 630 lbs.                | 545 lbs.           | 6.28  | 22.0 Gal.   |
|   |          |           | 286 kgs.                | 247 kgs.           |   | 83.3 L  |

Order ice storage bin separately. Ice storage bin and JC-0895 remote condenser must be ordered separately. Consult remote condenser specification sheet for details. To order 3 phase add "3" suffix to model # (ID-0602A3).

## Accessories

**LuminIce™ Growth Inhibitor**  
reduces yeast and bacteria growth for a cleaner ice machine.



**Bin Level Control**  
Allows ice bin level to be automatically set. Built-in LED light illuminates bin.



**Arctic Pure® Water Filters**  
Reduces sediment and chlorine odors for better tasting ice.



**AuCS®**  
schedules and performs routine ice machine cleaning automatically.

