



PRO-MAX[®] SMOOTH TWO-SIDED GRILLS WITH PRO-LIFT[™] HINGE

Models GR10B, GR10IB, GR14B, GR14BI & GR28IB

Features/Benefits:

- ★ Expand your menu with Star's Pro-Max two sided grills. Prepare burritos, quesadillas, sandwiches, chicken breasts, hamburgers, steaks, vegetables and many other menu items quickly and easily while maximizing space.
- ★ Heavy-duty 10", 14" and 28" heavy-duty smooth cast iron or aluminum platens provide long life and superior performance.
- ★ The Star Pro-Lift hinge system provides for unmatched reliability with safe and effortless operation. The top platens lift parallel to the bottom platen for a full three (3) inches before rotating up so that thin tortillas or tall sandwiches and burritos cook evenly.
- ★ The bottom platen has a patented splash guard to help keep products and grease in their place.
- ★ Heavy gauge, water resistant flexible plastic conduit protects electrical connections.
- ★ Thermostat is rated from 175°F (79°C) to 550°F (302°C) and provides accurate sensing of temperature.
- ★ Ergonomically designed control panel provides easy access to controls and grease drawer.
- ★ Removable, large capacity grease drawer in the front of unit for easy clean up.

Application:

Star's Two-Sided Grills can prepare chicken breasts, hamburgers, quesadillas, sandwiches and many other products in half the time of standard griddles. The heavy-duty platens retain energy and deliver faster performance. Grills are compact and portable providing flexibility in your operations.

Quality Construction:

The rugged body is constructed of 18 gauge stainless steel. The Pro-Lift[™] Hinge System is constructed from hardened aluminum for strength and durability. The cord is resistant to water and oil with metallic braiding to protect wiring. Furnished with a 6' cord and standard NEMA plug.

Warranty:

Star's Two-Sided Grills are covered by a one year parts and labor warranty.

Patent No. 6,257,126



Model GR10IB



Model GR14IB



Kitchen Innovations 2011 Award presented by the National Restaurant Association, Hotel-Motel Show





Star Manufacturing International, Inc.

Pro-Max® Smooth Two-Sided Grills

PRO-MAX® SMOOTH TWO-SIDED GRILLS WITH PRO-LIFT™ HINGE

Models GR10B, GR10IB, GR14B, GR14IB & GR28IB

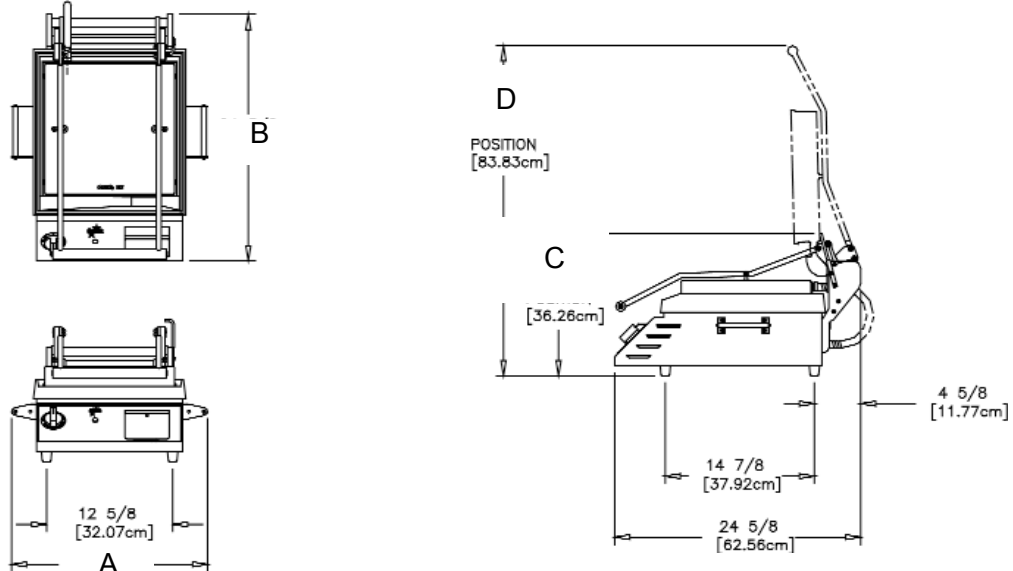

Model and Specifications

Model No.	Grid Surface	(A) Width Inches (cm)	(B) Depth Inches (cm)	Height		Voltage	Wattage	Amps	NEMA	Approximate Weight	
				(C) Closed Inches (cm)	(D) Open Inches (cm)					Shipping lbs. (kg)	Installed lbs. (kg)
GR10B	Alum.	16-1/8" (40.9)	21-1/8" (53.7)	14-1/4" (36.2)	28-3/4" (73)	120	1800	15	5-15P	52 lbs.	36 lbs.
						120	1800	15	5-20P*		
						208/240	1350/1800	6.5/7.5	6-15P	(23.6)	(16.3)
GR10IB	Iron	16-1/8" (40.9)	21-1/8" (53.7)	14-1/4" (36.2)	28-3/4" (73)	120	1800	15	5-15P	67 lbs.	57 lbs.
						120	1800	15	5-20P*		
						208/240	1350/1800	6.5/7.5	6-15P	(30.4)	(28.1)
GR14B	Alum.	19-5/8" (49.8)	24-5/8" (62.5)	14-1/4" (36.2)	33" (83.2)	120	1800	15	5-15P	67 lbs.	55 lbs.
						120	1800	15	5-20P*		
						208/240	1350/1800	6.5/7.5	6-15P	(30.4)	(24.9)
GR14IB	Iron	19-5/8" (49.8)	24-5/8" (62.5)	17-1/4" (43.8)	36" (91.4)	208/240	2700/3600	13/15	6-20P	101 lbs.	87 lbs.
										(45.9)	(39.4)
GR28IB	Iron	34-1/4" (87)	24-5/8" (62.5)	17-1/4" (43.8)	36" (91.4)	208/240	5400/7200	26/30	L6-30P	206 lbs.	171 lbs.
						208/240	5400/7200	26/30	6-50P*	(93.4)	(77.5)

*Canadian Requirements

NOTE: Units weighing more than 80 pounds have standard 4" legs.

Typical Specifications

Two-Sided Grills are constructed with an 18 gauge stainless steel body. Cast iron or aluminum smooth platens are provided as standard. The Pro-Lift™ Hinge System provides easy operation of the top platen. Grilling height between platens is up to 3" with the Pro-Lift™ Hinge System providing 3-4 pounds of pressure to the cooking product placed on bottom platen. Metal sheathed tubular elements are standard. Adjustable non-skid feet are standard. Six foot power cord with Nema rated plug (see specifications above). Units are UL, UL Sanitation or UL Canada Standards approved. Printed in the U. S. A.

Due to periodic changes in designs, methods, procedures, policies and regulations, the specifications contained in this sheet are subject to change without notice. While Star Manufacturing exercises good faith efforts to provide information that is accurate, we are not responsible for errors or omissions in information provided or conclusions reached as a result of using the specifications. By using the information provided, the user assumes all risks in connection with such use.

Star Manufacturing International Inc. - 10 Sunnen Drive - P.O. Box 430129 - St. Louis, MO 63143-3800

Phone: (800) 264-7827 - FAX: (800) 264-6666 - www.star-mfg.com