



# GX Series Broiler with Nonadjustable Grates

Item: \_\_\_\_\_  
 Quantity: \_\_\_\_\_  
 Project: \_\_\_\_\_  
 Approval: \_\_\_\_\_  
 Date: \_\_\_\_\_

Models:

- GXRN24       GXRN30       GXRN36       GXRN48       GXRN60



Model GXRN24

### Standard Features:

- Heavy-duty, reversible, cast iron grates in 3" (76mm) sections
- Built-in front grease trough
- Large capacity, 1-1/2" (38mm) deep drip pan
- Aluminized steel burners, one every 6" (152mm)
- Cast iron radiants, one every 6" (152mm)
- 15,000 BTU/hr per burner
- Individual burner controls
- Standing pilot for instant lighting
- 3/4" Gas regulator

- 4" (102mm) Legs with adjustable feet
- Exterior finish - stainless steel front and sides

### Optional Features:

- Stainless steel stand with intermediate shelf
- 3" (76mm) deep water pan in lieu of 1-1/2" (38mm) deep drip pan, for models GXRN30, 36, 48, and 60; no additional charge
- Casters on stand - swivel type
- Stainless steel splatterguards (with original equipment order)

### Specification:

Shall be U.S. Garland GX series Broiler w/nonadjustable grate, Model \_\_\_\_\_ with total BTU/hr rating of \_\_\_\_\_ when used with natural/propane gas. Finish is to be stainless steel front and sides.



Model #	Description	Total BTU	SHIPPING INFORMATION	
			Lb/Kg	Cubic Feet
GXRN24	24" (610mm) Wide Broiler	60,000	226/103	18
GXRN30	30" (762mm) Wide Broiler	75,000	266/121	22
GXRN36	36" (914mm) Wide Broiler	90,000	300/136	25
GXRN48	48" (1219mm) Wide Broiler	120,000	387/176	33
GXRN60	60" (1524mm) Wide Broiler	150,000	467/212	40

GX Series Broiler with Nonadjustable Grates

Garland Commercial Industries, LLC  
 185 East South Street  
 Freeland, PA 18224  
 Phone: (570) 636-1000  
 Fax: (570) 636-3903

Garland Commercial Ranges Ltd  
 1177 Kamato Road,  
 Mississauga, Ontario  
 L4W 1X4 CANADA  
 Phone: 905-624-0260  
 Fax: 905-624-5669



Model #	Dimensions: In. (mm)			No. of Burners	Total BTU*	Gas Broiling Grid: In. (mm)	
	Width	Depth	Height			Width	Depth
GXRN24	24(610)	27(656)	13(330)	4	60,000	20(508)	21-1/2(546)
GXRN30	30(762)	27(646)	13(330)	5	75,000	26(660)	21-1/2(546)
GXRN36	36(914)	27(646)	13(330)	6	90,000	32(813)	21-1/2(546)
GXRN48	48(1219)	27(646)	13(330)	8	120,000	44(1118)	21-1/2(546)
GXRN60	60(1524)	27(646)	13(330)	10	150,000	56(1422)	21-1/2(546)

\* Natural and Propane Gas Gas Manifold 3/4" NPT on all models

Many local codes exist and it is the responsibility of the owner and installer to comply with those codes.

Garland/U.S. Range products are not approved or authorized for home or residential use, but are intended for commercial applications only. Garland / U.S. Range will not provide service, warranty, maintenance or support of any kind other than in commercial applications.

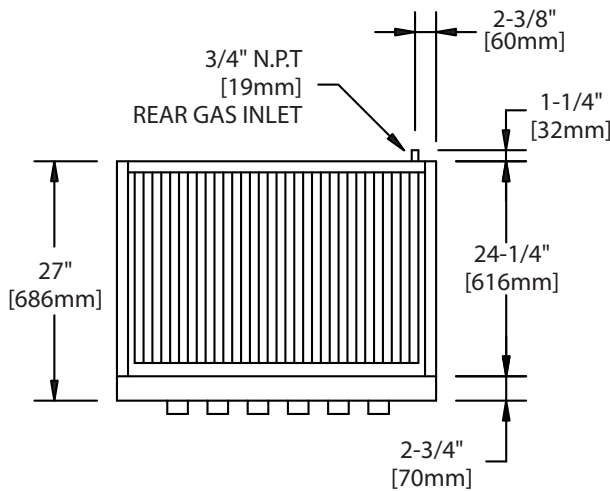

Manifold Operating Pressure All Models			
Natural Gas		Propane	
"WC	Mbar	"WC	Mbar
5	12.5	10	25

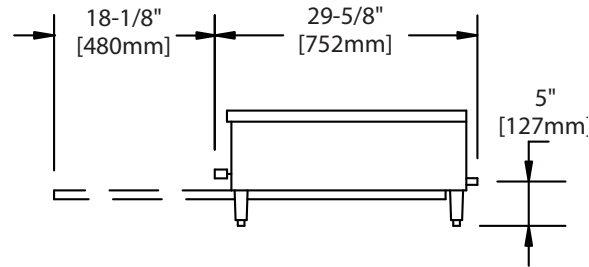
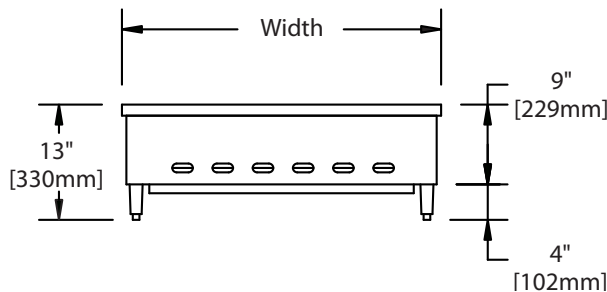

Form# GXRN (02/27/09)