



HOT PLATE

GAS BURNERS

HOT PLATE GAS BURNERS

“Anvil’s Hot Plate gas burners, provide a simple and effective way to prepare a variety of foods, sauces and stews in an economical, safe and hassle free way.”

APPLICATION

- IDEAL FOR USE IN STEAK HOUSES, RESTAURANTS, COFFEE SHOPS, CLUBS AND PUBS
- AVAILABLE IN VARIOUS SIZES

CONSTRUCTION

- STAINLESS AND ALUMINIZED CONSTRUCTION
- HEAVY DUTY PAINTED CAST IRON GRATES
- FULL WIDTH STAINLESS STEEL DRIP PAN
- HEAVY DUTY BRASS VALVES
- 3/4 NPT GAS INLET



Anvil reserves the right, without notice, to make changes and revisions to product specifications, materials and design, which in our opinion, will provide better performance, durability and efficiency.



ALL ANVIL EQUIPMENT COMES WITH A ONE YEAR WARRANTY ON COMPONENTS AND DEFECTIVE WORKMANSHIP



ANVIL



NOTE:

When viewing the appliance from the front in its usual operating position, the width (W) of the product is the total distance from left to right ; the depth (D) of the product is the total distance from front to back ; the height (H) is the total distance from the bottom of the product to the top

HOT PLATE GAS BURNERS

MODELS:
HPA1002
HPH1004
HPA1006

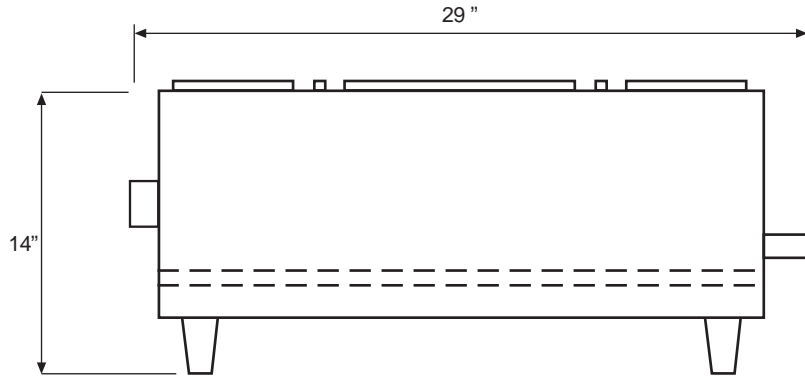
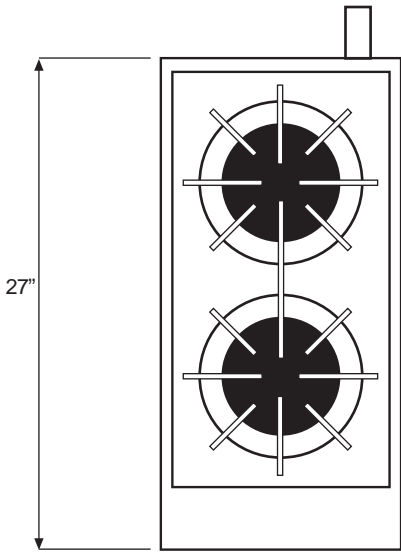

DESCRIPTION	2 BURNERS	4 BURNERS	6 BURNERS
MODELS	HPA1002	HPA1004	HPA1006
GAS	NATURAL / LP	NATURAL / LP	NATURAL / LP
OUTPUT: BTU	52000	104000	156000
DIMENSIONS (inch) (W x D x H)	12 x 27 x 14	24 x 27 x 14	36 x 30 x 16
BOX DIMNS (inch) (W x D x H)	14 x 30 x 16	26 x 30 x 16	38 x 30 x 16
PACKED WEIGHT (lbs)	98	169	230
COMPLIES WITH SPEC	-	-	-

Note: Output performance figures quoted are dependant on various factors.



Website: www.anvilworld.com

CGC_ANVIL_USA_01