



WIDE BASKET DOLLY

PURPOSE

The Wide Basket Dolly cart system is recommended to be used in central commissaries, satellite, and finishing kitchens to direct-serving counters. The dolly cart is designed to fit most narrow roll-in freezers and refrigerators. See dimensions for allowances.

EASY-TO-USE

The adjustable shelving is designed to allow operator maximum capacity, deep shelving, and plans for different narrow configurations. It is built on 5-inch casters for easy mobility and includes two locking casters. It is basin designed to catch excess moisture, has a double-sided locking gate to secure pans during transport, and includes a plug for easy draining.

DURABLE

Built to last with quality craftsmanship, high grade corrosive-resistant stainless steel, and rugged construction. It is easy to clean.

WARRANTY

One-year limited warranty covering materials and labor.



**WIDE BASKET DOLLY
FOR USE WITH CVAP®
CAT529-BD/BDR**

The Wide Basket Dolly is designed to hold steam table pans and meal baskets.



WINSTON INDUSTRIES, LLC.
2345 Carton Drive | Louisville, KY 40299 USA | www.winstonindustries.com
Phone: 1.800.234.5286 | 1.502.495.5400 | Fax: 1.502.495.5458
Specifications subject to change without notice.

JOB

ITEM#



**WIDE BASKET DOLLY
FOR USE WITH CVAP® CAT529-BD/BDR**

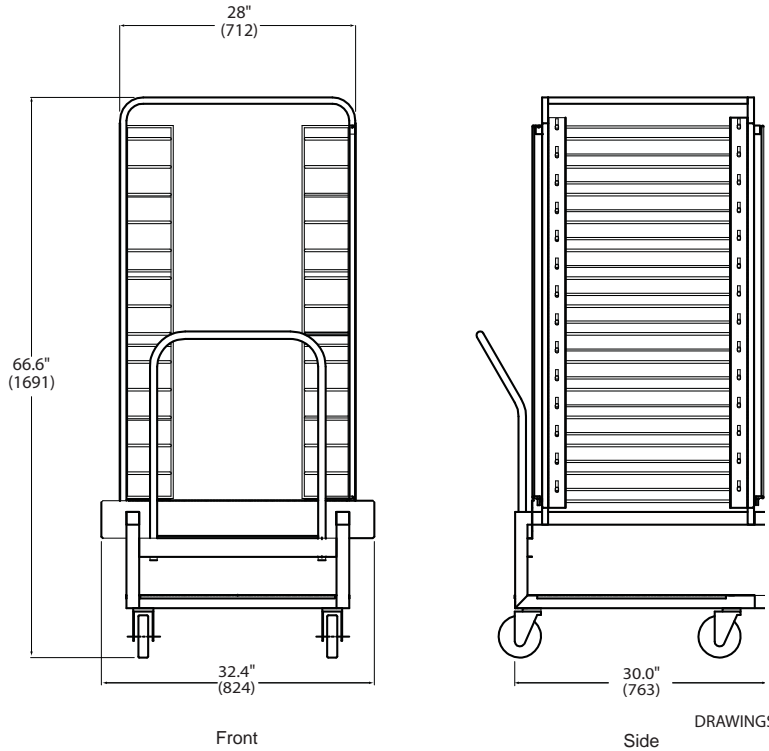

DRAWINGS NOT TO SCALE

capacity	size in (mm)	ship weight	ship cube
AW= 28	H= 65.6" (1691)	US / CANADA	
AN= 14*	W= 32.4" (824)	Call factory	Call factory
AD= 14	D= 30.0" (763)	INTERNATIONAL	
STP= 14		NOT AVAILABLE FOR INTERNATIONAL	
SP= 14			

*Must be placed on sheet pan • AW= Wide Speedline Wire Baskets (13.4" x 20.8" x 2.6") • AN= Narrow Speedline Wire Baskets (13.4" x 20.8" x 2.6")
AD= Narrow and Deep Speedline Wire Baskets (13.4" x 20.8" x 4.5") • Steam Table Pan (12" x 20" x 2.5") • SP= Sheet Pan (18" x 26")

SHORT FORM SPECS

Shall be Winston Wide Basket Dolly, for use with CVap Thermalizer cabinet model(s) CAT529-BD/BDR, for transporting precooked food items for reheating, holding, or refrigerating.

CONSTRUCTION

MATERIALS: To be commercial and institutional grade, heavy duty stainless steel interior and exterior to provide ease of cleaning and long service life with reasonable use and care. Built to last with quality craftsmanship and rugged construction.

RACKING OF FOOD: Adjustable shelving to receive 28 wide speedline wire baskets, 14 narrow speedline wire baskets, 14 narrow and deep speedline wire baskets, 14 steam table pans, and 14 sheet pans.

CASTERS: Includes two 5" locking, two 5" non-locking, heavy duty, non-marking.

WARRANTY

Limited 1 year warranty (excluding gaskets, lamps, hoses, power cords, glass panels, and evaporators). Warranty disclaimer for failure to clean. Ask for complete warranty disclosure.

SPECIFY THE FOLLOWING WHEN ORDERING:

STANDARD (NO ADDITIONAL COST):

1. Caster preference: 5" (127 mm) casters

OPTIONAL (ADDITIONAL COST):

1. Extended Warranty: Adds parts and labor warranty coverage for one additional year.
2. Added accessories and supplies.

ACCESSORIES & SUPPLIES (ADDITIONAL COST)

PS3053/4	Citranox all-purpose cleaner & scale remover 4 qt.
PS3053/12	Citranox all-purpose cleaner & scale remover 12 qt.

**BUY WINSTON SERVICE PARTS, ACCESSORIES,
AND SUPPLIES ONLINE!
FACTORY DIRECT AT WWW.WINSTONINDUSTRIES.COM**

