

Fusion™ Conveyor Toaster

Models:

- 2030 2032
 2040 2041 2042



CONTROL
PANEL



Standard Features:

- Dome-shaped reflector bounces heat and energy where it is most needed.
- Energy-saving "Sleep" mode.
- Innovative air curtain prevents heat loss.
- Cool-Skin front and rear panels stay cool to the touch during operation.
- Faster toasted foods thanks to better convection and focused heat.
- Well suited to a variety of products - sandwiches, chicken nuggets, par-baked pizza, pretzels, tortillas and a variety of appetizers.

Available Colors:

- Black
- Navy Blue
- Red
- Hunter Green
- Gold
- Stainless

Specifications:

General: The Fusion™ infrared conveyor toaster is self-contained, and conveyORIZED. It is designed for countertop use and must be used with the appropriate 4" (10 cm) legs for proper cooling. Intensity is adjustable from top to bottom. Conveyor speed is adjustable from 15 seconds to 5 minutes cooking time. Removable crumb-trays for ease of cleaning.

Controls: The controls are located on the front of the unit. It includes a power on-off switch, intensity control, digital display, conveyor speed control, four programmable buttons/pre-sets with a "manual" cook setting mode, conveyor direction control, and sleep mode switch.

Construction: Exterior is fabricated from No. 4 finish stainless steel. The conveyor belt is a flexible stainless steel design with capacity for 10.5" (27 cm) or 15.5" (39 cm) wide product and a travel distance of 34" (86 cm) or 40" (102 cm), of which 21" (53 cm) or 25" (64 cm) is in the baking chamber. A DC, brushless motor powers the chain drive conveyor.



2030 Models:

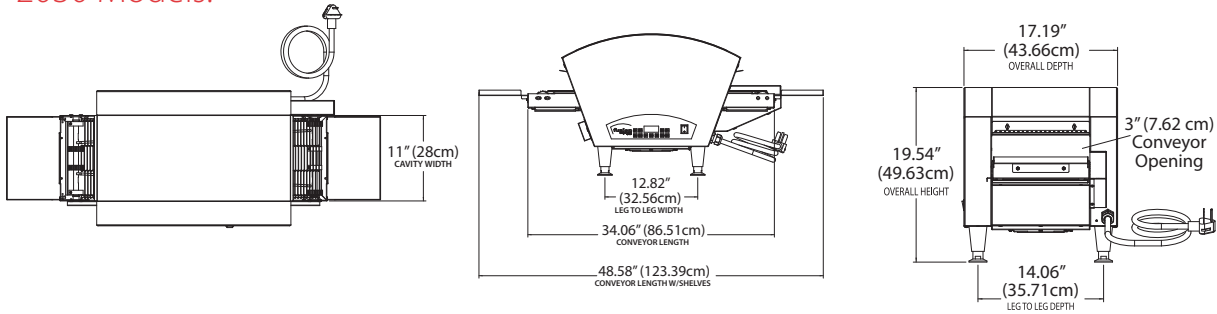

2040 Models:

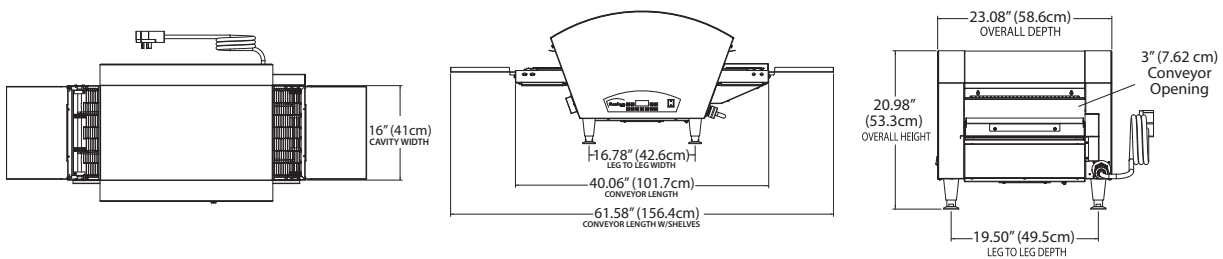

Electrical Service: Heat is supplied by nine (9) or twelve (12) infrared heating elements on top and nine (9) or twelve (12) infrared heating elements on the bottom of the unit. Each toaster is rated at 4.7 kW or 8.3kW. A separate circuit breaker is required for each toaster with the proper voltage, amperage, phase and hertz as indicated by model number. SINGLE PHASE UNIT REQUIRES 50 AMP SERVICE with plug type NEMA-50P. THREE PHASE UNITS REQUIRES 30 AMP SERVICE with plug type NEMA-30P.

Ventilation: Ventilation is not required but local codes prevail. These are the "authority having jurisdiction" as stated by the National Fire Protection Association, Inc. in NFPA 96-1994.

Spacing: The toaster must have 6" (152mm) of clearance from combustible surfaces and 24" (610mm) clearance on both sides from other cooking equipment.

Warranty: All new Infrared Conveyor Toasters come with a one year parts/labor warranty. Defective parts of the original equipment on all installed toasters are warranted for one year from the date of purchase.

Model No.	Height	Cavity Width	Input Rate	Volts	Amps	Phase	Hz	Weight
DOMESTIC MODEL								
2030	19.54" (49.6cm)	11" (28cm)	8.3kW	208/240	40	1	50/60	120 lbs. (54.3kg)
2040	21" (53cm)	16" (41cm)	8.3kW	208/240	40	1	50/60	130 lbs. (58.9kg)
2041	21" (53cm)	16" (40cm)	8.3kW	208/240	24	3	50/60	130 lbs. (58.9kg)
INTERNATIONAL MODEL								
2032	19.54 (49.6cm)	11" (28cm)	4.7kW	220/380 230/400 240/415	11.5	3	50/60	120 lbs. (54.3kg)
2042	21" (53cm)	16" (41cm)	8.3kW	220/380 230/400 240/415	20	3	50/60	130 lbs. (58.9kg)

NOTE: Specifications subject to change without notice.