

DELI / BAKERY CASES

NEWLY IMPROVED EUROPEAN STYLE



TD-4R / TD-5R

≡ FEATURES & BENEFITS ≡

■ ENVIRONMENTALLY FRIENDLY, EFFICIENT REFRIGERATION SYSTEM

Turbo Air's refrigerators are designed with oversized and balanced environmentally friendly R-134A (CFC Free) refrigeration. These include large evaporators and condensers for faster cooling and balanced temperature throughout the cabinet.

■ FRAMELESS GLASS AND ELEGANT EURO DESIGN

The frameless all sided glass display cases provide full product visibility to optimize display effects and increase impulse sales. Its elegant contemporary euro design will not only enhance any store atmosphere but also will keep product presentation at its best and beautiful.

■ CERTIFIED AND LISTED UNDER NSF/ANSI-7

■ CURVED TEMPERED FRONT GLASS

■ SLOPED REAR DOORS FOR PRODUCT ACCESS

■ INDEPENDENTLY WIRES SHELF LIGHTS

■ CANTILEVERED WIRED SHELVES ADJUSTABLE UP AND DOWN, TILTED

■ 304 STAINLESS STEEL FLOOR AND AIR FLOW GRILLE

■ TD-4, 5 NON REFRIGERATED MODELS AVAILABLE

■ HIGH-DENSITY POLYURETHANE INSULATION

The entire cabinet structure is foamed-in-place using high density, CFC free polyurethane insulation.

■ FOUR POINT LEVELING SYSTEM

■ EASY ACCESS CONTROL PANEL

■ REFRIGERATED DELI CASE HOLDS AVG. 36°F ~ 38°F FOR FRESHER DELI PRODUCTS

■ REAR ACCESS OF COMPRESSOR COMPARTMENT FOR QUICK AND EASY SERVICE

■ 5" CASTERS STANDARD

■ RECOMMENDED OPERATING CONDITIONS

TD models are designed to operate in environments where temperature & humidity do not exceed 75°F and 55% relative humidity.

Model	CU./FT.	# of Shelves	HP	AMPS	Crated Weight (lbs.)	L x D x H* (inches)
TD-4R	11.7	2	1/2	17.2	588	47 ³ / ₈ x 32 ³ / ₈ x 47 ¹ / ₄
TD-5R	12.7	2	1/2	17.2	697	59 ¹ / ₄ x 32 ³ / ₈ x 47 ¹ / ₄

* Height does not include 5-1/4" caster height.

TD MODELS SPECIFICATIONS

ELECTRICAL DATA	TD-4R	TD-5R
Voltage	115/60/1	115/60/1
Plug Type	Ⓢ NEMA-5-20P	Ⓢ NEMA-5-20P
Full Load Amperes	17.2	17.2
Compressor HP	1/2	1/2
Refrigerant	R-134A	R-134A
Cord Length (ft.)	9	9
DIMENSIONAL DATA		
Net Capacity cu. ft.	11.7	12.7
Ext. Length Overall in.	47 ³ / ₈ (1204mm)	59 ¹ / ₄ (1505mm)
Ext. Depth Overall in.	32 ³ / ₈ (823mm)	32 ³ / ₈ (823mm)
Ext. Height Overall in.*	47 ¹ / ₄ (1200mm)	47 ¹ / ₄ (1200mm)
Int. Length Overall in.	44 ¹ / ₈ (1123mm)	45 ⁷ / ₈ (1163mm)
Int. Depth Overall in.	22 ¹ / ₄ (565mm)	22 ¹ / ₄ (565mm)
Int. Height Overall in.	26 ¹ / ₈ (665mm)	26 ¹ / ₈ (665mm)
Crated Weight lbs.	588	697
# of Shelves	2	2
Self Size	(Top) 42 x 14 ¹ / ₂ (Bottom) 42 x 19	(Top) 54 x 14 ¹ / ₂ (Bottom) 54 x 19

Design and specifications subject to change without notice.
Actual shipping weight may differ due to extra packing materials for product protection.
* Height does not include 5-1/4" caster height.

- **WARRANTY : 1 Year Parts and Labor Warranty
Additional 4 Year Warranty on Compressor**
- **SELF-CONTAINED SYSTEM, NO PLUMBING REQUIRED**
- **SIMPLE PLUG-IN INSTALLATION**

(unit : inch)

PLAN VIEW

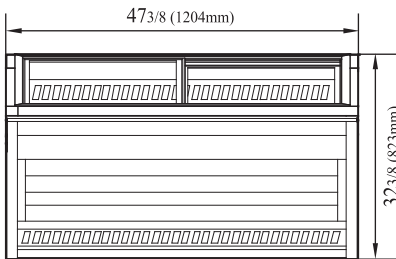

TD-4R
TOP VIEW

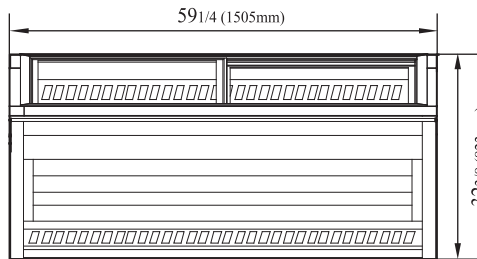

TD-5R
TOP VIEW

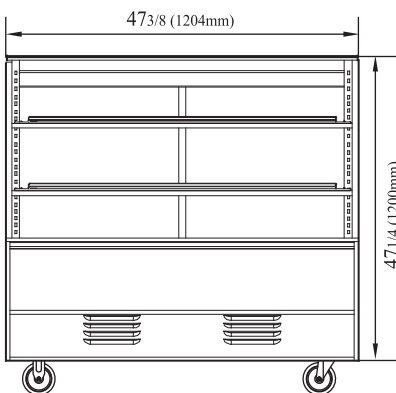

TD-4R
FRONT VIEW

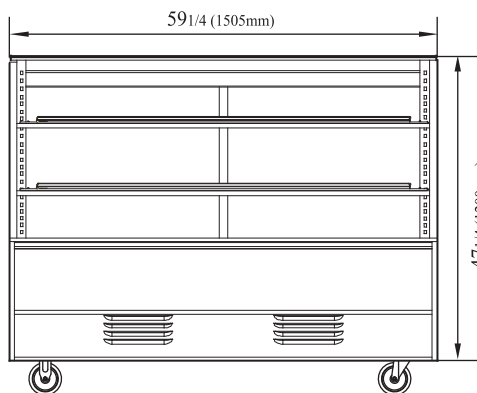

TD-5R
FRONT VIEW

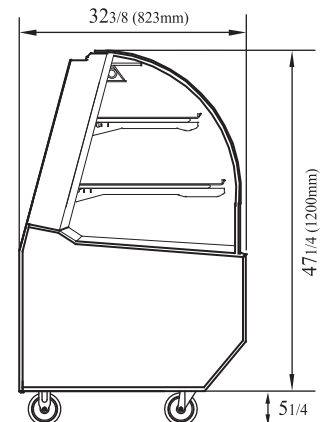

SIDE VIEW