



**TRUE FOOD SERVICE EQUIPMENT, INC.**

St. Charles Industrial Center • P.O. Box 970 • O'Fallon, Missouri 63366  
 (636)240-2400 • FAX (636)272-2408 • (800)325-6152 • www.truemfg.com  
 Parts Dept. (800)424-TRUE • Parts Dept. FAX# (636)272-9471

Project Name: \_\_\_\_\_

A/A #

Location: \_\_\_\_\_

Item #: \_\_\_\_\_ Qty: \_\_\_\_\_

SIS #

Model #: \_\_\_\_\_

Model:  
**TWT-60F**

**Worktop:**  
*Solid Door Freezer*



**TWT-60F**

- ▶ True's worktop units are designed with enduring quality that protects your long term investment.
- ▶ Designed using the highest quality materials and components to provide the user with colder product temperatures, lower utility costs, exceptional food safety and the best value in today's food service marketplace.
- ▶ Oversized, environmentally friendly (R404A) forced-air refrigeration system holds -10°F (-23.3°C). Ideal for both frozen foods and ice cream.
- ▶ All stainless steel front, top and cabinet ends. Matching aluminum finished back. Cabinet top and backsplash is one piece formed construction. Bacteria and food particles can not be trapped underneath as with other two-piece worktop units.
- ▶ Front breathing.
- ▶ Foamed-in-place, high density polyurethane insulation (CFC free).
- ▶ Heavy duty PVC coated wire shelves.

**ROUGH-IN DATA**

Specifications subject to change without notice.  
 Chart dimensions rounded up to the nearest 1/8" (millimeters rounded up to next whole number).

Model	Solid Doors	Capacity (Cu. Ft.) (liters)	# of Shelves	Cabinet Dimensions (inches) (mm)			HP	Voltage	Amps	NEMA Config.	Cord Length (total ft.) (total m)	Crated Weight (lbs.) (kg)
				L	D†	H*						
TWT-60F	2	15.5 439	4	60 <sup>3</sup> / <sub>8</sub> 1534	30 <sup>1</sup> / <sub>8</sub> 766	33 <sup>3</sup> / <sub>8</sub> 848	1/2 1/2	115/60/1 230-240/50/1	10.9 6.2	5-15P ▲	7 2.13	355 162

† Depth does not include 1" (26 mm) for rear bumpers.

▲ Plug type varies by country.

\* Height does not include 6 1/4" (159 mm) for castors or 6" (153 mm) for optional legs.



**APPROVALS:**

Model:  
**TWT-60F**

**Worktop:**  
Solid Door Freezer



## STANDARD FEATURES

### DESIGN

- True's commitment to using the highest quality materials and oversized refrigeration systems provides the user with colder product temperatures, lower utility costs, exceptional food safety and the best value in today's food service marketplace.

### REFRIGERATION SYSTEM

- Factory engineered, self-contained, capillary tube system using environmentally friendly (CFC free) R404A refrigerant.
- Oversized, factory balanced refrigeration system with guided airflow to provide uniform product temperature.
- Extra large evaporator coil balanced with higher horsepower compressor and large condenser; maintains -10°F (-23.3°C). Ideal for both frozen foods and ice cream.
- Sealed, cast iron, self-lubricating evaporator fan motors and larger fan blades give True worktop units a more efficient low velocity, high volume airflow design. This unique design insures faster temperature recovery and shorter run times in the busiest of food service environments.
- Condensing unit access in back of cabinet, slides out for easy maintenance.
- Automatic defrost system time-initiated, time-terminated.

### CABINET CONSTRUCTION

- Exterior - stainless steel front, top and ends. Matching aluminum finished back. Top and backsplash is one piece formed construction.
- Interior - attractive, NSF approved, white aluminum liner. 300 series stainless floor with coved corners.
- Insulation - entire cabinet structure and solid doors are foamed-in-place using high density, CFC free, polyurethane insulation.
- 5" (127 mm) diameter stem castors - locks provided on front set. 36" (915 mm) work surface height.

### DOORS

- Stainless steel exterior with white aluminum liner to match cabinet interior.
- Positive seal self-closing doors with 90° stay open feature. Doors swing within cabinet dimensions.
- Each door fitted with 12" (305 mm) long recessed handle that is foamed-in-place with a sheet metal interlock to insure permanent attachment.
- Magnetic door gaskets of one piece construction, removable without tools for ease of cleaning.

### SHELVING

- Four (4) adjustable, heavy duty PVC coated wire shelves 27<sup>1</sup>/<sub>2</sub>" L x 16" D (699 mm x 407 mm). Four (4) chrome plated shelf clips included per shelf.
- Shelf support pilasters made of same material as cabinet interior; shelves are adjustable on 1/2" (13 mm) increments.

### MODEL FEATURES

- Evaporator is epoxy coated to eliminate the potential of corrosion.
- NSF-7 compliant for open food product.

### ELECTRICAL

- Unit completely pre-wired at factory and ready for final connection to a 115/60/1 phase - 15 amp dedicated outlet. Cord and plug set included.



115/60/1  
NEMA-5-15R

### OPTIONAL FEATURES/ACCESSORIES

Upcharge and lead times may apply.

- 230 - 240V / 50 Hz.
- 6" (153 mm) standard legs.
- 6" (153 mm) seismic/flanged legs.
- Basic overshef.
- Sandwich/salad service shelf.
- Single utility shelf.
- Double utility shelf.
- 28<sup>1</sup>/<sub>4</sub>" (718 mm) deep, 1/2" (13 mm) thick, white polyethylene cutting board. Requires "L" brackets.
- 28<sup>1</sup>/<sub>4</sub>" (718 mm) deep, 1/2" (13 mm) thick, composite cutting board. Requires "L" brackets.
- Additional shelves.
- Heavy duty, 16 gauge tops.
- ADA compliant models with 34" (864 mm) work surface height.
- Remote cabinets (condensing unit supplied by others), consult factory technical service department for BTU information.

## PLAN VIEW

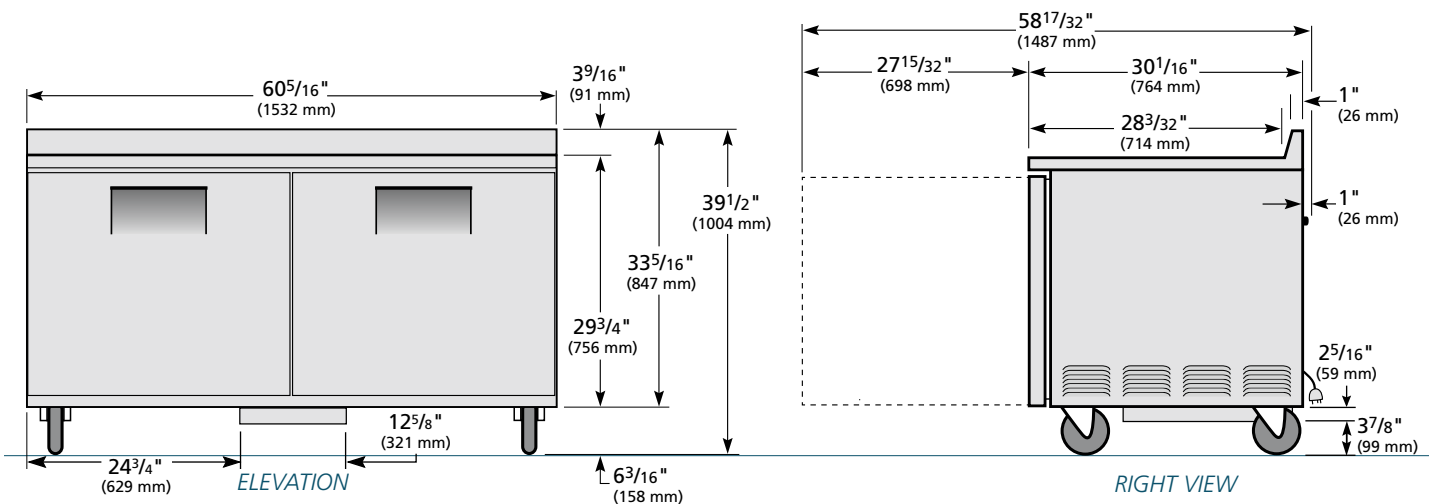

### WARRANTY

One year warranty on all parts & labor and an additional 4 year warranty on compressor. (U.S.A. only)

METRIC DIMENSIONS ROUNDED UP TO THE NEAREST WHOLE MILLIMETER

SPECIFICATIONS SUBJECT TO CHANGE WITHOUT NOTICE



Model	Elevation	Right	Plan	3D
TWT-60F	TFPY03E	TFPY03S	TFPY03P	TFPY033

## TRUE FOOD SERVICE EQUIPMENT

St. Charles Industrial Center • P.O. Box 970 • O'Fallon, Missouri 63366 • (636)240-2400 • FAX (636)272-2408 • (800)325-6152 • www.truemfg.com